

WINGET

Tracked Power Dumpers



TD500 HL & TD650



conservatory building
landscaping
pond building
kerbing
house clearance
groundcare
market gardening
golf course maintenance
swimming pool building
fence erection
stables
farming
forestry
house extensions
refurbishing
flagging
park maintenance
plant & tool hire
viticulture
groundwork
gardening
...

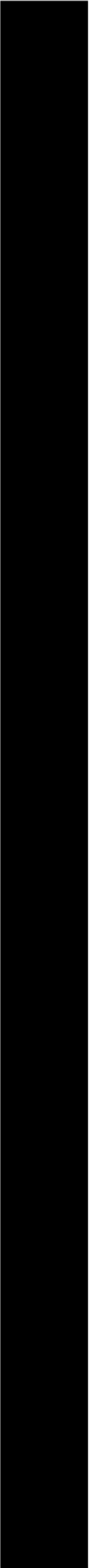

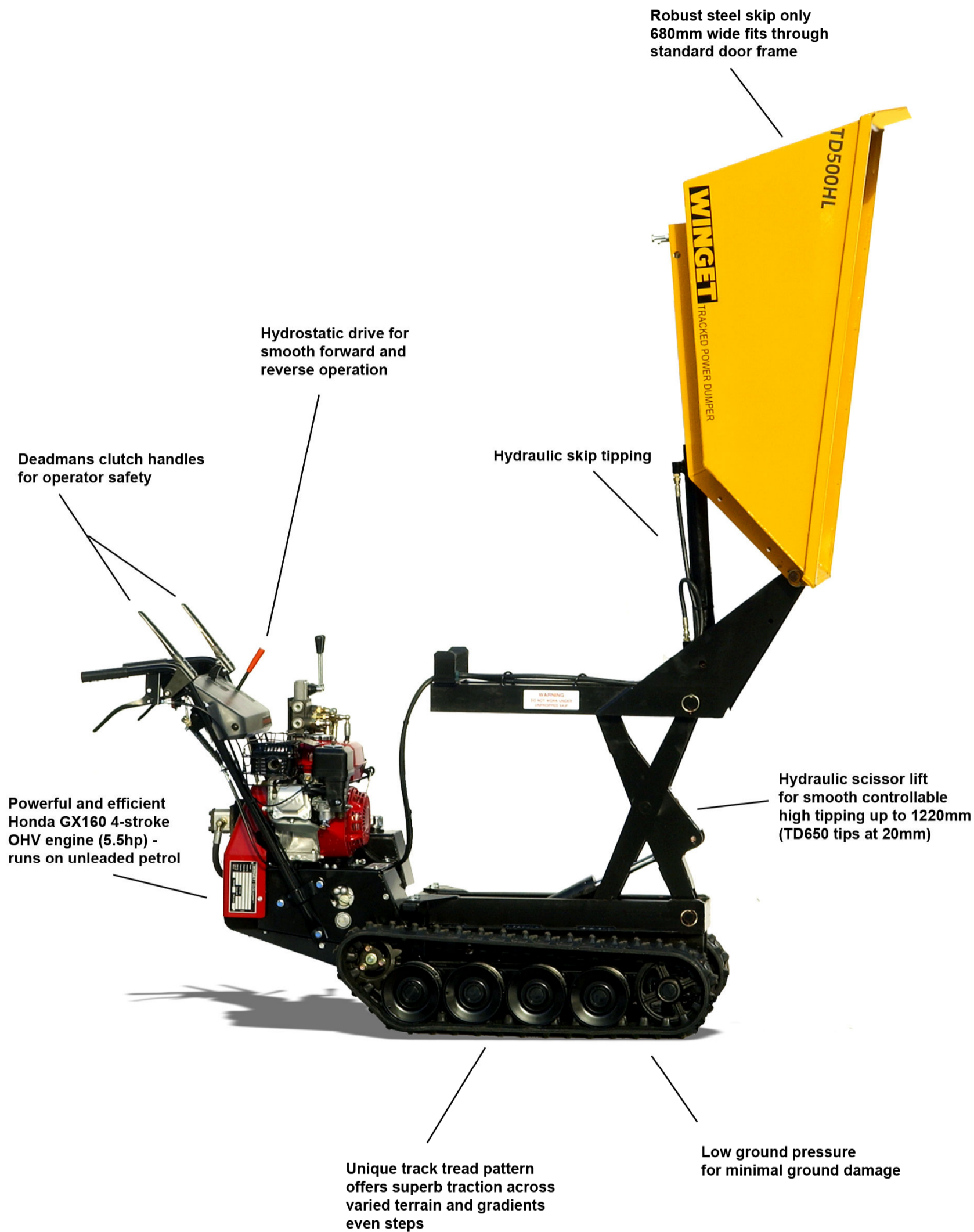

High tip over the side of skips or standard tip

Narrow access - only 680 mm wide

Hydrostatic Drive - smooth forward / reverse up to 4 km/h

Rubber Tracks - superb traction and low ground pressure

Safe to operate - deadmans handles

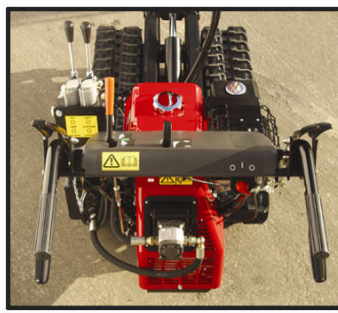
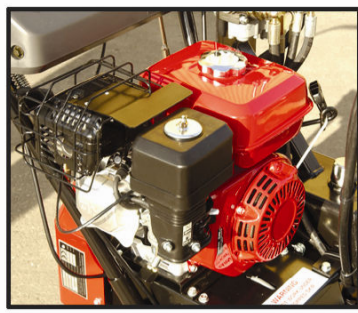

TD500 HL Hydraulic High Tip (500kg)

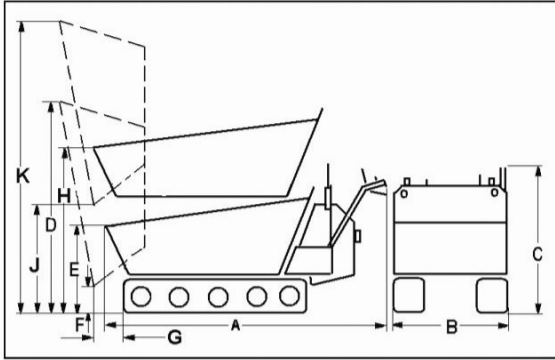

A Overall length	1.96m
B Overall width	0.68m
C Overall height	1.130m
D Maximum height when skip tipped (scissors lowered)	1.960m
E Skip loading height (scissors lowered)	0.7m
F Skip discharge height (scissors lowered)	0.80m
G Forward discharge distance	0.26m
H Skip loading height (scissors raised)	1.129m
J Skip discharge height (scissors raised)	1.220m
K Maximum height skip raised (scissors raised)	2.460m
Machine weight:	317 kg

TD650 **NEW** Hydraulic Standard Tip (650kg)

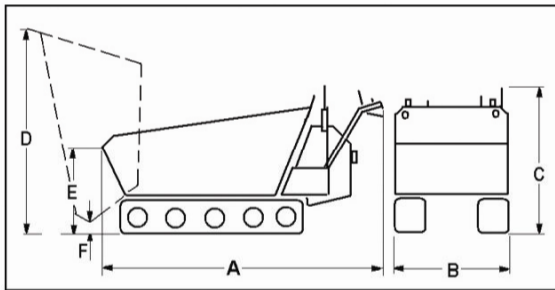

A Overall length	1.96m
B Overall width	0.68m
C Overall height	1.13m
D Maximum height when skip tipped	1.34m
E Skip loading height	0.6m
F Skip discharge height	0.02m
Machine weight:	249 kg

LUBRICANTS & CAPACITIES (Total-Fina factory fill)

Hydraulic Oil	Azzola ZS46 (capacity 5 litres)
Grease	Multis EP2
General lubricating oil (pivot pins)	Rubia B20W/30

PRESSURES

Hydraulic Pressure	2500psi (172 bar)
--------------------	-------------------

MAXIMUM PAYLOAD CAPACITY

	TD500HL	TD650
On level ground	500kgs	650kgs
On gradients	350kgs	350kgs

MAXIMUM GRADIENT

Maximum Downward Gradient	15°
Maximum Upward Gradient	20°

NOISE LEVELS

Operators Ear	85LPA
Directive 2000/14/EC	101LWA

TRAVEL SPEED

Forward Travel	0-4.3 km/h
Reverse Travel	0-3.6 km/h

VIBRATION AT HANDLEBARS

Hand/Arm Vibration (EN1033)	11 m/s@3600 rpm
-----------------------------	-----------------



Winget Limited, Edgefold Industrial Estate, PO Box 41, Plodder Lane, Bolton, BL4 0LS
Tel: 01204 854650, Fax: 01204 854664, email: sales@winget.co.uk, www.winget.co.uk
a **Seddon** Group Company

Due to a policy of continual improvement, the manufacturer reserves the right to change specifications without further notice.