

WINGET

MECHANICALLY FED MIXER
200TM



200TM



Standard Equipment

Chassis: Heavy duty, folded section chassis and outrigger legs lead to extra stability, reliability and durability.

Engine: Lister Petter hand start, air cooled diesel (electric start optional) TR1 5.5kW (7.4hp) @1500rpm
or 415 volt 3 phase, 50Hz, electric motor driven 4.1kW (5.5hp) @1440 rpm

Drum: Two piece, spun steel drum assures long life and easy replacement. Winget drum design ensures thorough, efficient mixing.

Driveline: Totally enclosed, heavy duty driveline through roller chain (diesel) or drive belt and chain (electric), cast bevel wheel and pinion.

Water Tank: Manually controlled filling and measured volume discharge. 38 litre capacity.

Feed Hopper: Hydraulically operated loading hopper with high discharge angle ensures rapid and clean feed of materials into drum. Hopper holds sufficient material for a full batch mix.

Capacities

	200TM
Mixed batch output (wet output)	200 ltrs
Nominal capacity (dry unmixed input)	285 ltrs
Gross drum volume	485 ltrs
Drum speed	22 rpm
Maximum production rate (per hour)	4 m ³
Dragline shovel capacity	140 ltrs

Optional Equipment

Electric Start: Diesel powered mixers use a hand start system as standard but can be specified with electric starting. A hand starting option is retained as a back-up.

Batchweigher: Facilitates accurate weighing of each type of aggregate. Includes a large weigh dial, clearly calibrated in 5kg increments and three adjustable markers further assist accuracy and consistent mix quality.

Dragline feeder: The Dragline Feeder maximises output from Winget hopper-fed mixers by enabling one man to keep the mixer continuously charged with materials. A powered feed shovel, under direct operator control through a switch on the shovel handle, is drawn towards the mixer on a wire rope operated by a hydraulic winch. The filled shovel is then discharged easily into the feed hopper.

Feed Apron: A converging steel ramp provides a direct path for the dragline feed shovel up to the feed hopper, greatly simplifying hopper charging. Dividing partitions keep coarse and fine aggregates separated. The feed apron also prevents aggregate from building up underneath the feed hopper, ensuring batchweigher accuracy by eliminating discrepancies which may otherwise result from material 'build-up'.

Dimensions

	200TM
A Overall length	2.36m
B Overall width (hopper lowered)	2.91m
C Hopper width	1.21m
D Width over wheels	1.64m
E Height to top of water tank	2.26m
F Overall height (with optional dragline feeder)	2.98m
G Discharge height	0.79m
H Height with hopper raised	2.97m
J Ground clearance (hopper)	0.12m
K Hopper loading height	0.49m
Machine weight (basic machine)	990kg
Cube (free standing in shipping format)	15.52m ³

200TM Mixer - dimensions

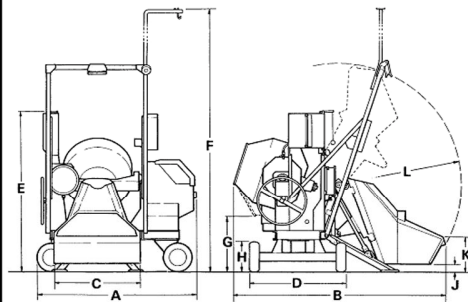

WINGET

Winget Limited
PO Box 41, Edgefold Industrial Estate
Bolton, BL4 0LS, England.

Tel: +44 (0)1204 854650, Fax: +44 (0)1204 854664
email: sales@winget.co.uk, www.winget.co.uk



a **Seddon** Group Company



Mixers for operation in the EC
are CE Marked

Due to a policy of continual improvement, the manufacturer reserves the right to change specifications without further notice.

Dealer Stamp