

WINGET

TURNER
POWERTRAIN SYSTEMS

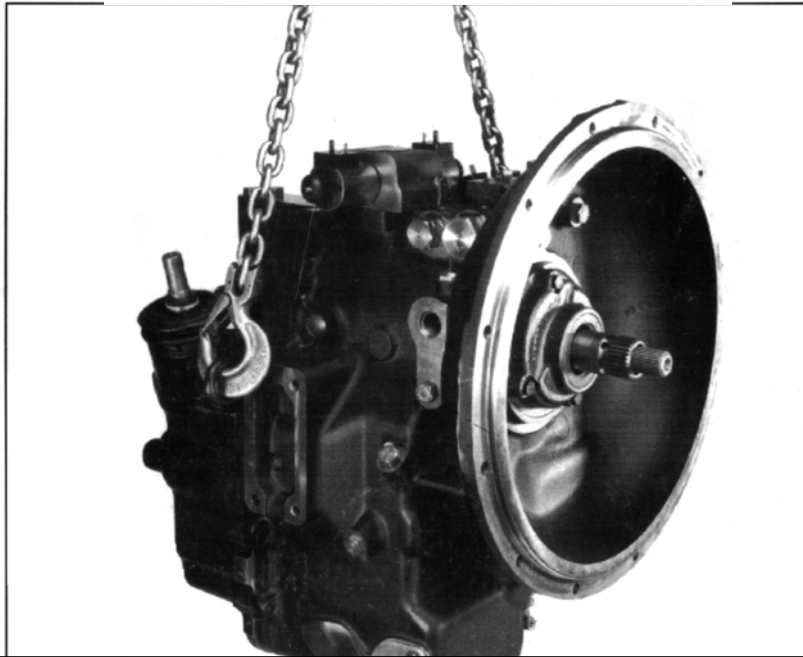

**WINGET LIMITED CANNOT ASSIST USERS OF EQUIPMENT THAT WAS
MANUFACTURED BY OTHER OEM'S**

**WINGET LIMITED WILL ONLY OFFER PARTS AND SERVICE ASSISTANCE
TO USERS OF EQUIPMENT MANUFACTURED BY WINGET LIMITED**

**PLEASE BE AWARE THAT SOME TRANSMISSION PARTS ARE NO
LONGER AVAILABLE**

COMPACT PLUS SERVICE MANUAL

WINGET LIMITED
PO BOX 41
EDGEFOLD INDUSTRIAL ESTATE
PLODDER LANE
BOLTON
LANCS
BL4 OLS

TEL: ++ 44 ((0) 1204 854650

FAX: ++ 44 (0) 1204 854663

service@winget.co.uk

parts@winget.co.uk

www.winget.co.uk

INTRODUCTION

The contents of this manual although correct at the time of publication, may be subject to alteration by the manufacturers without notice and Winget Limited can accept no responsibility for any errors or omissions contained within the following pages. Nor can Winget Limited accept any liability whatsoever arising from the use of this manual howsoever caused.

Winget Limited acknowledge that that the design and production of the following manual is the copyright of D Double U Design and Turner Powertrain Systems Ltd.

For authorised use only.

D.Double.U. Design
Star Works
Frederick Street
Wolverhampton
WV2 4DU

Tel: 01902 450022
Fax: 01902 450020

E.mail: info@ddoubleu.com
Web: www.ddoubleu.com

Technical Service Department
Turner Powertrain Systems Ltd.
Racecourse Road, Wolverhampton,
West Midlands, WV6 0QT. England.
Tel. 01902 833000 Fax 01902 831850



Compact Plus Transmission

Service and Repair Manual

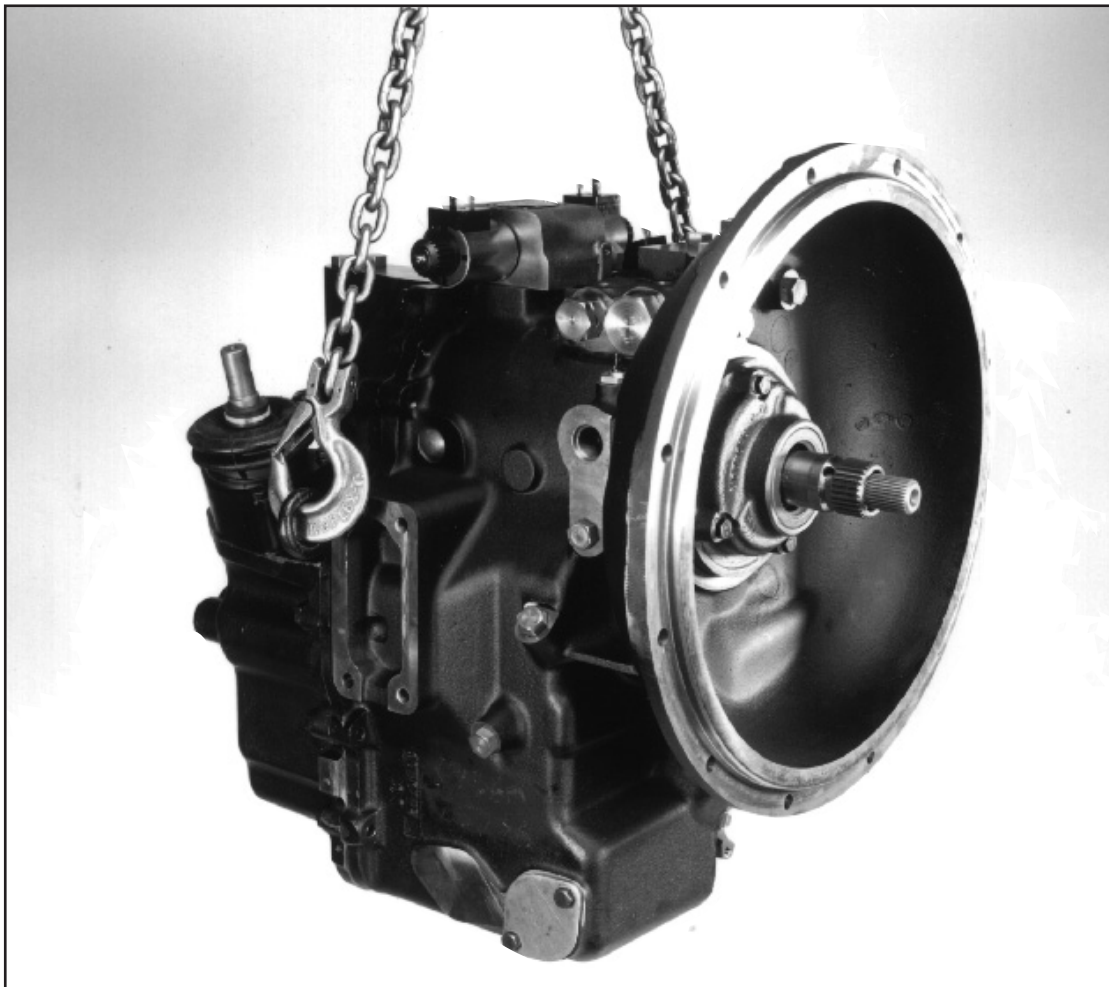

CONTENTS

Introduction.

Torque Converter Installation Guide.

Gear Ratios.

Lubrication.

Explanation of Hydraulic circuits.

Service Tools.

Technical Data.

Exploded Illustrations.

Strip and Rebuild Procedure:-

1. Transmission Disassembly.
2. Input shaft.
3. Countershaft.
4. Reverse Idler shaft .
5. Output shaft.
6. Hydraulic Dog Clutch 4wd.
7. Permanent 4wd.
8. Hydraulic Multi Plate Clutch 4wd.
9. Oil Pump.
10. Directional control valve.
11. Gear lever housing.
12. Transmission Re-assembly.
13. Test Ports and Pressures.
14. Parking Brake

Test Procedure

Fault Diagnosis.

INTRODUCTION

The Compact Plus is a synchroshift reversing shuttle with an integral 4 speed fully synchronised transmission. Designed for a variety of mobile off-highway applications, the Compact Plus allows in-motion shifting between forward and reverse without braking. It is suitable for use with engines in the 60 - 110 HP range.

Features :-

Available with or without a co-axial engine driven PTO drive to accommodate SAE B or C pumps.

Optional "soft shift" modulation to improve operator comfort during reversals.

Automotive shift pattern with reduced lever movements to allow greater freedom in cab design.

Ratio options and converter matches to maximise performance in all applications.

Electro-hydraulic directional and 4WD controls to eliminate cable and rod connections.

Optional parking brake, 4th gear lock out and harness connectors.

Optional 2 or 4 wheel drive configuration with hydraulic multi-plate clutch, hydraulic dog clutch or permanent mechanical engagement.



Turner Powertrain Systems Ltd.
Racecourse Road, Wolverhampton,
West Midlands, WV6 OQT. England.
Tel. 01902 833000 Fax. 01902 831850.

COMPACT PLUS WITH CO-AXIAL PUMP DRIVE AND HYDRAULIC DOG CLUTCH 4WD

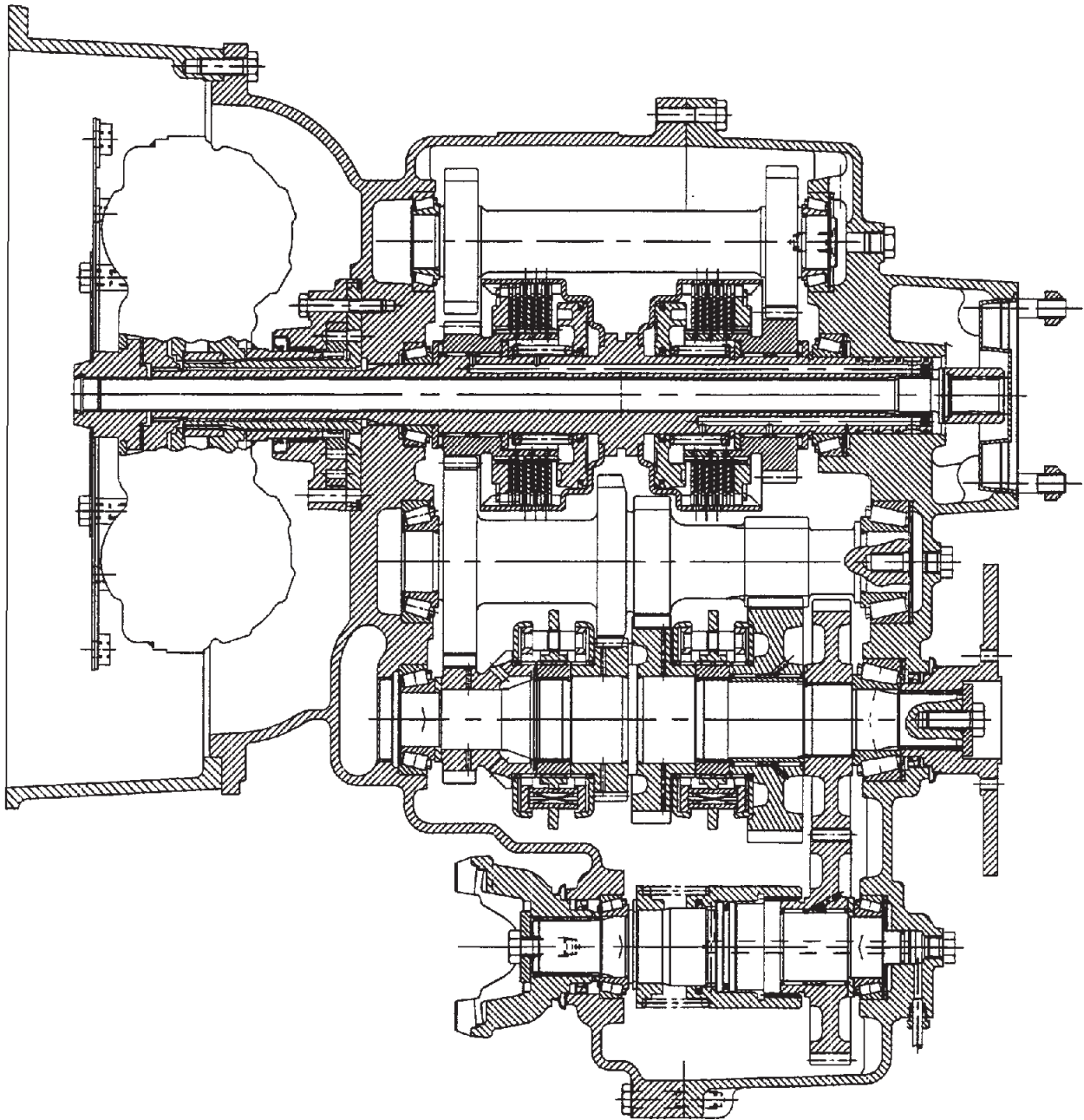

COMPACT PLUS WITH HYDRAULIC MULTI-PLATE 4WD

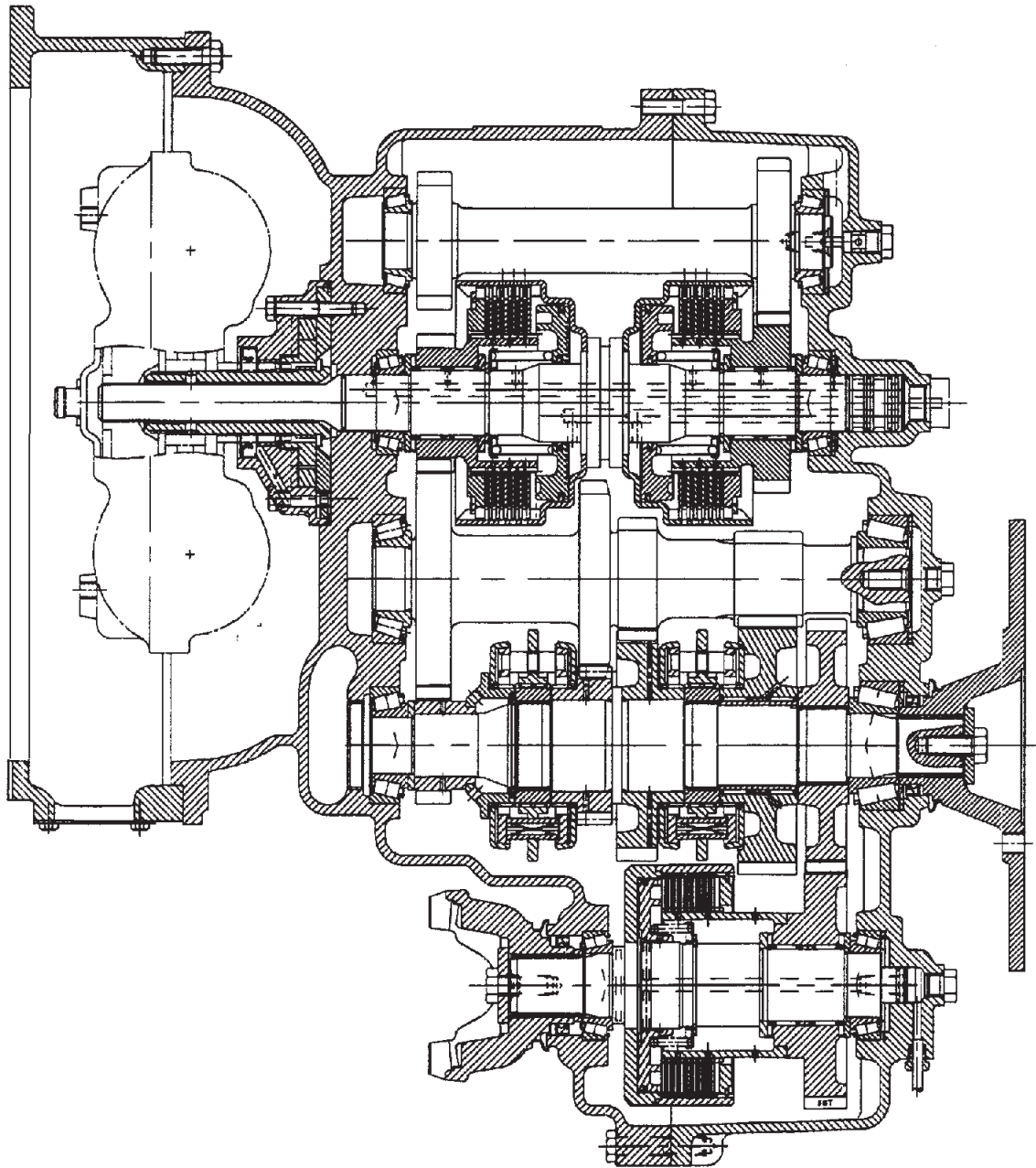

TORQUE CONVERTER INSTALLATION GUIDE

In order to ensure correct installation of the torque converter the following procedure is recommended :-

1. Attach a dial indicator to the engine flywheel and check that the runout of the flywheel housing bore dia. and the housing mounting face are within .008" T.I.R. With the dial indicator attached to the flywheel housing , check that the run-out of the flywheel pilot bore does not exceed .005" T.I.R.
2. Loosely assemble the drive plate to the converter.
Check that the outer bolt circle of the drive plate is concentric to the converter pilot dia. within .015" T.I.R.
Then torque the bolts to the manufacturers specification.
3. Apply an anti-seize compound to the pilot dia. of the converter.
4. Ensure that the converter drive tangs are correctly aligned with the transmission pump tangs, then assemble the torque converter and drive plate assembly onto the transmission.
Take care not to damage the pump oil seal or support bush.
Rotate the converter assembly to check that it is correctly engaged in the pump.
5. Assemble the transmission and converter assy. onto the engine and tighten the bell housing bolts.
Loosely fit the drive plate to flywheel bolts and rotate the converter several times to seat it, then torque the bolts to the manufacturers specification.

Note :-

If this procedure cannot be followed, due to the absence of an access hole in the flywheel housing, then the converter and drive plate assembly will have to be fitted to the engine first.

This method however is not recommended as the possibility of damaging the transmission pump or oil seal is greatly increased.

If this method must be used then the following check should be made :-
With the converter fitted to engine attach a dial indicator to the flywheel housing and check that the run-out of the converter drive hub does not exceed .008" T.I.R

COMPACT TRANSMISSION GEAR RATIOS

Model No.	Ratios							
	Forward				Reverse			
	1	2	3	4	1	2	3	4
COM T4-2018	6.285	3.905	1.532	0.850	5.635	3.501	1.374	0.762
COM T4-2024	4.824	2.998	1.408	0.792	4.824	2.998	1.408	0.792
COM T4-2025	4.824	2.998	1.408	0.792	4.020	2.496	1.173	0.660
COM T4-2026	6.119	3.238	1.665	0.950	6.119	3.238	1.665	0.950
COM T4-2029	6.285	3.905	1.710	0.850	5.635	3.501	1.533	0.762

Note :- Due to legal requirements certain applications have 4th gear blanked off in order to limit the maximum speed of the vehicle.

Shift Pattern at Gear Stub Lever

Front of Transmission



TRANSMISSION LUBRICATION

To ensure proper lubrication and operating temperatures it is most important that appropriate lubricants are used and that the correct oil level is maintained.

Oil Level Checking :-

The oil level should be checked daily and corrected if necessary.

The oil level must be checked with the engine idling and with the transmission oil cold. In this condition the oil level should fall between the Max and Min marks on the dipstick. At normal operating temperature, (80 Deg.C.) the oil level will rise to 20 - 30 mm above the Max. mark on the dipstick.

Do not overfill the transmission as this may result in oil breakdown due to excessive heat and aeration from the churning action of the gears. Early breakdown of the oil will result in heavy sludge deposits that block oil ports and build up on splines and bearings. Overfilling may also cause oil leaks.

Oil Changes:-

An initial oil change and flush is recommended after the transmission is placed in actual service. This change should be made at any time following 50 hours in service , but should not exceed 100 hours.

An oil change and flush should be scheduled for every subsequent 750 hours of operation. When changing the oil it is essential to renew the oil filter and clean out the suction strainer. The object in draining the oil is to eliminate possible bearing surface abrasion and attendant wear. Minute particles of metal, the result of normal wear in service are deposited in and circulated with the oil.

Oil changes are best carried out when the transmission is thoroughly warm

Caution :- Towing.

To prevent oil starvation and possible seizure of the transmission whilst towing the vehicle , it is imperative that the propeller shafts are disconnected.

Failure to observe this precaution may result in extensive damage to the transmission.

RECOMMENDED LUBRICANTS

10W or 10W 30 Grade mineral oils or automatic transmission fluids which meet at least one of the following specifications are allowable for use in ambient temperatures of between -20 and 40 Deg.C :-

A.P.I. GL4, Allison C3, MIL-L-2105B, or Caterpillar TO2.

The following lubricants meet these requirements :-

(Note - this list has been compiled for guidance only .Turner Powertrain or the appropriate oil company should be consulted on any specific application.)

<u>Oil Company</u>	<u>A.T.F.</u>	<u>Mineral Oils</u>
Mobil		Delvac 1310 or Mobilube HD 80
Shell	Donax TM or TA	Donax TC 10W.
B.P.	Autran MBX.	Vanellus C3 10W
Esso	Torque Fluid 56	Unifarm.
Castrol		Castrol RX 10 or Multiplant
Texaco	Texamatic C3 , 9230 or 9226.	
Total	Total Fluid ATX.	
Elf	Elfmatic G3 or Elfmatic H	
Fina	Finamatic HD	Kappa TD 10W

EXPLANATION OF COMPACT PLUS TRANSMISSION HYDRAULIC CIRCUITS

The Clutch Circuit.

Oil from the transmission sump is drawn up through the suction strainer by the pump.

It is forced, under pressure from the pump, through the full flow oil filter into the clutch circuit. To protect the filter during cold start up a relief valve dumps oil back to the sump should it exceed 26 bar pressure.

From the filter the oil flows through the main pressure regulator valve. This maintains the clutch system pressure at 14 bar.

From this valve oil also enters the Torque converter circuit.

The solenoid actuated direction control valve, when operated, sends oil from the clutch circuit to the forward or reverse clutch piston which then applies the appropriate clutch. When in neutral the valve closes and oil from the clutch pistons is returned to the sump.

On hydraulic 4 wheel drive models an additional solenoid valve, when actuated, sends oil from the clutch circuit to the 4wd clutch piston which then applies the clutch. When de-selected the valve closes and oil from the clutch piston is returned to the sump.

On "Sprung On" hydraulic 4wd models the dog clutch is engaged by a spring. To disengage the clutch the 4wd solenoid valve is actuated and the piston compresses the spring and disconnects the clutch.

The Torque Converter Circuit

Oil enters the converter circuit from the main pressure regulator valve.

It flows through passages in the oil pump housing and into the torque converter.

Pressure is controlled by the converter relief valve which prevents the pressure within the torque converter from exceeding the design limits.

(7 or 10 bar depending on the type of converter used).

Any excess is returned to the sump.

The Cooling and Lubrication Circuit.

Hot oil flows from the torque converter via the inside of the pump stator tube, through the centre of the oil pump , and out of the transmission via connecting hoses.

It is then passed through an external oil cooler before being returned to the transmission where it is used to cool the clutches and lubricate the input shaft bearings before being returned to the sump.

HYDRAULIC CIRCUIT DIAGRAM

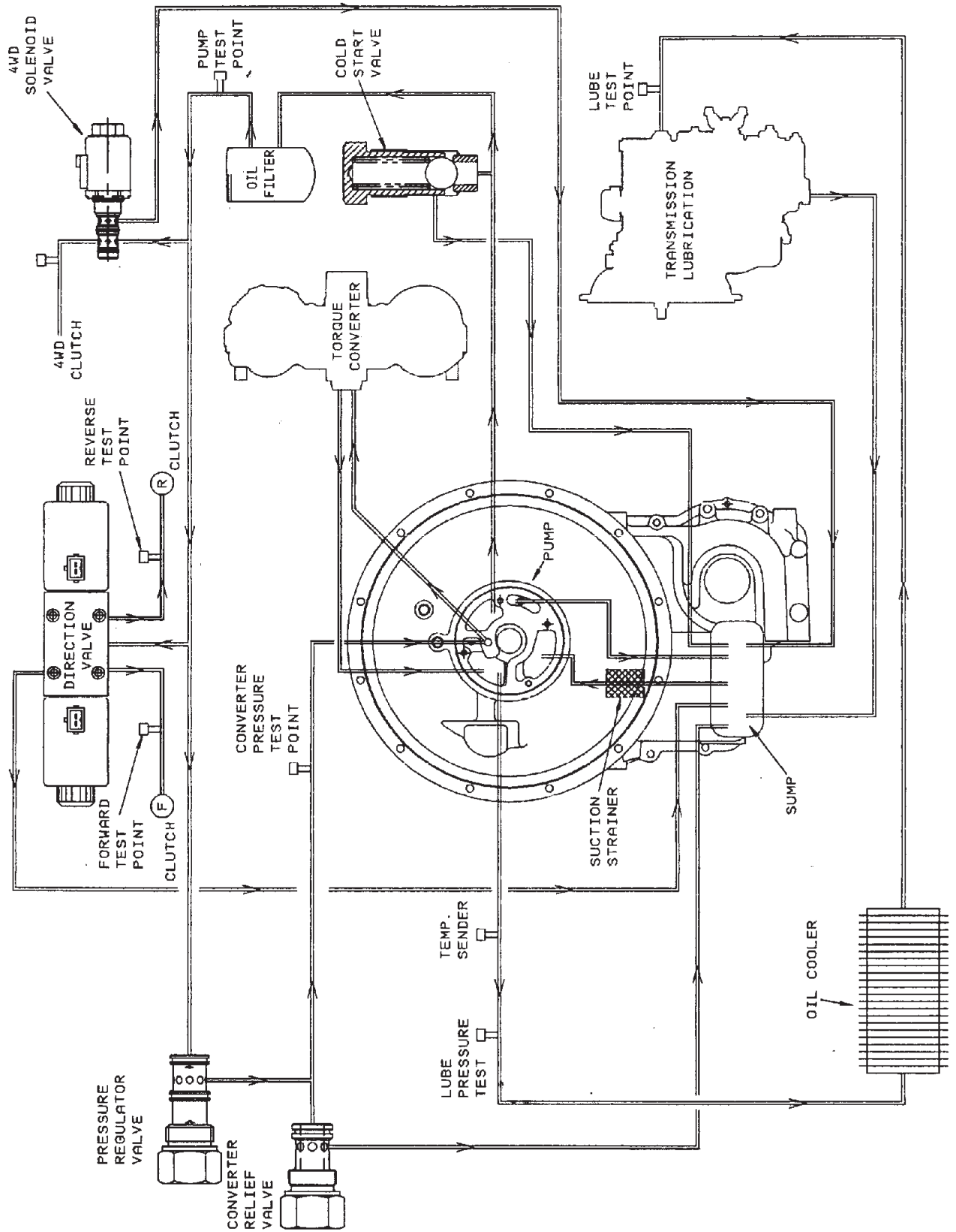

SPECIAL SERVICE TOOLS

<u>Tool Number</u>	<u>Description</u>
KM 3003 -	Bearing Extractor, use with brg. removal collets.
KM 3509 -	Input & Rev. Idler shaft brg. removal collet. Brg. Ref 48548 Pt.No.9713
KM 3510 -	Piston seal sizing ring. (Hydraulic 4WD only).
KM 3516 -	4wd shaft front \ rear and Co-axial input shaft front brg. removal collet. Brg. Ref 32008 Pt.No.68609
KM 3517 -	Output shaft front brg. removal collet. Brg. Ref 32207 Pt.No.68116
KM 3518 -	C/shaft and Output shaft rear brg. removal collet. Brg. Ref 33208 Pt.No.68608
KM 3519 -	Co-Axial Input shaft rear brg. removal collet. Brg. Ref 32010 Pt. No.68772
KM 3520 -	Input shaft spring compressor.
KM 3521 -	4wd shaft spring compressor. (Hydraulic multi plate 4WD only).
KM 3522 -	C/shaft front bearing removal collet. Brg.Ref 32208 Pt.No.65381
KM 3523 -	Co-Axial input shaft and Hydraulic dog clutch 4wd shaft spring compresser.
KM 3524 -	Shimming Adapter.

These service tools are available from:-

V L Churchill Ltd.P O Box 3, London Road, Daventry, Northants, England. NN11 4NF.
Tel. 01327 704461 Fax. 01327 871625.

RECOMMENDED TUBE SIZES FOR REPLACING BEARINGS

	<u>Tube Bore</u>	<u>Tube O/D</u>
C/shaft, 4wd, Output shaft rear & Co-axial input shaft front bearing.	41mm	47mm
Reverse idler, Output shaft front & input shaft bearing.	36mm.	41mm.
Output shaft 1st gear brg. sleeve and Co-axial input shaft rear bearing.	50.5mm	58mm

The dummy plug for re-fitting inner detent spring & ball can be made using a piece of bar 18mm dia. x 25mm long.

RECOMMENDED TUBE SIZES FOR REPLACING BEARINGS

	<u>Tube Bore</u>	<u>Tube O/D</u>
C/shaft, 4wd, Output shaft rear & Co-axial input shaft front bearing.	41mm	47mm
Reverse idler, Output shaft front & input shaft bearing.	36mm.	41mm.
Output shaft 1st gear brg. sleeve and Co-axial input shaft rear bearing.	50.5mm	58mm

The dummy plug for re-fitting inner detent spring & ball can be made using a piece of bar 18mm dia. x 25mm long.

TECHNICAL DATA

Shaft End Floats.

All shaft end floats should be 0.025 to 0.075 mm. (0.001 to 0.003 ins.)

Gear End Floats.

Input shaft forward and reverse primary gears - 0.061 to 0.41 mm. (0.0024 to 0.016 ins.)

Output Shaft Gears :-

4th Gear - 0.20 to 0.56 mm. (0.008 to 0.022 ins.)

3rd Gear - 0.38 to 0.84 mm. (0.015 to 0.033 ins.)

2nd Gear - 0.36 to 0.56 mm. (0.014 to 0.022 ins.)

1st Gear - 0.33 to 0.51 mm. (0.013 to 0.020 ins.)

4 Wheel Drive Output gear. - 0.051 mm. to 0.28 mm. (0.002 to 0.011 ins.)

Bolt Torques.

Strainer bolts.	18 to 31 Nm.	13 to 23 lb ft.
Pump retaining bolts.	18 to 31 Nm	13 to 23 lb ft.
.		
Output Yoke bolts.	68 to 88 Nm.	50 to 65 lb ft.
Pressure test plugs.	41 to 54 Nm.	30 to 40 lb ft.
Main transmission case bolts.	45 to 64 Nm.	33 to 47 lb ft.
Shift detent plug.	41 to 54 Nm.	30 to 40 lb ft.
Shift fork screws.	18 to 25 Nm.	13 to 18 lb ft.
Shift lever assembly screws.	16 to 24 Nm	12 to 18 lb ft.
Drain plugs	34 to 54 Nm.	25 to 40 lb ft.

TECHNICAL DATA CONTD.

Converter relief valve.	23 to 30 Nm.	17 to 22 lb ft.
Pressure regulator valve.	46 to 60 Nm.	34 to 44 lb ft.
Cold start valve.	46 to 60 Nm.	34 to 44 lb ft.
4WD solenoid valve spool.	20 to 27 Nm.	15 to 22 lb ft.
4WD Solenoid coil retaining nut.	5.4 Nm. Max.	4 lb ft. Max.
Directional control valve ret. screws.	6.8 to 8.5 Nm.	5 to 6.3 lb ft.
4WD hydraulic pipe connections.	6.8 to 10.2 Nm.	5 to 7.5 lb ft.
Filter housing bolts.	45 to 64 Nm.	33 to 47 lb ft.
Oil filter.	7 to 10 Nm.	5 to 7.5 lb ft.
Temperature sender.	20 to 27 Nm.	15 to 20 lb ft.

Recommended Sealants.

Transmission case joint.	Loctite 5203
4wd Output gear	Loctite 649 spline lock.
4wd gear (Permanent 4wd assy.)	Loctite 649 spline lock.
4wd clutch supply pipe.	Loctite 542.
Gear lever housing.	Loctite 5900 RTV jointing compound.
Shimming access expansion plug.	Loctite 649.
Filter housing gasket.	This gasket is graphite coated and should be fitted dry. Do not use sealant.

COMPACT PLUS WITH CO-AXIAL PTO DRIVE AND SPRUNG-ON 4WD

Key to Transmission Components.

1. Front gear case assembly.
2. Rear gear case assembly.
3. Plug assembly.
4. Bolt.
5. Bolt.
7. Bolt.
8. Reverse shift hub sleeve.
9. Synchroniser assembly.
10. Sealing ring.
11. Copper washer.
12. Thrust bearing.
13. 4wd piston sealing ring.
14. Support washer.
15. Torque converter.
16. O Ring 4wd piston.
17. Circlip.
18. Clutch collar.
19. Spring 4wd.
21. Spring support.
22. Flywheel housing.
23. Parking brake assembly.
24. 4wd Shaft.
25. 4wd Gear.
26. Converter drive plate.
27. Thrust washer.
28. 4th Gear Output shaft.
29. 3rd Gear Output shaft.
30. 2nd Gear Output shaft.
31. 1st Gear Output shaft.
32. 4wd Gear Output shaft.
33. Bearing 1st Gear Output shaft.
34. Bearing spacer.
35. Bearing sleeve.
36. Circlip.
37. Sealing ring 4wd shaft.
38. Bearing spacer.
- 39-42. Shim
43. Thrust washer.
44. Bearing spacer.
- 45-50. Shim.
51. Bearing.
52. Output shaft.
53. Bearing.
54. Bearing spacer.
- 55-58. Shim.
59. Bearing.
60. Bearing.
61. Bearing.
62. Thrust washer.
63. Countershaft.
64. Reverse idler gear.
65. Input shaft assembly Co-axial.
66. Forward primary gear.
67. Reverse primary gear.
68. Clutch pack retaining ring.
69. Clutch pack retaining plate.
70. Clutch plate - steel.
71. Clutch plate - friction.
72. Circlip.
73. Spring retainer.
74. Piston return spring.
75. Clutch piston.
76. Piston sealing ring.
77. O Ring.
78. Piston sealing ring.
79. O Ring.
80. Brake calliper bolt.
81. End yoke.
82. Spacer ring.
83. Needle bearing spacer.
84. Bolt
85. Needle bearing.
86. Bearing.
87. Output flange washer.
89. Screw.
90. O Ring.
91. Brake flange assembly.
92. Pump assembly.
93. Sealing ring.
94. Sealing ring.
95. Detent ball.
96. Detent spring.
97. 1st/2nd Shift fork.
98. 3rd/4th Shift fork.
99. 1st/2nd shift rod.
100. 3rd/4th Shift rod.
101. Shift fork screw.
102. Gear stub lever.
103. Bolt.
104. Gear lever seating.
105. Pin.

KEY TO TRANSMISSION COMPONENTS CONTD.

- 106. Rubber boot.
- 107. Washer.
- 109. Hydraulic pipe nut.
- 110. Plastic clip.
- 111. Plastic clip.
- 112. Plug.
- 113. Converter relief valve.
- 114. Setscrew.
- 115. Banjo bolt washer.
- 116. 4WD Clutch supply pipe.
- 118. Drain plug assembly.
- 119. Hydraulic pipe sleeve.
- 120. Bearing spacer.
- 121-124. Shim
- 125. Cold start spring housing.
- 126. Co-axial drive shaft.
- 127. Capscrew.
- 128. Pressure regulator valve.
- 129. 4wd solenoid valve.
- 130. Directional control valve.
- 131. Oil filter.
- 132. Oil filter adapter.
- 134. Dowel.
- 135. Oil seal.
- 136. Sealing cap.
- 137. Suction strainer.
- 138. O Ring suction strainer.
- 139. Support washer.
- 140. Strainer cover plate.
- 141. Setscrew.
- 142. Breather.
- 143. O Ring.
- 146. O Ring.
- 149. Expansion plug.
- 150. Brake calliper nut.
- 151. Pump mounting stud.
- 152. Oil filter housing.
- 153. Filter housing gasket.
- 154. Bolt.
- 155. O Ring.
- 156. Cold start spring.
- 157. Ball.
- 158. Setscrew.
- 160. Setscrew.
- 161. Copper washer.
- 162. Banjo bolt.
- 163. Remote test port assembly.
- 164. Remote test port pipe.
- 165. Remote test port pipe.
- 168. Pump mounting stud nut.
- 170. 4wd gear bearing.
- 171. Spacer 4wd gear bearings.

COMPACT PLUS WITH CO-AXIAL PUMP DRIVE AND HYDRAULIC DOG CLUTCH 4WD

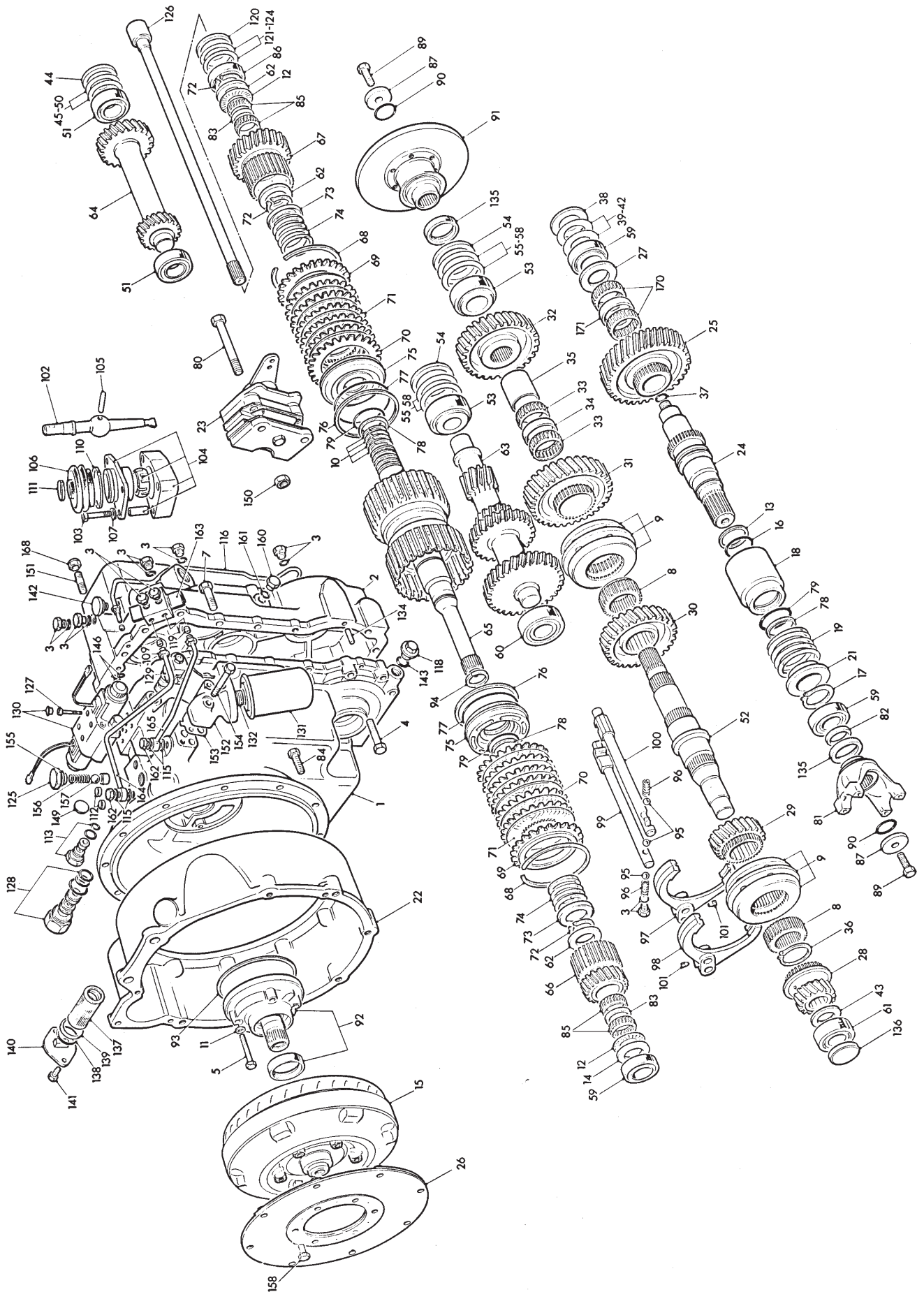

KEY TO HYDRAULIC MULTI-PLATE CLUTCH 4WD COMPONENTS

- 13. O Ring
- 16. Piston return spring.
- 17. Piston seal outer.
- 18. Piston
- 19. Clutch plate (friction).
- 21. Clutch plate
- 24. Shaft and drum assembly.
- 25. 4wd Gear assembly.
- 27. Thrust washer.
- 37. Sealing ring.
- 38. Spacer.
- 39-42. Shim.
- 59. Bearing.
- 80. Spring retainer.
- 81. End yoke assembly.
- 82. End yoke spacer.
- 87. End yoke washer.
- 89. Screw.
- 90. O Ring.
- 109. Clutch pack retaining ring.
- 120. Circlip.
- 121. Clutch pack retaining ring.
- 135. Oil seal.
- 156. Thrust washer.
- 157. Thrust bearing.
- 158. Bearing spacer.
- 159. Needle bearing.

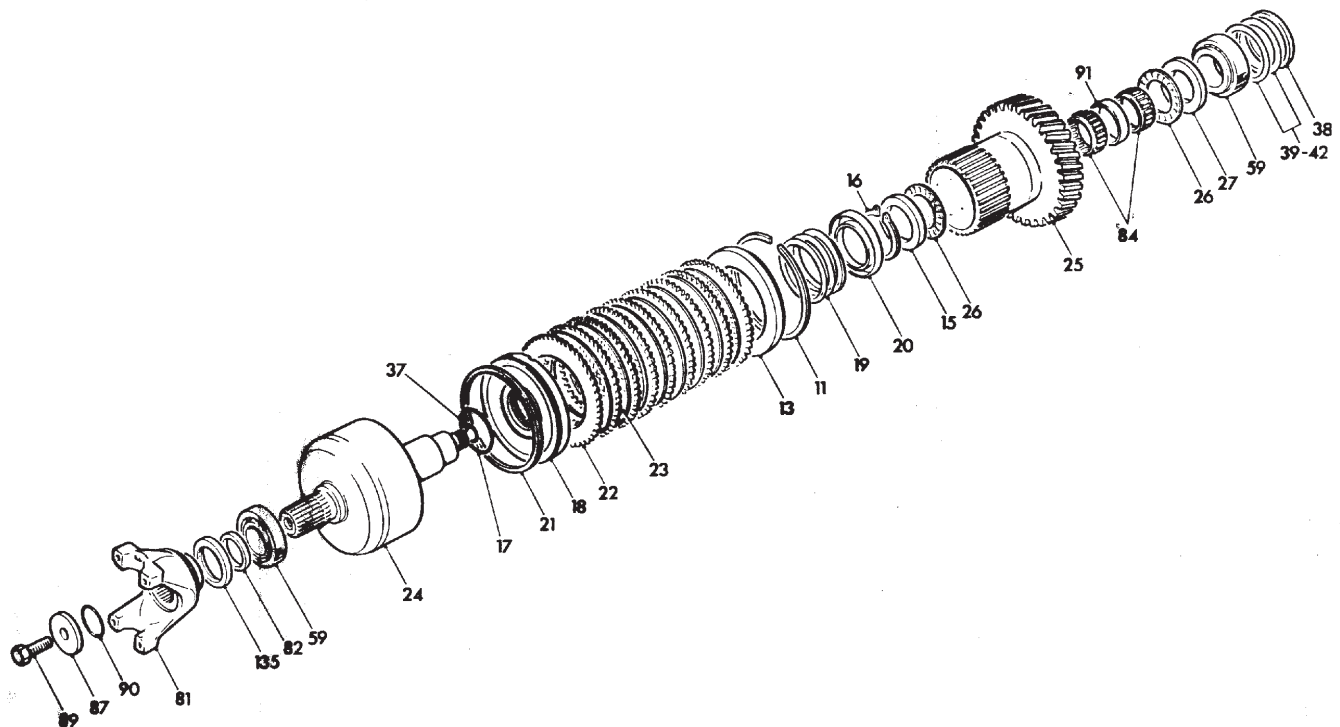

KEY TO TRANSMISSION COMPONENTS 2WD

1. Front gear case assembly.
2. Rear gear case assembly.
3. Plug and O ring.
4. Cold start spring housing.
5. Bolt.
6. Sealing Cap.
7. Bolt.
8. Reverse shift hub sleeve.
9. Synchroniser assembly.
10. Sealing ring.
11. Copper washer.
12. Thrust bearing.
14. Thrust washer.
17. Ball.
18. Cold start spring.
19. O Ring.
20. Plug.
21. Oil filter housing.
22. Flywheel housing.
23. Washer.
24. Filter housing gasket.
25. Bolt.
26. Cover plate.
27. Setscrew.
28. 4th Gear output shaft.
29. 3rd Gear output shaft.
30. 2nd Gear output shaft.
31. 1st Gear output shaft.
32. Spacer.
33. Bearing.
34. 1st gear bearing spacer.
35. 1st Gear bearing sleeve.
36. Circlip.
37. Expansion plug.
38. Directional valve.
40. O Ring.
43. 4th Gear thrust washer.
44. Bearing spacer.
- 45-50. Shim.
51. Bearing.
52. Output shaft.
53. Bearing.
54. Bearing spacer.
- 55-58. Shim.
59. Support washer.
60. Bearing.
61. Bearing.
62. Thrust washer.
63. Countershaft.
64. Reverse idler gear.
65. Input shaft assembly.
66. Forward primary gear.
67. Reverse primary gear.
68. Clutch pack retaining clip.
69. Clutch pack retaining plate.
70. Clutch plate.
71. Clutch plate (friction).
72. Circlip.
73. Spring retainer.
74. Piston return spring.
75. Piston.
76. Piston sealing ring outer.
77. O Ring.
78. Piston sealing ring inner.
79. O Ring.
80. Breather plug.
81. Capscrew.
82. Breather.
83. Needle bearing spacer.
84. Bolt.
85. Needle bearing.
86. Temperature sender.
87. Output Yoke washer.
88. O Ring.
89. Screw.
90. O Ring.
91. End yoke assembly.
92. Pump assembly.
93. Pump sealing ring.
94. O Ring.
95. Detent ball.
96. Detent spring.
97. 1st / 2nd Shift fork.
98. 3rd / 4th Shift fork.
99. 1st / 2nd shift rod.
100. 3rd / 4th shift rod.
101. Shift fork screw.
102. Gear shift lever.

KEY TO TRANSMISSION COMPONENTS CONTD.

- 103. Bolt.
- 104. Gear lever seating.
- 105. Pin.
- 106. Rubber boot.
- 107. O Ring.
- 108. Suction strainer.
- 109. Pressure regulator valve.
- 110. Plastic clip.
- 111. Plastic clip.
- 112. Plug.
- 113. Converter relief valve.
- 114. Setscrew.
- 115. Oil seal.
- 116. Oil filter.
- 117. Oil filter adapter.
- 118. Drain Plug.
- 120. Dowel.
- 121. Strainer cover plate.

COMPACT PLUS 2WD

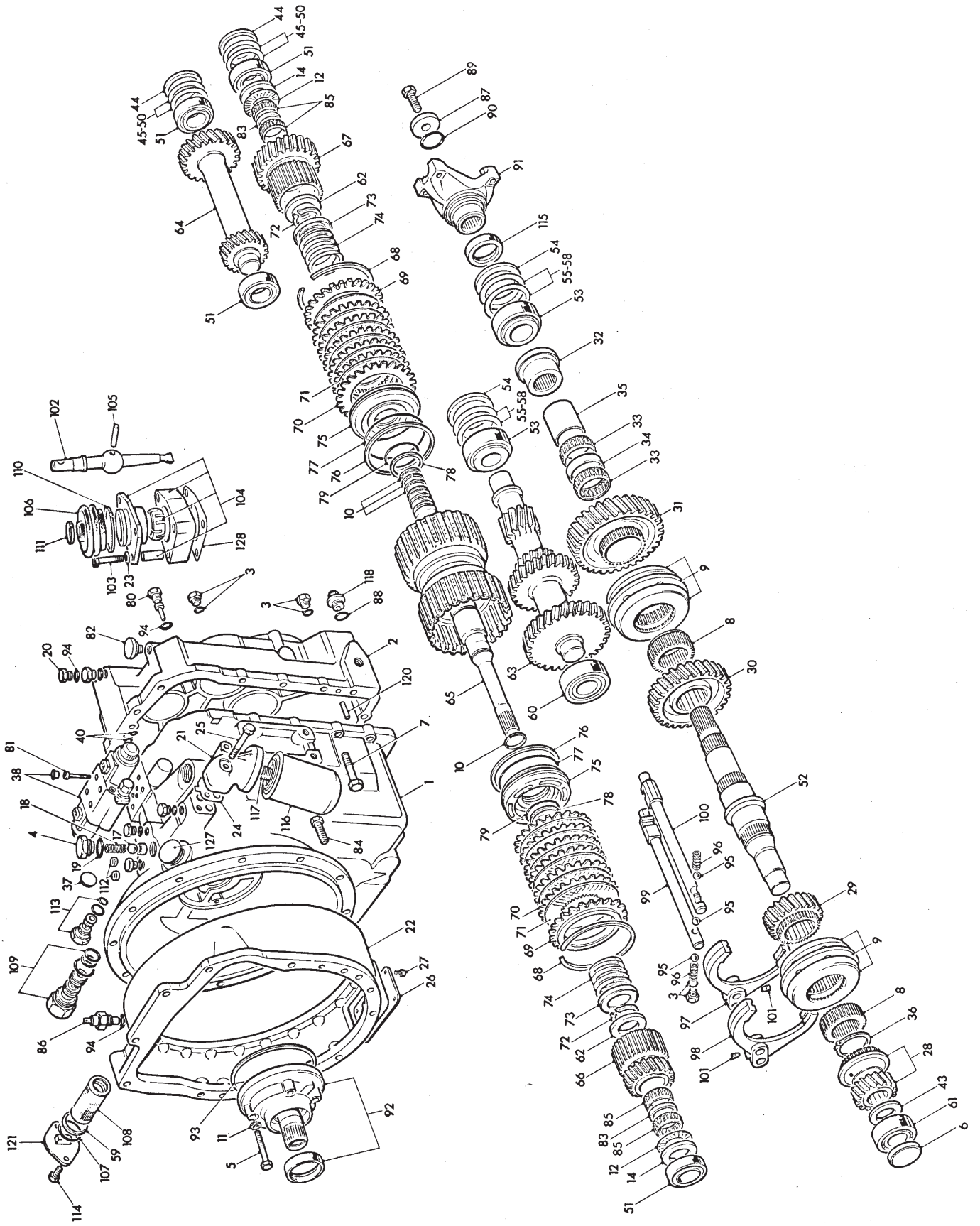

TRANSMISSION DISASSEMBLY



1:1 Invert the transmission on a suitable bench. For convenience the bench top should have a hole in it to accommodate the input shaft and pump. Remove 3 screws and withdraw the gear shift lever assembly.



1:4 Remove the Pressure Regulator Valve.

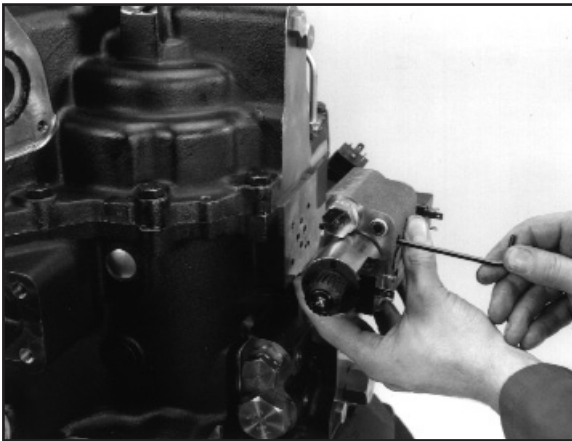

1:2 Remove the plastic plugs and 4 cap screws and withdraw the direction control valve.

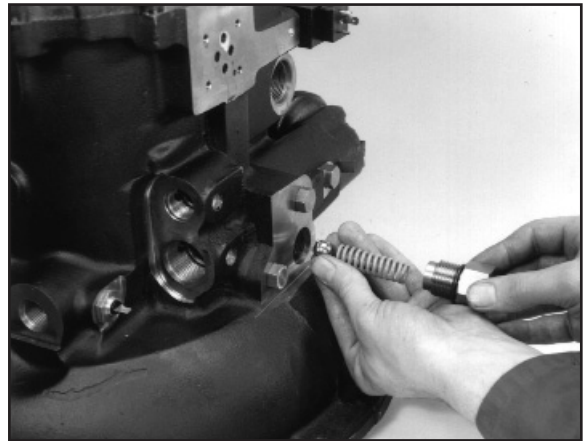

1:5 Remove the cold start housing, spring and ball.



1:3 Remove the Converter Relief Valve.

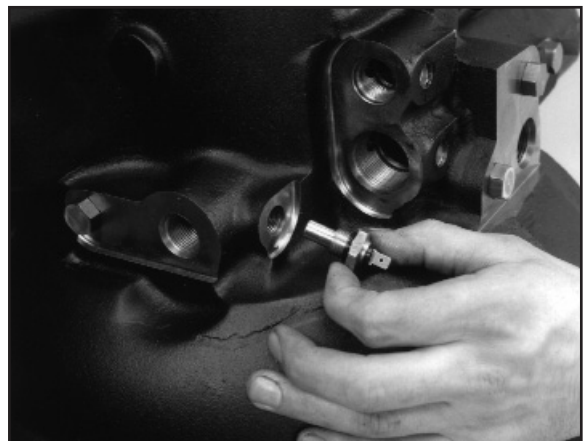

1:6 Remove the temperature sender.

TRANSMISSION DISASSEMBLY

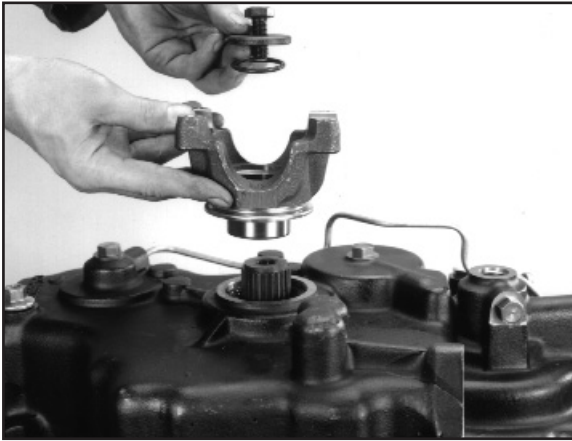

1:7 Remove the bolt, washer and O ring and withdraw the output yoke.

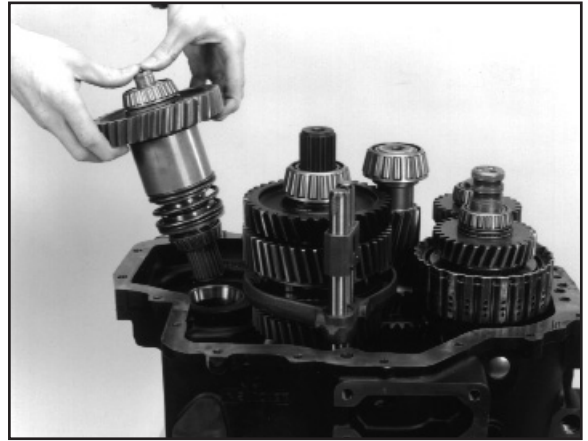

1:10 Remove the 4 wheel drive shaft assembly. (Not fitted on 2 wheel drive model.)

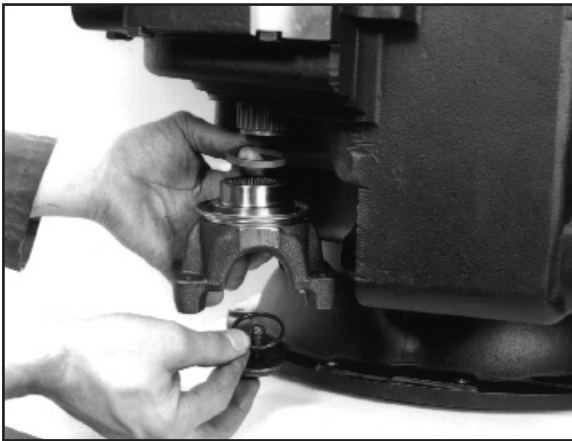

1:8 Remove the bolt, washer and O ring and withdraw the 4 wheel drive yoke and spacer. (Not fitted on 2 wheel drive model.)

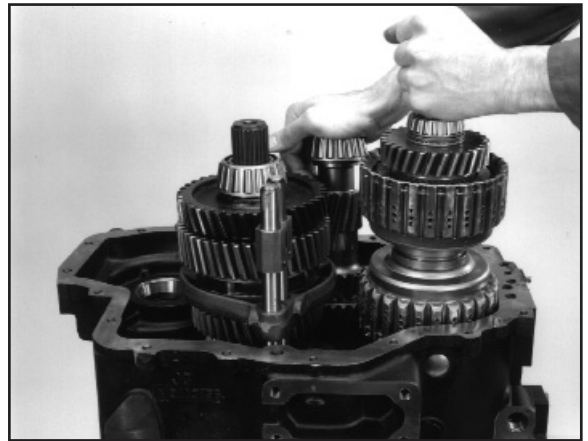

1:11 Tilt the countershaft and withdraw the input shaft assembly.



1:9 Remove 17 screws and using a suitable hoist take off the rear transmission case. Lever slots are provided to assist removal.

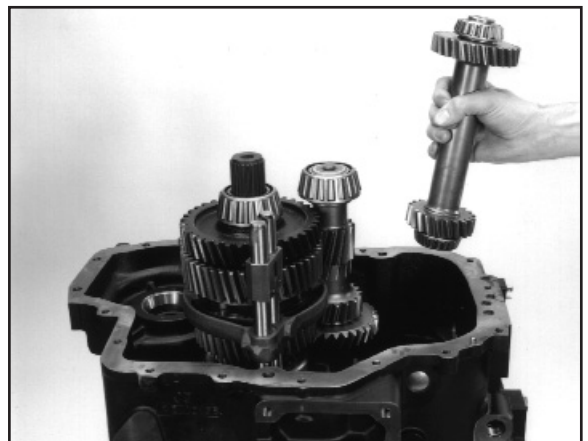

1:12 Remove the reverse idler shaft assembly.

Note :- The bearing cones and shims may fall from the rear case during removal.

TRANSMISSION DISASSEMBLY



1:13 Remove the outer detent plug , spring and ball.



1:16 Remove the 3rd / 4th shift fork screw.
Safety Note:- before attempting to remove the 3 / 4th shift rail, replace the detent plug as the ball and spring may shoot out and cause injury.

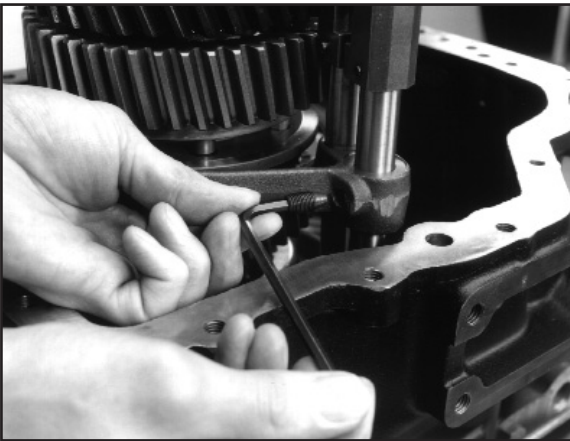

1:14 Ensure both synchronisers are in the neutral position then remove the 1st / 2nd shift fork screw.

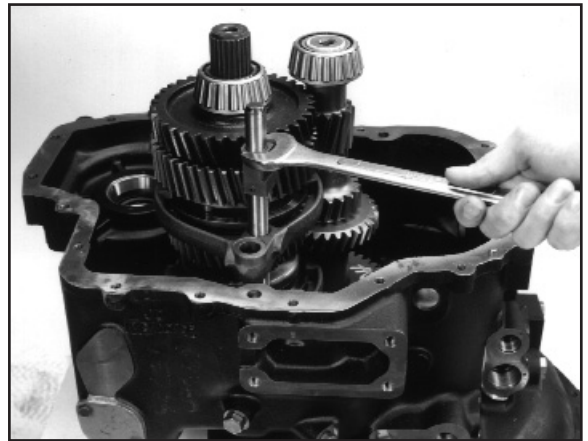

1:17 Turn the 3rd / 4th shift rod through 90 degrees and withdraw from the housing.

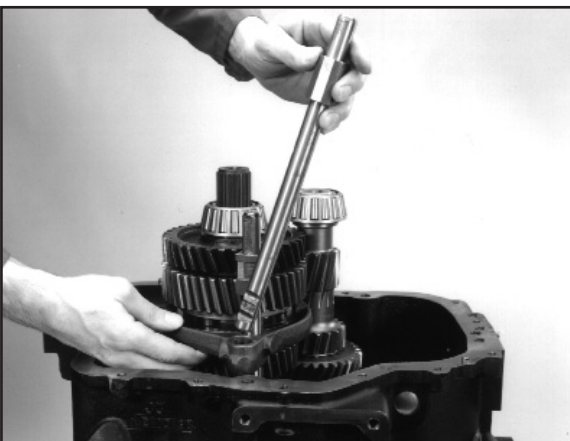

1:15 Withdraw the 1st / 2nd shift rod from the housing. Then using a magnetic probe remove the interlock ball from the detent bore.



1:18 Remove the detent plug, inner detent ball and spring.

TRANSMISSION DISASSEMBLY



1:19 Remove the counter shaft assembly.

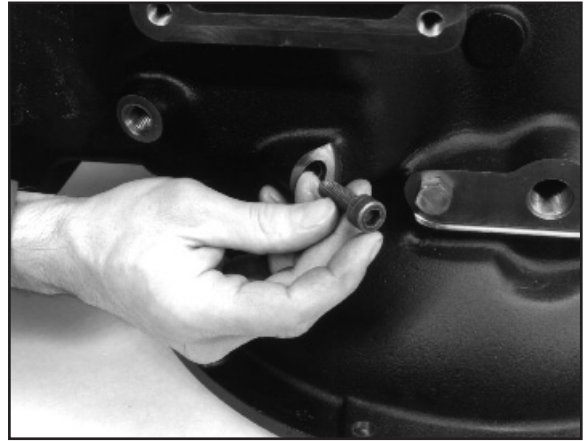

1:22 Remove the 4th gear lock out screw.
(If fitted.)



1:20 Remove the 1st / 2nd and 3rd / 4th
shift forks.



1:23 Remove 2 screws and withdraw the strainer
cover, O ring, spacer and strainer.

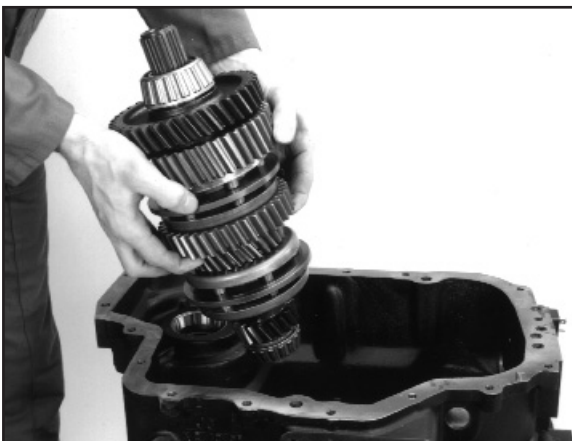

1:21 Remove the output shaft assembly.

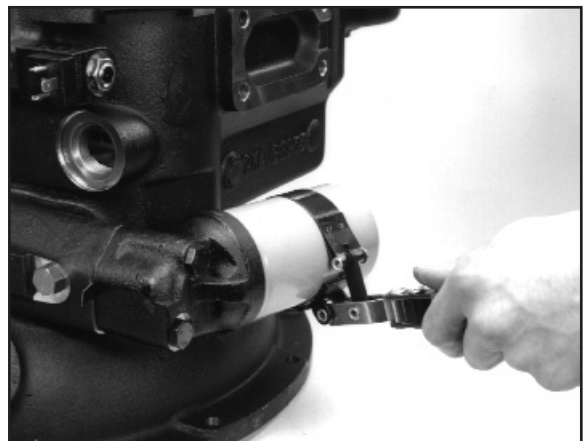

1:24 Using a strap wrench remove and discard
the oil filter.

TRANSMISSION DISASSEMBLY

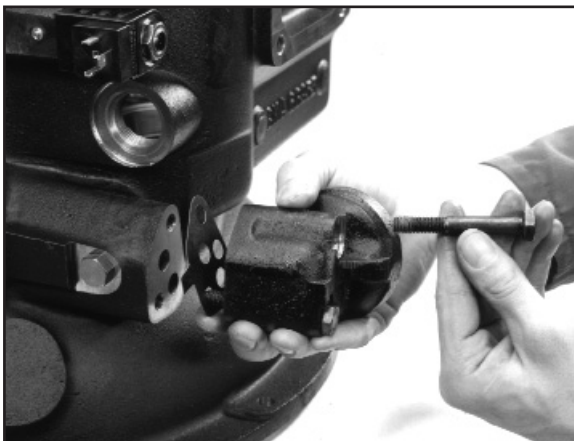

1:25 Remove 2 bolts and take off the oil filter housing and gasket.



1:28 Remove and discard the expansion plug from the shimming access hole.

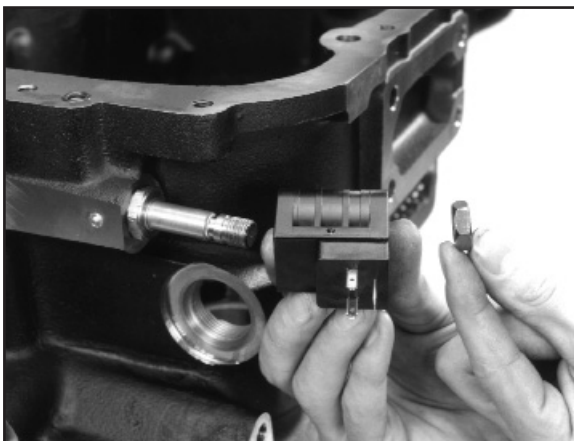

1:26 Remove the 4 wheel drive solenoid coil and retaining nut.
(Only fitted on 4 wheel drive model.)



1:29 Invert the case. Remove 4 screws and copper washers then withdraw the pump assembly and sealing ring.

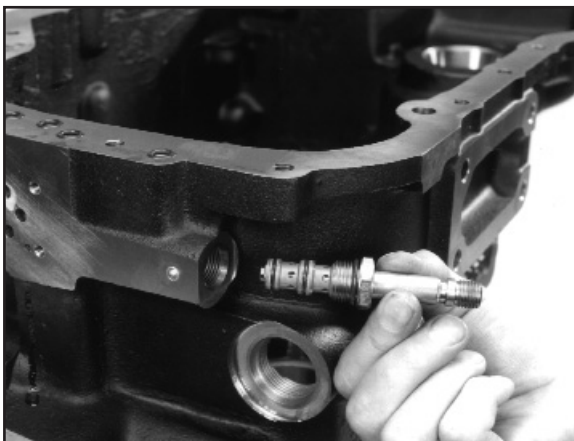

1:27 Remove the 4 wheel drive solenoid spool.
(Only fitted on 4 wheel drive model.)

INPUT SHAFT DISASSEMBLY

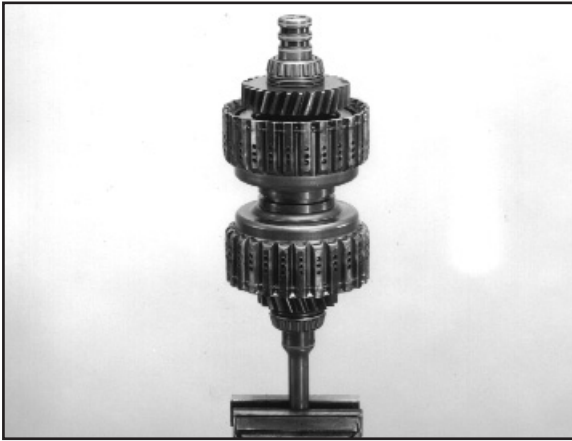

2:1 Position the shaft in a soft jawed vice as shown.

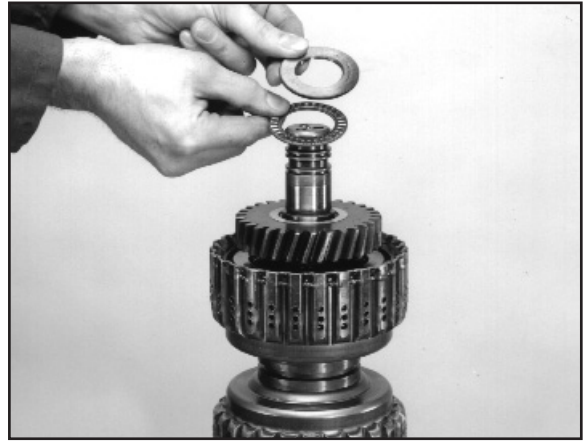

2:4 Remove the thrust washer and needle bearing.



2:2 Remove and discard the 3 sealing rings.

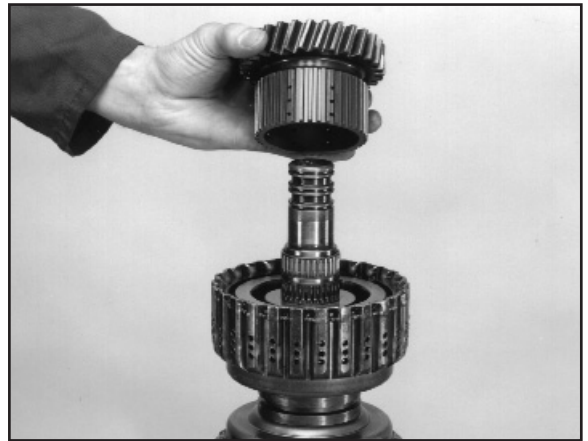

2:5 Remove the reverse primary gear.



2:3 Using the appropriate bearing puller remove the rear bearing. (Tool No.KM3509)



2:6 Remove the bearing, spacer, bearing and thrust washer.

INPUT SHAFT DISASSEMBLY

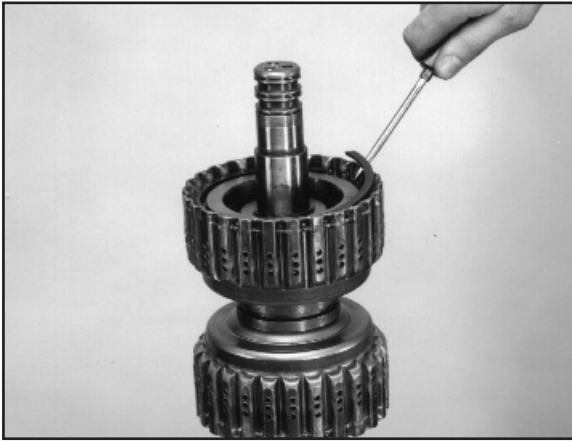

2:7 Remove the clutch pack retaining ring.

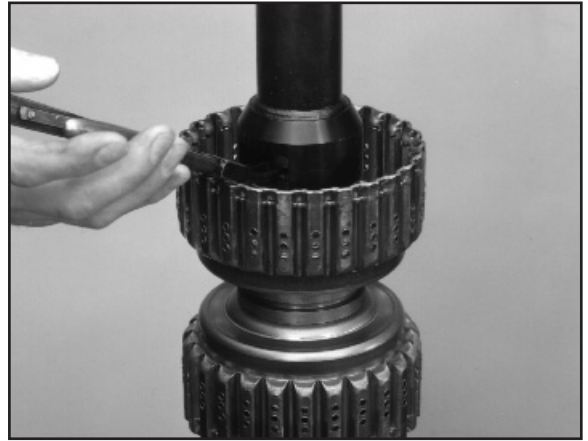

2:10 Using the appropriate tool compress the piston spring and release the circlip. (Tool No.KM3520)

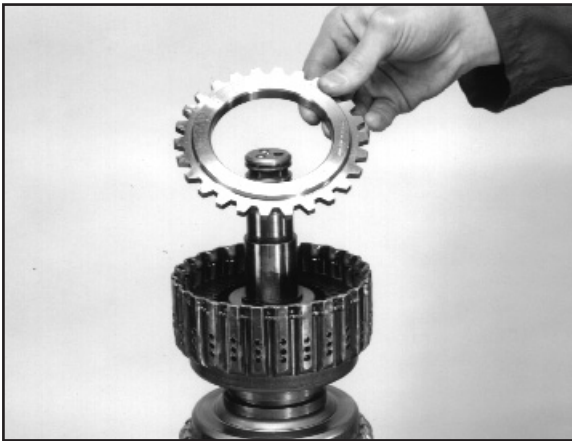

2:8 Remove the clutch pack retaining plate.



2:11 Remove the circlip, retainer and spring.



2:9 Remove the clutch pack.



2:12 Using pliers, as shown, pull the piston out of the drum.

INPUT SHAFT DISASSEMBLY

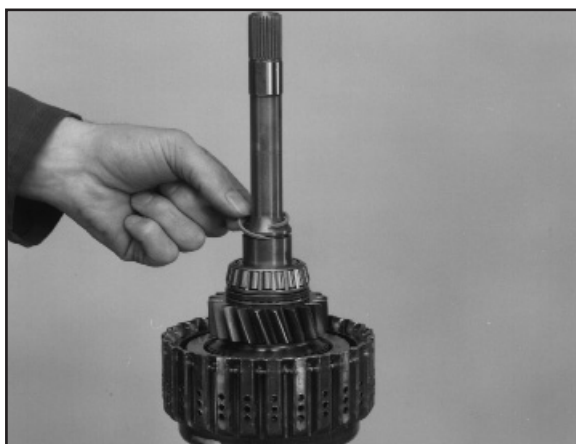

2:13 Invert the shaft and remove the sealing ring. Repeat steps 2:3 to 2:12 to dismantle the forward clutch pack.

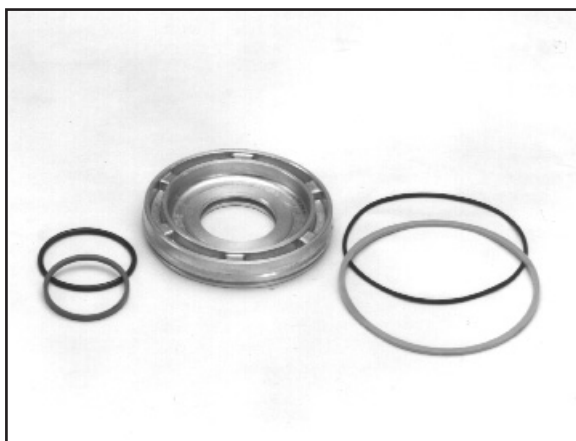

2:14 Remove and discard the piston sealing rings and O rings.

RE-ASSEMBLY OF THE INPUT SHAFT



2:15 Re-new the piston sealing rings and O rings. To assist assembly bend the inner sealing ring into a heart shape as shown.



2:18 Using the appropriate tool compress the spring and locate the circlip into its groove. (Tool No.KM3520)

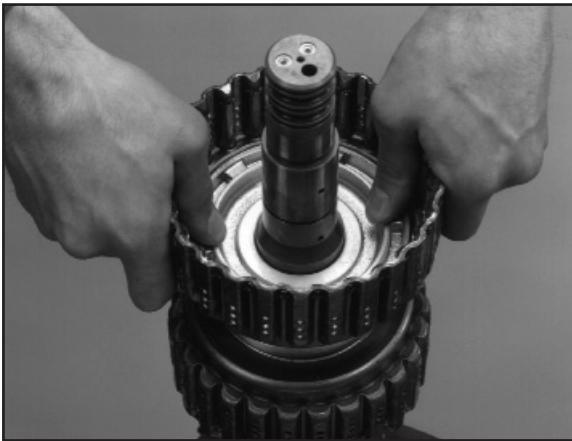

2:16 Using transmission fluid to lubricate the seals push the piston into the drum.

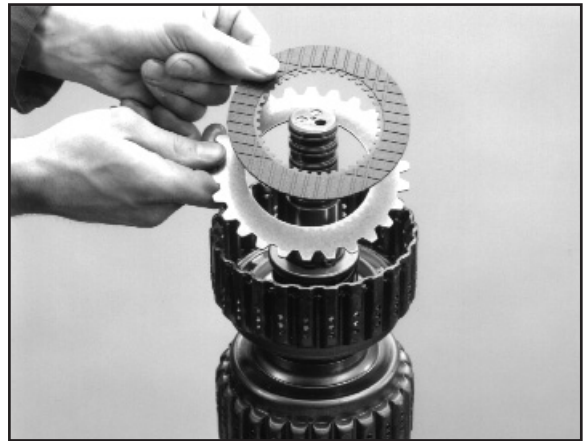

2:19 Replace an externally splined (plain) disc and then an internally splined (friction)disc alternately until six of each have been replaced.



2:17 Replace the spring , retainer and circlip as shown.

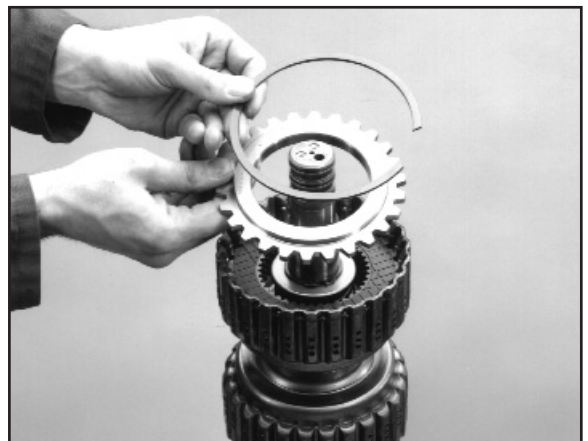

2:20 Replace the clutch pack retaining plate and re-fit the retaining clip.

RE-ASSEMBLY OF THE INPUT SHAFT

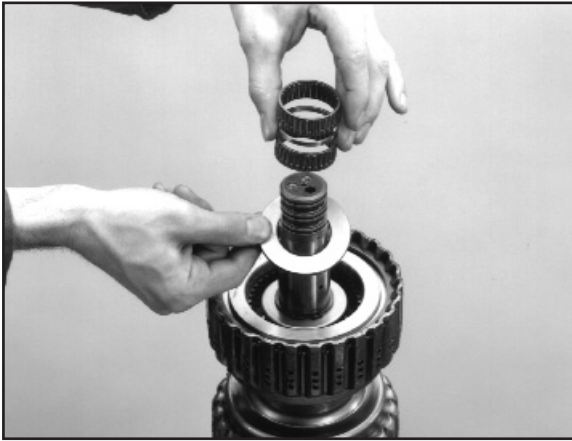

2:21 Replace the thrust washer, bearing, spacer and bearing.

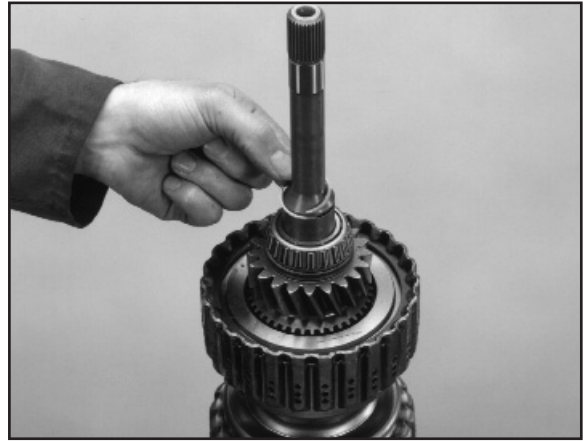

2:24 Invert the shaft and repeat steps 2:15 to 2:23. Then fit a new sealing ring as shown.

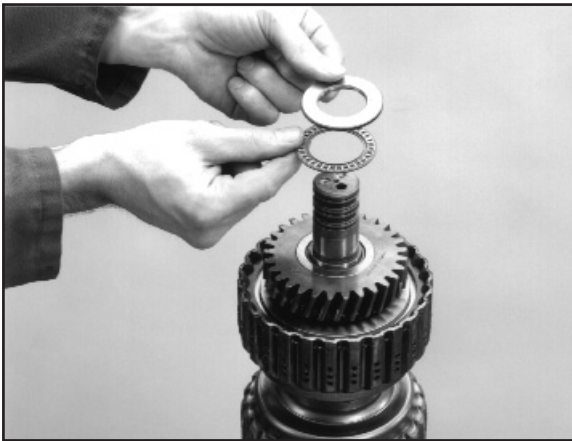

2:22 Line up the clutch plate splines and replace the primary gear. Then replace the needle bearing and thrust washer as shown.
Note: The needle bearing should be fitted with the closed side of its cage against the gear.

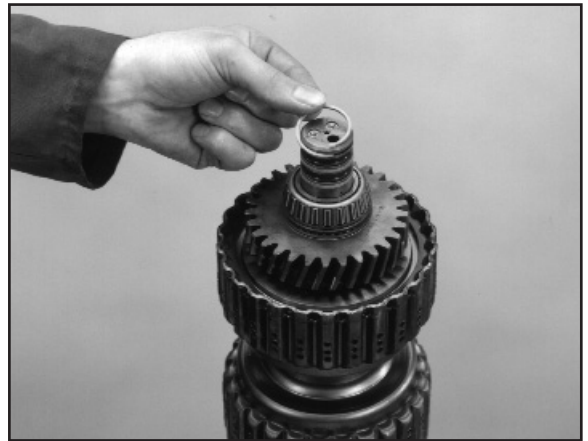

2.25 Finally fit 3 new sealing rings to the rear of the shaft as shown.
(To avoid damage the sealing rings should be left off until all shimming operations have been completed.)



2:23 Using an appropriately sized tube replace the bearing as shown.

RE-ASSEMBLY OF THE INPUT SHAFT

Note :- On some transmissions the input shaft has a Co-axial pump drive shaft which runs through the centre of the input shaft assembly. The strip and rebuild procedure for this type of assembly is almost identical .

The following differences should however be noted :-



2:28 There is a pump drive shaft bush fitted in the end of the shaft which may be replaced if worn.

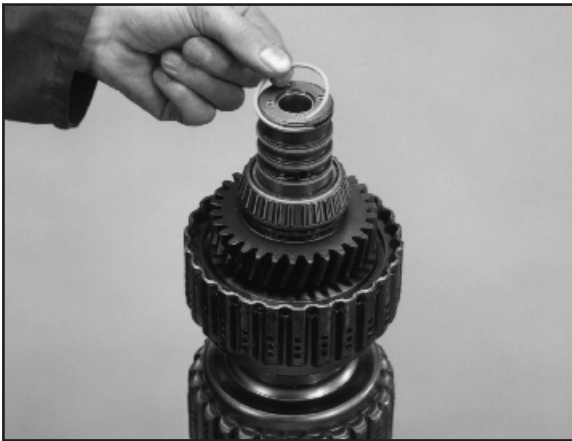

2:26 There are 4 rear sealing rings on the Co-axial input shaft assembly.

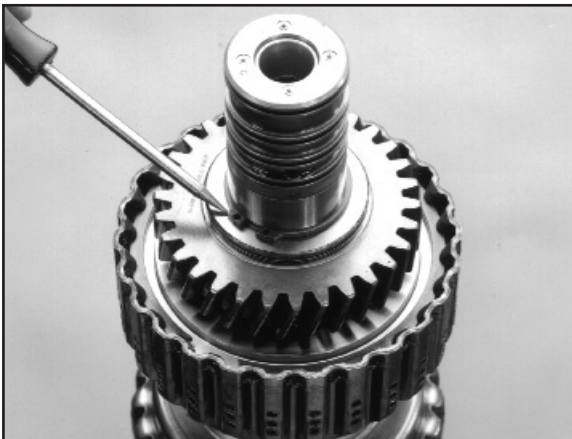

2:27 There is an additional circlip fitted underneath the rear input shaft bearing.

The special tools required are also different. The input shaft spring compressor is No. KM3523 and the front and rear brg. removal collets are Nos. KM3516 and KM3519.

DISASSEMBLY AND RE-ASSEMBLY OF THE COUNTERSHAFT

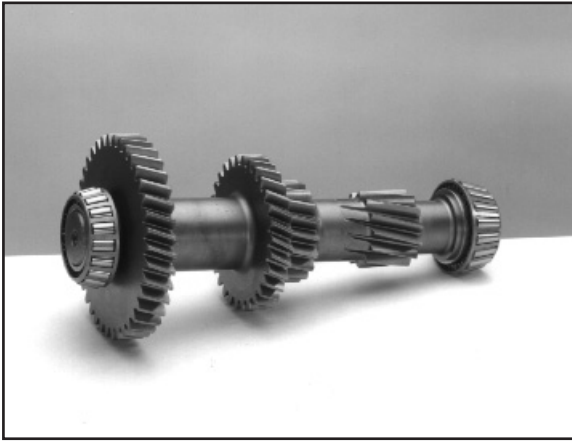

3:1 The countershaft assembly.

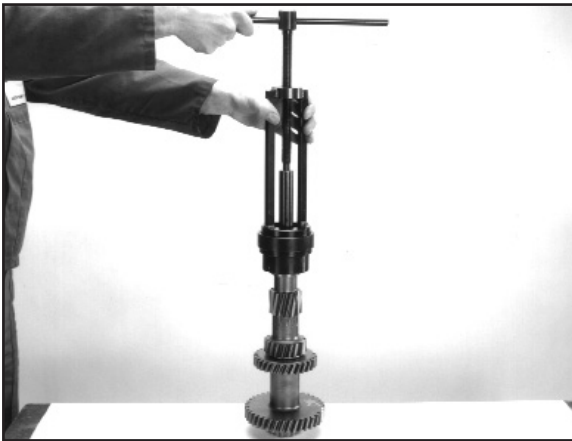

3:2 Using the appropriate bearing pullers remove the countershaft front and rear bearings.
(Tool Nos.KM3522 and KM3518).



3:3 Using an appropriately sized tube replace the countershaft front and rear bearings.

DISASSEMBLY AND RE-ASSEMBLY OF THE REVERSE IDLER SHAFT

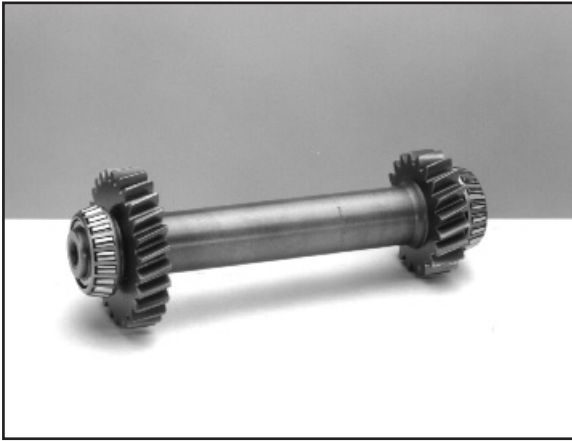

4:1 The reverse idler assembly.

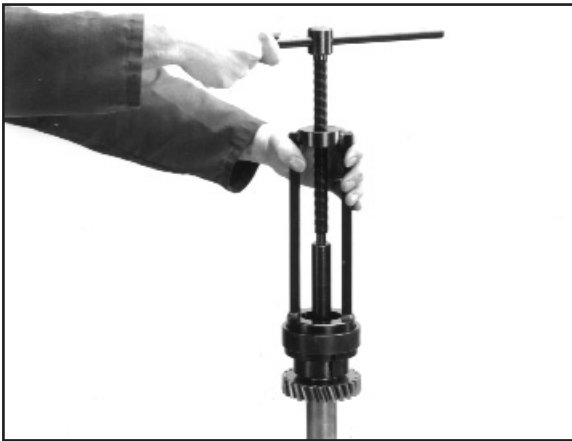

4:2 Using the appropriate bearing puller remove the front and rear bearings.
(Tool No.KM3509)



4:3 Using an appropriately sized tube replace the front and rear bearings.

OUTPUT SHAFT DISASSEMBLY



5:1 Position the shaft assembly in a soft jawed vice as shown.



5:4 Remove the 3rd / 4th synchro assembly.



5:2 Using the appropriate bearing puller remove the front bearing. (Tool No.KM3517)



5:5 Remove the circlip and synchro hub.



5:3 Remove the thrust washer and 4th gear.



5:6 Remove the 3rd gear.

OUTPUT SHAFT DISASSEMBLY

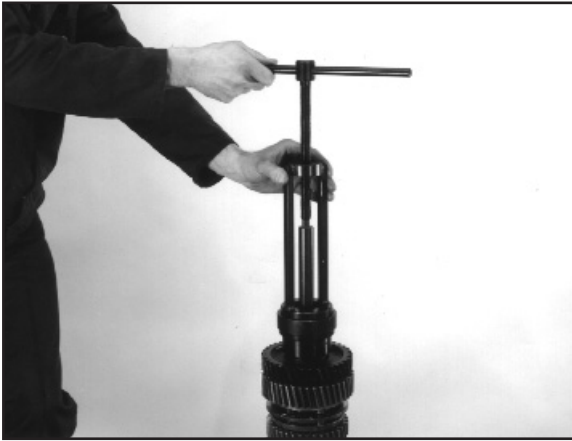

5:7 Invert the shaft and using the appropriate bearing puller remove the rear bearing.
(Tool No.KM3518)



5:10 Remove the needle bearings and spacer.

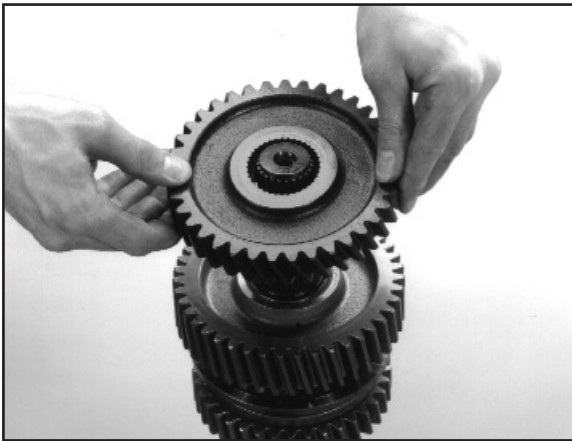

5:8 Remove the 4 wheel drive gear.
(On 2 wheel drive models a spacer is fitted in place of a gear.)

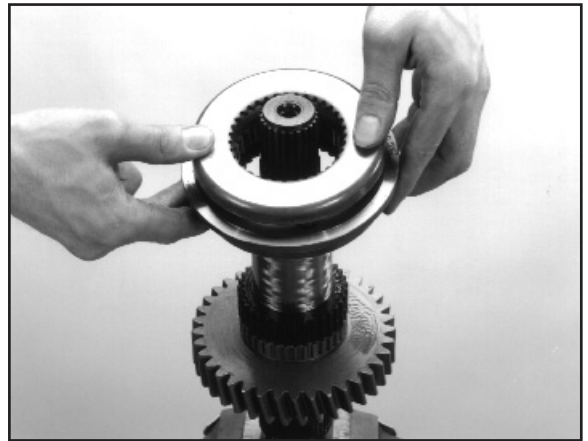

5:11 Remove the 1st / 2nd synchroniser assembly.



5:9 Remove the 1st gear.



5:12 Using a suitable bearing puller or press. Remove the bearing sleeve , synchro hub and 2nd gear.

OUTPUT SHAFT DISASSEMBLY



5:13 Remove the bearing sleeve, synchro hub and 2nd gear.

OUTPUT SHAFT RE-ASSEMBLY

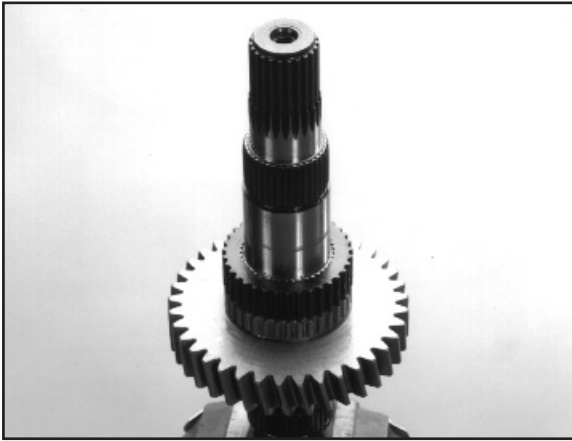

5:14 Replace the 2nd gear and synchro hub.

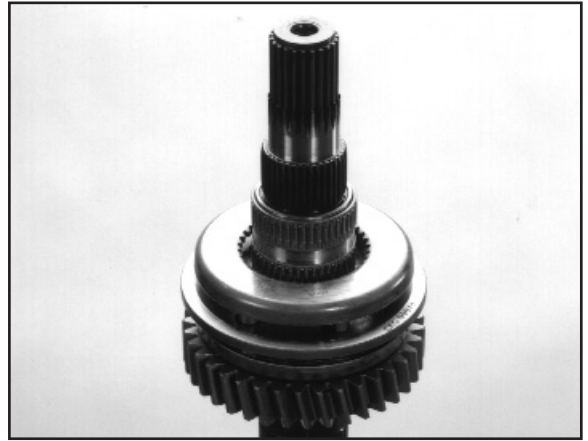

5:17 Replace the 1st gear needle bearings and spacer as shown.

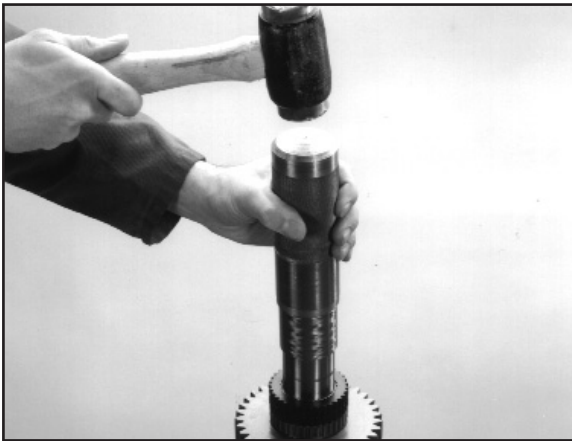

5:15 Using an appropriately sized tube refit the 1st gear bearing sleeve.



5:18 Replace the 1st gear.



5:16 Replace the 1st / 2nd synchroniser assembly.



5:19 Replace the 4 wheel drive gear using Loctite 649 spline lock or equivalent.

Note: the gear should be fitted with the fluted boss against the 1st gear. (On 2 wheel drive models a spacer is fitted in place of the gear.)

OUTPUT SHAFT RE-ASSEMBLY



5:20 Using an appropriately sized tube refit the rear bearing.

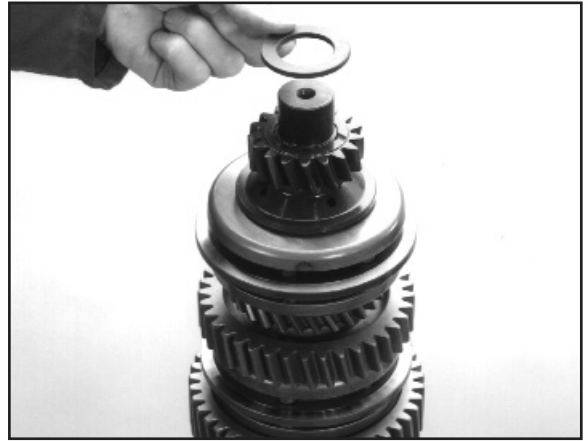

5:23 Refit the 4th gear and thrust washer as shown.

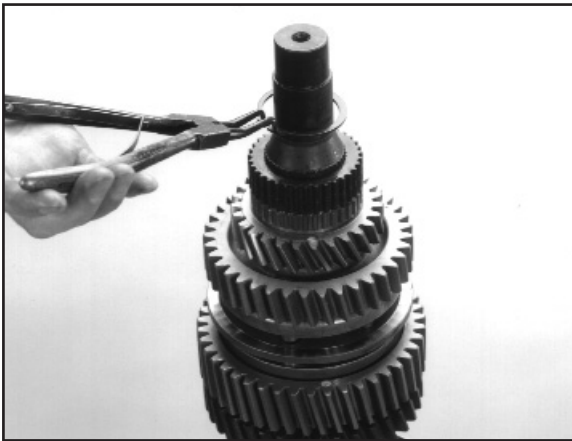

5:21 Invert the shaft and refit the 3rd gear, synchro hub and circlip.



5:24 Using an appropriately sized tube replace the front bearing.

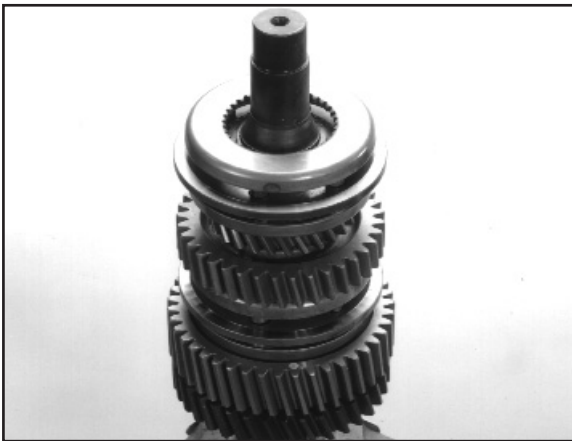

5:22 Refit the 3rd / 4th synchroniser assembly.

HYDRAULIC DOG CLUTCH 4 WHEEL DRIVE DISASSEMBLY



6:1 The hydraulic dog clutch 4 wheel drive assembly.



6:4 Remove the thrust washer.



6:2 Position the shaft in a soft jawed vice and remove the sealing ring.



6:5 Remove the 4 wheel drive gear.

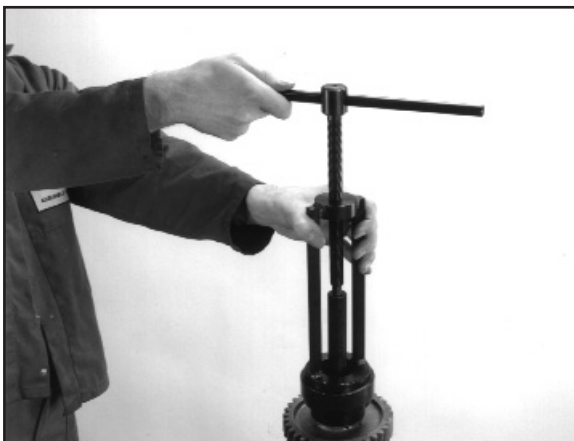

6:3 Using the appropriate bearing puller remove the rear bearing. (Tool No.KM3516)



6:6 Remove the two needle bearings and spacer.

HYDRAULIC DOG CLUTCH 4 WHEEL DRIVE DISASSEMBLY

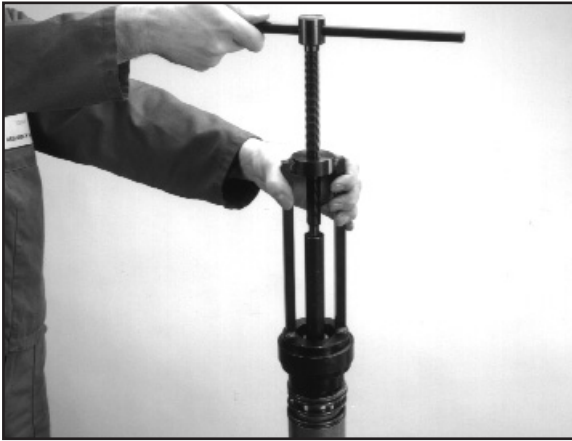

6:7 Invert the shaft and using the appropriate bearing puller remove the front bearing.
(Tool No.KM3516)



6:10 Remove the piston drum assembly.

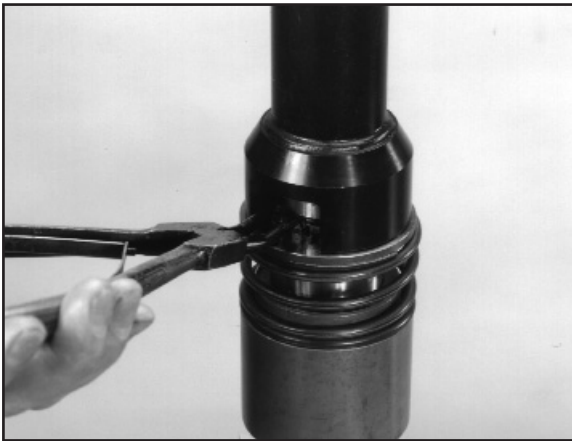

6:8 Using the appropriate tool compress the spring and release the circlip.
(Tool No.KM3523)



6:11 Remove the piston seal and O ring from the shaft and discard.



6:9 Remove the circlip, retainer, and spring.



6:12 Remove and discard the piston seal and O ring from the piston drum .

RE-ASSEMBLY

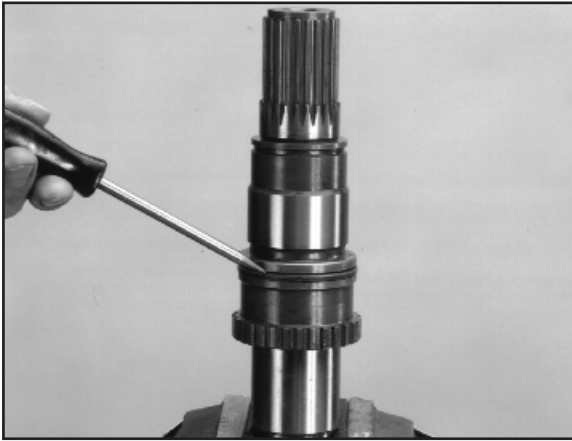

6:13 Fit a new O ring and sealing ring to the shaft.



6:16 Replace the piston spring and retainer.



6:14 Fit a new O ring and sealing ring into the piston. Bend the sealing ring into a heart shape as shown to assist assembly.



6:17 Using the appropriate tool compress the spring and retainer and refit the circlip. (Tool No.KM3523)

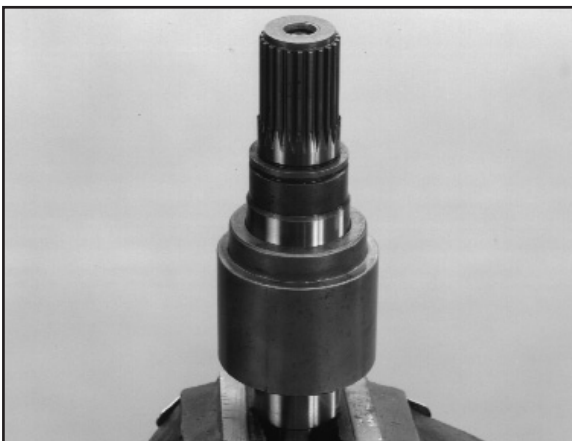

6:15 Lubricate the seals with a light grease and refit the piston to the shaft.



6:18 Using an appropriately sized tube refit the front bearing.

RE-ASSEMBLY.



6:19 Invert the shaft and refit the two needle bearings and spacer as shown.



6:22 Using an appropriately sized tube replace the rear bearing.



6:20 Replace the 4 wheel drive gear.

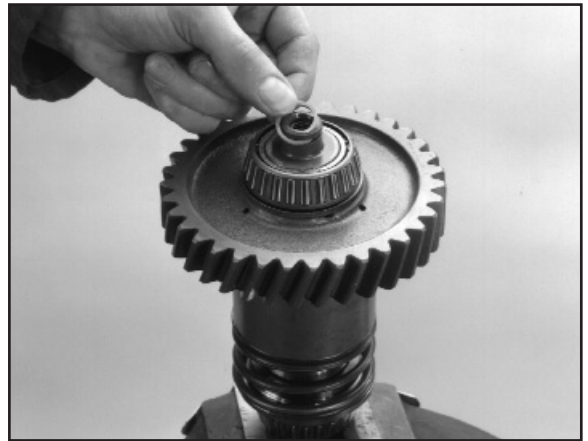

6:23 Fit a new sealing ring. (To avoid damage the sealing ring should be left off until all shimming operations have been completed.)



6:21 Replace the thrust washer.

PERMANENT 4 WHEEL DRIVE SHAFT DISASSEMBLY



7:1 The permanent 4 wheel drive shaft.

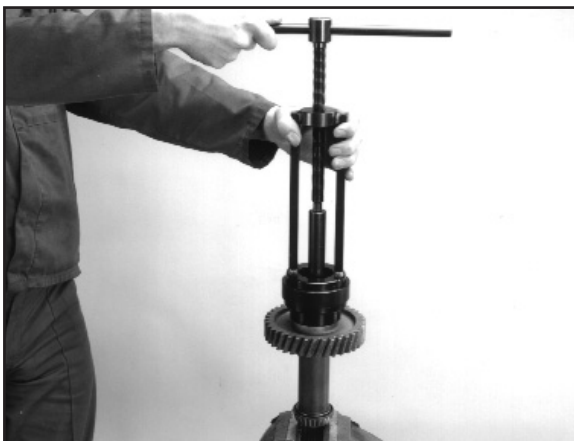

7:2 Using the appropriate bearing puller
remove the front and rear bearings.
(Tool No.KM3516)



7:3 Remove the 4 wheel drive gear.

RE-ASSEMBLY



- 7:4 Replace the 4 wheel drive gear using Loctite 649, or equivalent, on the shaft splines.
Then using a suitably sized tube re-fit the front and rear bearings.

HYDRAULIC MULTI PLATE CLUTCH 4 WHEEL DRIVE SHAFT DISASSEMBLY



8:1 The hydraulic multi plate clutch 4wd shaft assembly.



8:4 Remove the thrust washer and needle bearing.

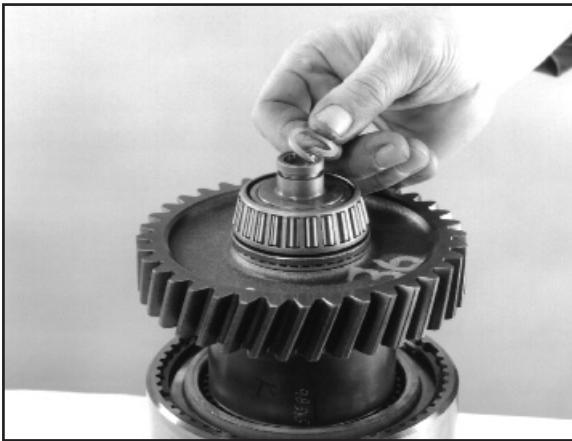

8:2 Mount the shaft assembly in a suitable soft jawed vice and remove the rear sealing ring.



8:5 Remove the 4wd gear.



8:3 Using the appropriate tool remove the rear bearing. (Tool No.KM3516)



8:6 Remove the needle bearings and spacer.

DISASSEMBLY CONTD.



8:7 Remove the needle bearing and thrust washer.

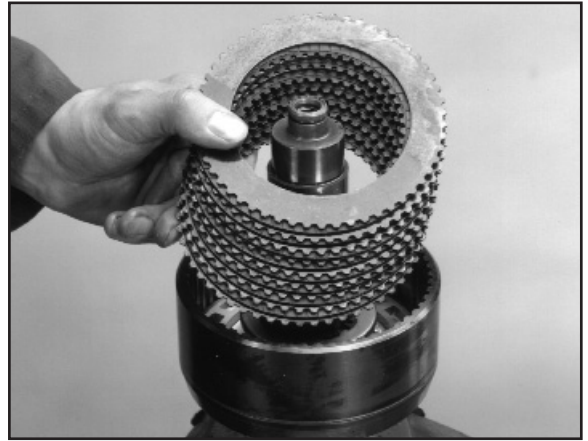

8:10 Remove the clutch pack.



8:8 Remove the clutch pack retaining clip.

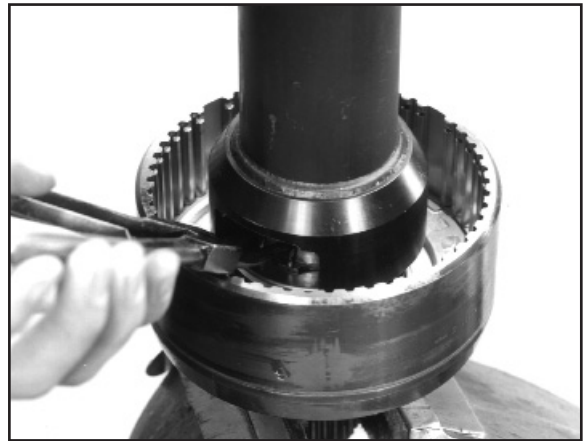

8:11 Using the appropriate tool compress the piston return spring and release the circlip. (Tool No.KM3521)



8:9 Remove the clutch pack retaining plate.



8:12 Remove the clip retainer and spring.

DISASSEMBLY CONTD.



8.13 Remove the piston from the drum.

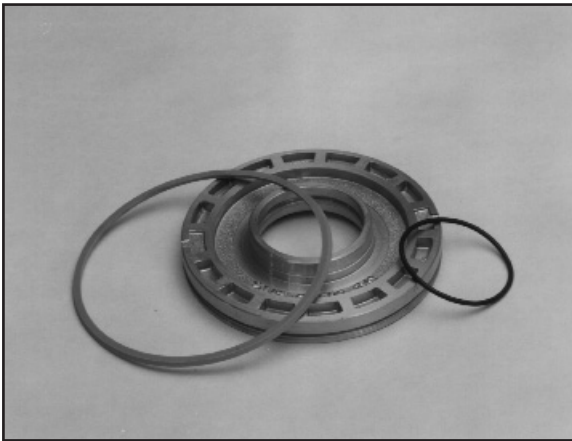

8.14 Remove and discard the piston sealing rings.

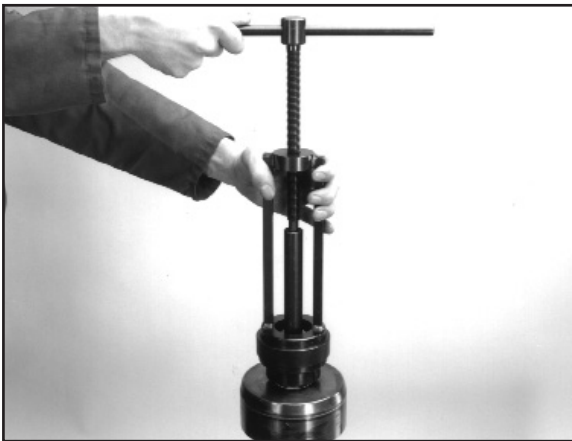

8.15 Invert the shaft and remove the front bearing using the appropriate tool.
(Tool No. KM3516)

RE-ASSEMBLY



8:16 Using an appropriately sized tube re-fit the front bearing.

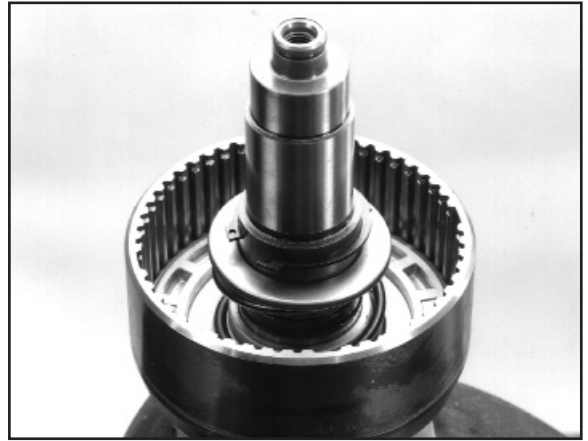

8:19 Lubricate the seals with a light grease and re-fit the piston into the clutch drum. Then replace the spring, retainer and circlip as shown.



8:17 Re-new the piston sealing rings to assist assembly the seals may be warmed in lukewarm water prior to assembly.

Note : the outer seal must be fitted with the open edge facing away from the clutch pack.

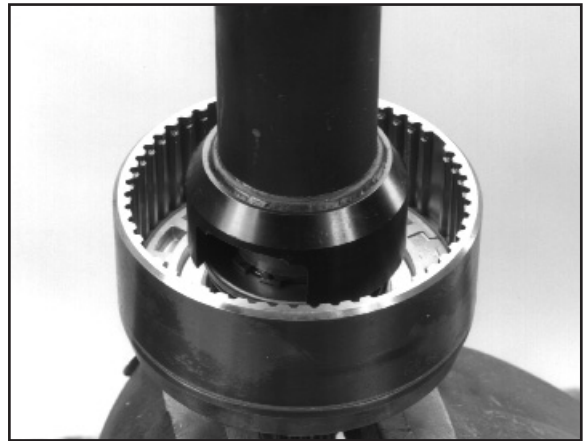

8:20 Using the appropriate tool compress the piston return spring and locate the circlip into its groove. (Tool No.KM3521)



8:18 Using the appropriate tool compress the piston sealing rings. The seals should be left in the tool for a minimum of 30 minutes prior to assembly into the clutch drum. (Tool No.KM3510)

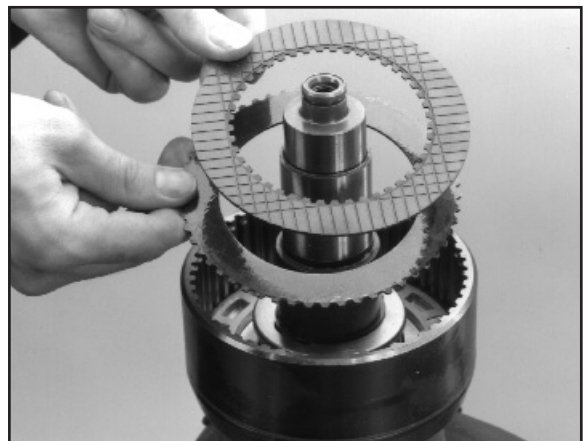

8:21 Replace an externally splined (plain) disc then an internally splined (friction) disc alternately until 8 plain discs and 8 friction discs have been fitted.

RE-ASSEMBLY



8:22 Replace the retaining plate and fit a new retaining clip.



8:25 Refit the needle bearings and spacer.



8:23 Refit the thrust washer and needle bearing.

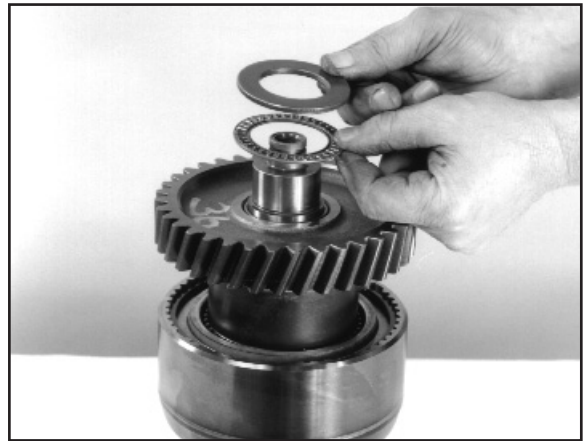

8:26 Refit the needle bearing and thrust washer.



8:24 Refit the 4 wheel drive gear.



8:27 Using an appropriately sized tube re-fit the rear bearing.

RE-ASSEMBLY

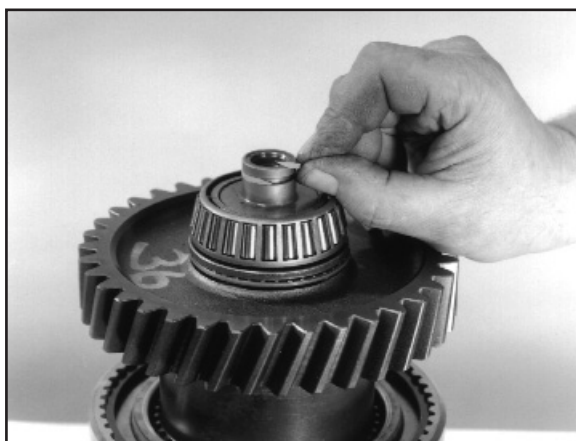

8:28 Refit a new sealing ring and lubricate with a light grease.
(To avoid damage the sealing ring should be left off until all shimming operations have been completed.)

DISASSEMBLY AND RE-ASSEMBLY OF THE OIL PUMP

Note :-

Individual components of the oil pump are non serviceable. The pump may, however, be stripped for cleaning and examination purposes.

Note:- Transmissions fitted with a Co-axial pump drive shaft use a slightly different pump assembly.



9:1 View showing a dismantled pump assembly.



9:3 The two types of pump assembly used. The Co-axial type is on the left.



9:2 The pump oil seal may be replaced using an appropriately sized tube.

DIRECTION CONTROL VALVE

Note :-

Dis-assembly of the control valve is not generally recommended as, with the exception of the solenoids, individual parts are non serviceable. It may however be dismantled for cleaning and examination. The valve fitted may be either the modulated type or the non-modulated type.

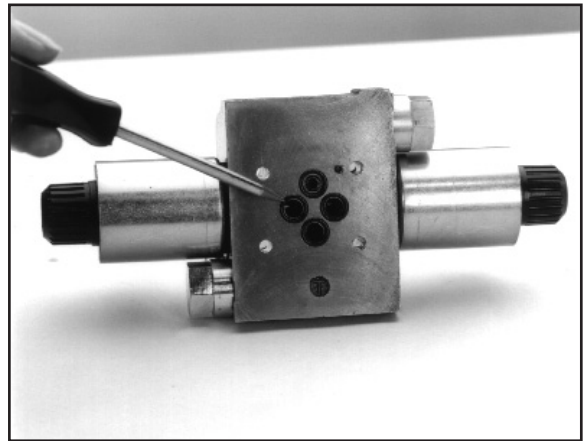

10:3 There are 4 O rings fitted to the underside of the valve which may be renewed if necessary.

The Modulated Valve :-

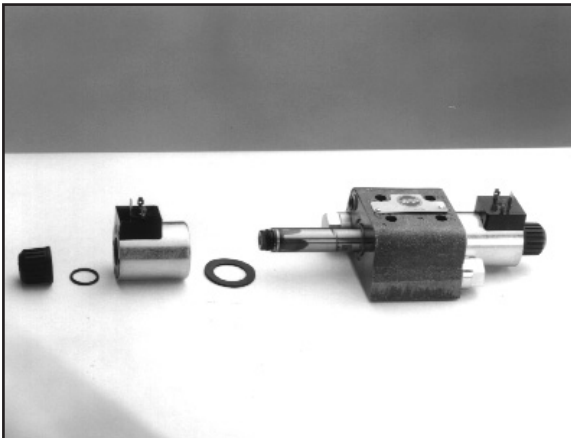

10:1 The retaining nut, coil and washer removed.

The Non-modulated Valve:-

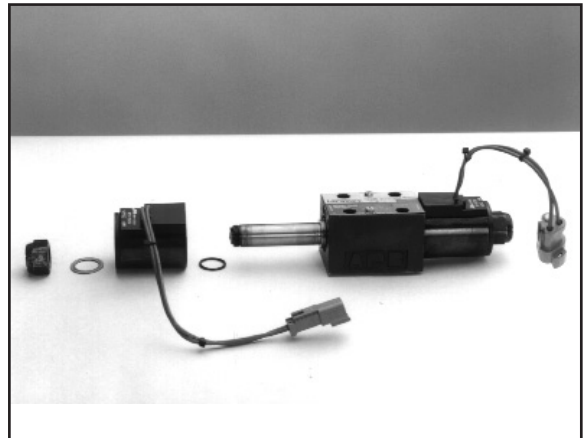

10:4 The retaining nut, coil and washers removed.

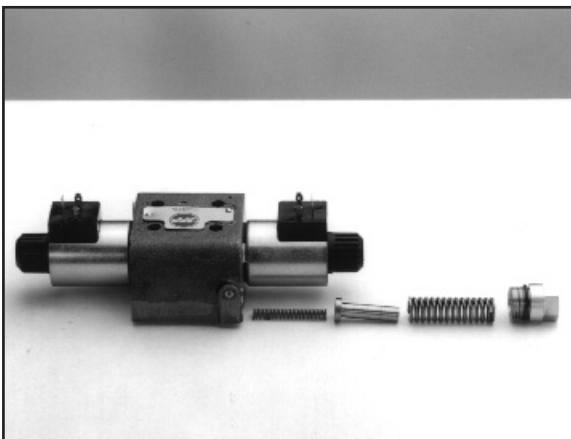

10:2 The modulation components removed.

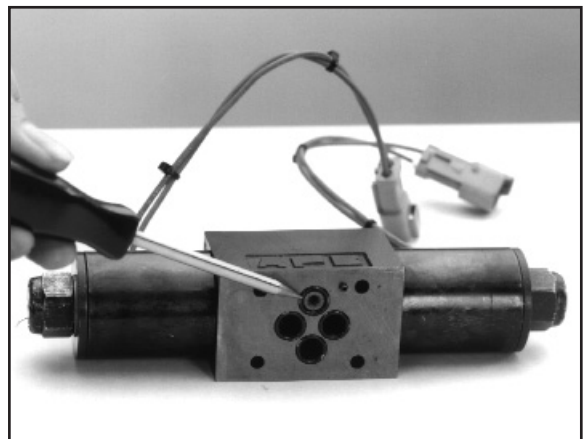

10:5 There are 4 O rings fitted to the underside of the valve which may be renewed if necessary.

GEAR LEVER HOUSING DISASSEMBLY AND RE-ASSEMBLY.



11:1 Remove the plastic ties from the rubber gaiter and pull the assembly apart as shown.

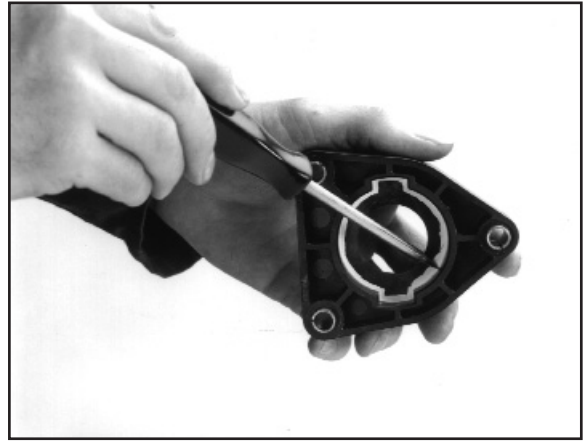

11:2 Apply a bead of RTV joint compound (Loctite 5900) to the sealing face as shown.

Note :-

Before re-assembly remove all traces of old sealant from the joint faces.

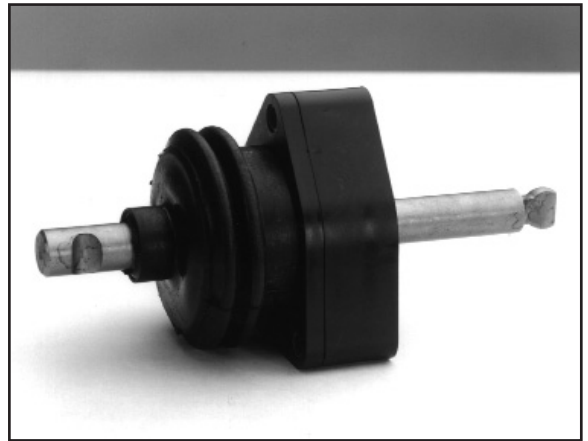

11:3 Lubricate the ball seating with a light grease and push the two halves of the assembly together. Secure the rubber gaiter with two new plastic ties.

TRANSMISSION RE-ASSEMBLY.

General Re-assembly Notes:-

All nylon patch bolts may be re-used 5 to 6 times provided a prevailing thread torque of 15 to 18 lb.in. is recorded.

All shafts and bearings should be lubricated with transmission fluid prior to assembly.

To prevent possible contamination of hydraulic parts lint or cotton rags should not be used.

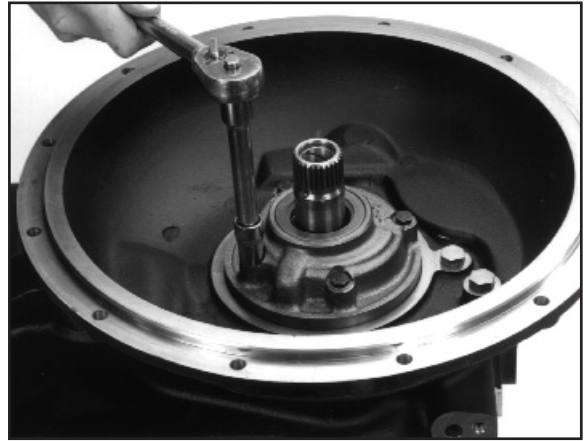

12:3 Refit the oil pump assembly and sealing ring. Tighten 4 bolts to a torque of 13-23 lb.ft. New copper washers must be fitted under the bolt heads. Finally check for free rotation of pump rotor.

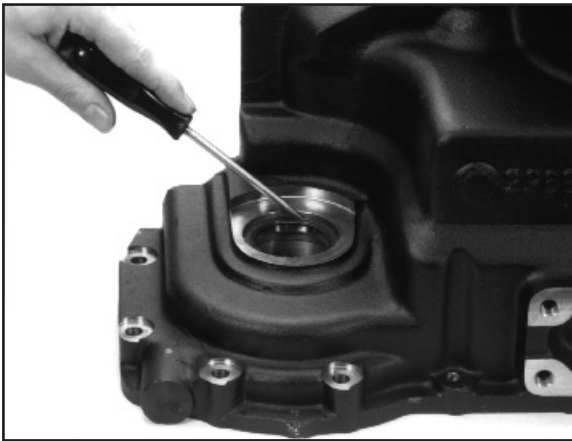

12:1 Position the front case as shown and using a suitably sized tube fit a new 4 wheel drive output shaft oil seal to a depth of 6mm below the housing face. Fill the seal lip with light grease. (Not fitted on 2WD model)

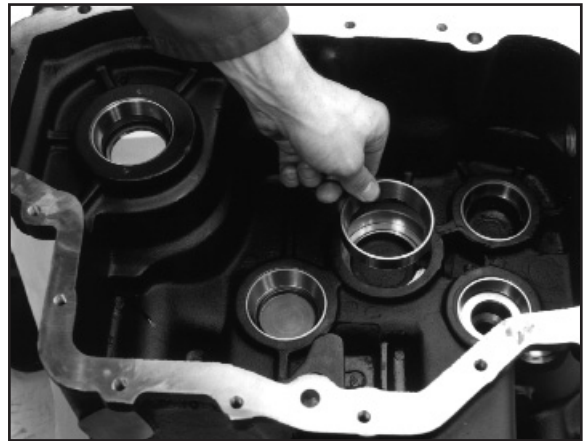

12:4 Invert the case and then re-fit the bearing cups if previously removed.



12:2 If previously removed, replace the two plug and O ring assemblies as shown and tighten to a torque of 30 to 40 lb.ft.



12:5 Using a suitable tool push the inner detent spring and ball into the case and secure in place with a dummy plug as shown.

TRANSMISSION RE-ASSEMBLY CONTD.



12:6 Dummy plug in place.

Note:- Check that the inner detent spring and ball have not become displaced and remove the loose dummy plug from the case sump.

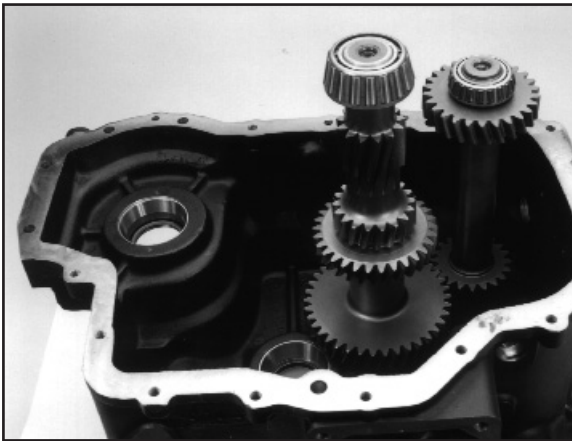

12:7 Replace the countershaft and reverse idler shaft assemblies.

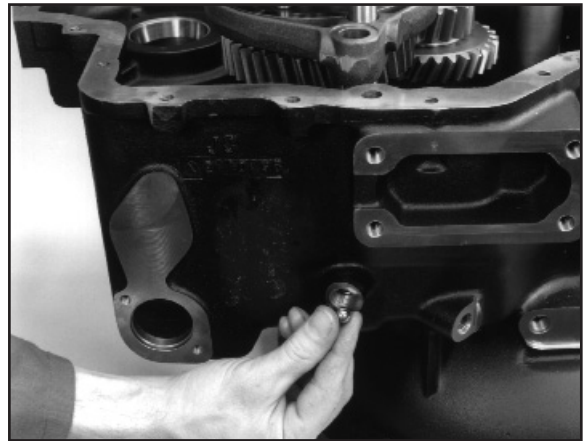

12:9 Push the interlock ball into the detent bore.

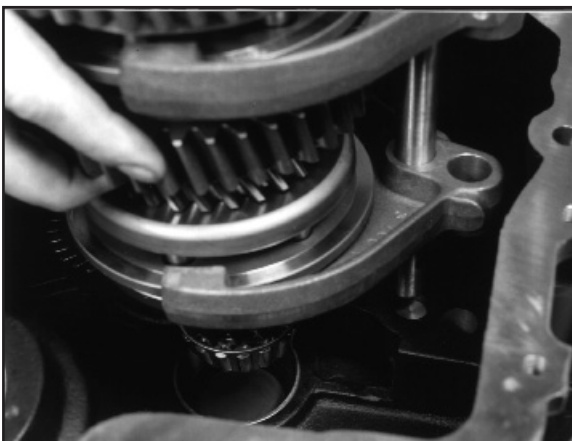

12:8 Slide the 1st / 2nd fork onto the 3rd / 4th rail then refit the 3rd / 4th shift fork and tighten the screw to a torque of 13 to 18 lb.ft. Hold the forks and rail in place on the output shaft then re-fit the complete assembly into the case . The shift rail should displace the dummy plug as it enters the bore.

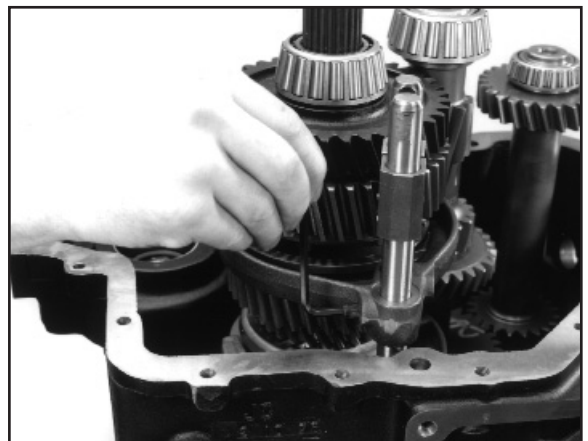

12:10 Refit the 1st /2nd shift rail and tighten the shift fork screw to a torque of 13 to 18 lb.ft. Check that the interlock ball is correctly positioned in between the two rails.

TRANSMISSION RE-ASSEMBLY CONTD.

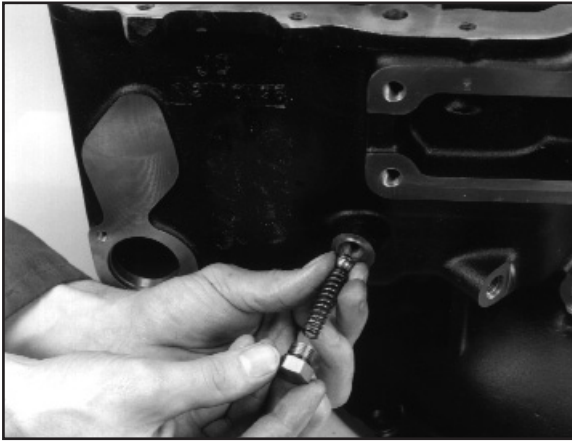

12:11 Replace the outer detent ball and spring.
Tighten the plug to a torque of 30 to 40 lb.ft.



12:14 Rear case with all shaft assemblies fitted.

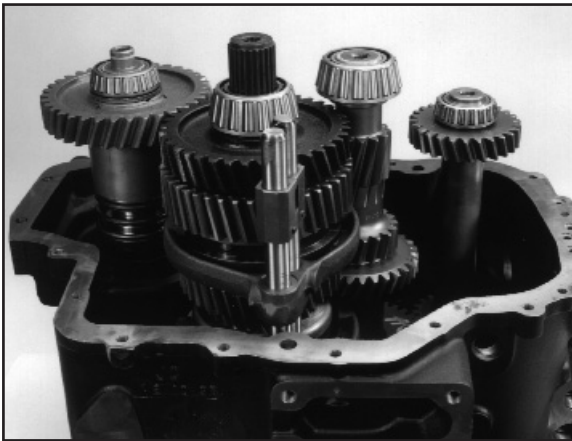

12:12 Replace the 4 wheel drive shaft assembly.
(Not fitted on 2 wheel drive models.)
Lubricate the rear seal with a light grease.

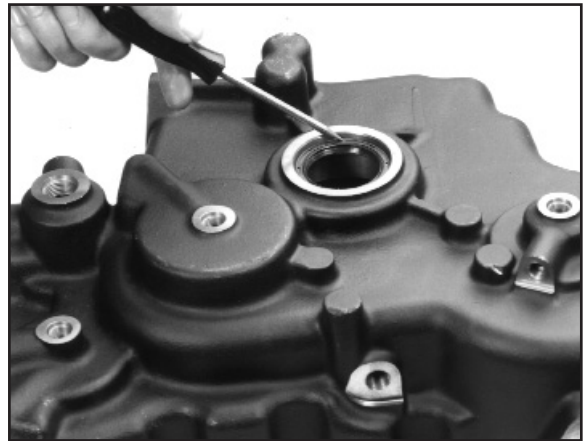

12:15 Position the rear case as shown and using a suitably sized tube fit a new output shaft oil seal to a depth of 6mm below the housing face. Fill the seal lip with a light grease.



12:13 Lubricate the input shaft front and rear seals with a light grease and re-fit the shaft assembly into the case.

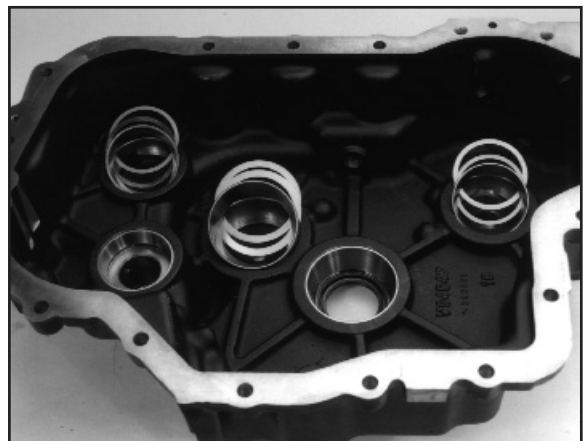

12:16 Invert the case and replace the shim packs and bearing cups. The 2mm thick spacer shim should be fitted into the case first, then fit the remaining shims followed by the bearing cup. A light grease may be used to help hold the cups in the case.

TRANSMISSION RE-ASSEMBLY CONTD.

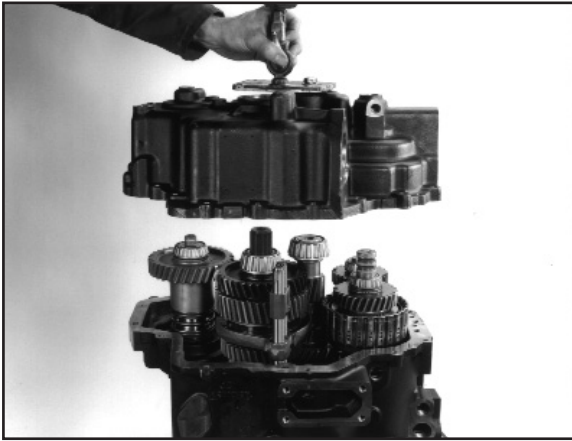

12:17 Re-fit the rear case, (without sealant at this stage), and secure with at least 6 equally spaced bolts. When fitting the rear case be careful to avoid damaging the input shaft sealing rings.

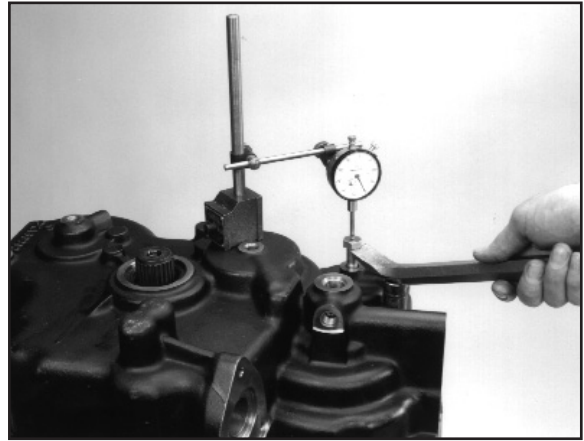

12:19 Attach a suitable shimming tool, (with a 12mm thread), to the end of the reverse idler shaft . Position a D.T.I. as shown, and using a pry bar lift the shaft , then measure and note the end float. (Tool No.KM3524)

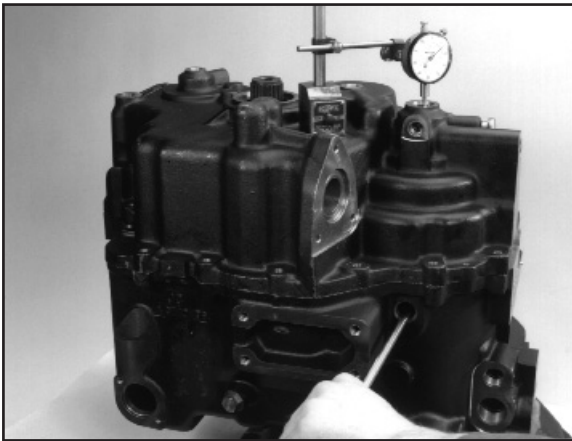

12:18 Position a D.T.I. on the end of the input shaft as shown, and using a suitable pry bar through the side access hole, measure and note the shaft end float.



12:20 Attach a suitable shimming tool, (with a 12mm thread), to the end of the countershaft. Position a D.T.I. as shown, and using a pry bar lift the shaft , then measure and note the end float. (Tool No.KM3524)

Note :-

All shaft assemblies should be rotated several times to seat the bearings prior to measuring the end float.



12:21 Attach a suitable shimming tool, (with a 12mm thread), to the end of the output shaft . Position a D.T.I. as shown , and using a pry bar lift the shaft, then measure and note the end float. (Tool No.KM3524)

TRANSMISSION RE-ASSEMBLY CONTD.

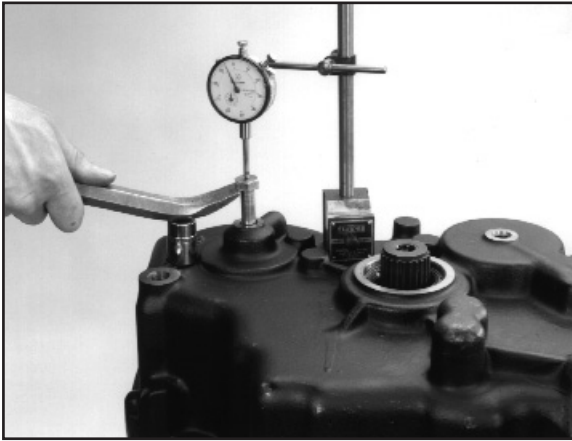

12:22 Attach a suitable shimming tool , (with a 12mm thread) , to the end of the 4 wheel drive shaft . Position a D.T.I. as shown, and using a pry bar lift the shaft, then measure and note the end float. (Tool No.KM3524). Not fitted on 2 wheel drive model.

Remove the rear case and add or remove shims as necessary to give .001" to .003" inches end float on all shafts

Repeat steps 12:17 to 12:22 until all shaft end floats are correct.



12:24 Refit the rear case using an approved liquid gasket (Loctite 5203) taking care not to damage the input shaft or 4WD shaft sealing rings. Tighten the 17 bolts to a torque of 33 to 47 lb.ft.

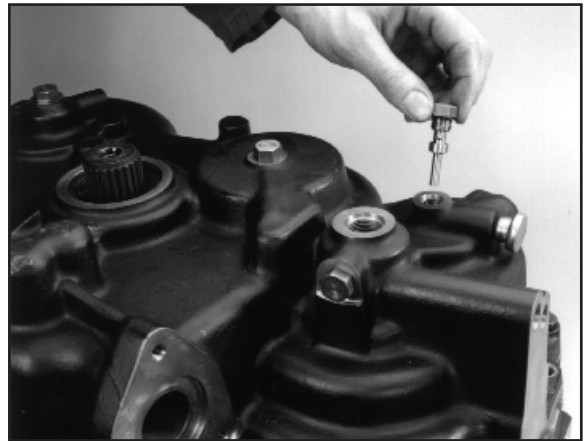

12:25 Replace the shaft end plug and O ring assemblies. Note the special breather plug is fitted in the reverse idler position. Tighten to a torque of 30 to 40 lb.ft.

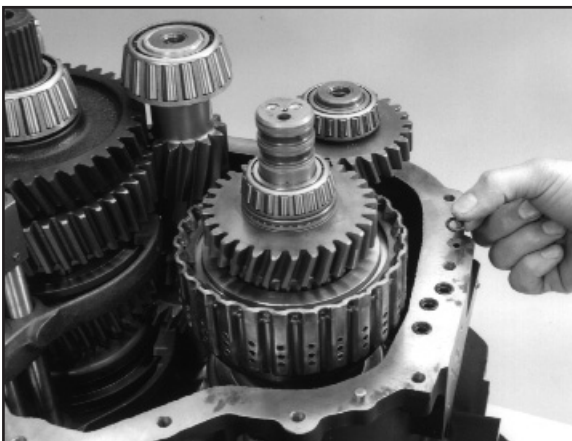

12:23. Replace the 4 O rings in the front case. (There are only 3 fitted on the 2 wheel drive model.)

Note :- The input shaft and 4wd shaft sealing rings should now be fitted.

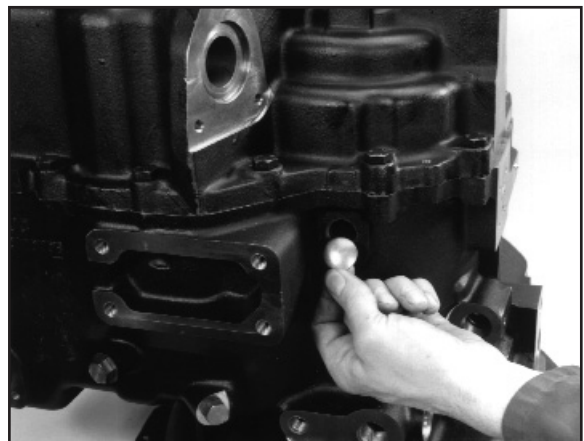

12:26 Fit a new expansion plug to the shimming access hole using an approved sealant. (Loctite 649) .

TRANSMISSION RE-ASSEMBLY CONTD.

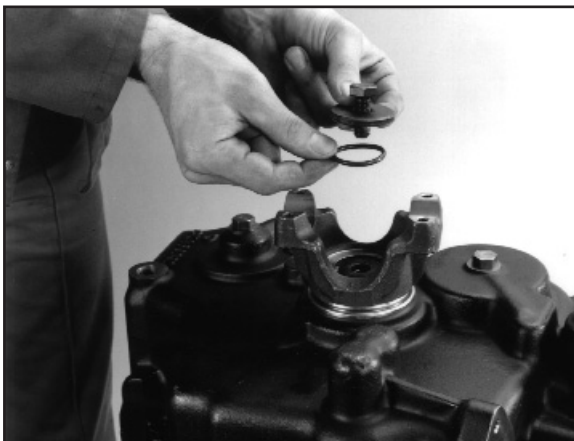

12:27 Replace the output yoke, O ring, washer and bolt. Then tighten to a torque of 50 to 65 lb.ft.



12:30 Lubricate the seals with transmission fluid then re-fit the pressure regulator valve and tighten to a torque of 34 to 44 lb.ft.



12:28 Replace the spacer, 4WD yoke, O ring, washer and bolt. Then tighten to a torque of 50 to 65 lb.ft.



12:31 Lubricate the seals with transmission fluid then re-fit the converter regulator valve and tighten to a torque of 17 to 22 lb.ft.

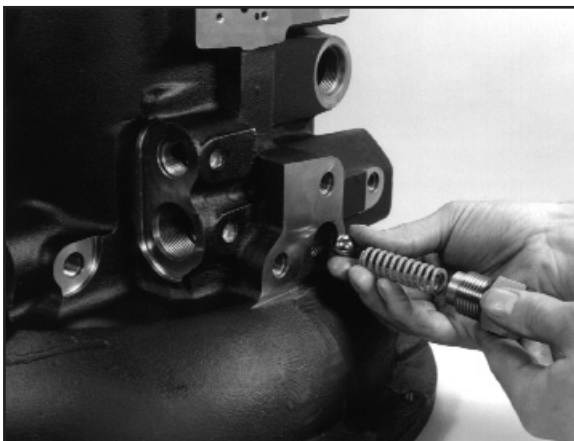

12:29 Refit the cold start ball, spring and housing. Then tighten to a torque of 34 to 44 lb.ft.

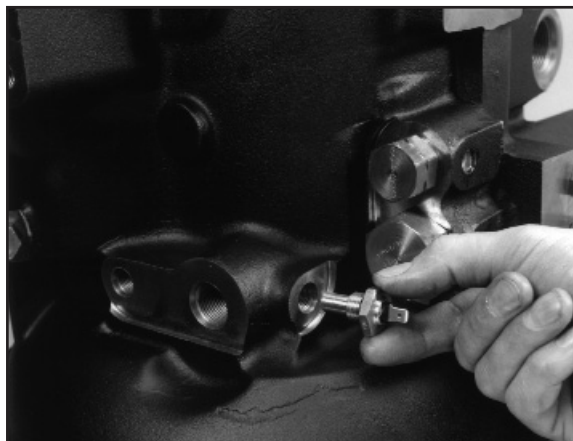

12:32 Refit the temperature sender and tighten to a torque of 15 to 20 lb.ft.

TRANSMISSION RE-ASSEMBLY CONTD.

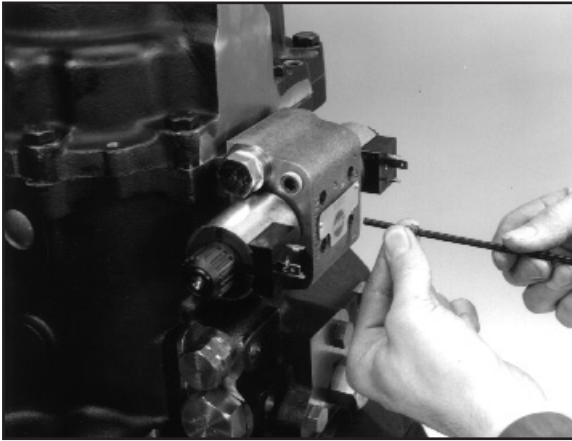

12:33 Ensure the 4 O rings are in place then re-fit the control valve assembly, tighten the 4 cap screws to a torque of 5.0 to 6.3 lb.ft. Re-fit the 4 plastic caps to the capscrew holes.

Note:- The valve can only be fitted one way round as it is located by a small dowel pin.

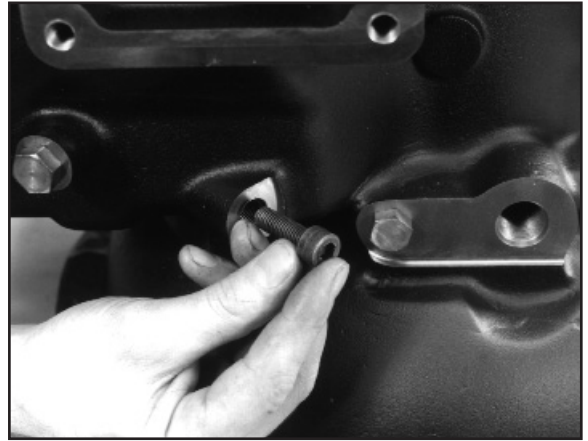

12:36 Refit the 4th gear lock out screw, (when this feature is not required a shorter blanking screw is fitted.) On some applications an additional sealing plug may be fitted.

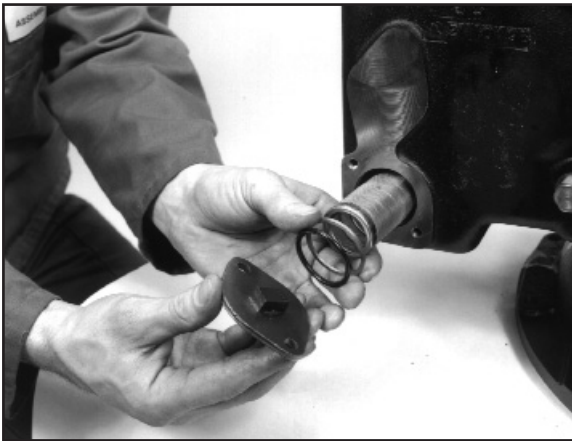

12:34 Refit the strainer, spacer, O ring and cover plate. Then tighten the two screws to a torque of 13 to 23 lb.ft.

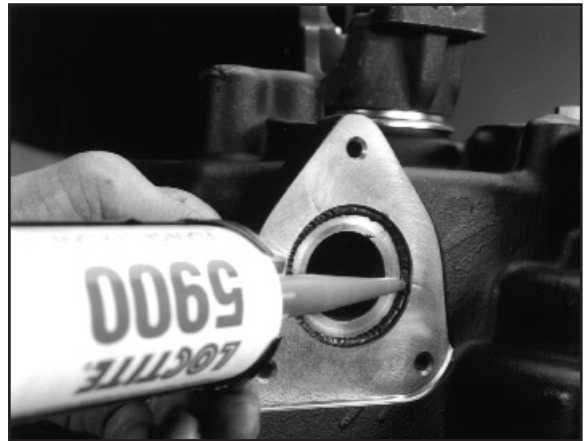

12:37 Apply a bead of RTV joint compound (Loctite 5900) to the gear case as shown.



12:35 Refit the drain plug and O ring assembly. Tighten to a torque of 25 to 40 lb.ft.

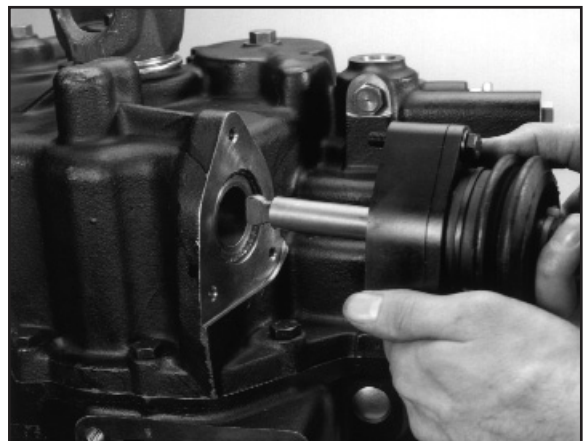

12:38 Refit the gear lever assembly and tighten the three bolts to a torque of 12 to 18 lb.ft.

TRANSMISSION RE-ASSEMBLY CONTD.

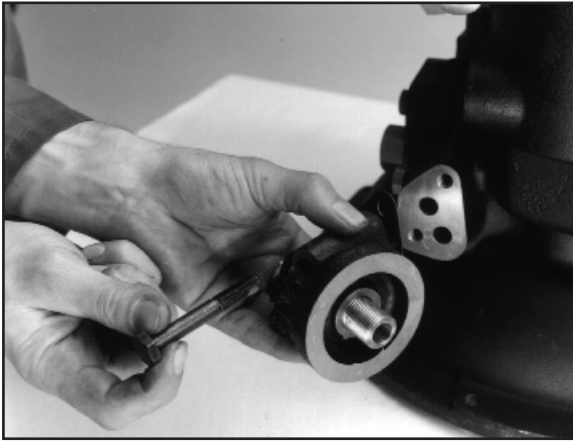

12:39 Refit the filter housing and gasket. Tighten the two bolts to a torque of 33 to 47 lb.ft.

Note:- Do not use sealant on this gasket as it is graphite coated.

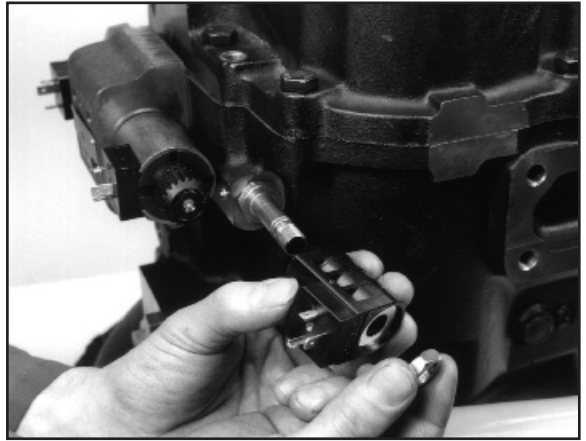

12:42 Refit the 4 wheel drive solenoid coil and nut. Tighten to a torque of 4 lb.ft. maximum. (Not fitted on 2 wheel drive model.)

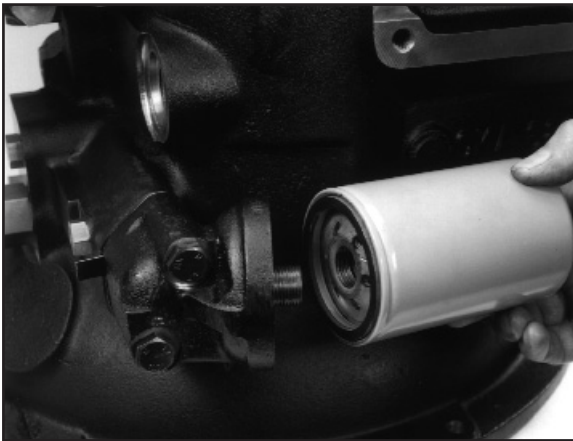

12:40 Lubricate the seal with a light grease and screw on a new oil filter. Tighten to a torque of 7 to 10NM, or a half to three quarters of a turn after initial seal contact.

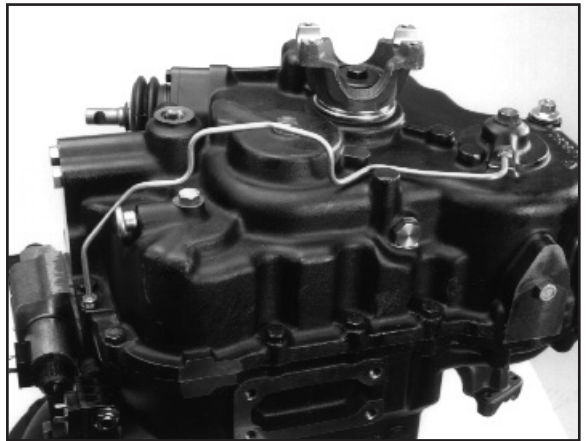

12:43 If previously removed re-fit the 4 wheel drive clutch supply pipe, apply sealant (Loctite 542) to threads and tighten nuts to a torque of 5 to 7.5 lb.ft. (Not fitted on 2 wheel drive model.)

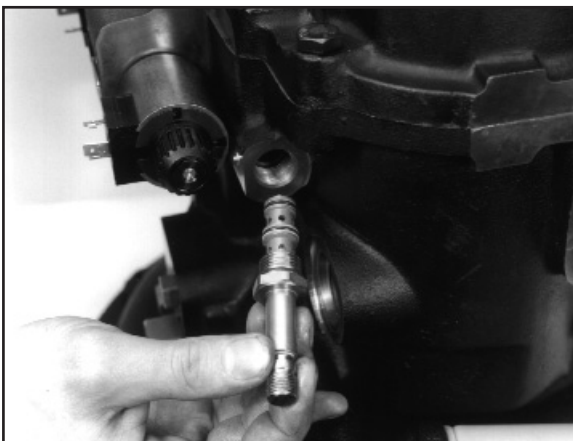

12:41 Lubricate the seals with a light grease and re-fit the 4 wheel drive solenoid spool. Tighten to a torque of 15 to 20 lb.ft. (Not fitted on 2 wheel drive model.)

TEST PORTS

Test Notes:-

The transmission oil, should be at an approximate temperature of 80 °C during pressure tests.

All test ports have a 9/16" UNF thread.

Forward, Reverse and 4wd Clutch pack pressures should not be more than 1 bar lower than the oil pump pressure.

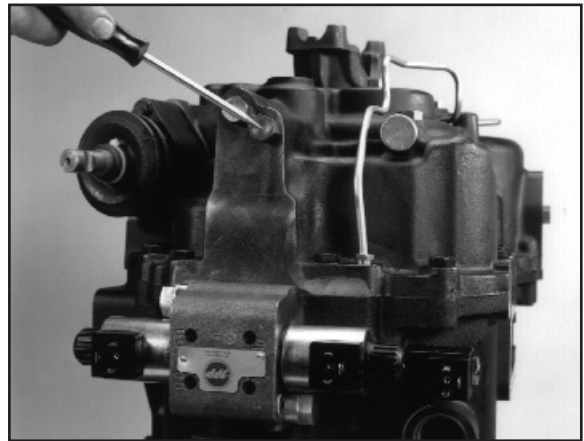

13:3 Forward clutch pressure test point.
Pressure should be 12.5 to 15.5 bar at Maximum engine speed. (Approx. 2500 RPM)

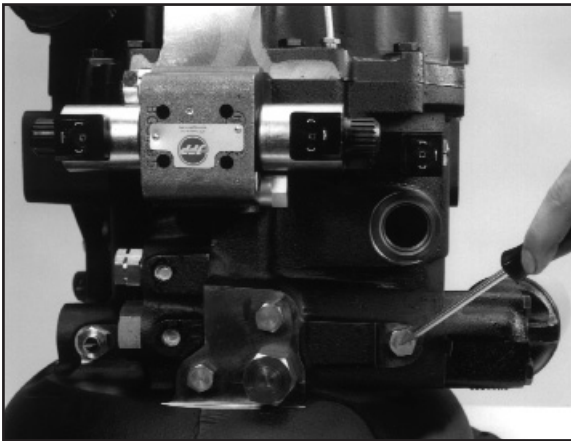

13:1 Oil pump pressure test port. Pressure should be 13.5 to 15.5 bar at Maximum engine speed. (Approx. 2500 RPM)

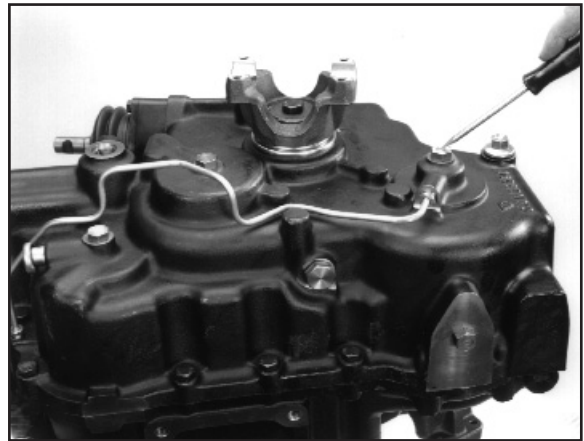

13:4 Four wheel drive pressure test point.
Pressure should be 12.5 to 15.5 bar at Maximum engine speed. (Approx. 2500 RPM)

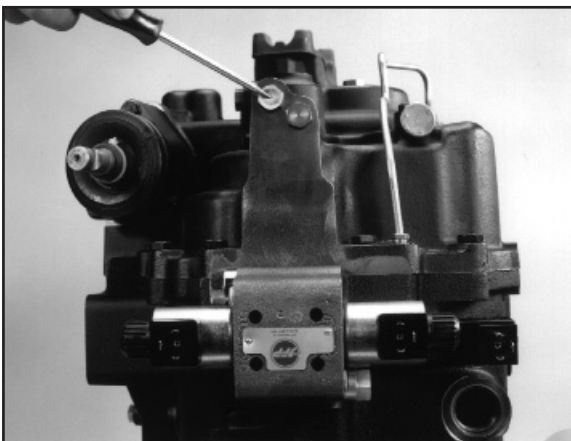

13:2 Reverse clutch pressure test point.
Pressure should be 12.5 to 15.5 bar at Maximum engine speed. (Approx. 2500 RPM)

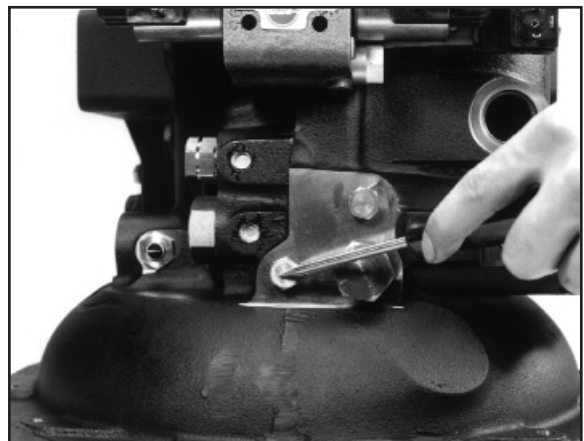

13:5 Converter relief pressure test point.
Pressure should not exceed 7.5 bar at maximum engine speed. (Approx 2500RPM)
For Co-Axial Transmissions max pressure should be 10.5 bar.

TEST PORTS CONTD.

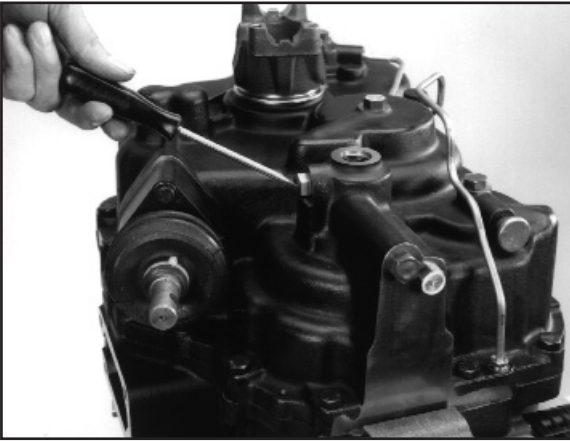

- 13.6 Lubrication pressure test point. Pressure should be 0.5 to 2.5 bar at Maximum engine speed. (Approx. 2500 RPM).

PARKING BRAKE

Some transmissions are fitted with a mechanical calliper parking brake.

The calliper assembly is mounted directly onto the rear face of the transmission housing.

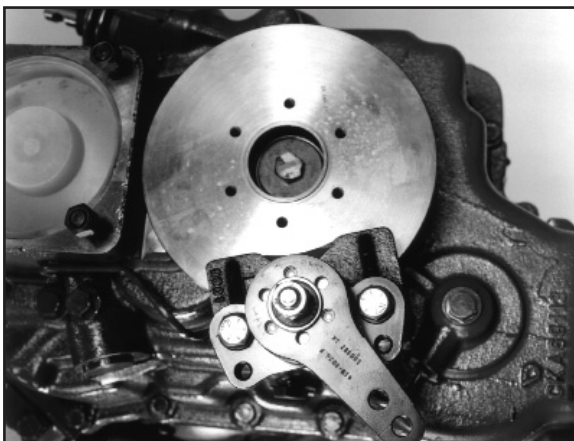

14:1 Transmission fitted with a parking brake.
Refer to next page for installation and adjustment.

PARKING BRAKE INSTALLATION AND ADJUSTMENT

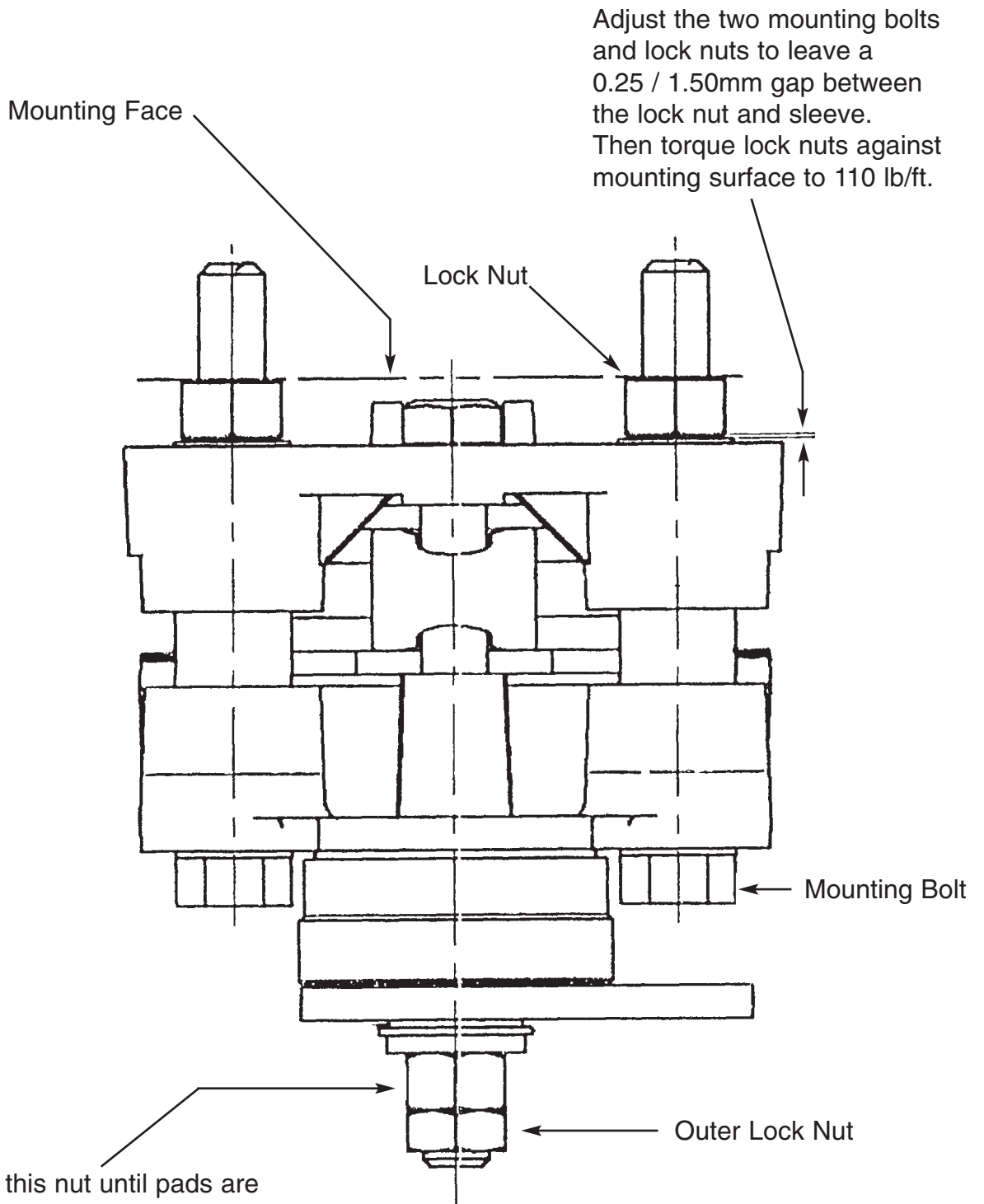

Adjust this nut until pads are in contact with the brake disc. Then back off 4 to 5 flats. Finally torque outer lock nut to 45 - 55 lb/ft.

REPLACING THE FRICTION PADS

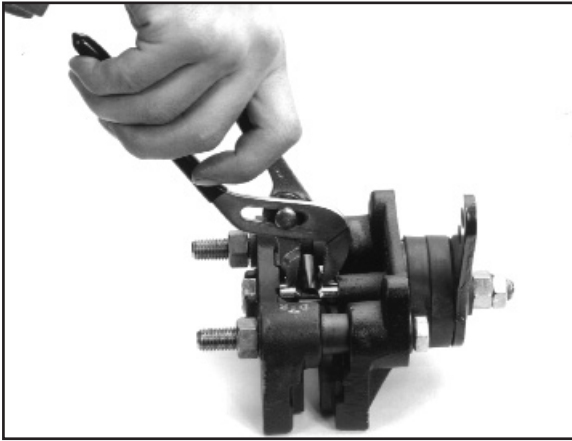

14:2 Remove the retaining spring clip.

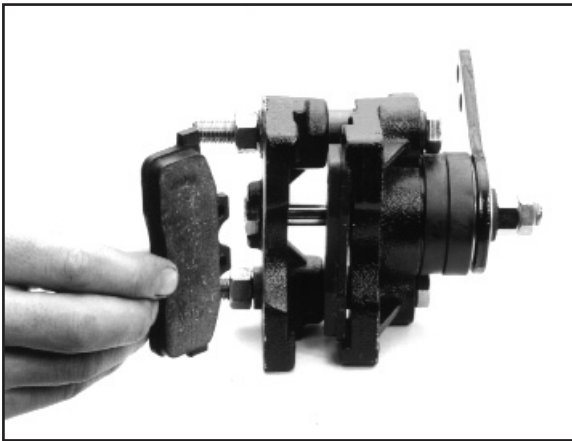

14.3 Withdraw the friction pads.

Fit the new pads with the friction faces inboard and refit the retaining spring clip.

COMPACT PLUS TEST PROCEDURE

If a malfunction of the transmission is indicated a systematic pressure checking procedure should be followed. These checks should be carried out while the transmission is still in the vehicle so that true operating conditions are created. Pressure checks are essential since a failure in the hydraulic system may not be easily traceable when the transmission is stripped down on a bench.

All pressure checks should be carried out with the transmission gear lever in the neutral position, the oil temperature at 80 to 85 deg. C. and the engine speed maintained at 2000 to 2500 RPM. As a safety precaution the vehicles parking brake should be applied.

All pressure test ports have a 9/16 ins. UNF thread. A pressure gauge is required that will measure up to 20 bar (290 lb / in²).

For test port locations refer to illustrations 13:1 to 13:6.

FAULT DIAGNOSIS HYDRAULIC SYSTEM

FAULT	POSSIBLE CAUSES
Transmission fails to drive in either direction	Low or no pump pressure Low or no oil in transmission. Mechanical failure in transmission. Worn or broken input shaft sealing rings. Pressure regulator valve faulty. Direction control valve not operating. Blockage in oil ports restricting flow.
Transmission drives in one direction only.	Low oil pressure on one clutch pack due to leaks. Clutch piston seals worn or damaged. Clutch pack excessively worn. Direction valve or coil faulty. Mechanical failure in transmission. Blockage in oil ports restricting flow. Worn or damaged input shaft sealing ring.
Delay in taking up drive.	Low converter pressure. Low oil level. Low clutch pressure. Faulty modulation in direction control valve. Blockage in direction valve. Blockage in oil ports restricting flow.

FAULT DIAGNOSIS HYDRAULIC SYSTEM. CONTD.

FAULT	POSSIBLE CAUSES
No drive from 4wd.	4wd solenoid valve or coil not operating. Mechanical failure in transmission. Low 4wd clutch pack pressure. 4wd clutch pack worn.
Transmission overheating.	Oil level too high or low. Restriction in cooler flow. Low oil pressure. Clutch packs slipping due to low pressure or wear. Mechanical failure in transmission. Excessive stall operation.
Difficult gear selection.	Fwd or Rev. clutch pack pressurised when not selected. Direction valve faulty. Input shaft sealing rings leaking. Mechanical failure in transmission. Fwd or Rev. clutch pack not releasing due to mechanical failure.
Vehicle moves with direction valve in neutral position.	See " Difficult gear selection."
High stall speed	Low oil level. Air in oil. Clutch plates slipping due to low pressure or wear. Torque converter faulty. Converter relief valve faulty. Incorrect torque converter fitted.
Low stall speed.	Poor engine performance. Torque converter defective. Incorrect torque converter fitted.
Low Pump Pressure.	Worn or broken pump. Leaking pump sealing ring. Blocked oil strainer or filter. Blockage in oil ports between transmission sump and oil pump. Pressure regulator valve stuck open. Cold start valve stuck open.
High pump pressure.	Pressure regulator valve faulty. Has normal operating oil temperature been reached?
Low forward or reverse clutch pack pressure.	Faulty direction control valve. Piston seal or O ring leaking. Input shaft sealing ring leaking.
High forward / reverse clutch pack pressure.	Pressure regulator valve faulty.
Converter pressure low.	Converter relief valve faulty. Leak in converter , oil cooler or connecting hoses. Very hot oil.

FAULT DIAGNOSIS HYDRAULIC SYSTEM. CONTD.

FAULT	POSSIBLE CAUSES
Converter pressure high.	Converter relief valve faulty. Blockage or restriction in oil cooler. Very cold oil
Low 4wd clutch pack pressure.	4wd piston seals leaking. 4wd shaft sealing ring leaking. Leak from 4wd clutch supply pipe. Faulty 4wd solenoid. Blockage or restriction in 4wd clutch supply pipe.
High 4wd clutch pack pressure	Pressure regulator valve faulty.
Low lubrication pressure.	Blockage or restriction in oil cooler. Input shaft front sealing ring leaking. Very hot oil.

FAULT DIAGNOSIS MECHANICAL SYSTEM

FAULT	POSSIBLE CAUSES
Noise	Vehicle Driveline Problem:- Axles, Propshafts, Engine, Engine mounts. Mis-alignment of transmission / engine. Bearings worn or damaged . Gear teeth damaged or broken. Excessive end float of shafts or gears. Clutch plate failure forward, reverse or 4wd. Incorrect grade of oil in transmission. Low oil level. Gear or thrust washer beginning to seize.
Difficult gear selection.	Shift rods worn or bent. Shift forks worn, loose or twisted. Synchroniser assemblies worn or damaged. Clutch pack not releasing due to mechanical fault. Clutch pack not releasing due to hydraulic fault. Gear shift stub lever worn or damaged. Incorrect grade of oil in transmission. Low oil level.
Jumping out of Gear.	Detent springs worn or broken. Synchroniser or gear dog teeth worn or damaged. Synchroniser assemblies worn or damaged. Shift forks worn, loose or twisted. Restriction or wear in gear linkage or stub lever assy. not allowing gears to be fully selected. Excess end float on output shaft assembly or gears.