

# **WINGET**

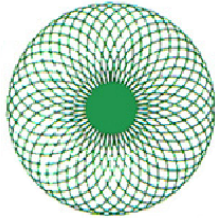

# **Croker**

## **CUMFLOW RP400 ROTATING PAN MIXER**

# **PARTS & OPERATION MANUAL**

**WINGET LIMITED  
PO BOX 41  
EDGEFOLD INDUSTRIAL ESTATE  
PLODDER LANE  
BOLTON  
LANCS  
BL4 OLS  
Tel: ++ 44 (0) 1204 854650  
Fax:++ 44 (0) 1204 854663  
crokersales@winget.co.uk  
parts@winget.co.uk  
www.winget.co.uk**

# **INDEX**

## **SECTION 1      GENERAL INFORMATION**

- 1.1.      Company Details
- 1.2.      Important Notice
- 1.3.      Mixer Operational and Safety Requirements
- 1.4.      Installation Drawing (Where applicable)
- 1.5.      Test Certificates (Where applicable)

## **SECTION 2      INSTALLATION AND OPERATING INSTRUCTIONS**

- 2.1.      Pre Installation Notes
- 2.2.      Installation Instructions
- 2.3.      Operating Instructions

## **SECTION 3      TECHNICAL SPECIFICATION AND MAINTENANCE**

- 3.1.      Technical Specification
- 3.2.      Shutdown Procedure and Maintenance
- 3.3.      Maintenance of Mixer
- 3.4.      Maintenance and Lubrication
- 3.5.      Lubrication Layout

## **SECTION 4      MIXER SPARE PARTS**

- 4.1.      Arrangement of Star and Pan Drive
- 4.2.      Arrangement of Mixing Star and Gearbox
- 4.3.      Arrangement of Mixing Pan
- 4.4.      Arrangement of Mixing Pan Rollers
- 4.5.      Arrangement of Discharge Blade and Control Gear
- 4.3.      Arrangement of Discharge Door
- 4.4.      Arrangement of Discharge Door Pneumatic Cylinder
- 4.5.      Arrangement of Pan Door-Cylinder Linkage
- 4.6.      Arrangement of Fixed Blade
- 4.7.      Arrangement of Forked Blade Option
- 4.8.      Arrangement of Guards
- 4.9.      Drive Chain Oil Lubricator
- 4.10.      Pan Sealing Arrangement
- 4.11.      Decals and Logos

## **SECTION 5      ANCILLIARY EQUIPMENT SPARE PARTS**

- 5.1      Loader Chassis Assembly
- 5.2      Arrangement of Loader, Hopper and Limit Switches
- 5.3      Arrangement of Loader Winch Unit

5.4	Worm Reduction Gearbox
5.5	Magnetic Brake Drum
5.6	Arrangement of Hydraulic Batchweigher
5.7	Arrangement of Lever Type Batchweigher
5.8	Arrangement of Weigh Dial
5.9	Scraper Shovel, Pulleys and Jibs
5.10	Scraper Shovel Winch Unit
5.11	Scraper Shovel Over Run Brake
5.12	Scraper Shovel, Handles and Switch
5.13	N.R. Range Electromagnetic Brake
5.14	A. C. Solenoid Brake
5.15	Electromagnetic Brake
5.16	Wire Rope Renewal Procedure
5.17	Wire Rope Safety Notes
5.18	Arrangement Of Whirler (Where Fitted)
5.19	55 Litre Water Tank
5.20	¾" BSP Water Hydrobot
5.21	0-100 Litre Flowmeter

## SECTION 6      **ELECTRICAL SYSTEM**

6.1	Electrical Instructions
6.2	Wiring Diagrams
6.3	Electrical Component Listing
6.4	Interlock Switch Mounting

## SECTION 7      **PNEUMATIC SYSTEM**

7.1	Pneumatic Instructions – Shutdown Procedure
7.2	Pneumatic Circuit Plastic Push In Fittings
7.3	Air Control Box Early Machines
7.4	Filter/Automatic Drain Valve and Lubricator Early Machines
7.5	Water Tank Pneumatic Controls Early Machines
7.6	Water Tank Pneumatic Air Cylinder

## SECTION 8      **MISCELLANEOUS**

8.1	Noise
8.2	Special Pan Covers & Inlets
8.3	Miscellaneous Items

The contents of this handbook although correct at the time of publication, may be subject to alteration by the manufacturers without notice and Winget Limited can accept no responsibility for any errors or omissions contained within the following pages. Nor can we accept any liability whatsoever arising from the use of this manual howsoever caused.

Winget Limited operate a policy of continuous product development. Therefore, some illustrations or text within this publication may differ from your machine

Winget Limited can accept no responsibility for incorrectly supplied spare parts unless the part number and a full description of the items required is given when the order is placed.

**NOTE**

Imperial fixings (bolts, setscrews, nuts, washers etc) have been progressively changed to Metric. If in doubt as to whether you have a Metric or Imperial fixing please order the metric items listed, i.e. bolt or setscrew and associated flat and spring washers to replace the existing items.

**OPERATING  
AND  
MAINTENANCE MANUAL**

**SECTION 1**

**GENERAL INFORMATION**

**RP400**

## **COMPANY DETAILS AND GENERAL INFORMATION**

For any spares or service work, please contact:-

Winget Limited  
P.O. Box 41  
Edgefold Industrial Estate  
Plodder Lane  
Bolton  
Lancs  
BL4 OLS

Telephone No:	++ 44 (0)1204 854650
Facsimile No:	++ 44 (0)1204 854663
'E Mail'	<a href="mailto:crokersales@winget.co.uk">crokersales@winget.co.uk</a> <a href="mailto:parts@winget.co.uk">parts@winget.co.uk</a>

## **ORDERING SPARES**

To help us to complete your order promptly and correctly we need:-

- Machine type and serial number
- Description and quantity of parts required
- The full address to which the parts are to be sent

Winget Limited can accept no responsibility for incorrectly supplied spare parts unless the part number and a full description of the items required is given when the order is placed.

## **IMPORTANT NOTICE**

The CUMFLOW RP400 is a high performance mixer

The following precautions are necessary to obtain the best results and to avoid damage to the MIXING STAR and DRIVE

**ENSURE TRANSIT BAR AND RING ARE REMOVED FROM DOOR BEFORE STARTING MACHINE.**

### **AGGREGATES**

Strict control of graded aggregates must be maintained

Maximum size 19mm

Oversize lumps of aggregate or rogue materials must be prevented from entering the Pan

### **MIXING STAR BLADES**

They are to a special shape and material to prolong wear life. They should not be modified in any way and only replaced with GENUINE 'CROKER' spares Obtained from **WINGET LIMITED**.

A daily check is advisable to ensure that the Blades/Wearing parts are secure and undamaged.

### **PAN RIM & BASE WEARING PLATES**

They must be replaced before excessive wear causes distortion.

### **MAXIMUM BATCH LOADS**

UNDER NO CIRCUMSTANCES should the Maximum Batch Loads quoted be exceeded nor should the mixer be or re-started when there is a mix in the Pan

### **MIXING PAN**

Ensure that the Mixing Pan is rotating concentrically and that the pan base is Rotating in horizontal place, otherwise damage may occur to the door mechanics.

## WARNING

THE MANUFACTURER ACCEPTS NO RESPONSIBILITY FOR ANY DAMAGE OR FAILURE RESULTING FROM OPERATIONAL MISUSE OR MALPRACTICE. ANY MODIFICATIONS TO THE MACHINE WILL AFFECT ITS WORKING PARAMETERS AND SAFETY FACTORS. REFER TO THE MANUFACTURERS BEFORE FITTING ANY NON STANDARD EQUIPMENT OR PARTS.

THE MANUFACTURERS ACCEPT NO RESPONSIBILITY FOR ANY MODIFICATIONS MADE AFTER THE MACHINE HAS LEFT THE FACTORY, UNLESS PREVIOUSLY AGREED IN WRITING. THE MANUFACTURERS WILL ACCEPT NO LIABILITY FOR DAMAGE TO PROPERTY, PERSONNEL OR THE MACHINE IF FAILURE IS BROUGHT ABOUT DUE TO SUCH MODIFICATIONS, OR THE FITMENT OF SPURIOUS PARTS.



**RP400**  
**OPERATIONAL AND SAFETY**  
**REQUIREMENTS**

**PRE-DELIVERY**

- 1.1 Drive coupling alignments, pan and star meshing of pan rack and drive gear.
- 1.2 Operating clearances star blade to pan. Fixed blade to pan wall.
- 1.3 Discharge blade to pan base.
- 1.4 Rollers to register ring.
- 1.5 Correct oil level in gearboxes. All grease points charged. Gear teeth greased.
- 1.6 Air system tested.
- 1.7 Door operation and seating.
- 1.8 No load test. Correct rotations.

**PRE INSTALLATION**

- 2.1 Check consignment.
- 2.2 Offload equipment using certified lifting gear of suitable capacity, by a competent person (see separate chart for nett weight).

**INSTALLATION**

- 3.1 Refer to contract arrangement and site instructions.
- 3.2 Mixer to be mounted on supports of adequate strength and rigidity to prevent undue vibration when mixing and securely bolted.
- 3.3 Mixer frame to be level on structure, add packers as required.
- 3.4 Check that pan is correctly seated on Rollers and that pan rack and drive gear are in correct mesh.
- 3.5 Check locating rollers to register ring.
- 3.6 Check operating clearances star blade to pan. Fixed blade to pan wall. Discharge blade to pan base. See maintenance section Ops Manual.

## **ELECTRICAL SERVICES**

- 4.1 Refer to wiring diagram in Ops Manual. All wiring to be undertaken by competent electrician.
- 4.2 Refer to pneumatic circuit diagram in Ops Manual. Connect compressor. Supply compressed air 5.5 bars as required (80psi).
- 4.3 Refer to wiring diagram in Ops Manual when connecting air control valves.
- 4.4 Remove transit bar and ring from door BEFORE starting mixer.
- 4.5 Ensure starters are mounted away from mixer on supports free of vibration.
- 4.6 Ensure starters are fitted with correct overloads – see technical specification power units.

## **OPERATION**

- 5.1 Correct oil level, gearboxes. Air line lubricator.
- 5.2 Mixing pan clear of loose nuts and bolts to prevent damage to fingers and blades.
- 5.3 Check correct rotation – mixing star – anti clockwise; mixing pan – anti clockwise. All when viewed from the top.
- 5.4 Discharge door and blade correct operation.
- 5.5 Blade operating clearances adjust in line with maintenance instructions.
- 5.6 Never exceed manufacturer's maximum capacity as detailed in specification.

## **SHUTDOWN**

- 6.1 Prior to any work being carried out mixer to be isolated and physically locked off. Recommended equipment double key exchange system.
- 6.2 Follow procedure detailed in company and users' Health and Safety Policy at all times.
- 6.2 Ensure all storage bins containing materials to be mixed are isolated.

6.3 Shut off water supply and drain off water tank or flowmeter

## **MAINTENANCE**

- 7.1 Ensure that all maintenance is carried out in accordance with the Parts and Operating manuals and proprietary manufacturer's specific instruction.
- 7.2 Isolate electrical and other services to the mixer as section 6 above.
- 7.3 Service at recommended intervals.
- 7.4 Use Croker manufactured replacement parts supplied by WINGET LIMITED.

## **GENERAL**

- 8.1 Under no circumstances should the Maximum Batch Loads be exceeded by either weight and volume as stated in Technical Specification.
- 8.2 Mixer star blades to be checked daily for damage.
- 8.3 Pan rim and base wearing plates must be replaced before excessive wear causes distortion.
- 8.4 Ensure mixing pan is rotating concentrically and pan base is rotating in horizontal plane.
- 8.5 Mixer must not be stopped and started when there is mix in the pan.
- 8.6 Refer to Contract Drawing for scope of supply. Site instruction notes outlining weights etc.
- 8.7 Refer to Method Statement when installation and commissioning is responsibility of Winget Limited.

## **Nett Weights Max (kgs)**

9.1	RP50XD	788	RP1250XD	4840
	RP100XD	814	RP1500XD	4980
	RP200XD	1400	RP3000XD	7112
	RP400XD	2000	FP1000	4040
	RP550XD	2150	FP1500	4065
	RP850XD	2600	FP2000	4100

- 9.2 Refer to technical specification for nett weights of ancillary equipment.
- 9.3 Refer to contract drawing for nett weights of ancillary equipment.

## **Miscellaneous**

10.1 Noise measured in accordance with Directive 79/113 EEC- 85LPA.

# GENERAL ARRANGEMENT DRAWING TOP & SIDE VIEW

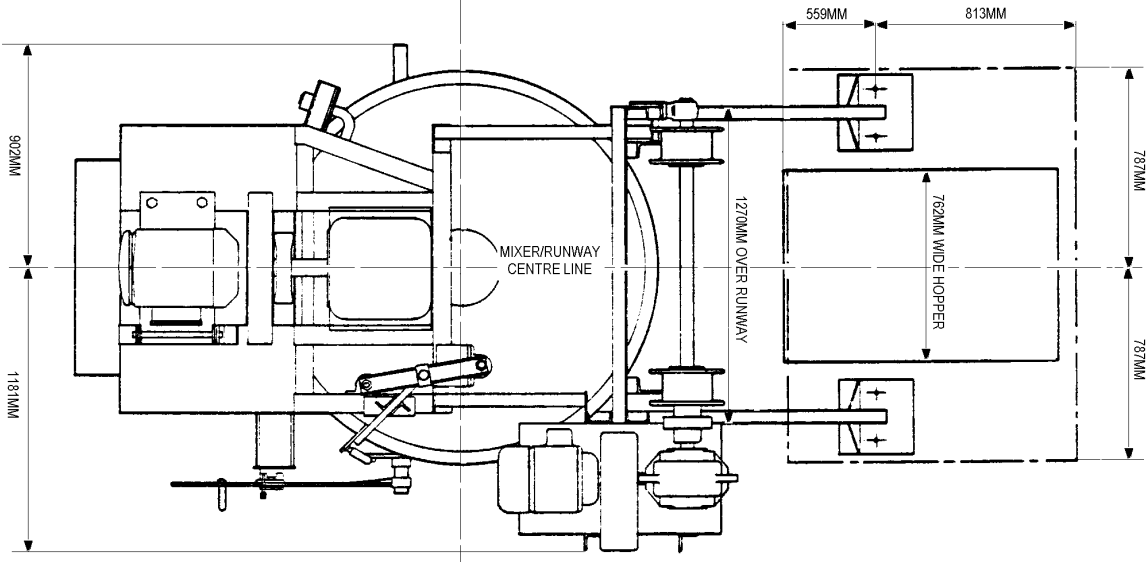
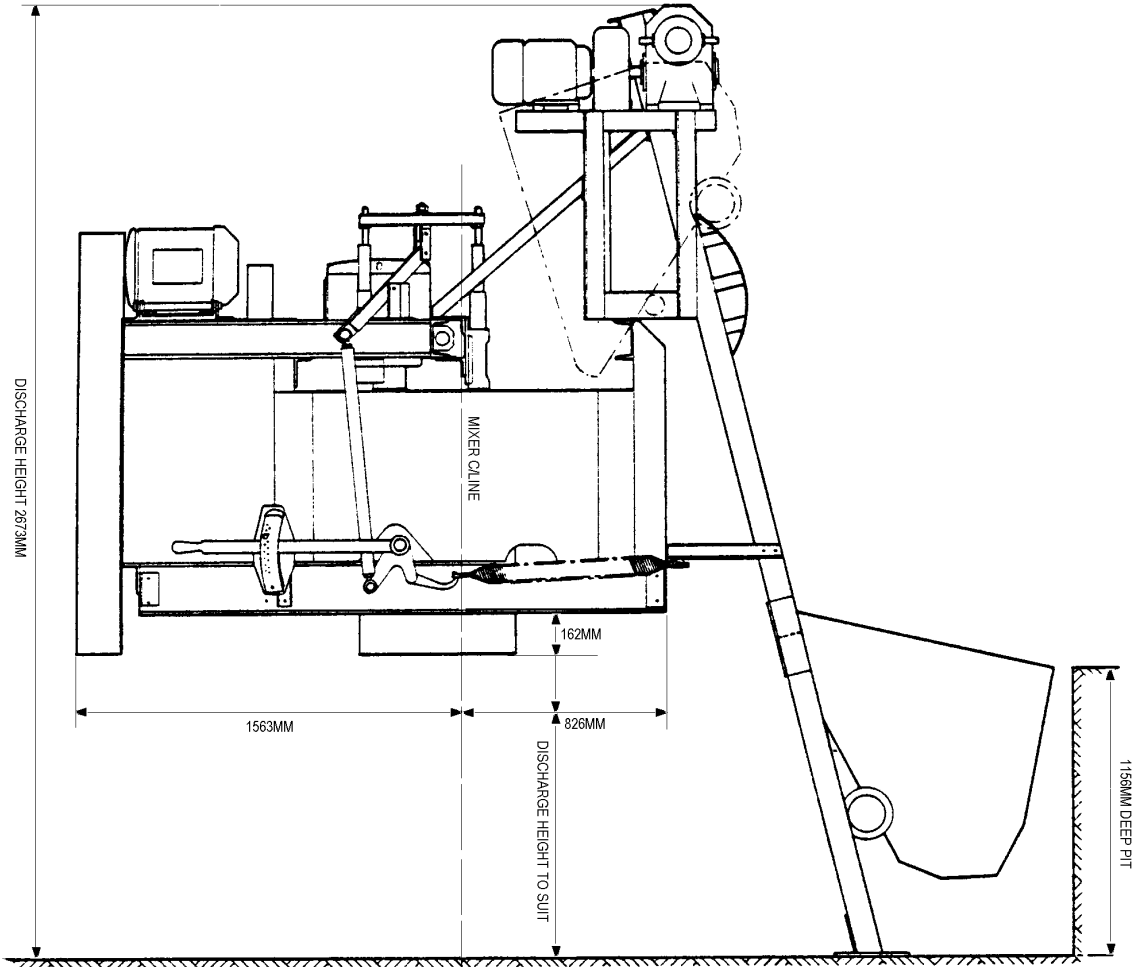

# GENERAL LAYOUT DRAWING OF PLANT WITH FEED HOPPERS

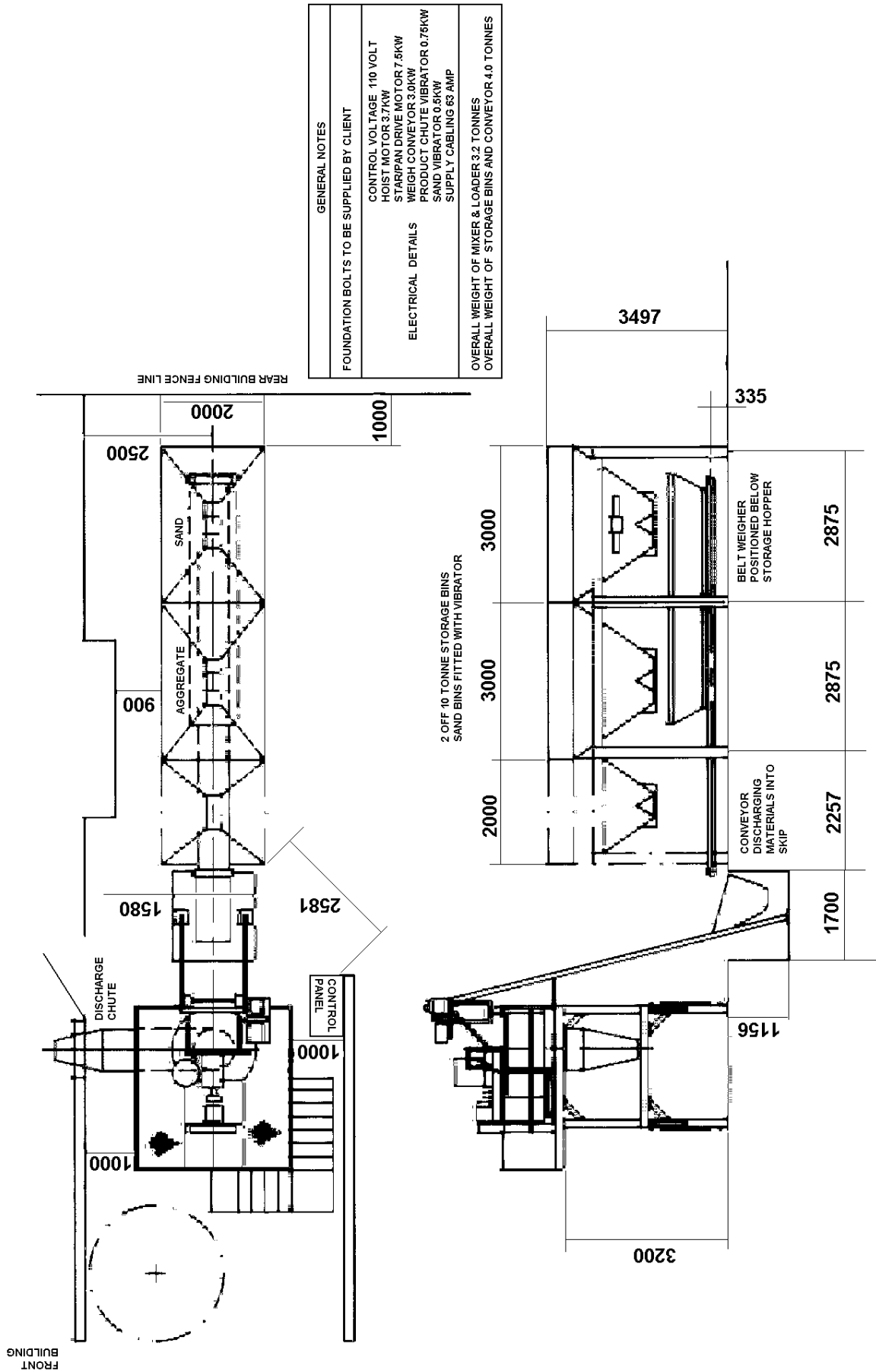

**OPERATING  
AND  
MAINTENANCE MANUAL**

**SECTION 2**

**INSTALLATION AND OPERATING  
INSTRUCTIONS**

## **PRE-INSTALLATION**

On arrival of the equipment it is advisable to check that all packages listed on the consignment note have been received.

The equipment must be offloaded using certified lifting gear of suitable capacity, by a competent person.

When unloading the mixer, care must be taken to ensure the discharge chute remains clear of obstructions as the chute and door hang below the chassis.

An outline drawing and bolt hold plan is normally sent prior to the despatch of the machine and will enable preparations to be made for the installation. With the `picture` of what the machine will look like when it is assembled, the ancillary equipment dismantled for transport can easily be identified.



## **INSTALLATION**

Please refer to contract arrangement and site instructions as applicable.

It is recommended that a concrete foundation (to take foundation bolts – not supplied) should be provided for each leg of the support structure and runway when fitted. When the machine is supplied without a support structure it should be mounted on supports of sufficient strength and rigidity to prevent undue vibration when the machine is working. When making provision for a loading hopper pit it is strongly recommended that the pit is concreted out so that it can easily be kept clean and free from any build up which could prevent the bottom limit switch from operating correctly.

Before completing the installation, check that the main mixer frame is level with a spirit level. Packings should be inserted as required under the structure legs or main frame. The packings under the mixing pan roller brackets are set during manufacturing and must not be disturbed under any circumstances.

Check that the pan is seated and that the pan rack and drive gear are in mesh.. Also check that all the blade clearances are in line with the maintenance instructions. It is essential that the machine is level and all four rollers are in contact with the pan roller track, if any of the rollers fail to revolve the trouble is usually found to be uneven foundations.

On connecting to the power supply, the wiring diagram must be referred to. A check that the wiring is correct is rotation of the following:-

- The mixing pan and mixing star rotate anti-clockwise when looking from the top.
- The loader winch rotates anti-clockwise looking from the rope drum end and when the raise button is pressed.
- The whirler unit rotates clockwise when looking from the top.

It is advisable to mount the starters away from the machine on supports free from vibration. Ensure that the starters are fitted with suitable overloads – see technical specification – power units.

When wiring the air control valves refer to the correct wiring diagram in the control panel and make sure the door control solenoid is energised only when the control switch is in the 'DOOR OPEN' position.

The 55 litre (12 gallon) 'Invarac Water Tank' is fitted with a 25mm (1") bore hose inlet connection which will operate at all pressures up to 100 p.s.i.

Alternative inlet valves to suit very low water pressures are available if required.

A simple Water Flow Meter is available as an option to the water tank, this has a range of 0-100 litres and features an adjustable flow indicator with a reset facility allowing very accurate measurement of water flow irrespective of the pressure. The Flow Meter is normally fitted with a manual 'on/off' valve and is normally protected by a washable in line strainer.

A supply of compressed air at 5.5 bars is required. The inlet for the connection from the air line is tapped ½" B.S.P. A drop in pressure will cause incorrect operation of the pneumatic system.

## **OPERATING THE MIXER**

Before starting production the following points should be checked:-

- (1) That there is oil in (a) the Star Drive Gearbox  
(b) the Loader Winch Gearbox (when fitted)  
(c) the Air Line lubricator (situated in the control valve box).
- (2) The Mixing pan should be clear of loose nuts, bolts, spanners etc., as these will damage the fingers and blades.
- (3) Check that the Discharge Door and Discharge Blade are operating correctly.
- (4) Check that the blade clearances are correct and if necessary adjust, in line with the maintenance instructions.
- (5) Check that the limit switches on the loader stop the Loading Hopper in the required positions at the top and bottom of the runway.
- (6) Check that the Water tank is set to the required amount and is filling up to this level. (See later page for further information on Water Tank operation).
- (7) If a Flow Meter is fitted check that the pointer is reset to zero and the strainer is clean and free from debris
- (8) When Weigh Gear is fitted check that the setting arrangements and lubrication requirements have been carried out. (See the Salter and Pfister Parts Lists for details).

### **IMPORTANT:**

The CUMFLOW is a high performance Mixer.

The following precautions are necessary to obtain the best results and to avoid damage to the Mixing Star and Drive.

### **AGGREGATES:**

Strict control of graded aggregates must be maintained. Maximum Size 19mm (3/4”).

Oversize lumps of aggregate or rogue material must be prevented from entering the Pan.

### **MIXING STAR BLADES:**

They are of a special shape and material to prolong wear life. They should not be modified in any way and only replaced by genuine 'WINGET CROKER' spares.

Daily check is advised to ensure that the Blades/Wearing Pieces are securely bolted and undamaged.

### **PAN RIM & BASE WEARING PLATES:**

They must be replaced before excessive wear causes distortion.

### **MAXIMUM BATCH LOADS:**

**Under no circumstances should** the Maximum Batch Loads quoted be exceeded nor should the Mixer be stopped and re-started when there is a mix in the Pan.

After each mix the contents of the pan must be completely discharged before attempting to close the discharge door. At the end of each period of operation the mixing pan, mixing blades, discharge blade and fingers, discharge chute, discharge door and seating must be washed down to prevent concrete setting on them and so impairing the efficiency of the machine.

### **WARNING:**

THE MAUFACTURER ACCEPTS NO RESPONSIBILITY FOR ANY DAMAGE OR FAILURE RESULTING FROM OPERATIONAL MIS-USE OR MALPRACTICE.

# **OPERATING INSTRUCTIONS FOR WEIGH GEAR**

## **MECHANISM**

### **PFISTER WEIGHER**

- (1) Before operating check that the dashpot is filled with Total Azolla ZS32 or Azolla ZS46 or equivalent.
- (2) Ensure the pit is free from obstructions that may result in the hopper not reaching the bottom limit switch
- (3) **Setting the Weigher to Zero**

The hopper should be lowered until the limit switch operates, (i.e. above the hopper stops), then lowered onto the hopper stops by means of the rope tension release switch, until the hopper rope is slack, if not the weigher will not register a true reading. The dial should read zero when this has been done, if not, adjust the pointer by means of the zero adjusting nut on top of the dial head. (see item 20 on the relevant parts page)

- (4) If the pointer on the dial oscillates while the machine is in action, (i.e. through vibration), turn the damping adjusting nuts (items 6 & 7 parts page) down the spindle until the oscillations stop, then lock the two nuts together.
- (5) On a daily basis before weighing check the pointer of the dial for zero position. If the pointer isn't exactly on zero, check to see if the hopper and weighbridge have got free play and, if necessary clean the hopper or weighbridge. If zero cannot be obtained, adjust by means of the zero adjusting nut on top of the dial head. (item 20)
- (6) If the dial reads heavy or light at full load, adjustments can be made by moving the adjustable knife edge. **NOTE** This adjustable knife edge is set in our works prior to despatch and should only be moved if the above instructions have been carried out without result.

### **SALTER WEIGHER**

- (1) Ensure the dashpot is filled with a Total S.A.E. 140 oil.

(2) Ensure the pit is free from obstructions that may result in the hopper not reaching the bottom limit switch

(3) **Setting the Weigher to Zero**

The hopper should be lowered until the limit switch operates, (i.e. above the hopper stops), then lowered onto the hopper stops by means of the rope tension release switch, until the hopper rope is slack, if not the weigher will not register a true reading. The dial should read zero when this has been done, if not, adjust the pointer by means of the zero adjusting nut on top of the dial head. (see item 1 on the relevant parts page)

(4) On a daily basis before weighing check the pointer of the dial for zero position. If the pointer isn't exactly on zero, check to see if the hopper and weighbridge have got free play and , if necessary clean the hopper or weighbridge. If zero cannot be obtained, adjust by means of the zero adjusting nut on top of the dial head. (item 1)

(5) If the dial reads heavy or light at full load, adjustments can be made by moving the adjustable knife edge. **NOTE** This adjustable knife edge is set in our works prior to despatch and should only be moved if the above instructions have been carried out without result.

## **HYDROSTATIC LOADCELL & GAUGE**

The Hydrostatic Load Cell is connected by a flexible capillary tube (approx 9.7 metres long) to a 300mm (12") diameter weigh gauge.

The whole system is assembled and filled with fluid under vacuum and under no circumstances should any of the components be disconnected, in the event of component damage the complete assembly should be returned to Winget Limited for repair.

The system is factory calibrated and any variation between the calculated tare and the actual tare recorded can be corrected by means of the tare adjustment knob on the side of the gauge.

With no load acting on the loadcell the pointer will be below zero, this is to accommodate the weight of the hopper. When the hopper is placed on to the loadcell the pointer will register zero. Final zero adjustment can be made via the zero adjustment knob on the side of the gauge housing.

# **OPERATING INSTRUCTIONS FOR 'INVARAC ' 55** **LITRE (12 GALLON) WATER TANK**

**TO DISCHARGE IN STAGES:** When the tank is used for a partial discharge (i.e. not a complete discharge in one go) slacken the wing nut so that the release lever is slack, then use the discharge lever for releasing the water. When the tank has emptied the release lever must be depressed before any water can enter the tank. Just a light touch is necessary.

**NOTE** It is necessary to pull the discharge lever **right down** for the first discharge. This locks the inlet valve in the 'shut off' position and thereafter the lever can be operated without pulling it to its full extent, i.e. the lever controls the amount of water released.

**COMPLETE DISCHARGE:** Lock the release lever in the 'down position by means of the wing nut.

**METHOD OF OPERATION:** Set the indicator to the required quantity of water and discharge by means of the discharge lever at the tank base. The lever must be pulled right down and held until the water is discharged. This action shuts off the inlet valve and stops water from entering the tank.

For accurate quantities, measure the water discharged and adjust by means of the handle, ten turns of the handle are equal to 1 gallon or 4.54 litres, (1.25 turns to 1 pint or 0.568 litres). Once set each batch of water will be the same.

The tank is designed for accurate water measurements and will operate satisfactorily on mains water pressure up to 100 p.s.i.

## **INDICATORS**

**10 Turns    4.54 litres    1 gallon**

**1.25 Turns    .568 litres    1 pint**

**1 Turn        1 pound**

## **CAPACITY**

**55 litres        12 gallon        maximum**

**18 Litres        4 gallon        minimum**

**THE ABOVE INFORMATION APPLIES TO IMPERIAL GALLONS ONLY**

If the overnight temperature is expected to drop to or near freezing it is recommended that the water tank is completely drained each night or at the end of each shift to prevent damage to the tank.

## **LUBRICATION**

The indicator screw spindle must be kept clean and regularly greased. The chain adjustment should be checked frequently and also greased regularly. The square end of the centre spindle on the top of the tank should be checked regularly for free movement and grease applied as necessary.

## **OPERATING INSTRUCTIONS FOR 0-100 LITRE WATER FLOWMETER**

The simple manually operated 0-100 litre Water Flow Meter is available as an option to the water tank and is normally mounted on the side of the mixer feeding directly into the pan. The meter is normally fitted with 1" hose tail connectors but different sizes of water inlet connections to suit various hose diameters are also available. The meter is normally provided with a simple 'on/off' valve and inline filter/strainer mounted next to but down stream of the flowmeter.

## **OPERATION**

On a daily basis before use the strainer should be removed and checked for debris and obstructions, cleaned and refitted. Ensure the on/off valve is in the 'off' position and turn on the main water supply. Set the adjustable pointer on the dial face via the central knob to the required amount of water. Check the indicator reads zero, if not operate the reset lever on the side of the meter which will reset the indicator. Turn the on/off valve slowly to the 'on' position watching the movement of the indicator around the dial, when the indicator reaches the pointer sharply turn valve to the 'off' position. The indicator will register the amount of water delivered. Operate the reset lever to bring the indicator back to zero and repeat the operation for each batch of material mixed.

When shutting down the mixer either at night or at the end of each shift it is recommended that the main water supply to the flow meter and 'on/off' valve is shut off.

If it is expected that the overnight temperatures will drop to or close to freezing it is recommended that the Flow Meter, Valve, Filter and Pipework are drained to prevent damage.



# **OPERATING THE MIXER**

## **SAFETY NOTES**

Never operate the mixer unless you have read and fully understand the contents of the Operators Manual

Never operate the mixer whilst wearing loose fitting clothing

Never reach inside the Pan whilst it is rotating

Never operate any equipment unless you have received adequate training

Cement, certain other minerals and organic compounds can cause skin irritation leading to Dermatitis. Always use Personal Protective Equipment i.e. gloves etc to protect the skin from direct contact. If in any doubt about the materials being used consult your employers COSHH manual

Wear Eye protection to protect your eyes from dust and liquid splashes

Do not attempt to remove the pan single handedly, obtain assistance, use the Pan Trolley (if provided) or use suitable lifting equipment

Do not operate the mixer with any of the guards removed, safety devices or interlocks disconnected. They are there to offer you some protection, ensure they are correctly maintained

Carry out the daily maintenance before operating the mixer and report defects to your supervisors

Oils, Greases and Lubricants are skin irritants and prolonged direct skin contact can cause skin cancer. PPE or barrier creams should be used when carrying out maintenance work, wash your hands on completion

Always dispose of waste oils and lubricants in a proper manner, it is illegal to pour it down drains or bury it. Contact your local authority for a list of authorised disposal sites

Always disconnect the power supply at the mains before carrying out any maintenance work or cleaning the equipment down. Do not turn on the power until everything has dried out

Do not allow waste from the wash down process to enter the public drainage system unless it has been properly filtered.

Decals and Instruction Plates are attached to the equipment to warn against hazards and assist in the safe operation of the equipment, if damaged or defaced they should always be replaced.

It is likely that clutch and/or brake linings may contain asbestos and suitable precautions should be taken to avoid breathing in the dust, protective clothing should be worn. Hands should be washed immediately after handling components and old discarded parts or linings should be disposed of in a responsible manner in line with local or national regulations covering the disposal of asbestos waste.

**OPERATING  
AND  
MAINTENANCE MANUAL**

**SECTION 3**

**TECHNICAL SPECIFICATION  
AND MAINTENANCE**

# TECHNICAL SPECIFICATION OF CUMFLOW RP400

<b><u>CAPACITIES:</u></b>	Maximum Batch Capacity	by Weight	610 kgs
		by Volume	400 litres
	Nominal Output (Based on 2.42kg/lt)		254 litres
	Nominal Output (Based on 2.162kg/lt)		282 litres
	Hourly Output @ 40/50/60 batches per/hr		11m <sup>3</sup> /13.75m <sup>3</sup> 16.5m <sup>3</sup>

**BATCHLOADER CAPACITY** 576 kg

**AGGREGATES:** Maximum Aggregate Size 19 mm

**MIXER FRAME:** Strongly constructed from welded Steel Channel

**MIXING PAN:** Steel Base Pan mounted on four wide track rollers with central discharge door. Pan Rim, Base and Discharge Door fitted with renewable Wearing Plates.

**MIXING STAR:** Fitted with 3 Spring loaded Star Blades, two at Pan floor level and one for high level mixing.

**FIXED BLADE:** Spring loaded pan side scraper assembly. Reversible when worn.

**DISCHARGE BLADE:** Lever operated in conjunction with the Discharge Door.

**WHIRLER:** Intermittent blades mounted on vertical split shaft.

<b><u>POWER UNITS:</u></b>	Mixing Star) Combined Motor	7.5 kw
	Mixing Pan)	
	Loader Motor (where fitted)	3.7 kw
	Whirler Motor (where fitted)	7.5 kw

<b><u>DRIVES</u></b>	Primary	Vee Flat
	Secondary	Roller chain to pan and star drive.
	Mixing Pan	Renewable cast bevel rack and bevel pinion
	Mixing Star	Machine cut bevel gears
	Whirler	Vee Rope Drive

<b><u>SPEEDS</u></b>	Speed of Pan	12 rpm
	Speed of Star	56 rpm
	Speed of Loading Hopper	21 metres/min
	Speed of Whirler	720 rpm

**FREE AIR CONSUMPTION (PER BATCH 80 PSI)** 63.7 litres

**WEIGHTS (UNLADEN)** Without Loader  
With Loader

2655 kg  
3471 kg

**ELECTRICS**

Motor Voltage

415V 3ph 50hz  
option 60 hz

Control Voltage

110V

**MACHINE SAFETY DIRECTIVE**

All Gears are suitably guarded.

# MAINTENANCE

## IMPORTANT

**ALWAYS ENSURE APPARATUS IS ISOLATED FROM MAINS SUPPLY BEFORE COMMENCING MAINTENANCE.**

## SHUTDOWN PROCEDURE

Prior to any work being carried out the apparatus is to be isolated and physically locked off.

We recommend a double key exchange system.

Safe access to equipment with one access door and one control point.

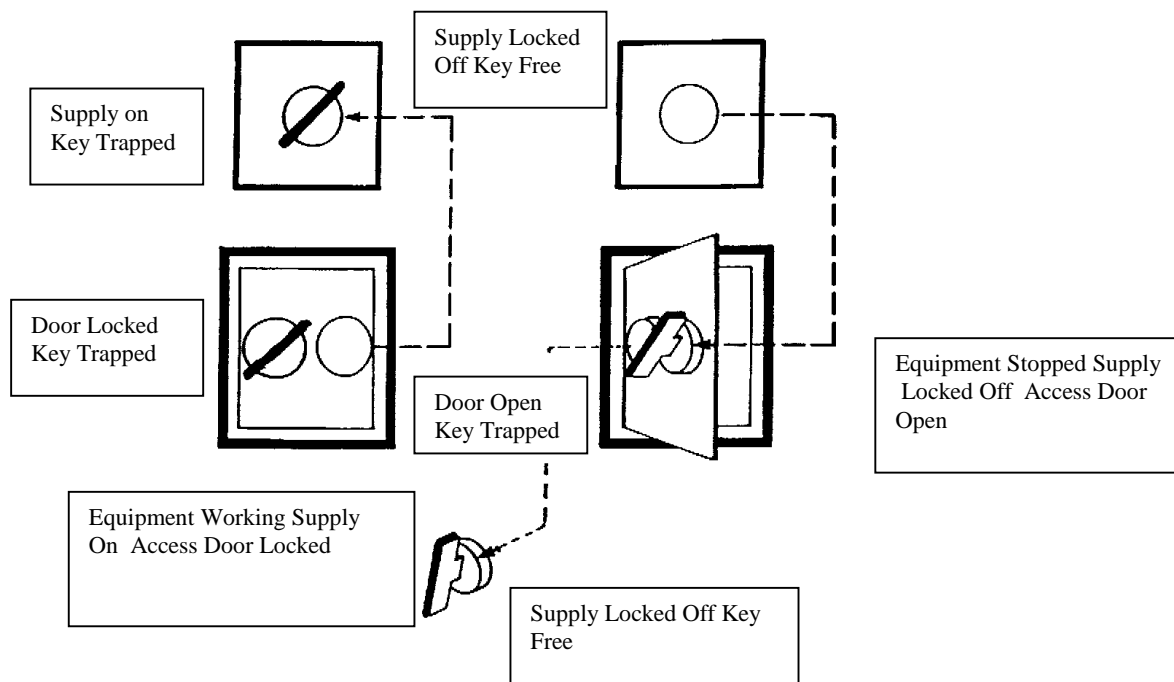

Follow the procedures detailed in your Health and Safety Policy at all times.

Ensure all storage bins containing materials to be mixed are isolated.

Shut down the water supply and drain off any tank or flowmeter fitted.

# MAINTENANCE OF MIXER

## IMPORTANT NOTE:

Ensure that all maintenance is carried out in accordance with the Parts and Operating Manual and Proprietary Manufacturer's specific instruction.

## PROCEDURE

- 1 ISOLATE ELECTRICAL, PNEUMATIC AND OTHER SERVICES TO THE MIXER (see separate section).
- 2 Service at recommended intervals.
- 3 Use **Croker** manufactured replacement parts available from **WINGET LIMITED**.
- 4 Ensure all safety guards and interlocks are reinstated prior to operating the mixer.
- 5 Main items of wear (see Section 4).
  - A) Star Blades
  - B) Fixed Blade
  - C) Discharge Blade
  - D) Whirler Blades

Access to mixing pan internals is via the safety interlocks. Each of the above are bolted components and are replaced by simple method and usually achieved in situ without dismantling other components.

- E) Pan base and rim wearing plates are also bolted construction and can be replaced in situ. However, pan covers will need to be dismantled to provide the necessary access.
- F) Other items prone to less wear are star blade fingers, lower whirler shaft assembly and mixing star. Each can be replaced again in situ but pan covers would require tensing to provide necessary access.
- G) Pan rollers can be adjusted to accommodate wear during operation. These can be replaced when required in situ using jacking method to support pan and provide the necessary access.

## MAINTENANCE AND LUBRICATION

**DAILY:** Using Total EP2 Grease (or equivalent) grease the following points:-

Pan Roller Spindles	4 Points
Discharge Blade Lifting Control Gear	7 Points
Air Cylinder Lever Pivot Holder	1 Point
Star Gearbox and Conical Bearings	5 Points
Mixing Blade Finger Bearings	2 Points
Fixed Blade Finger Bearing	1 Point
Loading Hopper Rollers	4 Points
Whirler (where applicable)	2 Points

Inspect and top-up if necessary:-

Air Line Lubricator

Use Total Azolla 27 (or equivalent)  
or suitable Pneumatic Tool Oil

**WEEKLY:** Inspect and top up if necessary:-

- |                                    |   |
|------------------------------------|---|
| (1) Star Gearbox                   | Use Total Carter EP320 (or equivalent)  |
| (2) Chain drip-feed Lubricators    | Use S.A.E. 30 Oil   |
| (3) Loader Winch Reduction Gearbox | Use Total Carter EP320, Total Carter EPHT320 or Total Carter SY320 (or equivalent). Carter EPHT and SY320 are Synthetic Oils which will not mix with either Mineral Oils or other makes of Synthetic Oils. If in doubt drain and flush the gearbox before topping up. |

### Inspect and Adjust

- (1) Pan Gear and Pinion – Apply Open Gear Lubricant or equivalent as required.
- (2) Adjust Star Blades, Fixed Blades and Discharge Blade to the following settings, also make sure that Blade fingers are free in their bearings and that the springs are clear of obstructions.

Mixing Blade: (3 mm) clear of pan base. Adjust by moving the blade down its finger.

Discharge Blade: Just touching pan base when finger bridge is resting on stop sleeves. Adjust by moving bridge up or down fingers.



## Discharge Door Control

### Spring:

The spring must be kept clean and free from obstruction.

### Fixed Blade:

(3 mm) clear of pan base and just touching pan rim. Adjust by moving hinge brackets along its slots and blade up or down its fingers. Re-set spring to 107 mm (4") overall length after setting blade.

- (3) After the first week's running the Vee Belt Drive will need adjustment to take up initial wear and stretch. At the correct tension it should be just possible to twist each belt through 90° when gripped between finger and thumb midway between pulleys.
- (4) Loading Hopper Wire Rope – clean off grit etc. and inspect for broken strands. Clean and apply a suitable wire rope dressing.

## **MONTHLY:**

### **Inspect:**

- (1) Driving Chain for misalignment indicated by wear on the sides of the sprocket teeth. Rectify immediately. Adjust jockey pinion if necessary so that the chain is just off slack, excessive tightness will accelerate wear.
- (2) All blades for wear – replace when worn.
- (3) Pan rim, base and door wear plates – replace when worn
- (4) Pan Roller Bearings – replace if necessary
- (5) Pan Door Bearing – replace if necessary
- (6) Pneumatic system for leaks – repair or replace damaged parts.
- (7) Pneumatic Cylinders. Make sure that the door cylinder piston rod is at the end of its travel when the discharge door is just home in its seating.
- (8) Pfister or Salter Weighers. Clean the knife abutments by means of a brush and grease them thoroughly with Total EP2 grease or equivalent.

## **CAUTION:**

**BEFORE WORKING UNDER LOADING HOPPER, REST HOPPER ON SAFETY BOLTS. DO NOT FORGET TO REMOVE THESE BOLTS BEFORE RE-STARTING THE MACHINE**

- (9) Loader Magnetic Brake (see below for NR Range brake units.) – adjust if necessary, to the following instructions (these instructions apply only if

a separate brake unit is fitted, refer to the manufacturers if a combined motor and brake unit is fitted) :-

### Mounting:

Set the brake so that the horizontal centre-line of the shoe corresponds with the centre-line of the brake wheel shaft and the shoe pivots are equally spaced from the vertical centre-line.

### Installing:

Slacken back equalising screw (Item 14) Slack nut (Item 5) and adjust screw (Item 3) to give required braking torque.

### **WARNING:**

The end of the adjusting screw (Item 3) must always be visible in the hole at the end of the adjusting nut (Item 6).

Set nuts (Item 5) so that contact is made with the load spring block in the shoe lever when solenoid plunger has moved through half its stroke. Once properly set, this setting should not be altered. With solenoid plunger right down, set equalising screw (Item 14) to give equal friction lining clearances.

Tighten locknuts (Item 5 & Item 14) and be sure that the load spring bracket is in place.

Check adjustments frequently and lubricate brake shoe pivots. To adjust for wear, screw in adjusting screw (Item 3) until the adjusting nuts are clear and only touch lever (Item 1) when plunger is depressed through half its stroke.

When new Brake Linings are fitted, repeat all adjustments. Refer to notes on safe handling and disposal of Asbestos waste and Brake Dust.

Orders and enquiries should always state full description of parts required. The serial number on the brake should always be quoted and when ordering replacement brake shoes give the dimensions and number of rivet holes.

Check that the limit switch on the loader stops the hopper in the required position at the top of the runway.

When operated the limit switch should stop the motor and apply the magnetic brake unit.

If a Batch Weigher is not to be used in conjunction with the Loader, then the skip track must be extended and a lower limit switch and hopper stops incorporated.

The loading hopper must operate the lower limit switch before the hopper stops are reached and allowance made for the rope to slacken once the hopper is in the loading position.

- (10) NR Range Loader Magnetic Brakes – adjust if necessary, to the following instructions (these instructions apply only if a separate brake unit is fitted, refer to the manufacturers if a combined motor and brake unit is fitted) :-

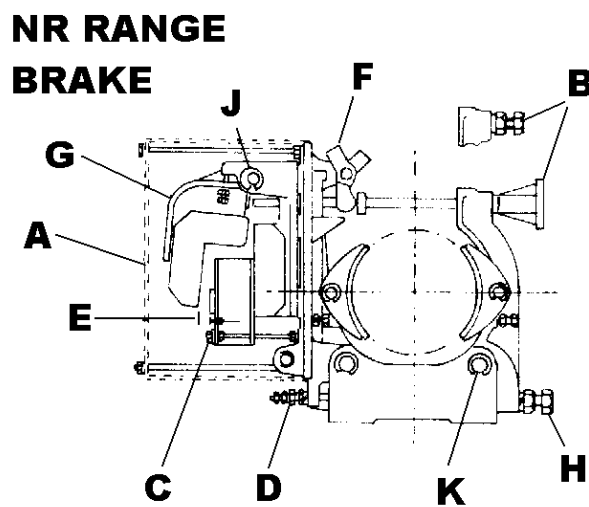

### MOUNTING

- (1) Release the spring pressure completely by unscrewing the torque screw H, in most cases the brake can now be slipped over and off the brake drum. If the brake cannot be slipped off the drum due to the proximity of equipment i.e. motors etc, the plain arm can be removed by taking out the pivot pin K and withdrawing the arm from the base. It may be necessary to remove the top rod.
- (2) Set the brake unit in position on the bed plate, insert the fixing bolts and screw down finger tight.
- (3) If previously removed replace the plain arm, rod and pivot pin. With the brake base resting evenly on the bed plate tighten up the torque screw H until the brake drum is gripped tightly by the shoes.

- (4) Tighten down the fixing setscrews or bolts and set the brake arm shoe stop screws Against the shoes to prevent them dropping in the released condition.

## **WIRING**

A 3/4" screwed conduit entry is situated in each side of the base of the armature housing to accommodate the wiring to the terminals, it is essential that the conduit or lead in be flexible.

## **SETTING UP**

- (1) Adjust and lock the torque screw H so that only 3mm (1/8") of further adjustment is available to compensate for any reduction in torque due to any wear of the brake linings.
- (2) Remove cover A and with no current flowing set gap E, indicated on the brake label, by adjusting the handwheel or alternatively the screw B. Replace the cover.
- (3) Adjust the setscrew D so that both shoes lift equally when the brake is energised.
- (4) When required the brake can be released manually by applying pressure to the release device F, using a suitable lever

## **MAINTENANCE AND SERVICE**

**NOTE**, until it is obvious that the friction surfaces have bedded down completely, gap E should be should be carefully checked at frequent intervals. The length of this period will depend on the frequency of the operation of the brake. After this period normal maintenance only will be required. The only lubrication required is an occasional light application to the armature spindle bearing through the holes provided.

## **COIL REPLACEMENT**

Isolate the electrical supply. Remove the armature cover A and disconnect the coil leads. Slacken the top rod adjustments by rotating the handwheel or alternatively the screw B anti-clockwise. Remove the e-clips on the armature spindle J and withdraw the spindle, lift out the armature G. Remove the eight nuts at C and withdraw the coil. Replace the coil and the nuts ensuring the positioning of the inner nuts prevents

distortion of the coil flange when the outer nuts are tightened. Refit the armature, spindle and e-clips, reset the gap E as previously described and reconnect the leads. Replace the cover.

## **BRAKE LINING REPLACEMENT**

Isolate the electrical supply. Release the torque spring pressure by unscrewing the torque screw N. Remove the shoe spindle and rotate the shoe around the drum by approximately 90° in an upward movement and withdraw. Fit new linings and reassemble. Reset as previously described under setting.

### **WARNING**

It is likely that the Brake Lining may contain asbestos and suitable precautions should be taken to avoid breathing in the dust, protective clothing should be worn. Hands should be washed immediately after handling components and old discarded parts or linings should be disposed of in a responsible manner in line with local or national regulations covering the disposal of asbestos waste

## **MAINTENANCE OF PFISTER WEIGHER**

### **MONTHLY**

Clean the knife edge abutments by means of a brush and grease them thoroughly using Total EP2 grease or equivalent.

### **EVERY THREE MONTHS**

Free the dashpot cylinder securing nut at the bottom of the cylinder, and cylinder flange . Remove the dashpot cylinder clean out and refill with new oil, either Total Azolla ZS32 or Azolla ZS46 or equivalent. Take care when removing the dashpot cylinder from its position as it must be replaced in the same position.

### **EVERY THREE MONTHS**

Clean the dial head. Remove the back cover plate and wash the elements in the dial head with clean diesel oil, i.e. springs, shaft, ball bearings and rack etc.

When cleaning the ball bearings move the rack up and down. After cleaning lubricate the elements with Total EP2 grease. The ball bearings should be lubricated with Total Azolla ZS10. Replace the back cover.

## **MAINTENANCE OF SALTER WEIGHER**

### **MONTHLY**

Clean the knife edge abutments by means of a brush and grease them thoroughly using Total EP2 grease or equivalent.

### **EVERY THREE MONTHS**

Free the dashpot cylinder securing nuts at the bottom of the cylinder, and cylinder flange, remove the dashpot cylinder cap. Remove the dashpot cylinder clean out and refill with new oil, Total S.A.E. 140 or equivalent. Take care when removing the dashpot cylinder from its position as it must be replaced in the same position.

### **ANNUALLY**

#### **WORM REDUCTION UNIT RENOLD WU5**

Drain and clean out the gear case and refill with Total Carter EP320, Total Carter EPHT320 or Total Carter SY320 or equivalent. (EPHT and SY320 are Synthetic Oils). Mineral and Synthetic oils are incompatible and will not mix, neither will different makes of Synthetic Oils. If in doubt thoroughly flush out the unit prior to refilling. When running conditions are severe the oil should be changed more frequently. (Capacities – 8.5 Imperial Pints: 4.0 Litres: 1.5 American Gallons).

### **NOTE**

Electrical cables particularly those with copper conductors suffer from a condition known as 'relaxation' which may cause wiring to work loose over a period of time, it is recommended that the tightness of wiring connections and terminals are checked following the first month in service.

## **SCRAPER SHOVEL FAULT FINDING**

### **Clutch Slip**

The most likely reason for clutch slippage is a drop in voltage, as the clutch cannot operate efficiently unless full voltage is applied.

## **VOLTAGE READINGS:**

Dynamo Output should read 15-17 volt

Automatic voltage Controller should read 15-17 volt

If the voltage readings differ significantly from those above check and adjust the dynamo drive belt and recheck the readings. If the voltage is still incorrect check the dynamo output by disconnecting both dynamo leads and placing the + lead of the test meter across terminals D & F and the – lead to earth. The dynamo should now give a reading of approximately 30-33 volts. If this reading is unobtainable the dynamo should be serviced and the brushes and commutator cleaned, if after servicing the dynamo the voltage is still incorrect the dynamo should be changed.

If the dynamo voltage is correct (i.e. 30-33 volt) check all the A.V.C. connections from the dynamo and to earth. If the voltage is still incorrect a replacement A.V.C. should be fitted, these are sealed units and cannot be adjusted.

If the voltages from both the dynamo and A.V.C. are correct (i.e. 15-17 volt) and the clutch still slips check the Winch unit for damaged Clutch Armature Plates, or contamination with grease or oil of the faces of both the Armature Plate and Magnet. If signs of contamination are present the affected parts should be cleaned with a suitable degreasing solvent (wear suitable protective clothing). Take care not to drench the clutch friction material, the friction material can be scraped to facilitate degreasing but no more than .001” of material should be removed.

### **Complete Clutch Failure**

Should the output voltage from the A.V.C. be correct the cause of the breakdown is most likely to be a break in the electrical circuit between the A.V.C. and the negative return to earth on the Clutch Carbon Brushes.

Check the shovel cable and switch by connecting a test meter set for continuity to both terminals on the shovel plug. Operate the switch and check the meter for a correct continuity reading. If the readings indicate a fault, replace the cable or switch as necessary.

In the event of the shovel circuit being correct, check all the connections between the two pin socket and clutch carbon brushes, paying particular attention to the following items:-

The wires connecting the Clutch Magnet to the Collector Ring which may have an internal break, or loose grub screw in the Collector Ring.

Check the Carbon Brushes and Slip Rings for deposits of grease, oil, cement dust or other contaminant. If necessary clean or replace.

Check the earth connection on the negative side of the brush mounting, this may be making a bad earthing contact. On some models the contact is made direct to the brush box, on others a separate wire is returned to earth on the A.V.C. mounting bolts.

### **Magnet**

The clutch magnet friction facing is designed to be set at .001” to .002” below the level of the magnet poles, the armature plates will have corresponding grooves worn by the magnet poles to a similar depth.

### **WARNING**

It is likely that the clutch lining may contain asbestos and suitable precautions should be taken to avoid breathing in the dust, protective clothing should be worn. Hands should be washed immediately after handling components and old discarded parts or linings should be disposed of in a responsible manner in line with local or national regulations covering the disposal of asbestos waste.



# LUBRICATION LAYOUT

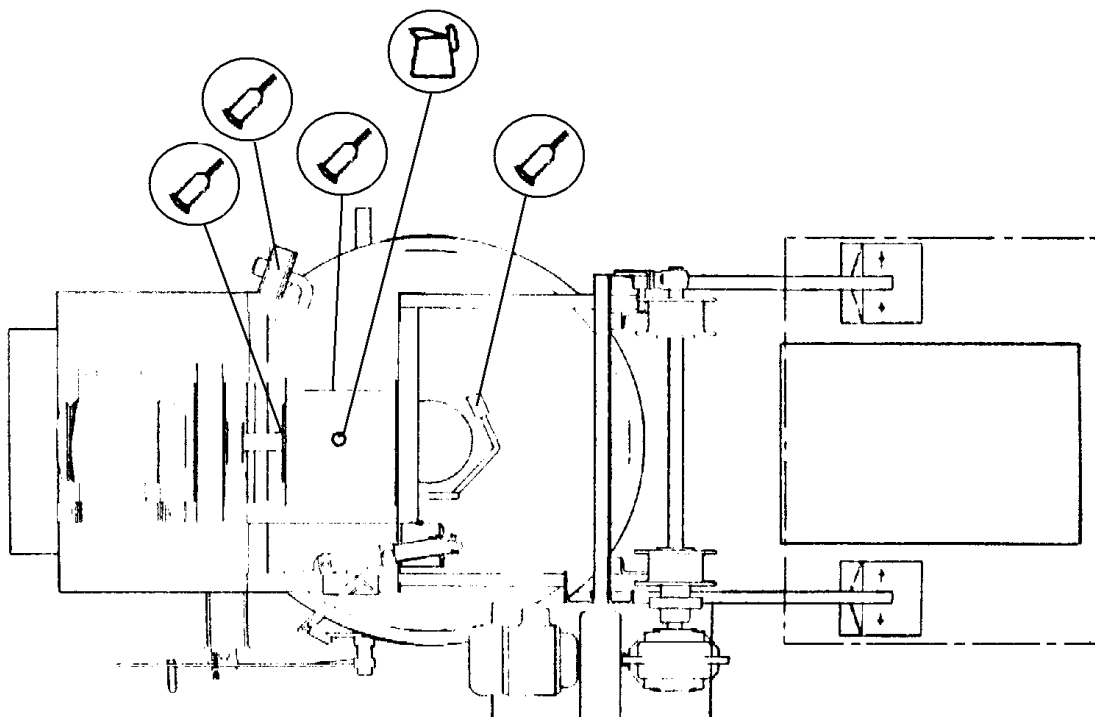
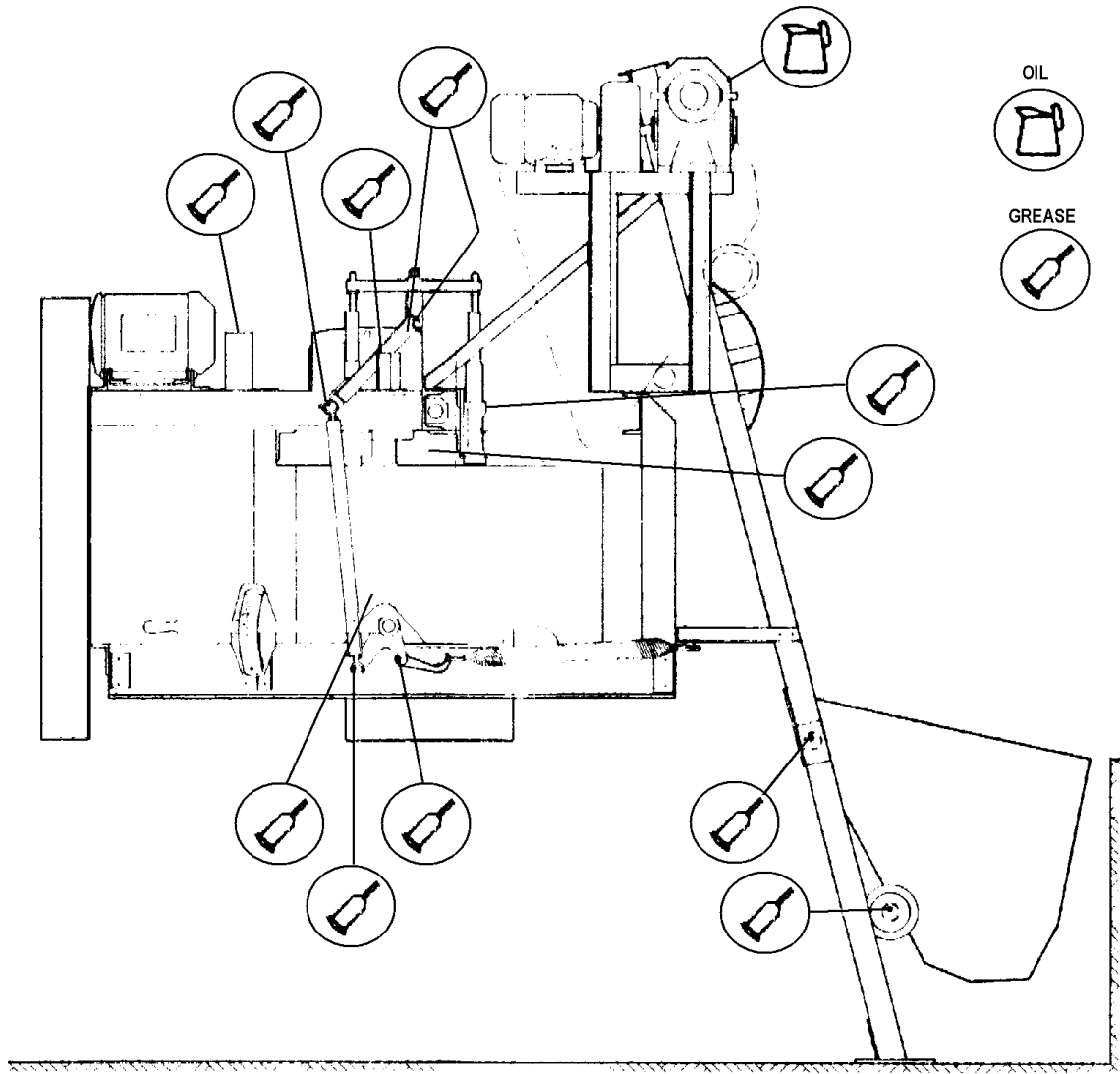

**OPERATING  
AND  
MAINTENANCE MANUAL**

**SECTION 4  
MIXER SPARE PARTS**

# RP400 PAN & STAR DRIVE ASSEMBLY

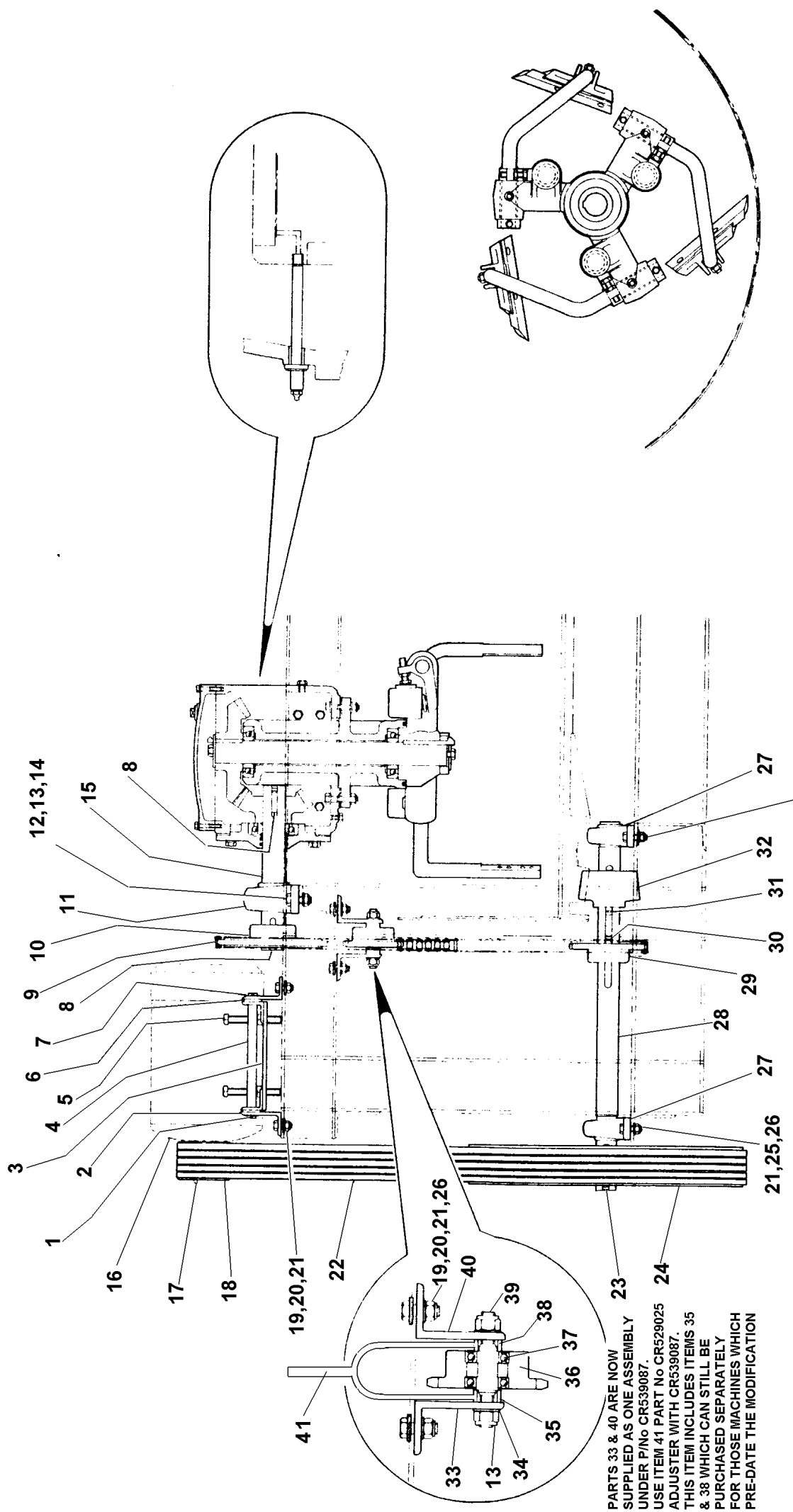

PARTS 33 & 40 ARE NOW SUPPLIED AS ONE ASSEMBLY UNDER P/No CR539087. USE ITEM 41 PART No CR529025 ADJUSTER WITH CR539087. THIS ITEM INCLUDES ITEMS 35 & 38 WHICH CAN STILL BE PURCHASED SEPARATELY FOR THOSE MACHINES WHICH PRE-DATE THE MODIFICATION

20,21,25,26

# RP400 PAN & STAR DRIVE ASSEMBLY

1	44S05E	Split Pin 3/16" x 1 1/2" Long	2
2	CR531914	Motor Bed Plate Pivot Angle	2
3	CR261381	Motor Bedplate	1
4	CR531927	Motor Bedplate Pivot Bar	1
5	CR531928	Adjusting Bolt	2
6	CR630034	Spacers	2
7	CR490010	Washer Flat 1"	2
8	CR329058	Key Parallel	1
9	CR200141	1" Pitch Simple Chain	1
9A	81S01	Connecting Link 1"	1
9B	134108002	Link & Half 1"	1
9c	134108003	Half Link 1"	1
10	CR200142	Chainwheel 38T c/w Taper Lock Bush	1
11	CR151092	Pillow Block Bearing	1
12	8S07J	Bolt M20x 65	2
13	59S05	Nyloc Nut M20	4
14	267S10	Washer Flat M20	2
15	CR520522	Star Drive Shaft	1
16	CR220156	Electric Motor	1
17	CR320087	Key Gib Head 12 x 85mm Long	1
18	CR340554	Motor Vee Pulley, 5 Groove	1
19	11S06G	Screw Set M16 x 45	4
20	105S07	Tapered Washer M16	6
21	59S11	Nyloc Nut M16	8
22	CR160026	Vee Belts, replace as a set	5
23	CR320084	Key Gib Head 16 x 110mm Long	1
24	CR340553	Flat Pulley	1
25	8S06G	Bolt M16 x 55	4
26	267S09	Washer Flat M16	10
27	CR151101	Pillow Block Bearing	2
28	CR520500	Bevel Pinion Shaft	1
29	CR200137	Chain Pinion 25T c/w Taper Lock Bush	1
30	CR329001	Key Parallel 18 x 11 x 60	1
31	CR329062	Key Gib Head 18 x 11 x 110mm long	1
32	CR460099	Bevel Pinion	1
33	CR531799	Jockey Pulley Support Bracket (R.H.) See item 40A	1
34	267S10	Washer M20	2
35	CR630057	Sleeve, also part of item 41 CR529025 Adjuster	1
36	CR200033	Chain Adjuster Pinion 19T	1
37	88S16C	Ball Bearing Sealed	2
38	CR630056	Sleeve, also part of item 41 CR529025 Adjuster	1
39	CR520138	Chain Adjuster Spindle	1
40	CR531799	Jockey Pulley Support Bracket (L.H.) See item 40A	1
40A	CR539087	Jockey Pulley Support Bracket Assembly replaces item 33 & item 40	1
41	CR529025	Adjuster, Chain Tensioner, use with item 40A	1
41A	59S04	Nut Nyloc M12	1
41B	267S07	Washer Flat	1

# RP400 MIXING STAR & GEARBOX ASSEMBLY

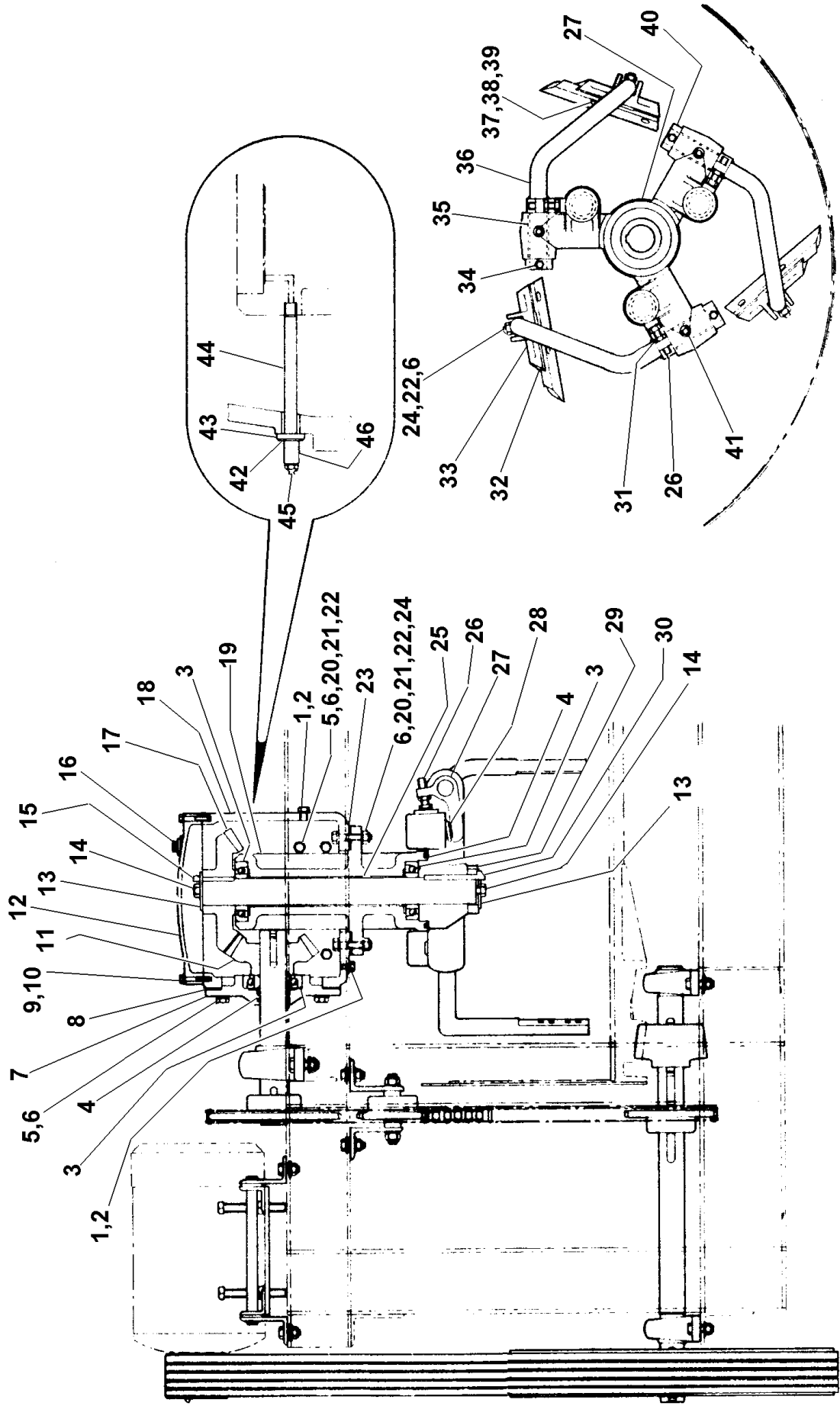

# RP400 MIXING STAR & GEARBOX

1	11S05D	Screw Set M12 x 30	2
2	CR490144	Fibre Washer M12	2
3	CR150223	Ball Bearing	3
4	CR560004	Felt Seal Set	1
5	11S06E	Screw Set M16 x 45	14
6	17S08	Spring Washer M16	26
7	CR210145	Star Gearbox Bearing Housing	1
8	CR560036	Bearing Housing Gasket	1
9	8S04H	Bolt M10 x 60	4
10	17S05	Spring Washer M10	4
11	CR460021	Bevel Gear 23T	1
12	CR210138	Star Gearbox Cover	1
13	CR630046	Washer Star Shaft	2
14	79S07C	Bolt 5/8" x 1 1/4" B.S.W.	2
15	CR329058	Key Parrallel 5/8" x 7/16" x 3	1
16	CR610003	Filler Plug	1
17	CR460020	Bevel Gear 32T	1
18	CR210144	Case Star Gearbox	1
19	CR210041	Star Conical	1
20	267S09	Washer Flat M16	14
21	CR490145	Fibre Washer M16	14
22	7S06	Nut M16	20
23	CR560035	Conical Gasket	1
24	8S06L	Bolt M16 x 75	12
25	CR520174	Star Shaft	1
26	CR531827	Adjusting Screw M16 x 70 (Can use 11S06M)	3
27	CR210236	Mixing Star	1
28	CR330062	Spring	3
29	CR630305	Star Shaft Spacer	1
30	CR320036	Key Gib Head 3/4" x 6" Long	1
31	7S06	Nut M16	3
32	CR210123	Star Blade Wearing Piece, obsolete use item 32 below	
32	CR21100169	Star Blade Wearing Piece	3
33	CR210007	Star Blade Holder, Cast	3
33A	CR210007P	Star Blade, Polyuerathane Alternative	3
33B	CR210007SS	Star Blade, Stainless Steel	3
34	8S04L	Bolt M10 x 75	3
35	CR660008	Bush	3
36	CR520118	Star Blade Finger c/w Lever	3
37	52S05L	Bolt Skt Csk Head M12 x 55	6
38	267S07	Washer Flat M12	6
39	59S04	Nut Nyloc M12	6
40	CR63100159	Collar	3
41	CR280008	1/4" BSP Angled Grease Nipple	3
42	10S04	Washer Flat 1/2"	1
43	CR570008	Rubber Washer 1/2"	1
44	CR530571	Grease Pipe	1
45	333104020	1/4" BSP Straight Grease Nipple	1
46	241902000	1/4" BSP Ferrule	1

# RP400 MIXING PAN ASSEMBLY

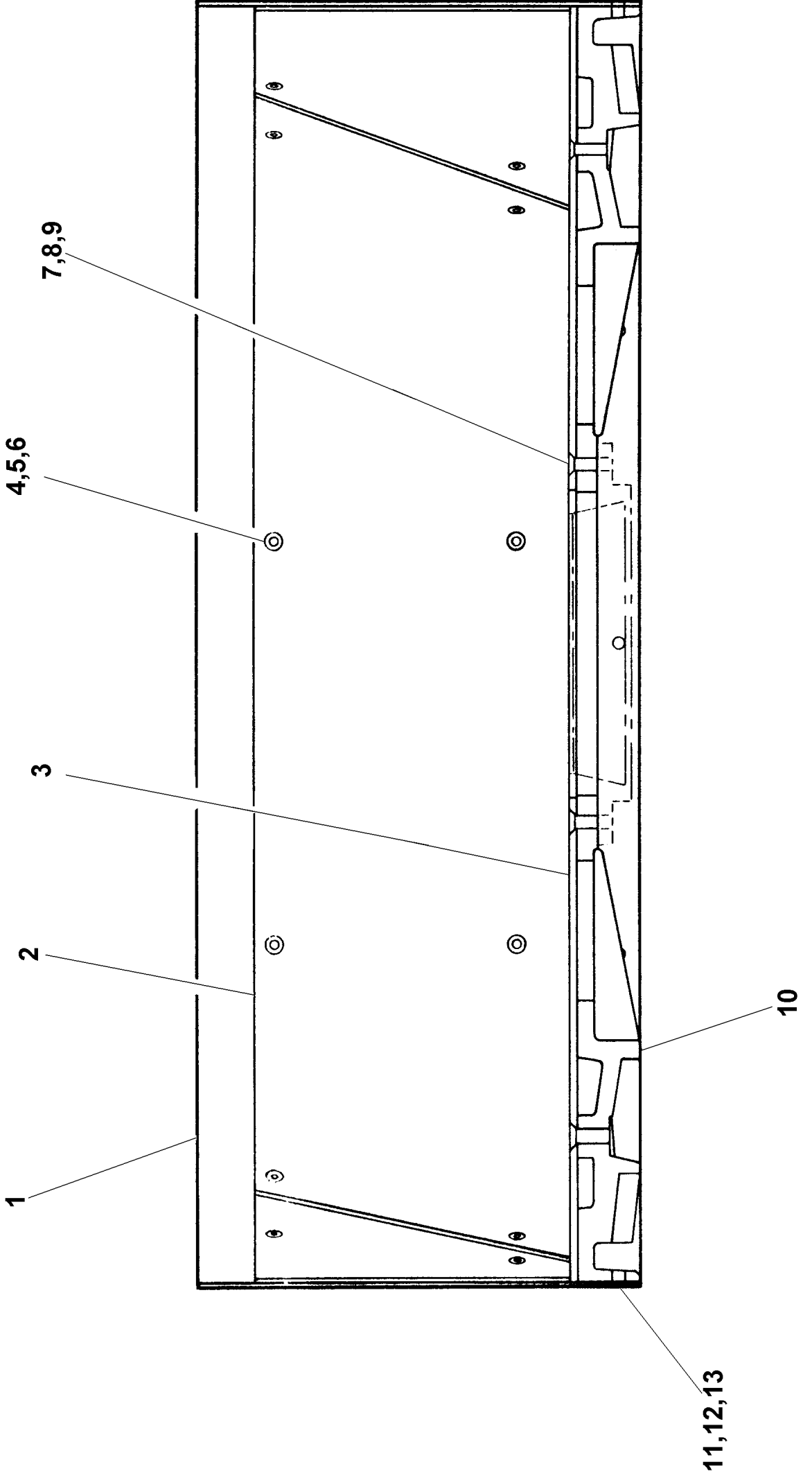

# RP400 MIXING PAN

1	CR54100152	Pan Rim	1
2	CR54100153	Pan Rim Wear Plates, Mild Steel	1x3
2	CR54100153H	Pan Rim Wear Plates, Wear Resistant Steel	1x3
2	CR51100153SS	Pan Rim Wear Plates, Stainless Steel	1x3
3	CR54100154	Pan Base Wear Plates, Mild Steel	1x4
3	CR54100154H	Pan Base Wear Plates, Wear Resistant Steel	1x4
3	CR54100154SS	Pan Base Wear Plates, Stainless Steel	1x4
4	52S04D	Screw Set Csk Skt Head M10 x 20	24
5	7S04	Nut M10	24
6	17S05	Spring Washer M10	24
7	52S06P	Screw Set Csk Skt Head M16 x 70	16
8	7S06	Nuts M16	16
9	17S08	Spring Washer M16	16
10	CR21100151	Pan Base	1
11	16S10G	Screw Set Slr Rnd Head M12 x 40	12
12	7S05	Nuts M12	12
13	17S06	Spring Washer M12	12



# RP400 MIXING PAN ROLLER ASSEMBLY

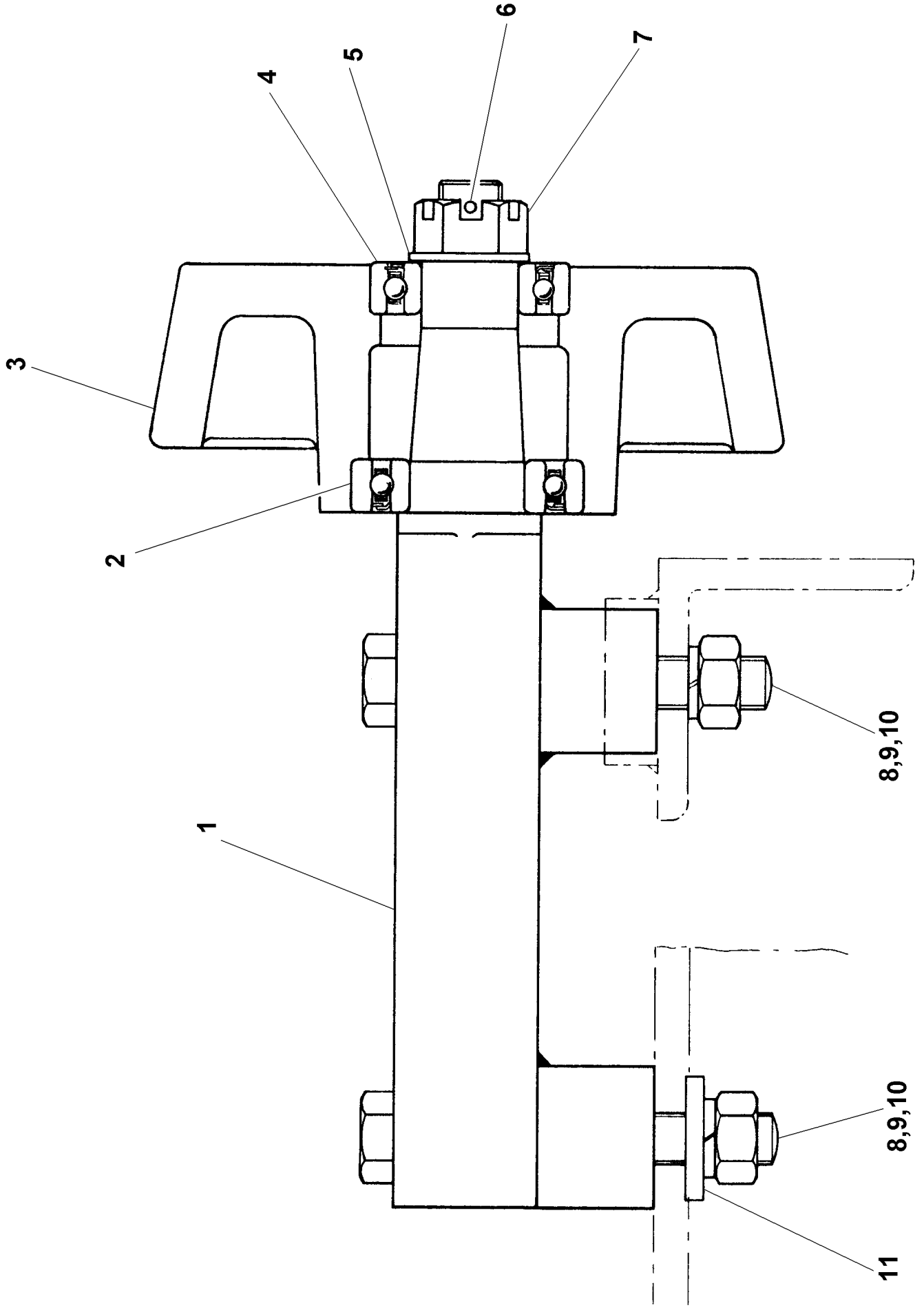

# RP400 MIXING PAN ROLLER

1	CR520104	Pan Roller Spindle (Obsolete use item 1 below)	
1	CR52100216	Pan Roller Spindle	4
2	88S17C	Sealed Ball Bearing	4
3	CR21100217	Pan Roller (Obsolete use Item 3 below)	
3	CR21100217	Pan Roller	4
4	88S016C	Sealed Ball Bearing	4
5	10S39	Washer 3/4"	4
6	44S05E	Split Pin 3/16" x 1 1/2"	4
7	77S07	Castelated Nut 3/4" B.S.W.	4
8	8S06R	Bolt M16 x 120	8
9	17S08	Spring Washer M16	4
10	7S06	Nut M16	8
11	105S07	Tapered Washer M16	4

# RP400 DISCHARGE CONTROL GEAR ASSEMBLY

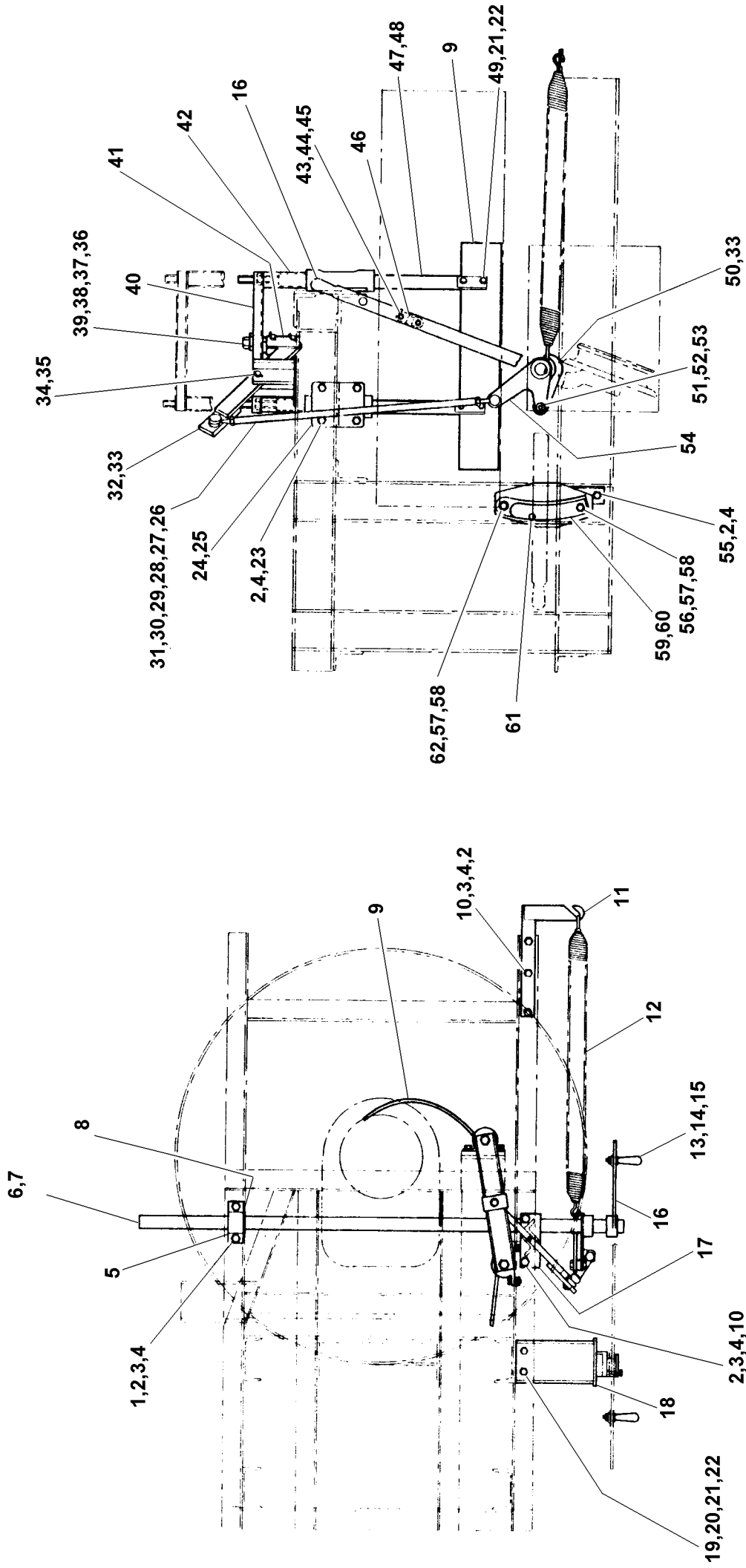

# RP400 DISCHARGE CONTROL GEAR

1	8S06F	Bolt M16 x 50	4
2	7S06	Nut	19
3	105S07	Taper Washer	9
4	17S08	Spring Washer	19
5	CR190011	Discharge Door Shaft Bearing	2
6	CR520120	Discharge Door Shaft	1
7	CR320083	5/8" Gib Key Head	2
8	CR490043	Washer Flat x 1 3/4" Dia	2
9	CR540650	Discharge Blade, obsolete use item 9 below	
9	CR54100172	Discharge Blade, Mild Steel	1
9	CR54100172H	Discharge Blade, Wear Resistant Steel	1
9	CR54100172SS	Discharge Blade, Stainless Steel	1
10	11S06F	Screw Set M16 x 40	5
11	CR260412	Discharge Blade Spring Anchor	1
12	CR330047	Discharge Door Control Spring	1
13	CR520109	Discharge Lever Handle	1
14	253S05	Nut 1/2" B.S.W.	1
15	41S07	Spring Washer 1/2"	1
16	CR260198	Discharge Door Lever	1
17	CR260402	Hinge Bracket	1
18	CR260455	Rack Support Bracket	1
19	11S05E	Screw Set M12 x 35	2
20	105S05	Tapered Washer M12	2
21	17S06	Spring Washer M12	6
22	7S05	Nut M12	6
23	8S06E	Bolt M16 X 45	8
24	CR210113	Finger Brackets	2
25	333104020	1/4" B.S.P. Grease Nipple	2
26	CR030072	Discharge Blade Control Rod	1
27	CR140004	L.H. Ball Joint	1
28	CR140005	R.H. Ball Joint	1
29	CR241648	Checknut - R.H. Thread 3/8" B.S.P.	1
30	CR241657	Checknut - L.H. Thread 3/8" B.S.P.	1
31	131S02	1/8" B.S.P. Angled Grease Nipple	2
32	CR260403	Discharge Blade Lifting Lever	1
33	131S01	1/8" B.S.P. Straight Grease Nipple	2
34	CR520112	Pin	3
35	CR520164	Locking Pins	3
36	CR520148	Bridge Hinge	1
37	333601010	1/8" Gas Angled Grease Nipple	1
38	253S09	Nut 1" B.S.W.	1
39	41S13	Spring Washer 1"	1
40	CR260404	Finger Bridge	1
41	CR530478	Discharge Blade Lifting Links	2
42	CR531998	Pipe Stops	2
43	52S04G	Screw Set Csk Skt Head M10 x 35	2
44	7S04	Nut M10	2
45	17S05	Spring Washer M10	2
46	CR210098	Pawl	1
47	CR520111	Discharge Blade Finger	2
48	253S08	Nut 7/8" B.S.W.	4
49	52S05K	Screw Set Csk Skt Head M12 x 50	4

# RP400 DISCHARGE CONTROL GEAR

50	CR260395	Discharge Door Control Spring Hook	1
51	8S18J	Bolt M18 X 65	1
52	7S16	Nut M18	1
53	17S15	Spring Washer M18	1
54	CR260411	Discharge Door Shaft Lever	1
55	11S06E	Screw Set M16 x 35	2
56	8S06K	Bolt M16 x 70	1
57	59S11	Nyloc Nut M16	2
58	267S09	Washer Flat M16	2
59	CR210158	Discharge Door Rack	1
60	CR210159	Discharge Door Keep	1
61	CR520173	Handle Rack Pin	1
62	52S06J	Screw Set Csk Skt Head M16 x 45	1

# RP400 DISCHARGE DOOR ASSEMBLY

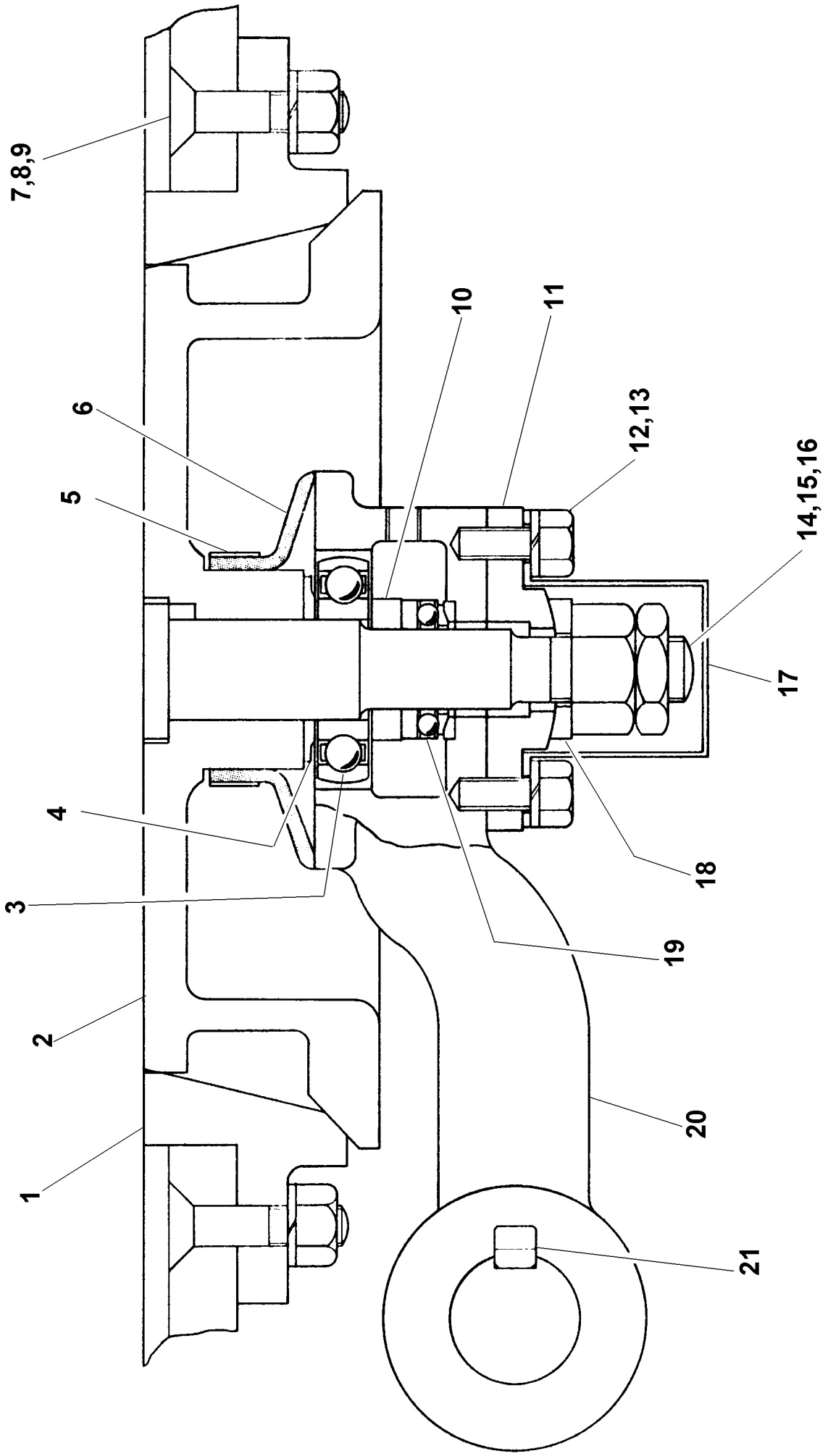

# RP400 DISCHARGE DOOR

1	CR21100180	Door Seating, Mild Steel	1
1	CR21100180SS	Door Seating, Stainless Steel	1
2	CR21100179	Door	1
3	CR150423	Self Aligning Ball Bearing	1
4	CR630387A	Thrust Washer	1
5	97S15	Hose Clip 70-89MM	1
6	CR570017	Rubber Seal	1
7	25S06P	Screw Set Csk Skt M16 x 70	8
8	7S06	Nut M16	8
9	17S08	Spring Washer M16	9
10	CR630387B	Distance Piece	1
11	CR210093	Door Arm Bottom Cover	1
12	11S05E	Set Screw M12 x 35	4
13	17S06	Spring Washer M12	4
14	CR52100182	Door Spindle	1
15	7S08	Nut M24	1
16	56S08	Nut Half M24	1
17	CR540451	Pan Door Pin Nut Cover	1
18	CR49100187	Bottom Cover Washer	1
19	CR150347	Single Thrust Ball Bearing & Seating	1
20	CR210127	Door Arm	1
21	CR320030	5/8" Gib Head Key 6" Long	1
*	CR54100203	Discharge Chute	1
*	11S04C	Screw Set M10 x 25	4
*	267S06	Washer Flat M10	4
*	56S03	Nyloc Nut M10	4

\* Not illustrated

# RP400 DISCHARGE DOOR AIR CYLINDER

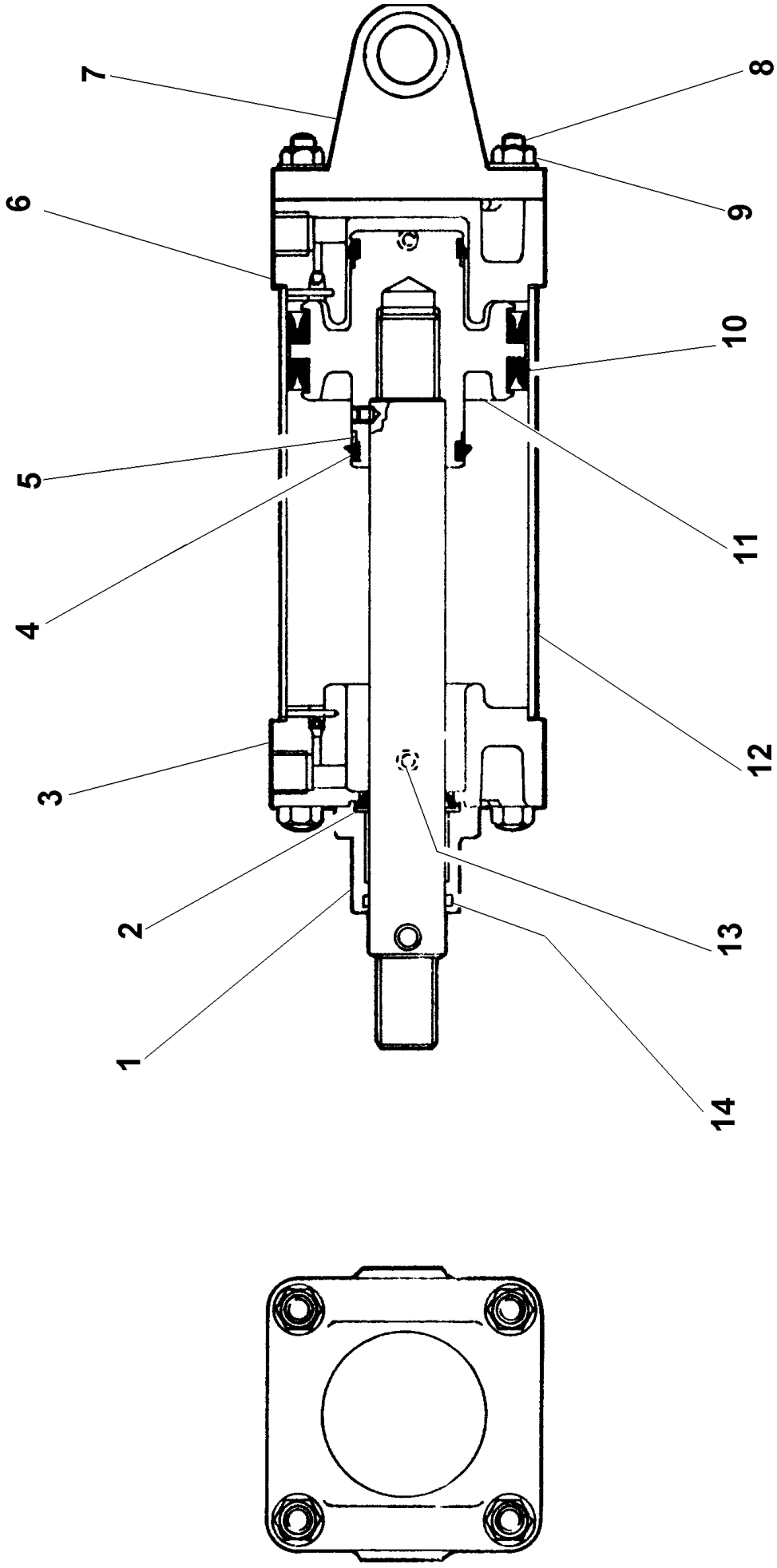



# RP400 DISCHARGE DOOR AIR CYLINDER

	CR110298	Air Cylinder Assembly Complete	1
	CR110325	Seal Kit for above	1
1	CR110336	Bearing Assembly	1
2	CR110337	Piston Rod Packing	1
3	CR110338	Front End Cover Assembly	1
4	CR110339	Cushion Seal	2
5	CR110340	Cushion SealRetaining Ring	2
6	CR110342	Rear End Cover Assembly	1
7	CR110349	Rear Clevis Mounting	1
8	CR110344	Tie Rod	4
9	CR110343	Tie Rod Nut	8
10	CR110346	Piston Seal	2
11	CR110341	Piston & Piston Rod Assembly	1
12	CR110347	Barrel	1
13	CR110348	O' Ring	2
14	CR110345	Wiper Seal	1

# RP400 DISCHARGE DOOR PNEUMATIC CONTROLS

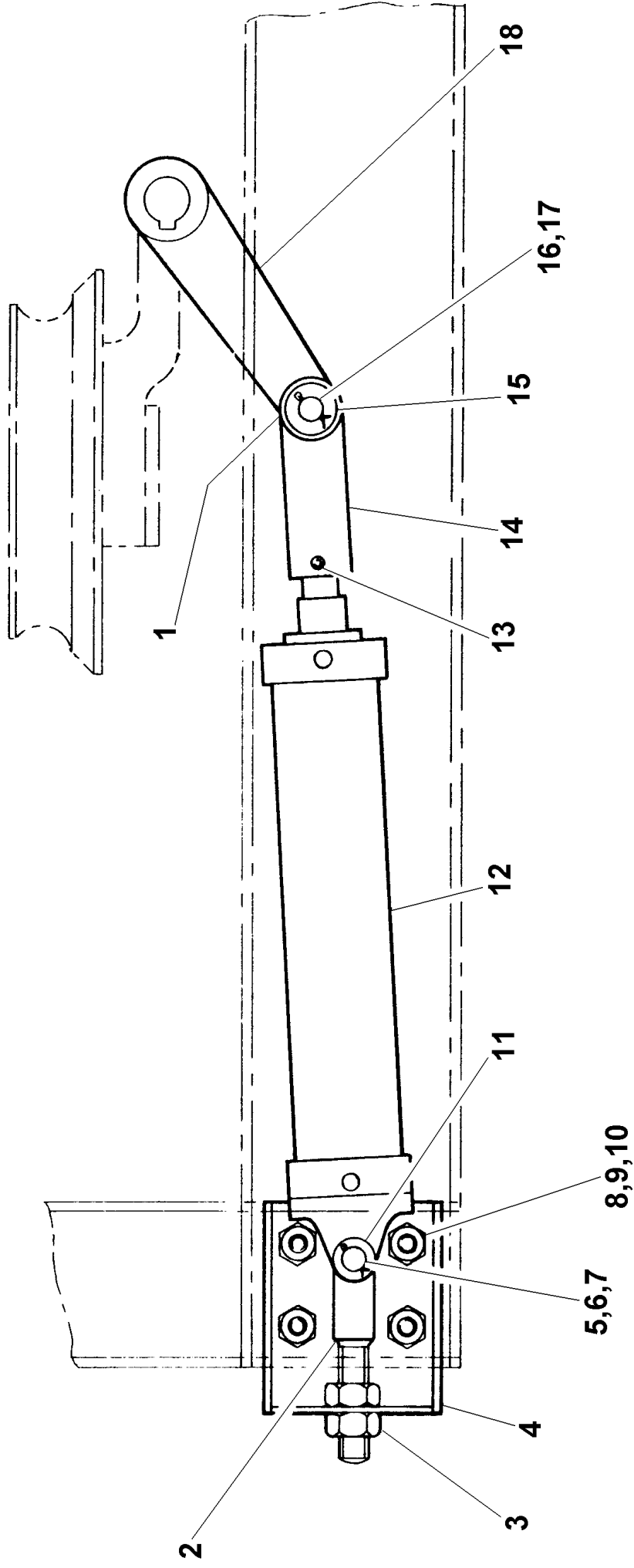

# RP400 DISCHARGE DOOR PNEUMATIC CONTROLS

1	CR280003	Grease Nipple	1
2	CR532214	Cylinder Pivot Holder	1
3	7S08	Nut M24	2
4	CR541854	Bracket	1
5	CR520441	Cylinder Pivot Pin	1
6	CR630075	Spacer	2
7	44S18J	Split Pin M6 x 40	2
8	11S06E	Screw Set M16 x 35	4
9	7S06	Nut M16	4
10	17S08	Spring Washer M16	4
11	10S07	Washer Flat 7/8"	2
12	CR110298	Air Cylinder	1
12A	CR110325	Seal Kit for above Cylinder	1
12B	CR119369	Air Cylinder Alternative to Item 12 Used with Item 12C	1
12C	CR119370	Magnetic Reed Switch Used With Item 12B Not Illus	2
13	185S04C1	Grub Screw 3/8" B.S.W. x 3/8" Long	1
14	CR260532	Lever Pivot Holder Use With Item 12	1
14A	CR26100842	Lever Pivot Holder Use with Item 12C	1
15	10S41	Washer Flat 1"	2
16	CR520191	Lever Pivot Pin	1
17	44S05E	Split Pin 3/16" x 1 1/2"	2
18	CR260750	Discharge Door Shaft Lever	1
18A	CR320030	Key Gib Head 5/8" x 6" (not illustrated)	1

# RP400 FIXED BLADE ASSEMBLY

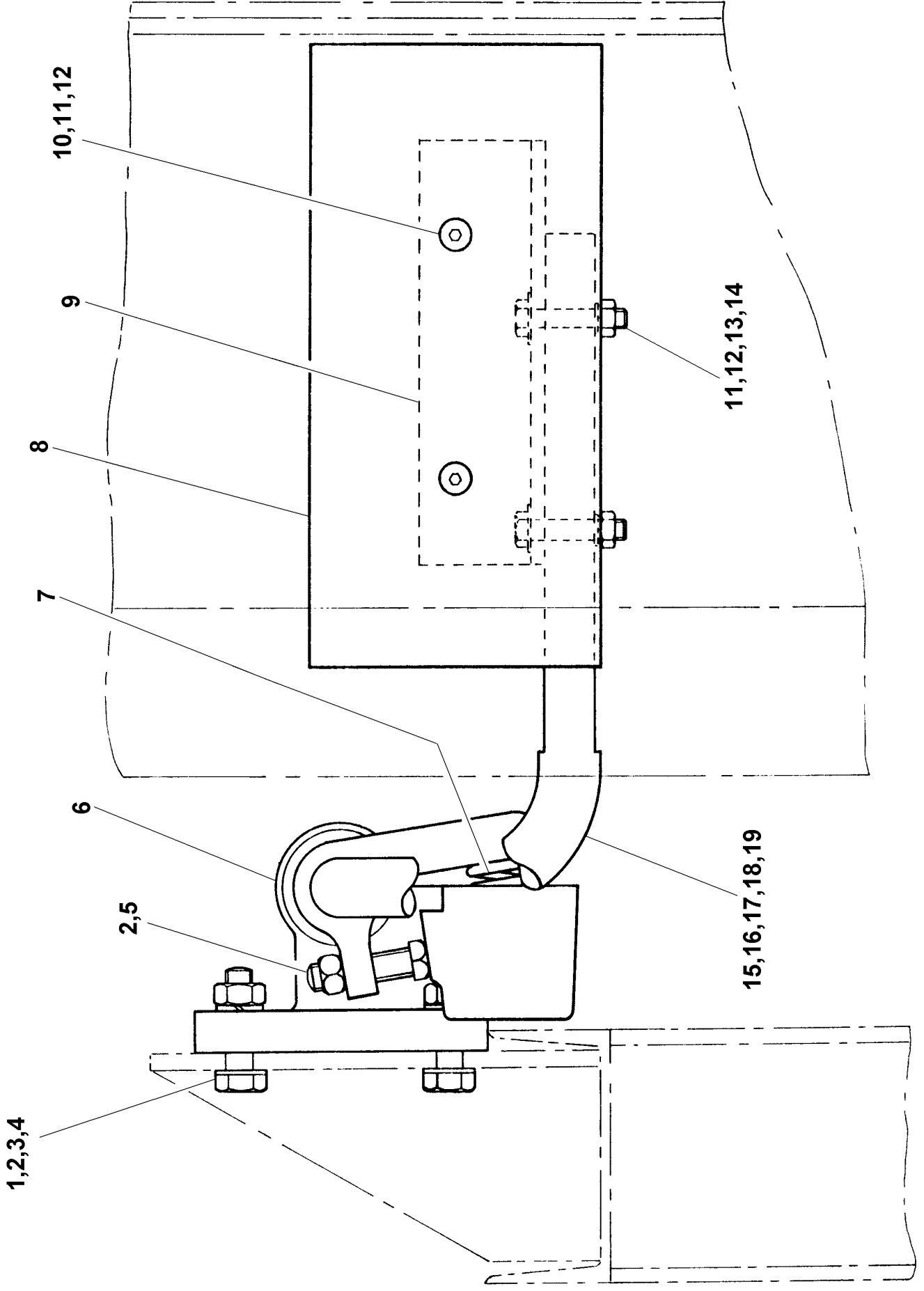

## RP400 FIXED BLADE

1	8S06F	Bolt M16 x 50	2
2	7S06	Nut M16	3
3	267S09	Washer Flat M16	2
4	17S08	Spring Washer M16	2
5	CR531827	Adjusting Bolt M16 (Special)	1
6	CR210102	Fixed Blade Spring Box	1
7	CR330063	Spring	1
8	CR530490	Fixed Blade, Mild Steel	1
8	CR530490H	Fixed Blade, Wear Resistant Steel	1
8	CR530490SS	Fixed Blade, Stainless Steel	1
9	CR530491	Fixed Blade Angle, Mild Steel	1
9	CR530491SS	Fixed Blade Angle, Stainless Steel	1
10	52S05J	Screw Set Csk Skt M12 x 45	2
11	7S05	Nut 12	4
12	17S06	Spring Washer M12	4
13	8S05J	Bolt M12 x 65	2
14	267S07	Washer Flat M12	2
15	CR030066A	Finger Fixed Blade (Obsolete use Item 15 Below)	
15	CR53100199	Finger Fixed Blade, Mild Steel	1
15	CR53100199SS	Finger Fixed Blade, Stainless Steel	1
16*	CR630109	Collar (Obsolete use Item 16 Below)	
16*	CR63100159	Collar	1
17*	8S04K	Bolt M10 x 70	1
18*	61S04	Nut Binx M10	1
19*	267S06	Washer Flat M10	1

\* Not illustrated

# RP400 FORKED BLADE ARRANGEMENT

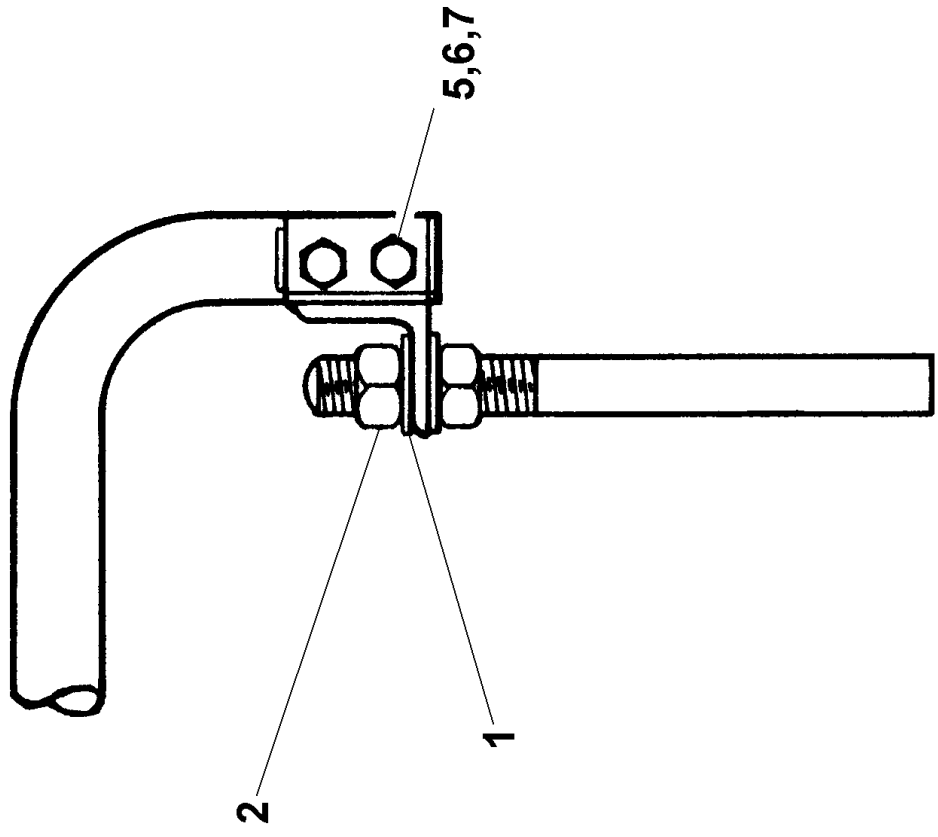
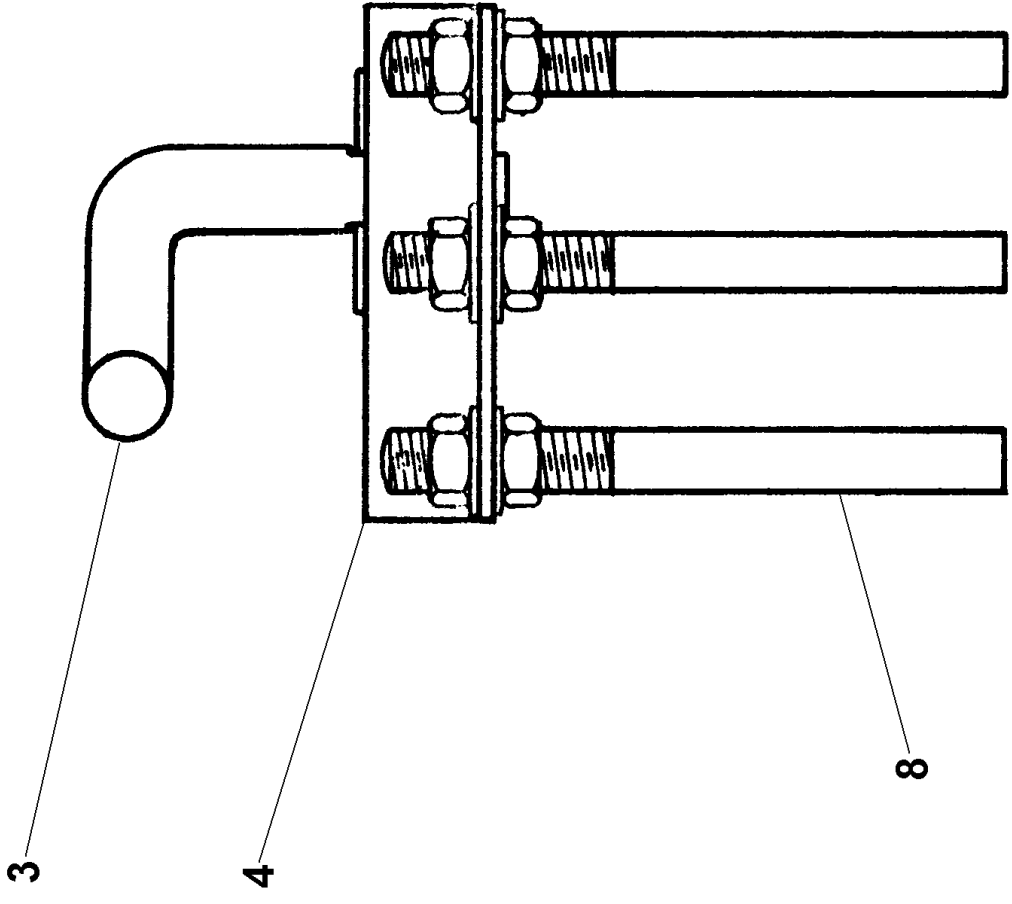

# RP400 FORKED BLADE ARRANGEMENT

1	7S08	Spring Washer M24	6
2	7S08	Nut M24	6
3*	CR531323	Finger for Forked Blade	1
4	CR531324	Forked Blade Finger Bridge	1
5	8S05H	Bolt M12 x 60	2
6	7S06	Nut M16	2
7	17S06	Spring Washer M12	2
8	CR530637	Fork Tine	3

\*This finger is only used when forked blades replace the lower mixing blades

**NOTE:-** Quantities given are for one blade unit, items should be ordered according to the number of Forked Blade units required

# RP400 GUARDS & PANELS ASSEMBLY

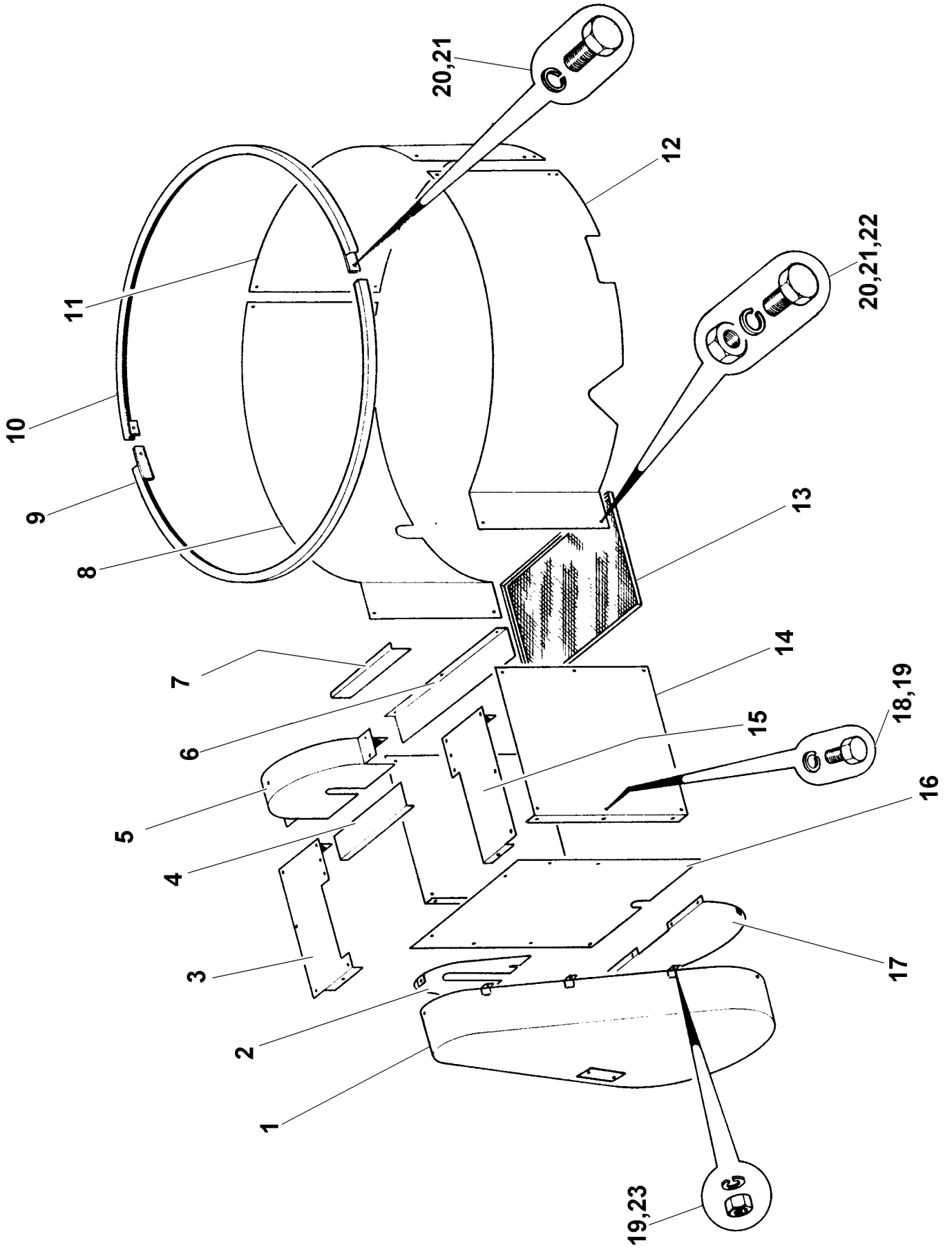



# RP400 GUARDS

1	CR541845	Vee Belt Guard	1
2	CR541846	Vee Pulley Back Guard	1
3	CR541841	Top Guard (Fixed Blade Side)	1
4	CR541855	Motor To Chain Guard	1
5	CR541844	Top Chainwheel Guard	1
6	CR541852	Front Guard	1
7	CR541853	Bearing Support Guard	1
8	CR030266A	Pan Guard	1
9	CR030266D	Pan Guard	1
10	CR030266E	Pan Angle	1
11	CR030266C	Pan Guard	1
12	CR030266B	Pan Guard	1
13	CR541851	Bottom Guard	1
14	CR541939	Side Guard	2
15	CR541842	Top Guard (Discharge Gear Side)	1
16	CR541840	Back Guard	1
17	CR541847	Pulley Bottom Guard	1
18	11S03A	Screw Set M8 x 16	76
19	17S04	Spring Washer M8	76
19A	267S05	Washer Flat M8	76
20	11S04B	Screw Set M10 x 20	6
21	17S05	Spring Washer M10	6
22	7S04	Nut M10	4
23	7S03	Nut M8	6
24	CR261360	Chassis Lower (Not Illustrated)	1

**RP400 DRIVE CHAIN OIL LUBRICATOR**

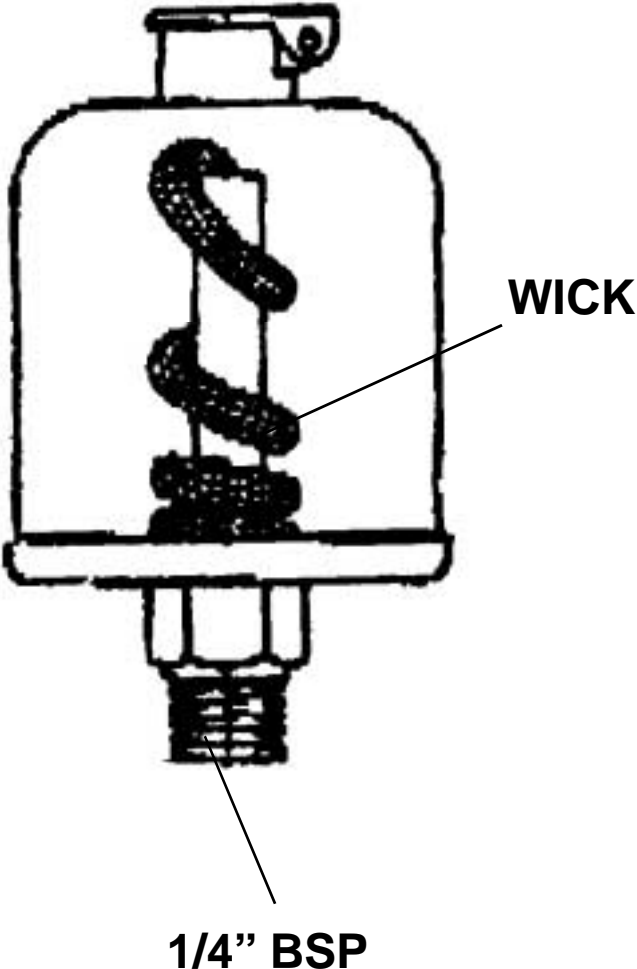

# RP400 DRIVE CHAIN OIL LUBRICATOR

1 CR280035 Drive Chain Oil Lubricator

1

# RP400 PAN SEALING STRIP (EARLY TYPE)

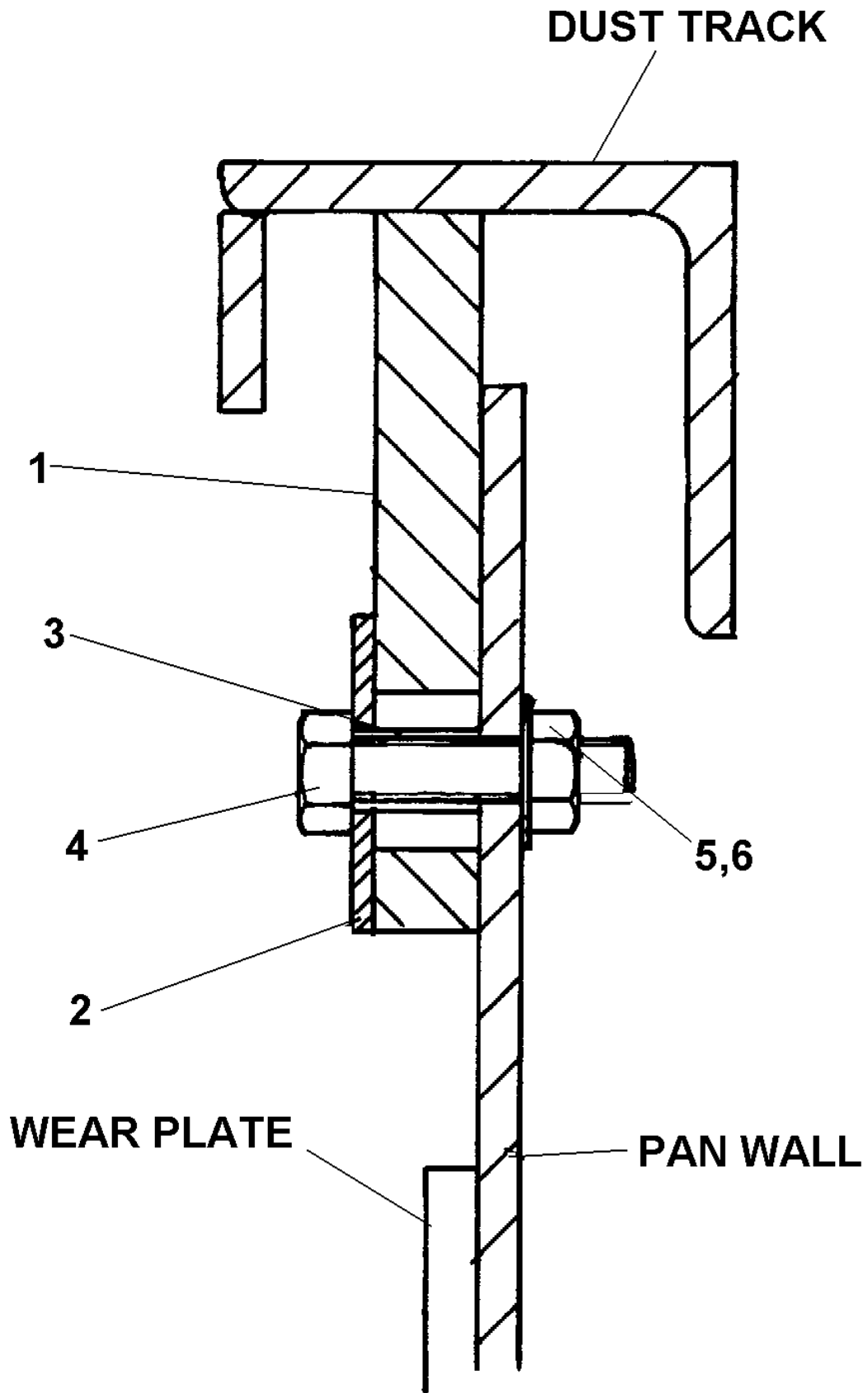

## RP400 PAN SEALING STRIP (EARLY TYPE)

1	CR479005	Pan Sealing Rubber	4
2	CR539124	Holding Plate	4
3	CR529035	Spacer	16
4	11S03D	Screw set M8 x 30	16
5	61S03	Nut Binx M8	16
6	267S05	Washer Flat M8	16

**RP400 PAN SEALING & REAR COVER  
LATER TYPE AS MC NO 6048**

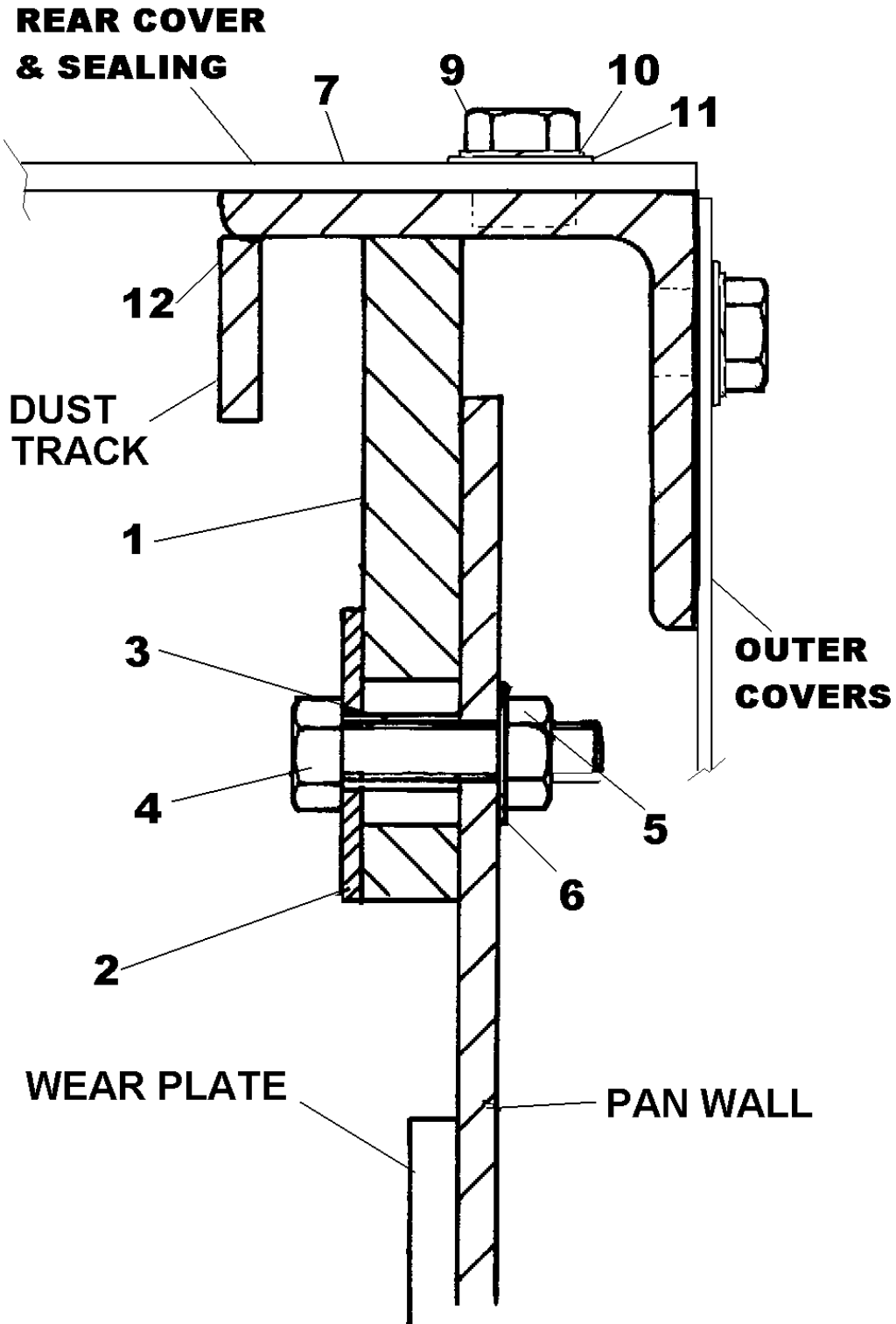

**RP400 PAN SEALING & REAR COVER  
(LATER TYPE AS MC NO 6048)**

1	CR479005	Pan Sealing Rubber	4
2	CR539124	Retaining Plate	4
3	CR529035	Spacer	16
4	11S03D	Screw Set M8 x 30	16
5	61S03	Nut Binx M8	16
6	267S05	Washer Flat M8	16
7	CR549200	Pan Sealing & Rear Cover Assembly	1

Comprises 8 Separate Covers Below:-

7A	CR549200A	Cover	1
7B	CR549200B	Cover	1
7C	CR549200C	Cover	1
7D	CR549200D	Cover	1
7E	CR549200E	Cover	1
7F	CR549200F	Cover	1
7G	CR549200G	Cover	1
7H	CR549200H	Cover	1

Rear Cover CR549200 Retained By:-

9	11S03B	Screw Set M8 x 20	6
9A	11S03C	Screw Set M8 x 25	9
10	17S04	Washer Spring M8	15
11	267S05	Washer Flat M8	15
12	CR030266D/E	Pan Dust Track (Front & Rear Halves)	1

The following Overcentre Catches are not illustrated

13	10537A02	Catch Toggle Overcentre	4
13A	10538A02	Plate Fastener	4
14	11S01AA	Screw Set M5 x 16	16
15	17S02	Washer Spring M5	16
16	267S03	Washer Flat M5	16
17	7S01	Nut M5	16

# RP400 DECALS AND LOGOS

## 1 CROKER CUMFLOW RP400

<b>WINGET</b>		WINGET LIMITED 200, Bury Street, Bury, Lancs BL9 9DW Tel: 01256 351111 Fax: 01256 351112	
Model	_____		
Serial No.	_____		
Engine No.	_____		
Capacity	Mass (kg)	_____	
SRO No.	Power (kW)	_____	
Year Of Manuf.	Eng. (rpm)	Drum (rpm)	_____

2

**WINGET**

4



5



6



7

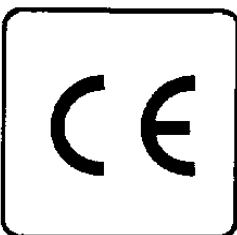

8

9

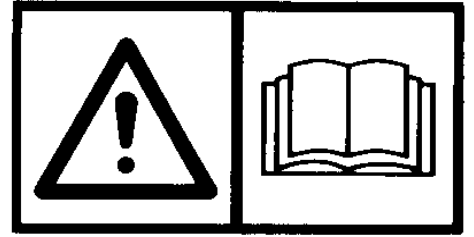

10



11



12

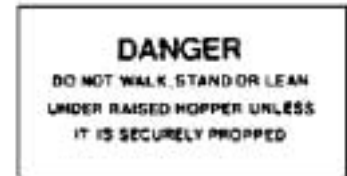

13

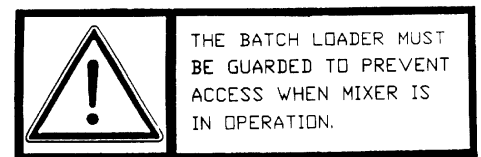

14

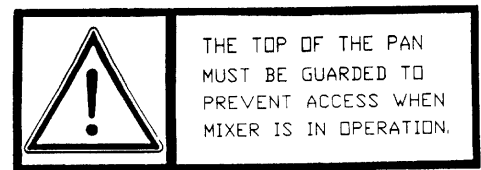



# RP400 DECALS AND LOGOS

1	CR85100765	Decal RP400	3
2	V2003037	Plate Serial Number	1
3	101S05D	Rivet Pop	4
4	V2003039	Decal WINGET Medium	3
5	V2003665	Decal Sling Point	4
6	V2003598	Decal British Made	3
7	V2004307	Decal Electrical Hazard	5
8	V2004223	Decal CE Mark	1
9	V2004229	Decal Operators Handbook	3
10	V2004744	Decal Eye Protection	3
11	504694600	Decal Safety	3
12	513331600	Decal Danger	8
13	CR85100771	Decal Batch Loader Guarding	2
14	CR85100772	Decal Pan Guarding	2

**OPERATING  
AND  
MAINTENANCE MANUAL**

**SECTION 5**

**ANCILLARY EQUIPMENT  
SPARE PARTS**

# RP400 LOADER CHASSIS ASSEMBLY

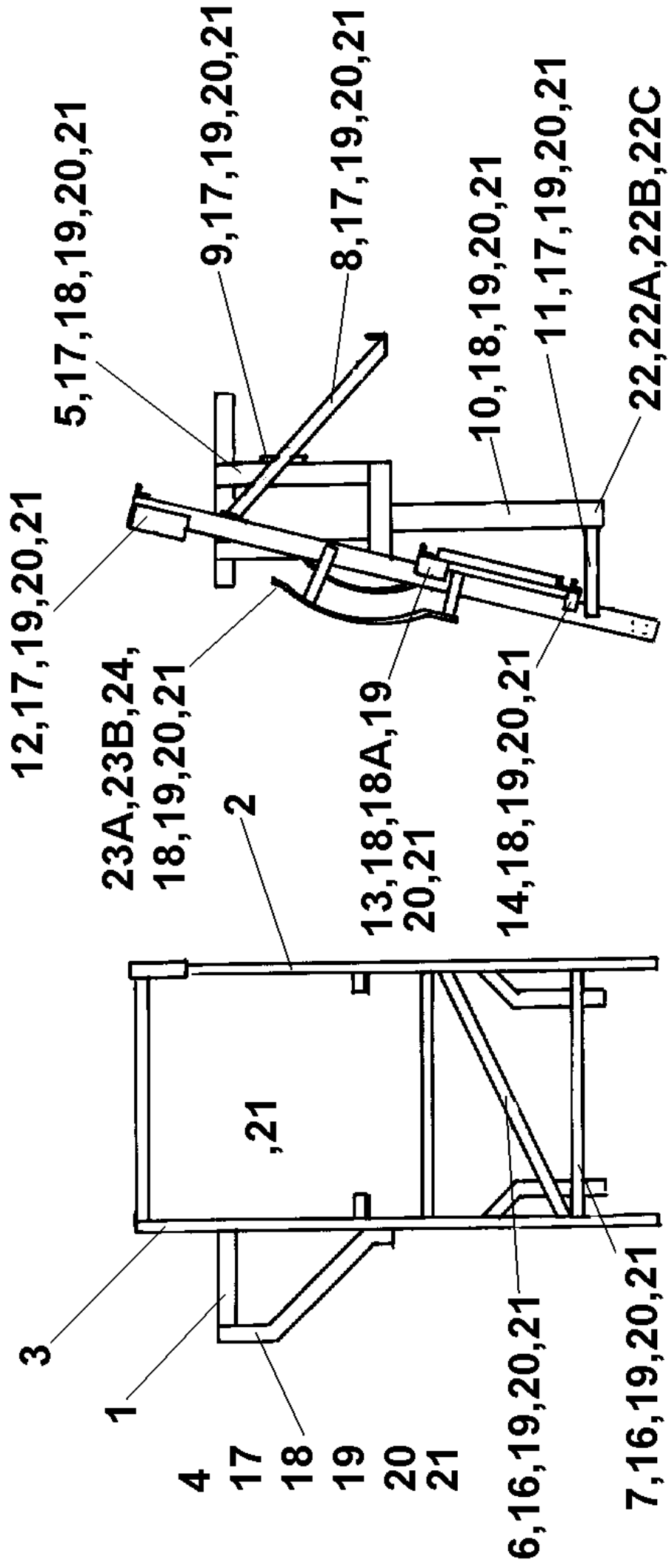

# RP400 LOADER CHASSIS ASSEMBLY

1		Bedplate Winch Unit	1
2	CR269108	Runway, Loader R.H.	1
3	CR269109	Runway, Loader L.H.	1
4	CR539088	Support Angle, Winch Unit Bedplate	2
5	CR539089	Channel Bedplate Support	1
6	CR539090	Brace Diagonal	1
7	CR539091	Brace Horizontal	3
8	CR26100312	Tie Beam, Long	1
9	CR26100313	Tie Beam, Short	1
10	CR53100314	Channel, Runway Support	2
11	CR53100288	Lower Tie Bracket	2
12	CR532191	Plummer Block Bearing Support Angle	1
13	CR532244	Cleat Bracing Support Bracket	2
14	CR532245	Bracing Angle Support Bracket	2
16	8S05B	Bolt M12 x 30	8
17	8S05C	Bolt M12 x 35	28
18	52S05G	Bolt C/Sunk M12 x 35	28
18A	52S05K	Bolt C/Sunk M12 x 50	2
19	7S05	Nut M12	66
20	17S06	Washer Spring M12	66
21	267S07	Washer Flat M12	66
22	8S06F	Bolt M16 x 50	10
22A	17S08	Washer Spring M16	10
22B	267S09	Washer Flat M16	10
22C	7S06	Nut M16	10
23A	CR531003691	Guide Rail L.H.	2
23B	CR531003692	Guide Rail R.H.	2
24	CR53100368	Packing, Guide Rail	4

# RP400 LOADER HOPPER & LIMIT SWITCHES

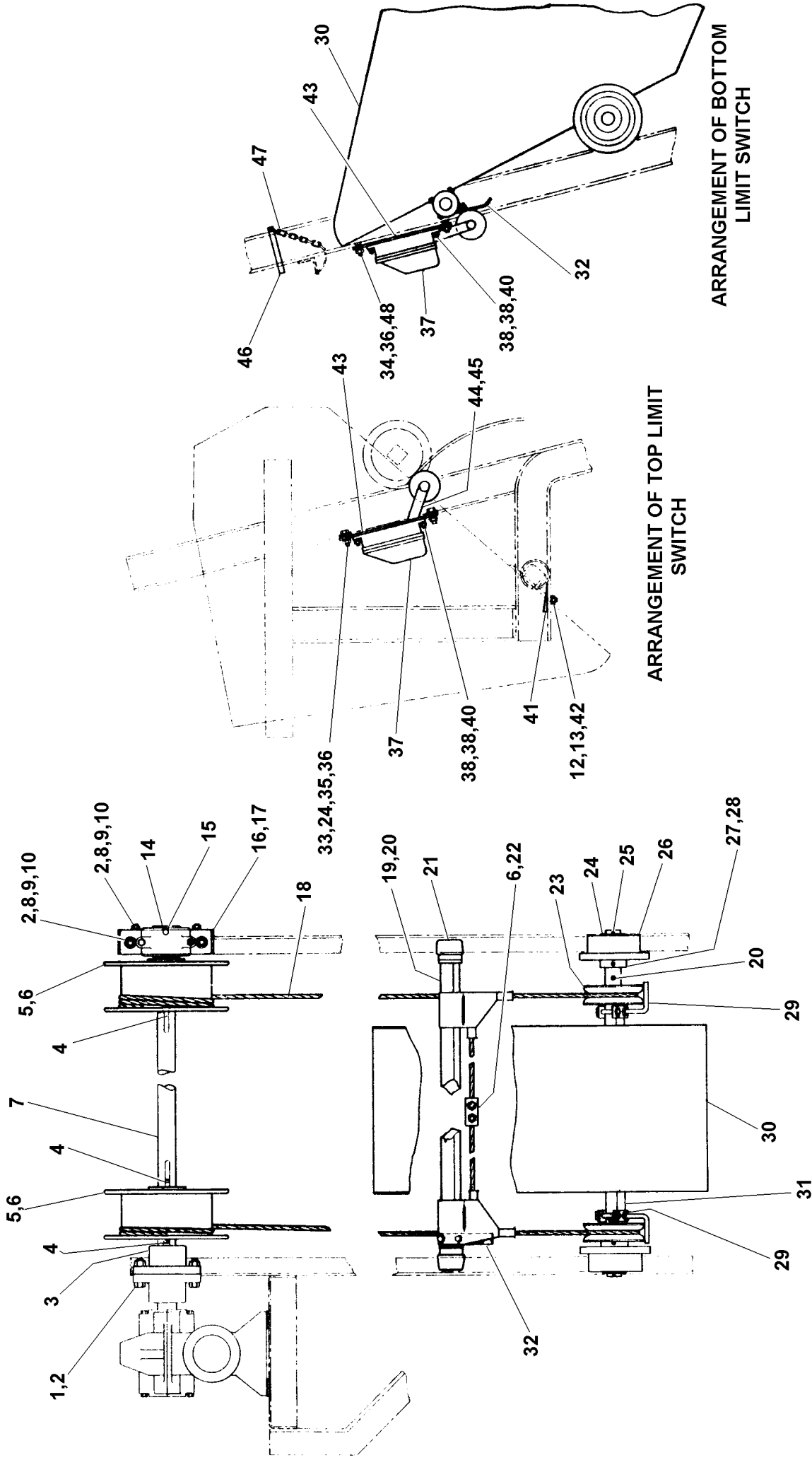

# RP400 ELECTRIC LOADER - HOPPER & LIMIT SWITCHES

1	8S06J	Bolt M16 x 65	6
2	59S11	Nyloc Nut M16	8
3	CR210189	Rope Drum Shaft Coupling	1
4	CR320020	1/2" Gib Head Key 5" LG	3
5	CR210191	Rope Drum	2
6	CR243033	Rope Anchor Bolts	6
7	CR520416	Top Rope Drum Shaft	1
8	8S06G	Bolt M16 x 55	2
9	105S07	Tapered Washer M16	2
10	267S09	Washer Flat M16	2
11	8S05E	Bolt M12 x 45	2
12	7S05	Nut M12	4
13	17S06	Spring Washer M12	4
14	CR150884	P Series Plummer Block 2"	1
15	333601010	1/8" B.S.P. Grease Nipple	1
16	CR532191	Plummer Block Support	1
17	CR532192	Packing	1
18	section 35	10mm Diameter Rope Length to Suit Installation	
19	CR520143A	Front Axle C/W Rope Pipe Bends	1
20	333104020	1/4" B.S.P. Grease Nipple	4
21	CR530896	Front Axle Roller	2
22	CR530692	Rope Retainer Block	1
23	CR210192	Hopper Rope Pulley	2
24	10S43	Washer Flat 1 1/2" Dia	2
25	44S05G	Pin Split 3/16" x 2"	2
26	CR210157	Rear Axle Roller	2
27	CR630209	Collar	2
28	185S04C1	Grub Screw 3/8 B.S.W. x 3/8" Long	2
29	CR091036	Hopper Rope Guide	2
30	CR540756	Loading Hopper	1
31	CR520143C	Rear Axle	1
32	CR261502	Limit Switch Striking Plate & Clamp	1
33	8S05D	Bolt M12 x 40	2
34	59S04	Nyloc Nut M12	4
35	105S05	Tapered Washer M12	2
36	267S07	Washer Flat M12	4
37	CR220005	Limit Switch (Obsolete use Item 37 Below)	
37	CR229083	Limit Switch	2
38	52S04G	Screw Set Csk Skt Head M10 x 35	4
39	267S06	Washer Flat M10	4
40	59S03	Nyloc Nut M10	4
41	CR080714	Loading Hopper Stop	2
42	52S05F	Screw Set Csk Skt Head M12 x 30	2
43	CR530450	Limit Switch Mounting Plate	2
44	CR220100	Limit Switch Arm Complete With Roller	2
45	401100503	5/16" BSF x 3/8" Grub Screw For Switch Arm	4
46	CR530968	Hopper Stop Pin (See Item 47A)	
47	CR600005	Hopper Stop Pin Chain (See Item 47A)	
47A	CR530062	Hopper Stop Chain & Pin Assembly	2
48	52S05F	Screw Set Csk Skt Head M12 x 30	2
49	CR531003691	Guide Rail LH (Not Illustrated)	1
50	CR531003692	Guide Rail RH (Not Illustrated)	1

# RP400 WINCH UNIT ASSEMBLY

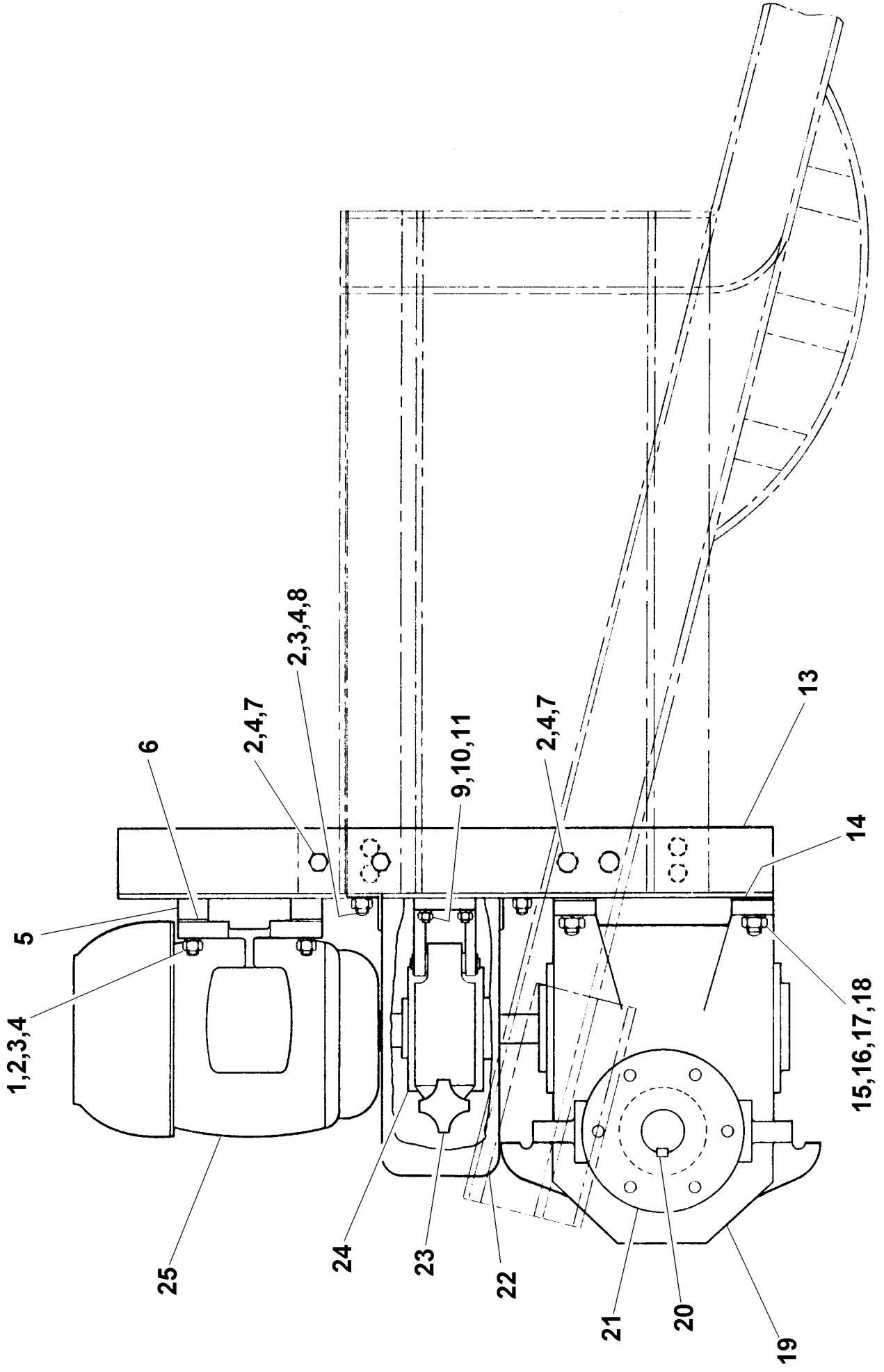

# RP400 LOADER HOISTING UNIT

1	8S05L	Bolt M12 x 75	4
2	7S05	Nut M12	14
3	267S07	Washer Flat M12	6
4	17S06	Spring Washer M12	14
5	CR530894	Packing	4
6	CR530893	Packing	4
7	8S05B	Bolt M12 x 30	6
8	11S05C	Bolt M12 x 25	2
9	8S04E	Bolt M10 x 45	4
10	7S04	Nut M10	4
11	17S05	Spring Washer M10	4
12	52S04F	Bolt Csk Skt Head M12 x 30	2
13	CR540522	Hoisting Unit Bedplate	1
14	CR530892	Packing	4
15	8S06J	Bolt M16 x 65	4
16	7S06	Nut M16	4
17	17S08	Spring Washer M16	4
18	267S09	Washer Flat M16	4
19	CR679000	Reduction Gear	1
20	CR320020	Key Gib Head 9/16" x 5" Long	1
21	CR210190	Reduction Gear Coupling	1
22	CR540537	Magnetic Brake Guard	1
23	CR550114	Dewhurst 6" Diameter Magnetic Brake	1
24	CR210188	Drum, Magnetic Brake Assembly	1
25	CR229014	4 KW Electric Motor (Obsolete use Item 25 Below)	
25	CR229014	4 KW Electric Motor D132M	1
*	CR220074	Coil }	1
*	CR551423	Brake Lining Kit c/w screws} Used with Item 23	1 set
*	CR551424	Brake Lining Screws }	12

\* Not illustrated

If the Brake Unit fitted to your machine is not a 'Dewhurst' unit please quote make, model and serial number when ordering replacement parts or brake shoes



# RP400 WORM REDUCTION GEARBOX

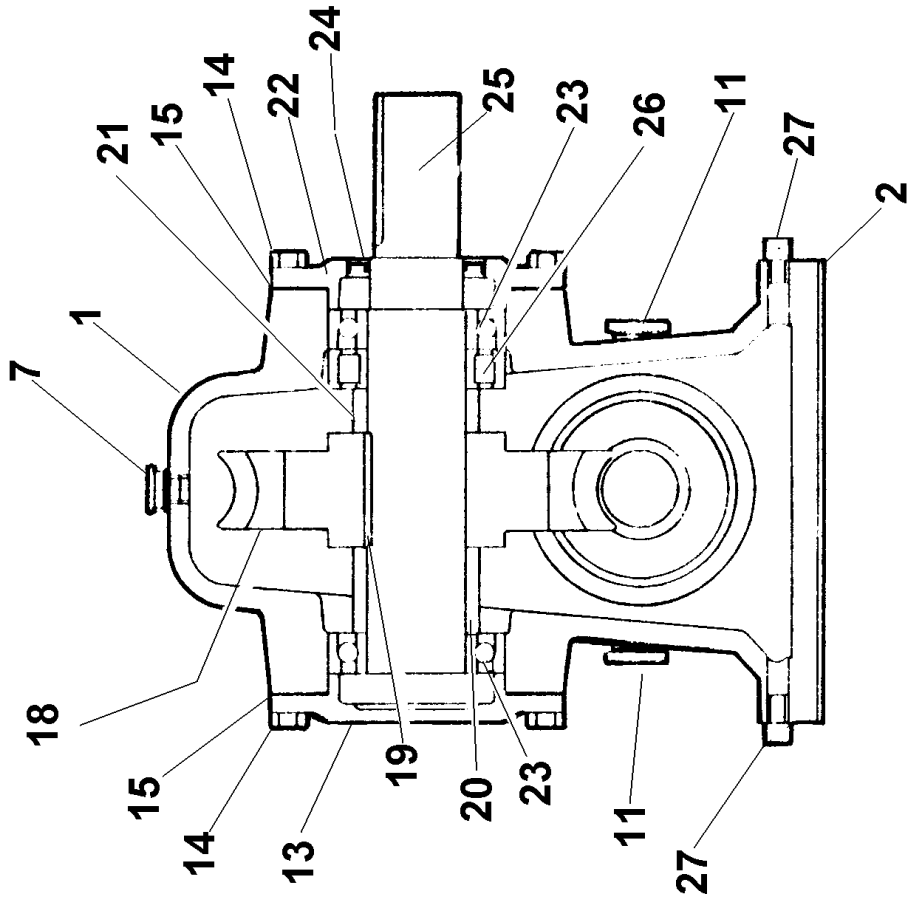
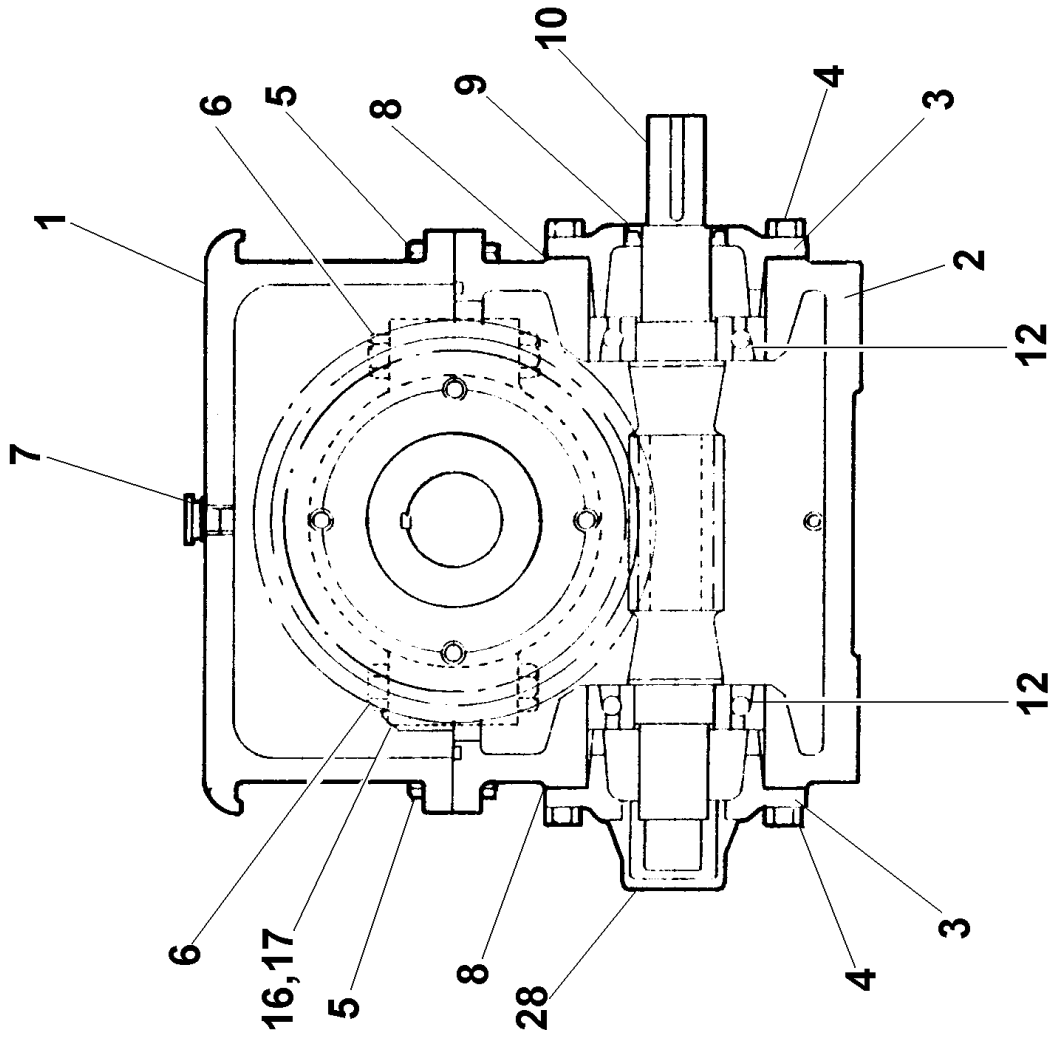

# RP400 WORM REDUCTION GEARBOX

*	CR080264	Gearbox Complete	1
1	CR670048	Gear Case Upper	1
2	CR670049	Gear Case Lower	1
3	CR670050	Worm Shaft End Cover	2
4	CR670051	Worm Shaft End Cover Screw	12
5	CR670052	Joint Flange Bolts	4
6	CR670053	Joint Boss Bolts	4
7	CR670054	Filler Plug and Washer	1
8	CR670055	Worm Shaft Shims	as reqd.
9	CR670056	Worm Shaft Oil Seals	1
10	CR670057	Worm Shaft	1
11	CR670058	Oil Level Plug and Washer	2
12	CR670059	Worm Shaft Bearing	2
13	CR670060	Wheel Shaft Blank End Cover	1
14	CR670061	End Cover Screws	6
15	CR670062	Wheel Shaft Shims	as reqd.
16	CR670063	Oil Collector Boxes	2
17	CR670064	Oil Collector Box Screws	4
18	CR670065	Worm Wheel	1
19	CR670066	Wheel Shaft Key	1
20	CR670067	Wheel Shaft Distance Piece	1
21	CR670068	Wheel Shaft Distance Piece	1
22	CR670069	Wheel Shaft End Cover	1
23	CR670070	Wheel Shaft Bearing	2
24	CR670071	Wheel Shaft Oil Seal	1
25	CR670072	Wheel Shaft	1
26	CR670073	Roller Bearings	1
27	CR670074	Oil Drain Plugs	2
28	CR670075	End Cap	1

Identify gearbox Make & Model before ordering parts

# RP400 WORM REDUCTION GEARBOX

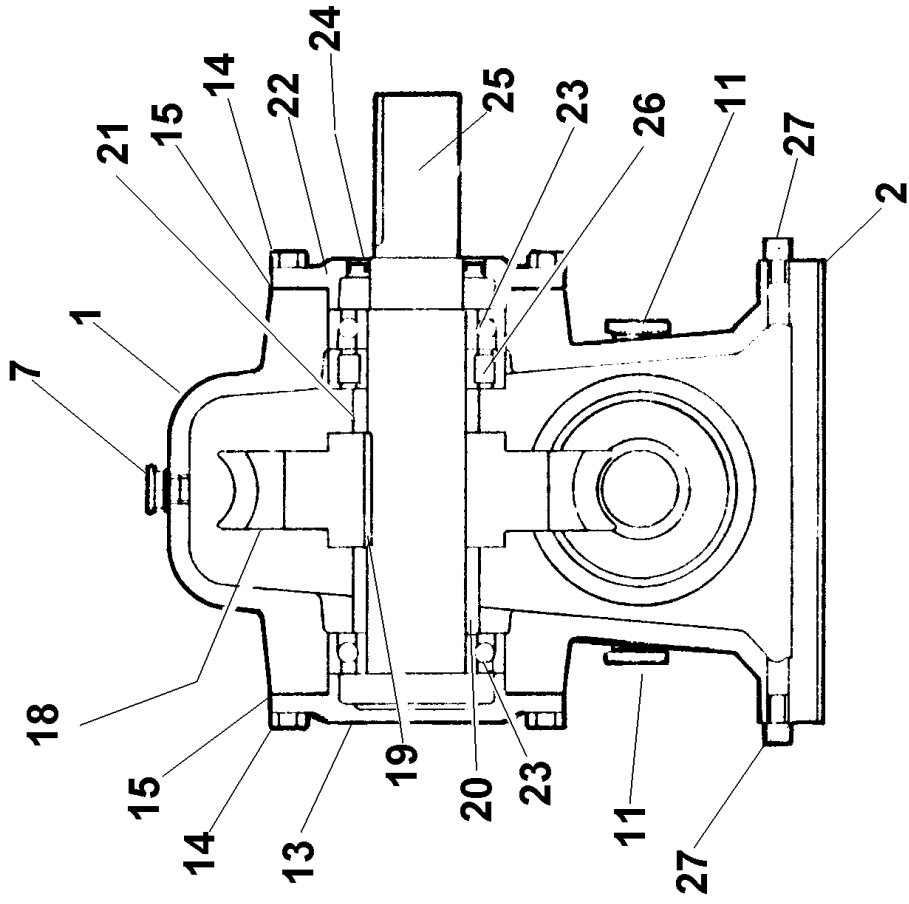
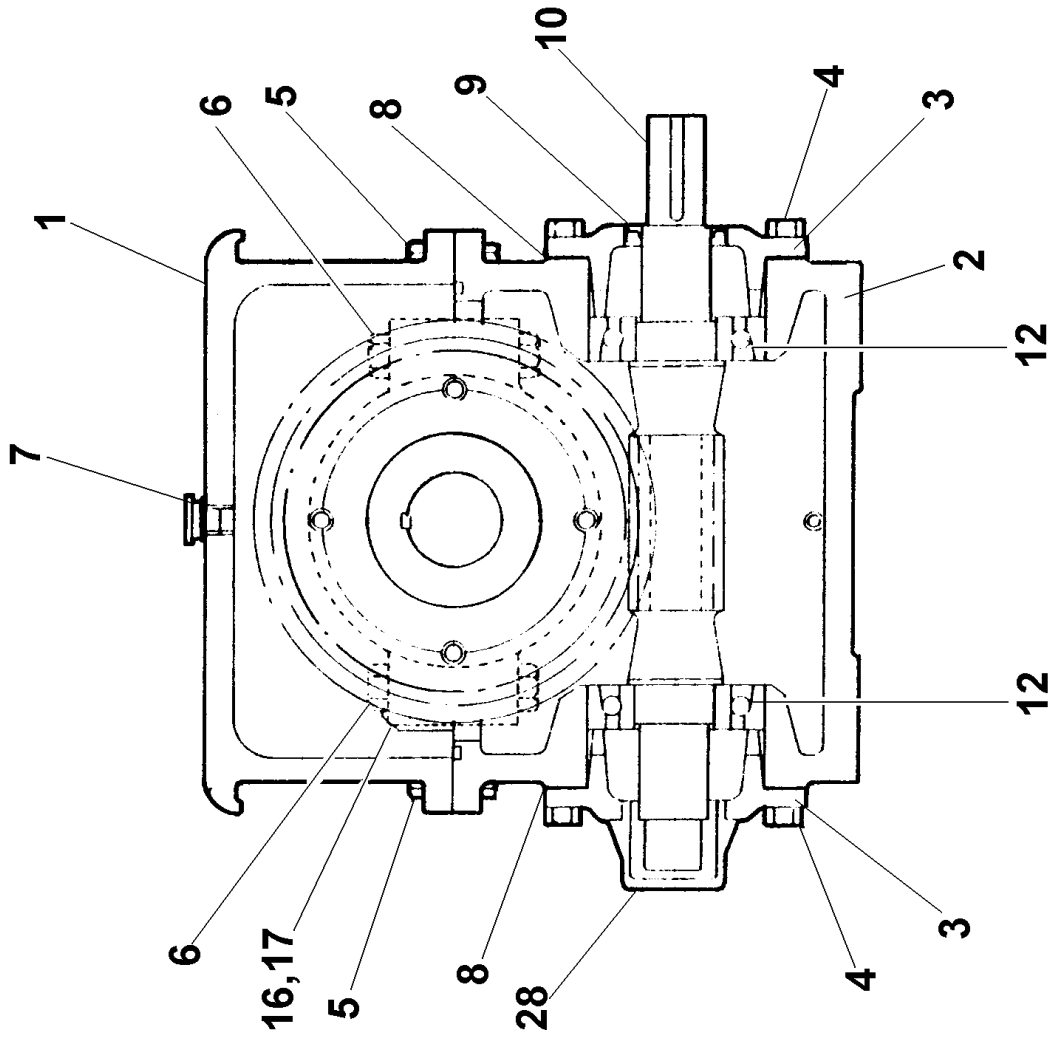

# RP400 WORM REDUCTION GEARBOX (RENOLD WU5)

*	CR679000	Gearbox Complete (Renold WU5)	1
1	CR679001	Gear Case	1
2	CR679002	Worm Shaft End Cover	2
3	CR679003	Worm Shaft End Cover Screw	12
4	CR679004	Joint Flange Bolts	4
5	CR679005	Joint Boss Bolts	4
6	CR679006	Filler Plug and Washer	1
7	CR679007	Worm Shaft Shims	as reqd.
8	CR679008	Worm Shaft Oil Seals	1
9	CR679009	Worm Shaft	1
10	CR679010	Oil Level Plug and Washer	2
11	CR679011	Worm Shaft Bearing	2
12	CR679012	Wheel Shaft Blank End Cover	1
13	CR679013	End Cover Screws	12
14	CR679014	Wheel Shaft Shims	as reqd.
15	CR679015	Oil Collector Boxes	2
16	CR679016	Oil Collector Box Screws	4
17	CR679017	Worm Wheel	1
18	CR679018	Wheel Shaft Key	1
19	CR679019	Wheel Shaft Distance Piece	2
20	CR679020	Wheel Shaft End Cover	1
21	CR679021	Wheel Shaft Bearing	2
22	CR679022	Wheel Shaft Oil Seal	1
23	CR679023	Wheel Shaft	1
24	CR679024	Oil Drain Plugs	2
25	CR679025	Fan	1
26	CR679026	Fan Guard	1
27	CR679027	Oil Seal Fan End	1

Identify gearbox Make & Model before ordering parts

# RP400 MAGNETIC BRAKE DRUM

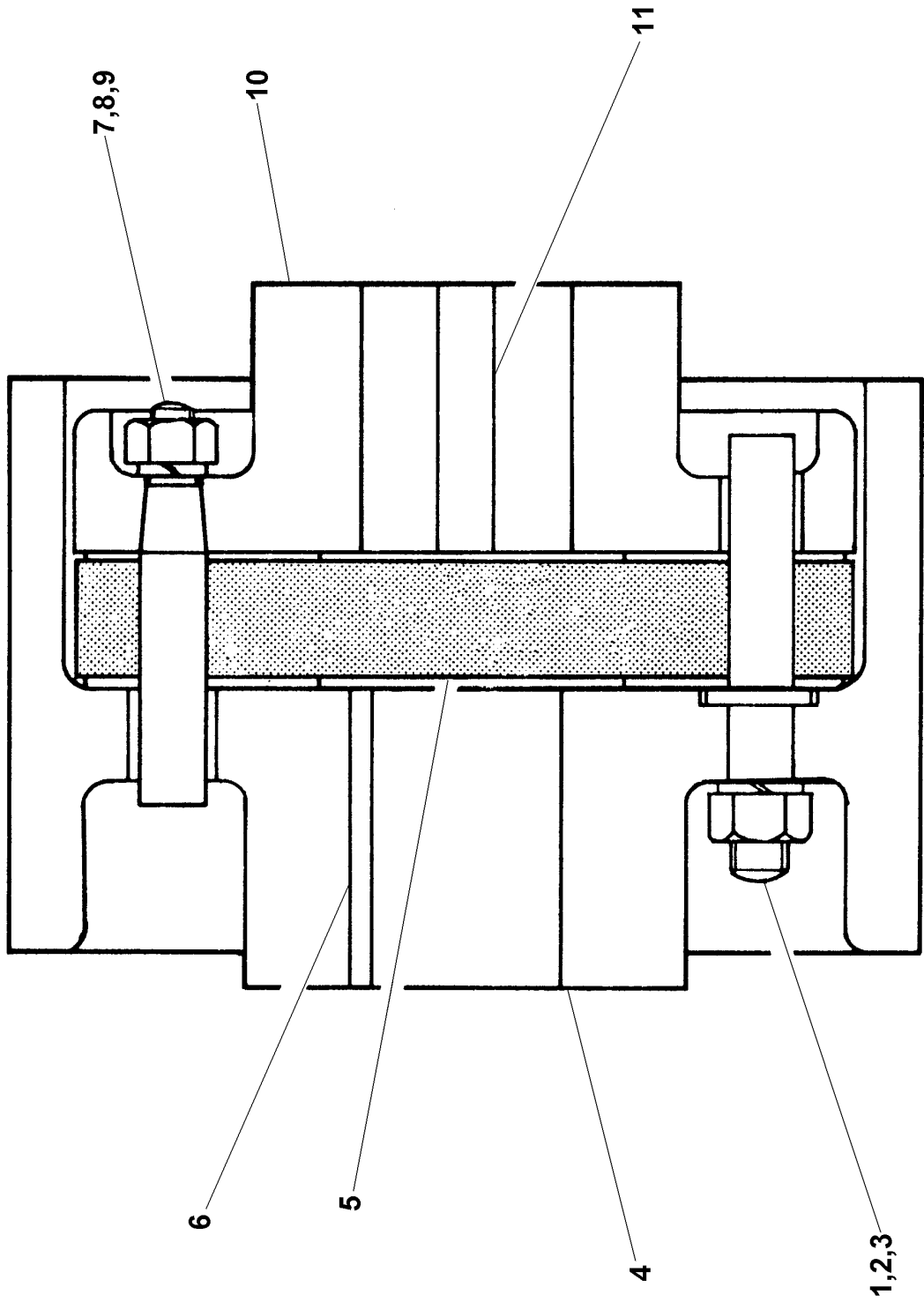

# RP400 MAGNETIC BRAKE DRUM

1	CR520154	Magnetic Brake Drum Pins	3
2	41S05	Spring Washer 3/8"	3
3	2S04	Nut 3/8" B.S.F.	3
4	CR210188	Magnetic Brake Drum	1
5	CR230010	Magnetic Brake Flexible Disc	1
6	CR320058	Key Gib Head 10 X 8 X 60mm	1
7	CR230011	Magnetic Brake Coupling Pin	3
8	41S04	Spring Washer 5/16"	3
9	2S03	Nut 5/16" B.S.F	3
10	CR230112	Magnetic Brake Coupling	1
11	CR320011	Key Gib Head 3/8"	1

# RP400 HYDRAULIC BATCHWEIGHER

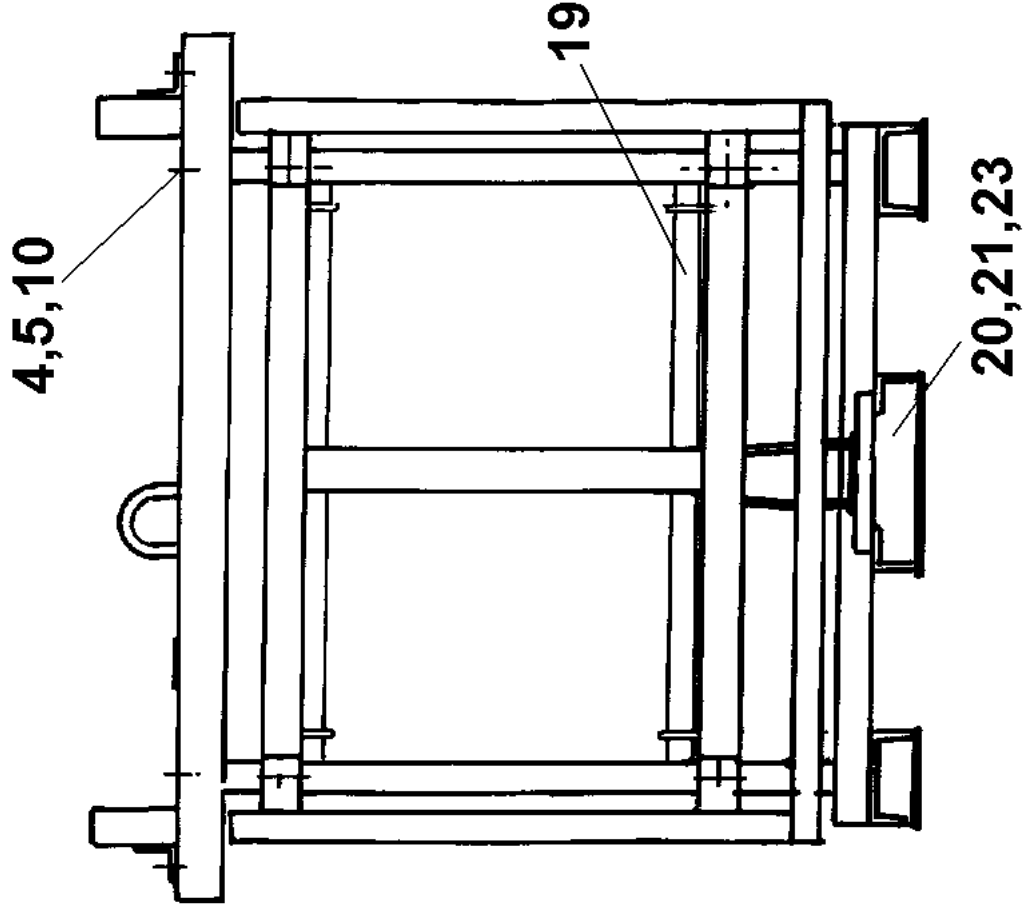
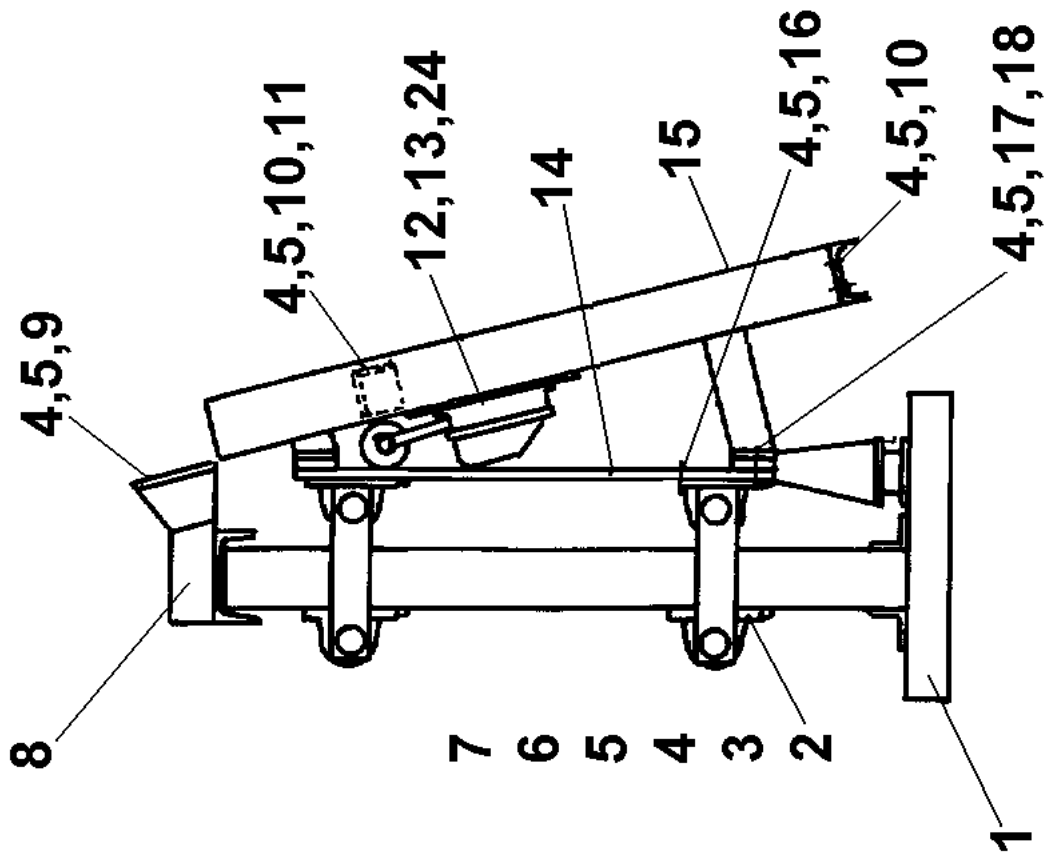

# RP400 HYDRAULIC WEIGHBATCHER ASSEMBLY

1	CR091039	Weighbatcher Support Frame Assembly	1
2	CR150921	Bearing Plummer Block, 1.25" Bore	8
3	8S05G	Bolt M12 x 55	8
4	7S05	Nut M12	50
5	17S06	Washer Spring M12	50
6	105S05	Washer Tapered M12	8
7	CR091039F	Bearing Plate & Stop, Welded to item 1	4
8	CR261504	Runway Supports LH & RH	1PR
9	52S05F	Bolt Csk Hd M12 x 30	4
10	8S05B	Bolt M12 x 30	22
11	CR091040J	Hopper Stops LH & RH, Welded to item 15	1PR
12	CR220005	Limit Switch, Obsolete use item 12 Below	
12	CR229083	Limit Switch, CA12-G	1
13	CR532203	Support Plate Limit Switch	1
14	CR261508	Weighbridge, RP400 Standard 4' 2.25" Long	1
15	CR091040	Runway Assembly c/w item 11	1
16	8S05F	Bolt M12 x 50	4
17	8S05M	Bolt M12 x 80	4
18	8S05J	Bolt M12 x 65	4
19	CR261505	Parallel Shaft Units	2
20	CR179002	Hydraulic Loadcell & Gauge Assembly 0-1000Kg Range	1
21	CR179003	Mountings, Anti Side Load	



# RP400 BATCHWEIGHER ASSEMBLY

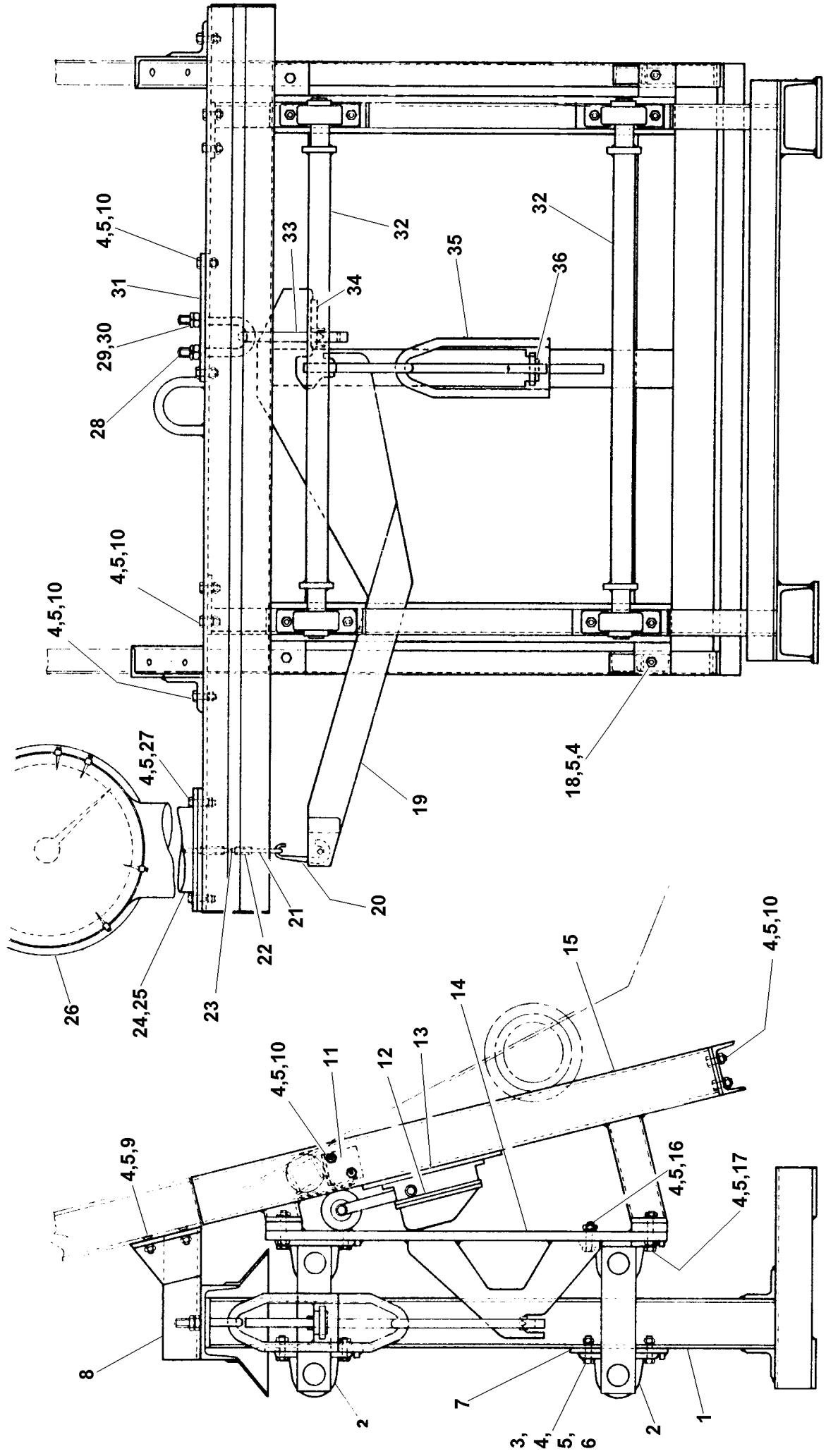

# RP400 BATCHWEIGHER

1	CR091039	Weigbatcher Support Frame Assembly	1
2	CR150921	Plummer Blocks	8
3	8S05G	Bolt M12 x 55	8
4	7S05	Nut M12	50
5	17S06	Spring Washer M12	50
6	105S05	Tapered Washer M12	8
7	CR091039F	Bearing Plate and Stop	4
8	CR261504	Runway Supports LH & RH	2
9	52S	M12 x 30 Csk Hd Bolt	4
10	11S05	M12 x 30 Hex hd Bolt	22
11	CR091040J	Hopper Stops (LH) Hopper Stops (RH)	1 1
12	CR220005	Limit Switch (Obsolete use item 12 below)	
12	CR229083	Limit Switch (replaces above)	1
13	CR532203	Weighbatcher Limit Switch Support Plate	1
14	CR261508	Bridge	1
15	CR091040	Runway Assembly	1
16	8S05F	Bolt M12 x 50	4
17	8S05M	Bolt M12 x 80	4
18	8S05J	Bolt M12 x 65	4
19	CR170079	Balance Arm	1
20	CR170075	Knife Edge Hook ('C' Link)	1
21	CR170078	Dial Pull Hook	1
22	CR170076	Dial Pull Link Adjuster	2
23	CR530543	Connecting Rod	1
24	CR260598	Weigh Dial Pedestal	1
25	183S05H	Screw Set Skt Csk 1/2" U.N.F. x 1 1/2"	4
26	CR170128	Weigher Dial Head & Pedestal Comp.	1
27	8S05C	M12 x 35 Hex Hd Bolt	4
28	CR170008	U' Bolt	1
29	253S06	Nut 5/8" BSW	2
30	79S07	Nut Thin 5/8" BSW	2
31	CR532206	U' Bolt Support Plate	1
32	CR261505	Paralle Shaft Units	2
33	CR170014	Supporting Link	1
34	CR170080	Adjustable Knife Edge	1
35	CR170010	Supporting Link Coupled	1
36	CR170018	Knife Edge Abutment	3

# RP400 BATCH WEIGHER DIAL ASSEMBLY

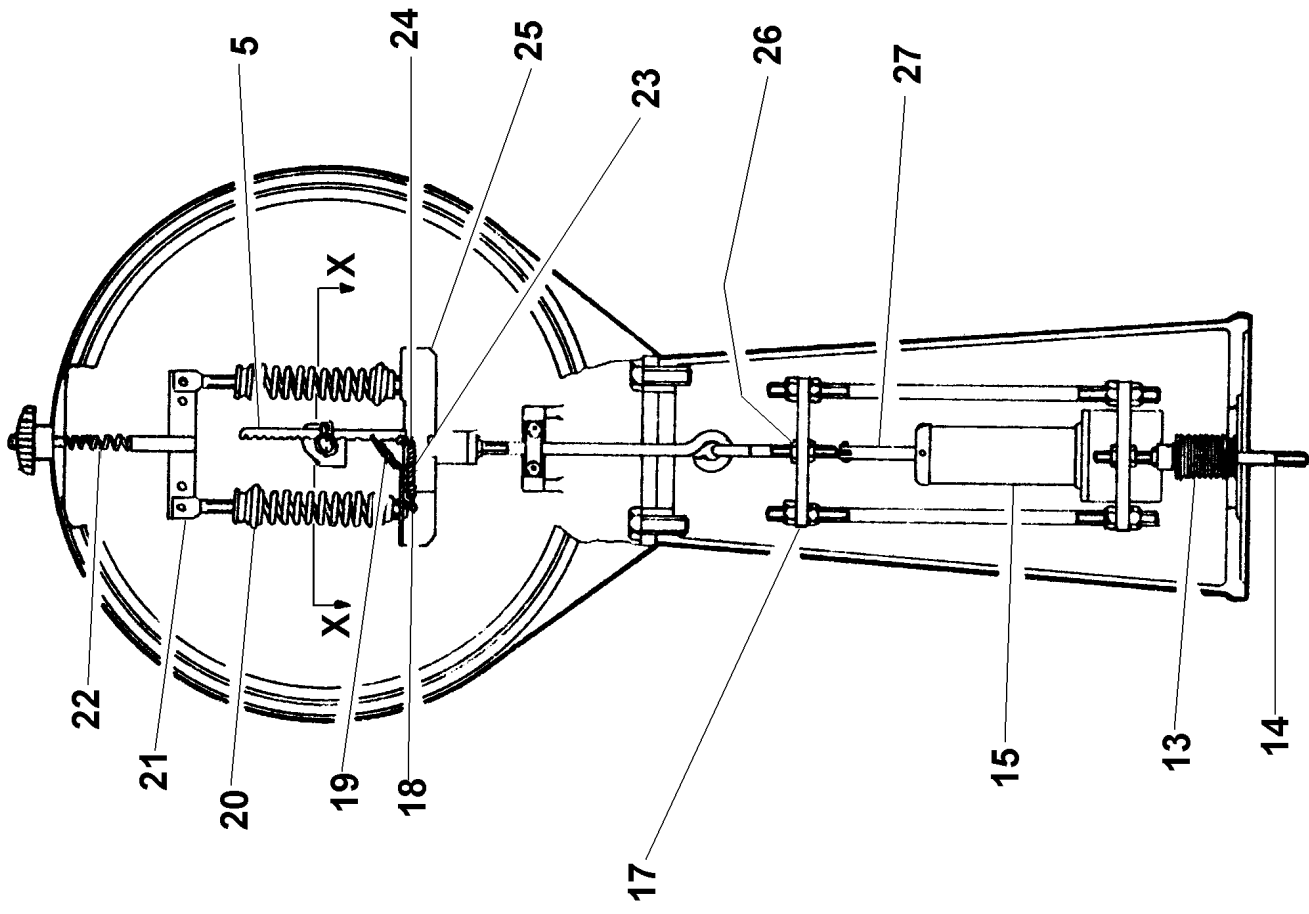
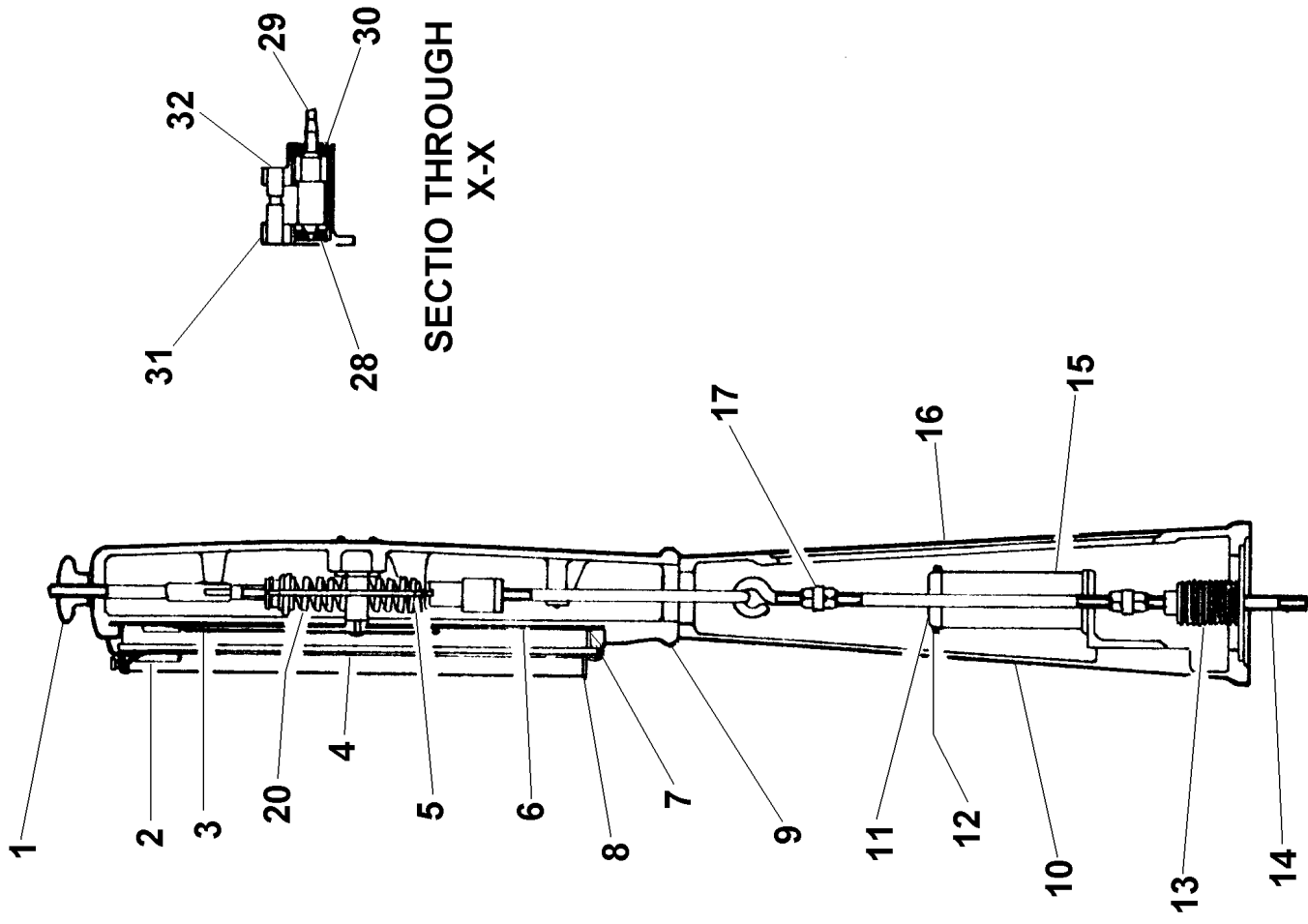

# RP400 BATCHWEIGHER DIAL

*	CR170128	Weigh Dial & Pedestal Assembly RP400	
*	CR170129	Weigh Dial & Pedestal Assembly RP550-RP850	
*	CR170130	Weigh Dial & Pedestal Assembly RP1250-RP1500	
1	CR170087	Tare Adjuster	1
2	CR170088	Indicator	4
3	CR170089	Finger Assembly	1
4	CR170090	Glass	1
5	CR170091	Rack	1
6	CR170120	Dial (2,200lbs RP400)	1
*	CR170121	Dial (1,100lbs RP200)	1
*	CR170092	Dial (3,300lbs RP550-RP850)	1
*	CR170124	Dial (4,400lbsRP1250-RP1500)	1
7	CR170093	Bezel	1
8	CR170094	Indicaotr Rim Assembly	1
9	CR170095	Dial Head	1
10	CR170096	Dial Pedestal	1
11	CR170097	Dashpot Cylinder Cap	1
12	CR170098	Dashpot Cylinder Cap Screw	7
13	CR170099	Corrugator	1
14	CR170100	Connecting Rod	1
15	CR170101	Dashpot Cylinder	1
16	CR170102	Pedestal Door	1
17	CR170103	Dashpot Cylinder Assembly	1
18	CR170104	Spring Rivet	1
19	CR170105	Rack Spring	1
20	CR170106	Main Speing Assembly	1
21	CR170107	Hanger Bar Assembly	1
22	CR170108	Adjuster Compression Spring	1
23	CR170109	Tension Spring	1
24	CR170110	Tension Spring Rivet	1
25	CR170111	Shock Absorber Mechanism Assembly	1
26	CR170112	Cross-Bar Nut	2
27	CR170113	Dashpot Plunger Rod Assembly	1
28	CR170114	Pearing Bush	1
29	CR170115	Pinion	1
30	CR170116	Bearing Bush	1
31	CR170117	Pinion Housing Assembly	1
32	CR170118	Guide Rack Pillar	1

\* Not illustrated

# RP400 DRAGLINE SHOVEL DRIVE, PULLEYS & JIBS

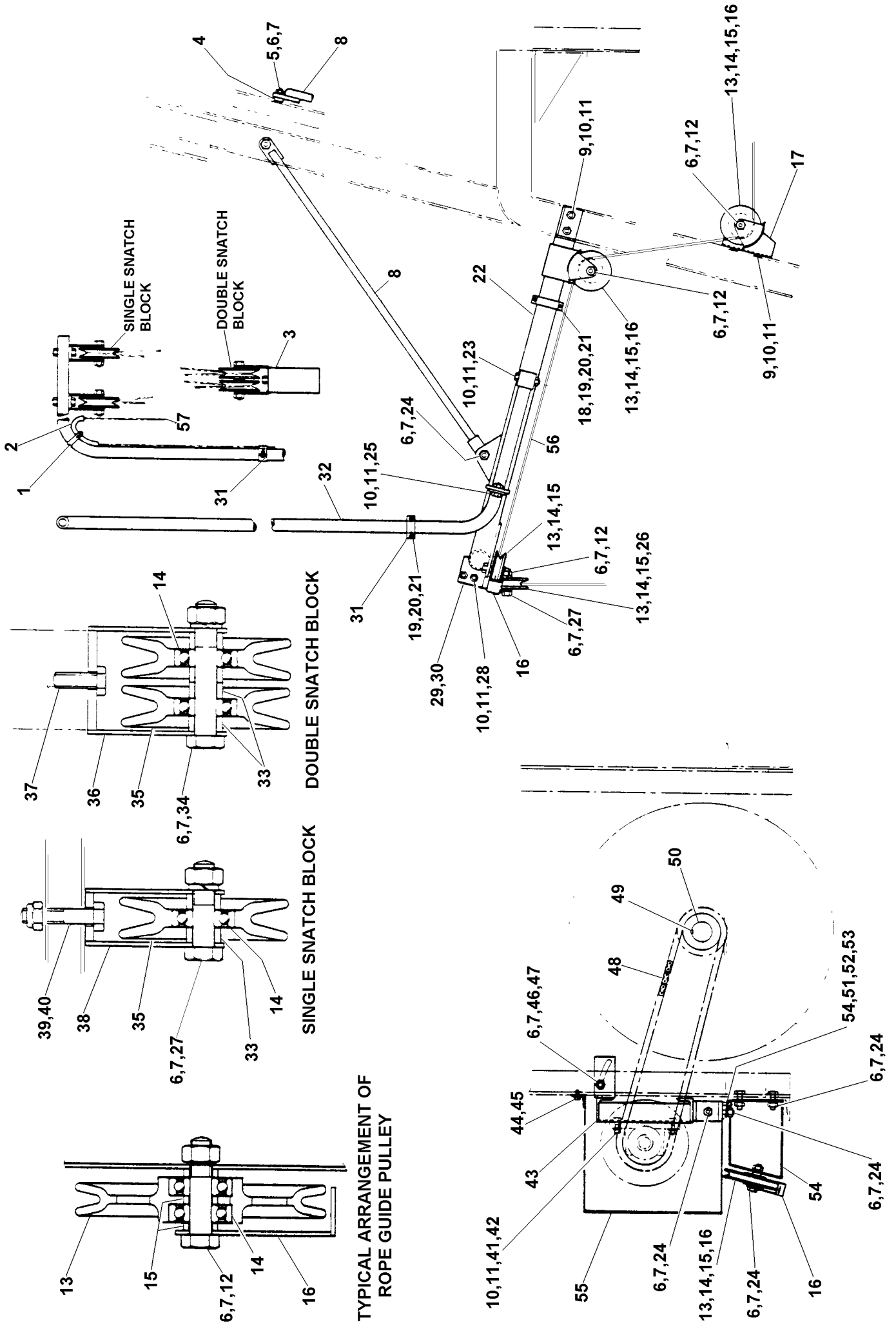

# RP400 SCRAPER SHOVEL DRIVE, PULLEYS & JIBS

1	97S11	Hose Clip	1
2	CR510323	Electric Cable Hose	1
3	CR210017	Snatch Block Weight	1
4	CR630350	Packing	2
5	52S06K	Screw Set Csk Skt M16 x 50	2
6	7S06	Nut M16	20
7	17S08	Spring Washer M16	20
8	CR241517	Jib Boom Tie Rod	2
9	52S05F	Screw Set Csk Skt M12 x 30	6
10	7S05	Nut M12	16
11	17S06	Spring Washer M12	16
12	8S06M	Bolt M16 x 80	4
13	CR340515	Cast Iron Pulley	5
14	CR150846	MJ17 SRR Bal Bearing	14
15	CR630352	Pulley Distance Piece	13
16	CR540082	Pulley Shroud	4
17	CR261518	Pulley Support Bracket	1
18	CR540078	Electric Cable Clip	1
19	11S02A	Screw Set M6 x 16	4
20	7S02	Nut M6	4
21	17S03	Spring Washer M6	4
22	CR261519	Jib Boom Tie Rod	1
23	8S05J	Bolt M12 x 65	1
24	8S06D	Bolt M16 x 40	8
25	11S05D	Screw Set M12 x 30	1
26	267S09	Washer Flat M16	2
27	8S06J	Bolt M16 x 65	3
28	8S05D	Bolt M12 x 40	4
29	CR530080	Jib Block Support Plate	2
30	CR260075	Jib Block	1
31	CR540077	Electric Cable Piece	1
32	CR261520	Electric Cable Mast	1
33	CR630351	Pulley Distance Piece	8
34	8S06P	Bolt M16 x 100	1
35	CR340025	Aluminium Allow Pulley	4
36	CR260070	Double Pulley Snatch Block Bracket	1
37	79S05C	Screw Set 1/2" BSW x 1 1/4"	1
38	CR260069	Single Pulley Snatch Block Bracket	2
39	8S05G	Bolt M12 x 55	2
40	59S04	Nyloc Nut M12	2
41	8S05E	Bolt M12 x 45	4
42	267S07	Washer Flat M12	4
43	CR241507	Scraper Shovel Winch Frame	1
44	11S04B	Screw Set M10 x 20	2
45	17S05	Spring Washer M10	6
46	8S06E	Screw Set M16 X 45	2
47	105S07	Tapered Washer M16	2
48	CR200114	3/4" Pitch Simple Chain	1
49	CR320088	Key Gib Head 18mm x 60	1
50	CR200150	Simple Chain Wheel	1
51	11S04D	Screw Set M10 x 30	2
52	105S05	Tapered Washer M10	2
53	7S04	Nut M10	2

# RP400 SCRAPER SHOVEL DRIVE, PULLEYS & JIBS

54	CR261512	Pulley Support Bracket	1
55	CR542026	Winch Guard	1
56	CR350002	Wire Rope	1
57	CR220013	Electric Cable (25 metres long)	1

# RP400 DRAGLINE SHOVEL WINCH UNIT ASSEMBLY

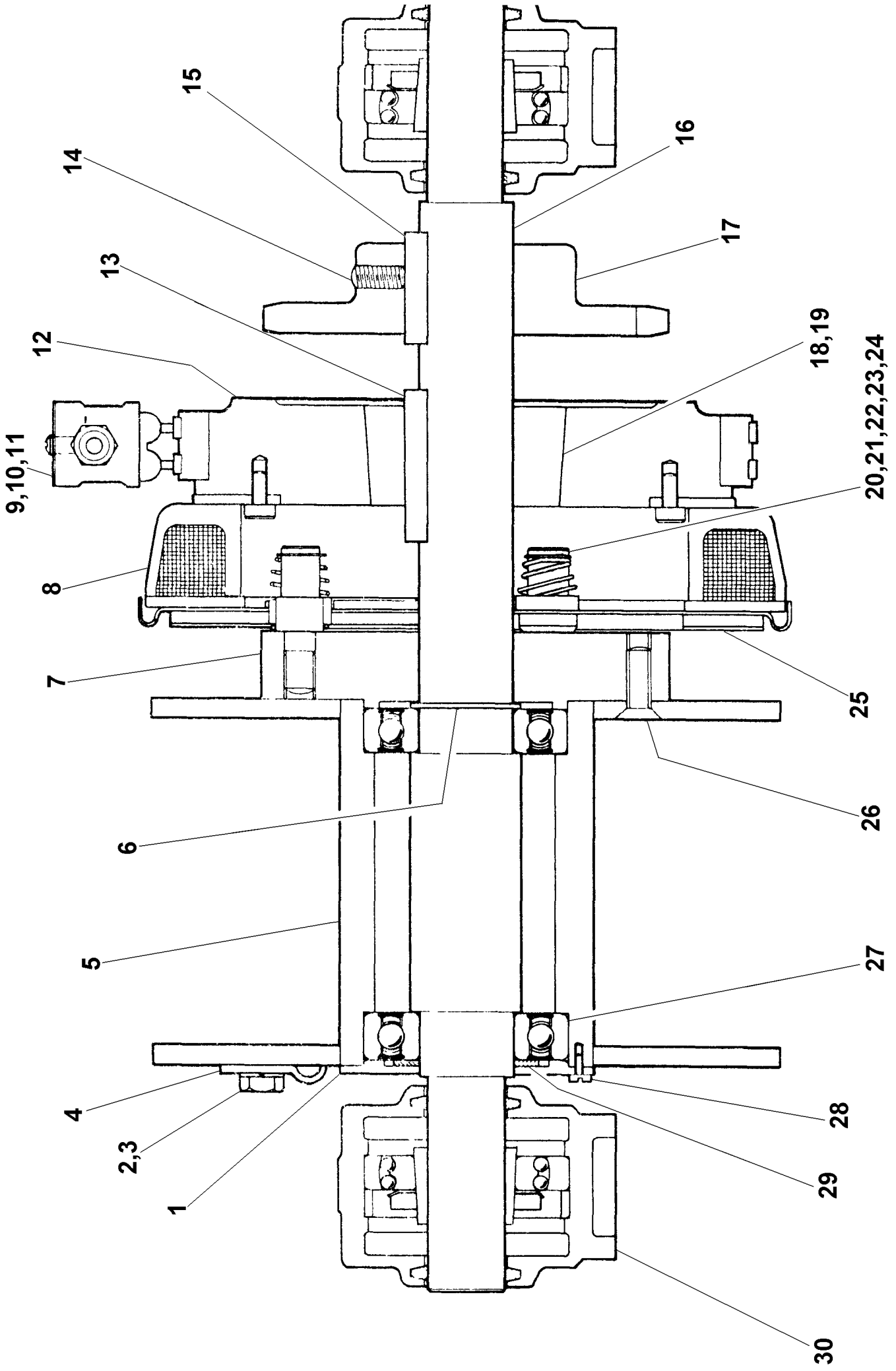



# RP400 SCRAPER SHOVEL WINCH UNIT

1	CR531053	Bearing Retainer Plate	1
2	79S03U	Screw Set 3/8" x 1/2" B.S.F.	1
3	41S05	3/8" Spring Washer	1
4	CR540080	Wire Rope Securing Clip	1
5	CR531051	Winch Rope Drum	1
6	CR243067	Circlip	1
7	CR531052	Clutch Mounting Plate	1
8	CR680016	Clutch Magnet (W114/825 8.9/16" Dia)	1
8	CR609016	Clutch Magnet (825 WR8B3P2 6 Volt)	1
9	CR680027	Brush Holder Case	1
10	CR680028	Brush Box and Rivets	1
11	CR680029	Carbon Brush (A515)	4
12	CR680017	Clutch Rotor (825 W112/825 WR8B9P1)	1
12	CR689017	Clutch Rotor (WR8B9P1 Slip Ring c/w 5301-749-001 )	1
13	CR320071	Clutch Rotor Key	1
14	57S06G1	Screw Grub M10 x 16	1
15	CR320090	Key	1
16	CR520533	Winch Shaft	1
17	CR200149	Chain Pinion	1
18	CR680021	Taper Lock Bush 40MM Dia 1.5" Bore	1
19	CR680020	Taper Lock Grub Screw	3
20	CR680022	Clutch Drive Pin W22	3
21	CR680023	Clutch Drive Spring (Follw Up) W23	3
22	CR680024	Retainer Ring W24	3
23	CR680025	Spring Seat W25	3
24	CR680026	Clutch Spring (Release) W26	3
**	CR689022	Clutch Kit (See note below)	
25	CR680015	Clutch Armature Plate (825 Clutch 8.9/16" Dia)	1
25	CR689015	Clutch Armature Plate (5301-111-018-SQ))	1
26	5S04A	Bolt Csk Skt 3/8"x1 1/2"	6
27	CR150819	Ball Bearing	2
28	82S03C	Screw Set Rnd HD 2BA x 1/2"	4
29	CR680094	Felt Seal	1
30	CR151097	Plummer Block	2
*	CR319045	Complete Clutch Assembly (8.9/16" Diameter)	1
*	CR319046	Complete Clutch Assembly (10" Diameter)	1

\* Not illustrated

\*\* Kit consists of items:- 20, 21, 22, 23, 24

# RP400 DRAGLINE SHOVEL OVER RUN BRAKE

" "

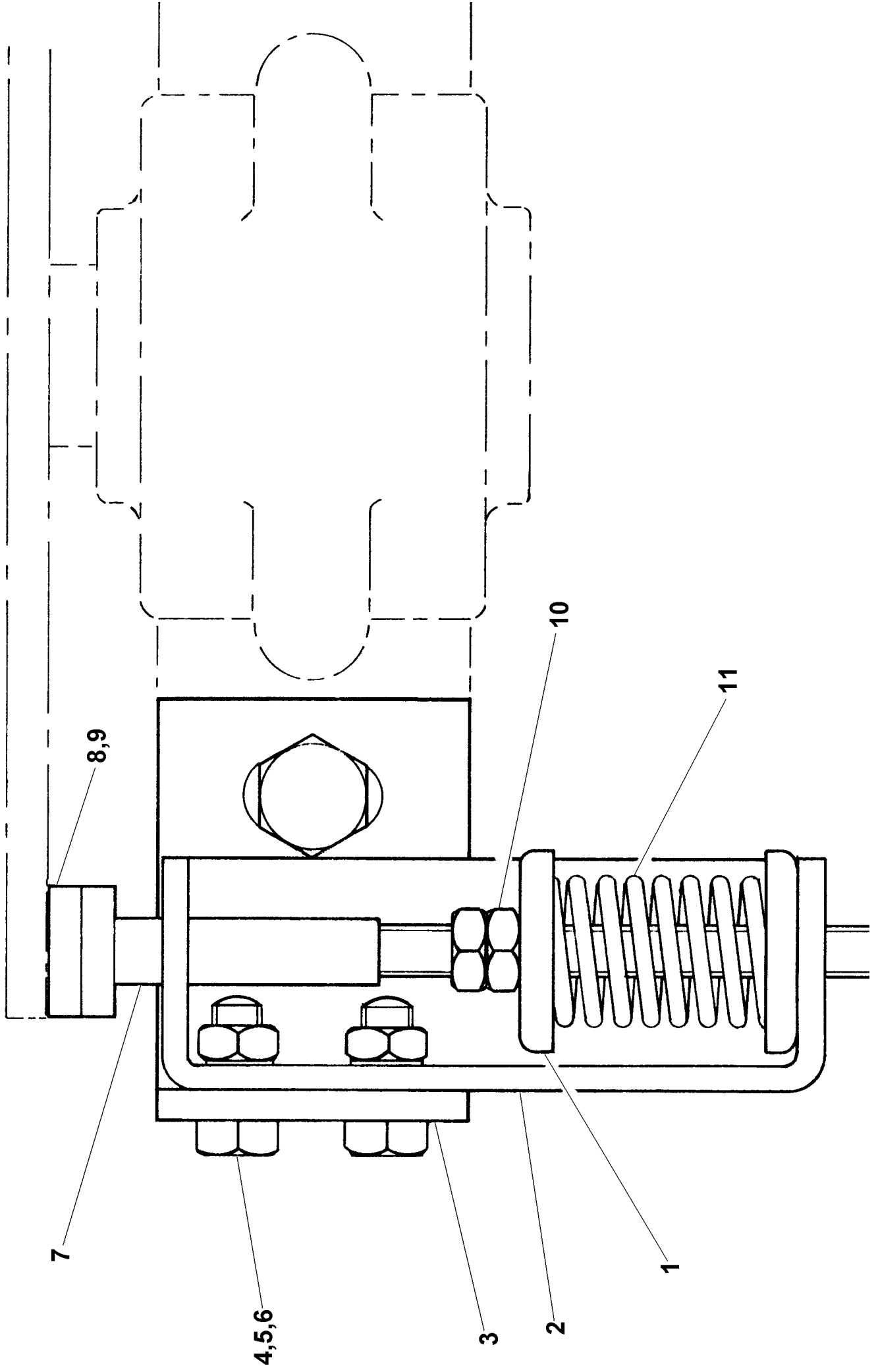

# RP400 SCRAPER SHOVEL WINCH OVER RUN BRAKE

1	CR500004	Spring retaining Washer	2
2	CR541156	Brake Bracket	1
3	CR531108	Brake Unit Support Angle	1
4	11S04C	Screw Set M10 x 25	2
5	7S04	Nut M10	2
6	17S05	Spring Washer M10	2
7	CR520012	Brake Spindle and End Plate Complete	1
8	CR250012	Ferodo Brake pad	1
9	CR243068	Copper Rivet	2
10	78S03	3/8" BSW Check Nuts	2
11	CR330014	Spring	1

# RP400 DRAGLINE SHOVEL ASSEMBLY

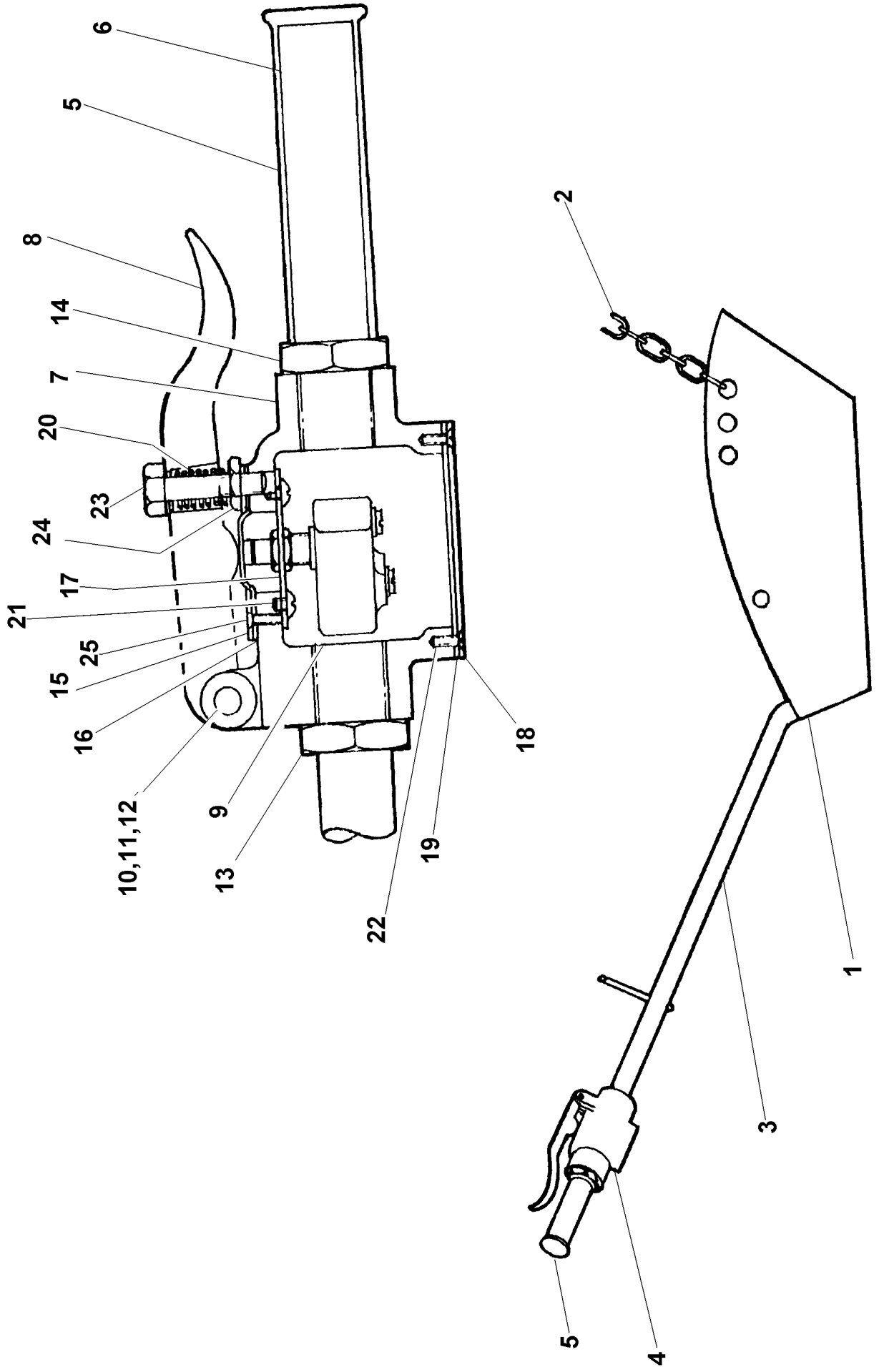

# RP400 SHOVEL, HANDLES & SWITCH

1	CR420002	Shovel Blade	1
2	CR600002	Chain & Ring (13 Links 1'. 8.5/16" long)	1
3	CR420001	Shovel Handles	1
4	CR080422	Switch, consists of items 6-25 below	1

**Although some individual items are still available, the Switch Assembly as illustrated is obsolete and is replaced by Item 29 below.**

5	CR570004	Rubber Handgrip 1" Bore	2
6	CR530083	Switch Handle	1
7	CR210019	Push Button Case (7053)	1
8	CR210018	Switch Trigger (7052)	1
9	CR220313	Push Button Switch	1
10	CR520048	Fulcrum Pin	1
11	10S03	Washer Flat 3/8"	2
12	44S03C	Split Pin 1/8" x 1"	2
13	194S07	Check Nut 3/4" B.S.P.	1
14	74S09	Check Nut 1" B.S.F.	1
15	CR570024	Rubber Cover	1
16	CR490049	Washer Special	1
17	CR541299	Fixing Plate	1
18	CR530082	Cover Plate	1
19	CR560020	Gasket	1
20	CR330018	Spring	1
21	CR241097	Retaining Screw 3/16" x 1/2" B.S.W.	2
22	CR241070	Cover Plate Screw Csk 3/16" x 1/2"	4
23	79S02D	Bolt 5/8" x 1.1/2" B.S.W.	1
24	78S02	Check Nut 5/16" B.S.W.	1
25	CR241070	Top Cover Screw Csk 3/16" x 1/2" B.S.W.	9
*26	11S05F	Screw Set M12 x 40 (Chain Retaining)	2
*27	59S04	Nut Nyloc M12 (Chain Retaining)	2
*28	267S07	Washer Flat M12 (Chain Retaining)	2

\* Not Illustrated

29	CR080422	Kit, Dragline Switch Replacement, consists of following items	1
29A	208561000	Switch	1
29B	208143000	Sleeve, 70mm Long	1
29C	250166010	Fitting Cable Gland	1
29D	463504000	Washer Rubber Cable Gromet	1
29E	555214800	Plate Clamp	1
29F	8S01J	Bolt M5 x 65	2
29G	267S03	Washer Flat M5	4
29H	59S13	Nut Nyloc M5	2

## RP400 N.R. RANGE ELECTROMAGNETIC BRAKE

SEPARATE BRAKE UNITS ONLY

THE BRAKE FITTED WAS FITTED TO  
MACHINES BUILT 1973 ONWARDS.

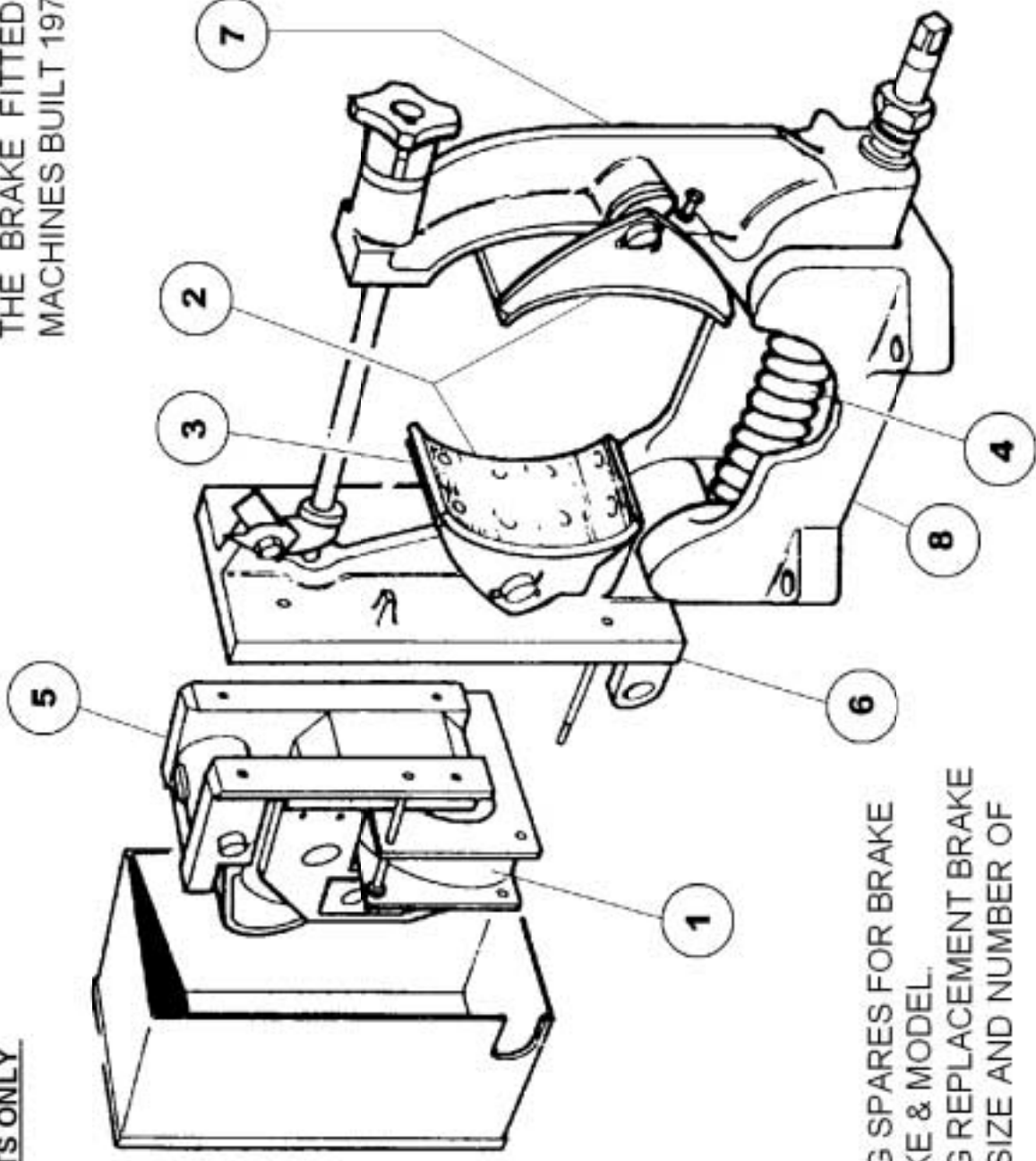

WHEN ORDERING SPARES FOR BRAKE  
UNIT QUOTE MAKE & MODEL.  
WHEN ORDERING REPLACEMENT BRAKE  
SHOES QUOTE SIZE AND NUMBER OF  
RIVET HOLES.

# RP400 NR RANGE ELECTROMAGNETIC BRAKE UNIT

## SEPARATE BRAKE UNITS ONLY

	CR550115	Brake unit complete	1
1	CR550116	Electric Coil	1
2	CR550117	Brake Linings & Rivets	1 SET
3	CR550118	Brake Shoes	2
4	CR550119	Torque Spring	1
5	CR550120	Magnet Unit (Less Coil)	1
6	CR550121	Magnet Carrier Arm (Less Shoe)	1
7	CR551022	Plain Arm (Less Shoe)	1
8	CR550123	Base	1

It is not possible to supply other major parts as separate items. If any other items are required it will be necessary to replace the complete brake assembly. This is due to the number of brake units fitted over the years from different manufacturers and the difficulties encountered identifying the different types. When ordering spares please quote the voltage, make, model and if possible the serial number together with a full description of the part required. When ordering replacement brake linings please give the physical dimensions together with the number of rivet holes required.

# RP400 A.C. SOLENOID BRAKE

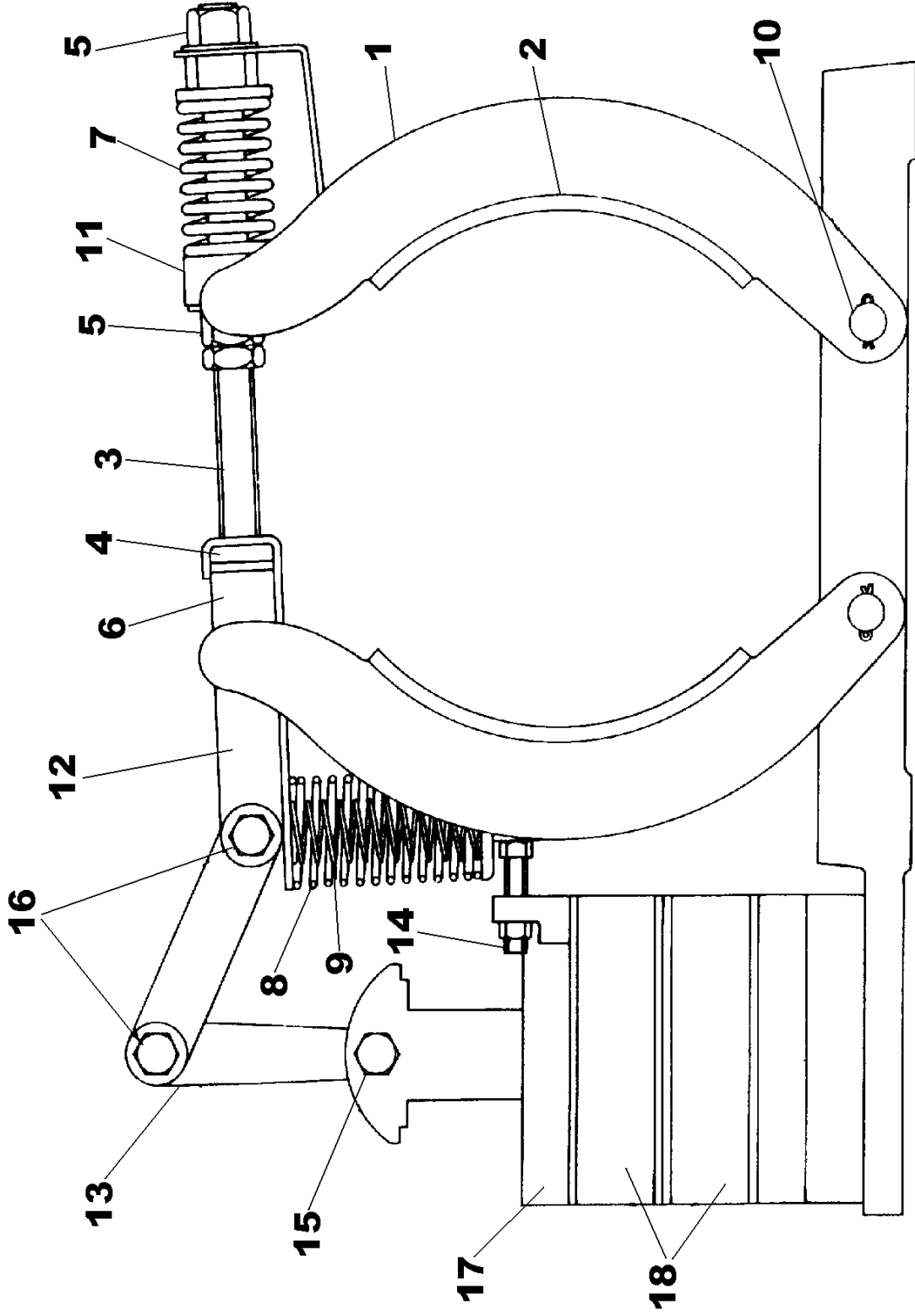

WHEN ORDERING SPARES FOR BRAKE QUOTE VOLTAGE, MAKE , MODEL AND SIZE. WHEN ORDERING REPLACEMENT BRAKE SHOES QUOTE PHYSICAL DIMENSIONS



## RP400 A. C. SOLENOID BRAKE

1	CR550042	Shoes (Complete With Linings)
2	CR550043	Brake Linings & Rivets
3	CR550044	Adjusting Screw
4	CR550045	Spring Gland
5	CR550046	Adjusting Screw Nut
6	CR550047	Adjusting Nut
7	CR550048	Load Spring
8	CR550049	Solenoid Spring Large
9	CR550050	Solenoid Spring Small
10	CR550051	Shoe Lever Hinge Pins
11	CR550052	Load Spring Block
12	CR550053	Operating Levers
13	CR550054	Plunger Link
14	CR550055	Equalising Screw & Nut
15	CR550056	Plunger Hinge Bolt & Nut
16	CR550057	Lever Hinge, Bolt, Nut & Collar
17	CR550058	Solenoid
18	CR550059	Solenoid Coils (both coils should be replaced together)

When ordering spares for the brake unit please quote voltage, make, model and serial number.  
When ordering brake shoes please quote physical dimensions

# RP400 ELECTROMAGNETIC BRAKE

SEPARATE BRAKE UNITS ONLY

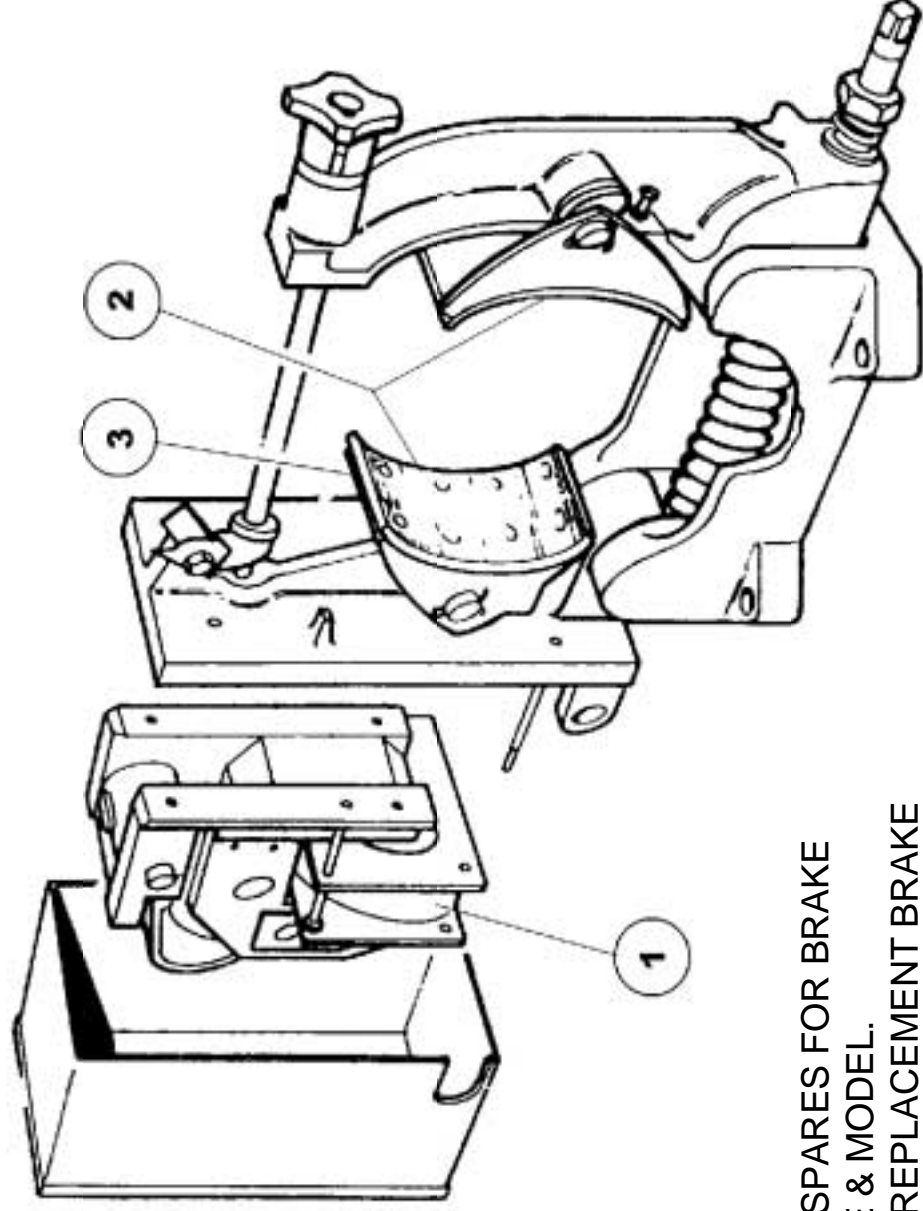

WHEN ORDERING SPARES FOR BRAKE  
UNIT QUOTE MAKE & MODEL.  
WHEN ORDERING REPLACEMENT BRAKE  
SHOES QUOTE SIZE AND NUMBER OF  
RIVET HOLES.

# RP400 ELECTROMAGNETIC BRAKE UNIT

## SEPARATE BRAKE UNITS ONLY

	CR550114	Brake Unit Complete Dewhurst 6" Diameter	1
1	CR22074	Electric Coil	1
2	CR551423	Brake Linings & Rivets	1 SET
3	CR551424	Brake Shoes Retaining Screws	12

It is not possible to supply other major parts as separate items. If any other items are required it will be necessary to replace the complete brake assembly. This is due to the number of brake units fitted over the years from different manufacturers and the difficulties encountered identifying the different types. When ordering spares please quote the voltage, make, model and if possible the serial number together with a full description of the part required. When ordering replacement brake linings please give the physical dimensions together with the number of rivet holes required.

## **CROKER LOADER**

### **WIRE ROPE RENEWAL PROCEDURE**

1. Place Loader Bin on hopper stops. Loosen nut from rope anchor bolt, item 1, on one rope drum only, item 2.
2. Remove end of old wire rope from anchor bolt.
3. Fit end of new wire rope to anchor bolt and tighten nut.
4. Lay other end of new wire rope end to end with old wire rope removed in part 2. Bind both ends together with sticky tape (electrical or masking tape).
5. Carefully pull on the old wire rope to pull the new wire down to the bottom of the loader bin and around the rear axle rope pulley, item 3, and up through the front axle rope guide, item 4.
6. Remove front axle rope retainer blocks, items 5 and 6, and slide onto the new rope.
7. Continue to pull the wire and thread through the second rope guide, item 7, and down around the second rope pulley, item 8, and up to the second rope drum, item 9.
8. Remove old wire from second anchor bolt, item 10, on second rope drum, item 9, and remove tape from ends of old and new wire.
9. Fit second end of new wire to second anchor bolt, item 10, on second rope drum, item 9.
10. Tighten anchor bolt nuts on both rope drums.
11. The new wire should now run over the front edges of both rope drums and down to front edges of both the lower axle rope pulleys, items 3 and 8, and up the back of the rope pulleys to the rope guides, items 4 and 7, with both rope retainer blocks, items 5 and 6, located on the section of wire rope between the two rope guides at the back of the bin.
12. Start and stop the loader by hand, using the start and stop buttons, and take out all the slack of the wire rope in the raise direction (see important note on page 30), ensuring that the wire slots into both axle rope pulleys, item 2 and 9, and that the wire has wound evenly onto both rope drums.

Make sure the loader bin is level and sitting on weigher track stops before positioning rope retainer blocks, items 5 and 6, approximately 2 inches (50 mm) in board of rope guides, item 4 and 7, each side and make fast retainer blocks onto wire.

13. Check that both limit switches are working correctly.
14. Make sure loader bin clears both sides of rope drums at the top of its operation.

**NOTE:** Bin reaches end of travel between rope drums.

### **IMPORTANT NOTE**

Ensure that the slack wire is taken up in the raise direction and not the lowering direction. If the rope is wound incorrectly in the reverse direction on to the rope drums the hopper will not stop at the upper limit switch. It will continue until it makes contact with the top of the structure and will continue to heave until the wire rope breaks, with the result , if both sides of the wire fail at the same time, that the hopper will drop to the bottom end of the skip track.

# RP400 WIRE ROPE RENEWAL PROCEDURE

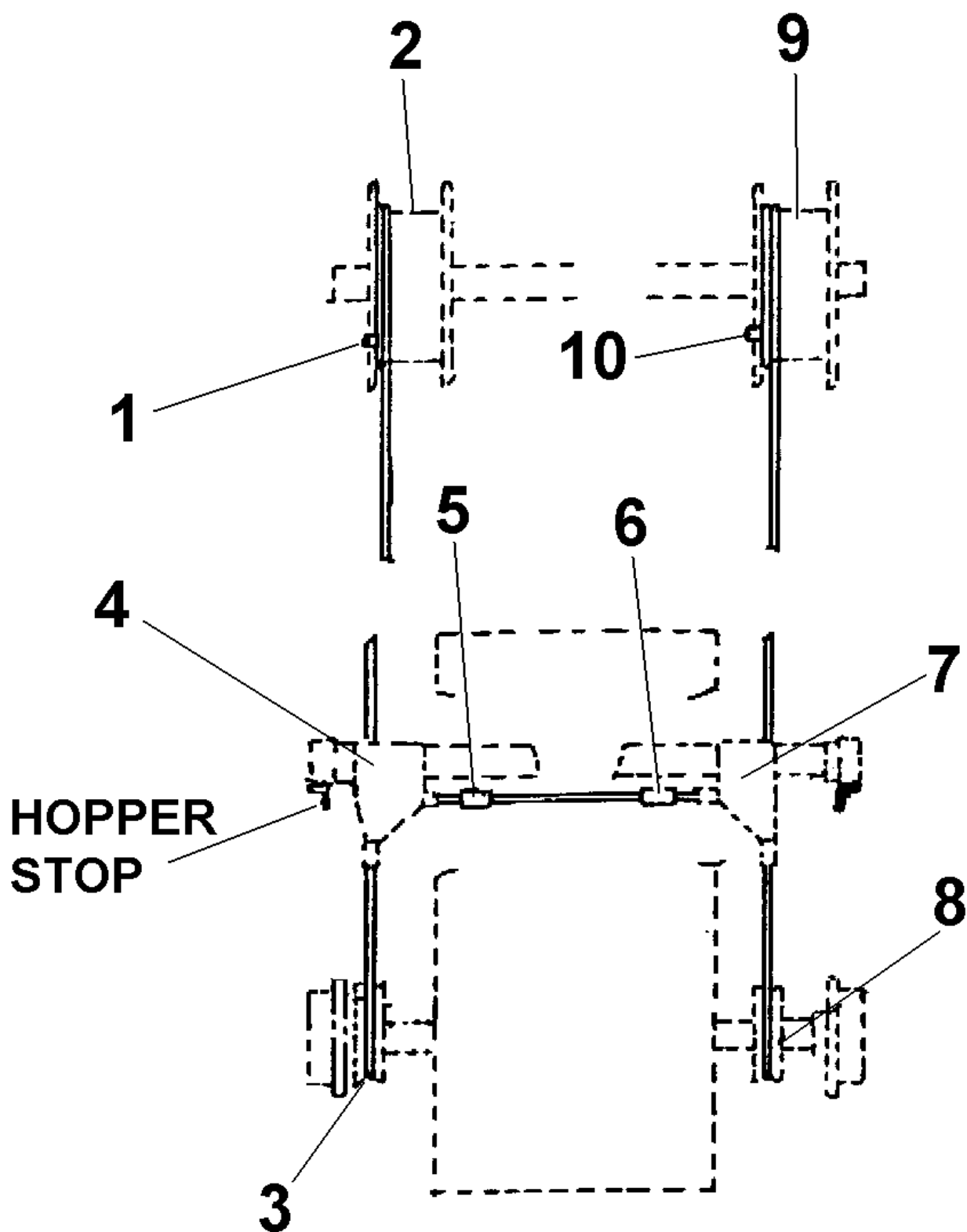

# **WIRE ROPES**

## **SAFETY NOTES**

### **ALWAYS**

Store and handle the wire rope correctly, wear protective gloves and eye protection.

Check the rope test certificate is still in date especially if the rope has been in storage also check that the certificate is applicable to the rope.

Remove the rope from any reel or coil correctly and without kinking.

Only use correct end terminations and rope anchors.

Ensure that the rope is correctly located and seated on the rope drum.

Ensure that the rope is correct for the application and only use good quality ropes from reputable suppliers.

Inspect the wire rope for damage, wear, corrosion or abuse at the start of each shift.

Keep the wire rope clean and maintained in accordance with the manufacturers instructions.

### **NEVER**

Try to shorten any wire rope by knotting.

Bend a wire rope over small radii.

Subject wire ropes to shock loadings.

Allow wire ropes to run over sharp edges or abrasive surfaces etc.

Subject wire ropes to extremes of temperature.

Use wire ropes with obvious signs of mechanical, corrosive or heat damage.

Use wire ropes that are worn, frayed, split or corroded.

## **STORAGE**

Store wire ropes in a clean well ventilated, dry location preferably undercover and protected from extremes of temperatures.

If site conditions are such that undercover storage is not possible cover the rope with a waterproof cover and support clear of the ground.

Rotate stored wire ropes, reels or coils regularly to prevent migration of the rope lubricant, particular in warm environments.

Be aware that subjecting wire ropes to extremes of temperature as can affect the in service performance, high storage temperatures can reduce the effective strength of the rope.

## **SAFETY**

Running wire ropes are hazardous and should be guarded or personnel should be prevented access to them whilst in motion.

Wire ropes develop broken strands during their working life which present a hazard to maintenance personnel, always wear suitable hand and eye protection when handling ropes.

Take care when unfastening a coiled rope as the inherent springiness when released may cause it to strike attendant personnel or other equipment causing damage or injury.

Take care when removing worn, damaged or failed ropes from equipment as they may be tightly coiled, grossly distorted and still retain their springiness.

## **IN SERVICE INSPECTION AND MAINTENANCE**

Wire ropes used for lifting operations should be regularly inspected by a competent person and inspection records kept upto date.



Inspections should not only concentrate on the rope but also extend to the condition of sheaves, drums, guides etc.

Decisions on whether a wire rope is suitable for continued service should only be made by a competent person.

**IF IN DOUBT REPLACE THE ROPE.**

**PAGE INTENTIONALLY BLANK**

**PAGE INTENTIONALLY BLANK**

# RP400 55 LITRE (12 GALLON) WATER TANK

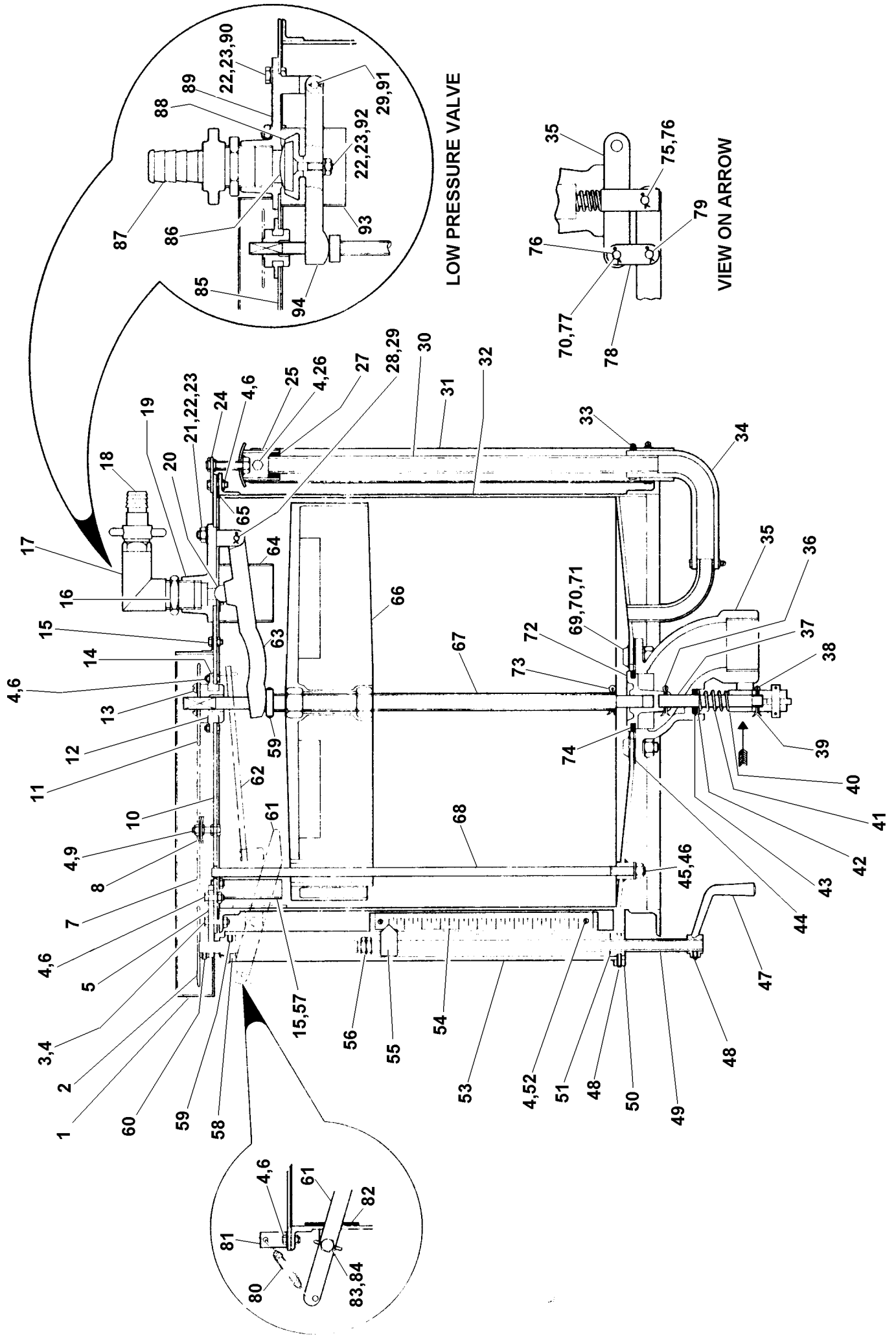

# RP400 12 GALLON WATER TANK

1	CR540138	Chain Guard	1
2	CR200010	Adjusting Rod Pinion	1
3	11S02C	Screw Set M6 x 25	1
4	7S02	Nut M6	28
5	CR530132	Adjusting Rod Bearing	1
6	11S02A	Screw Set M6 x 16	17
7	CR200058	Simple Chain 8mm Pitch	1
8	CR540147	Chain Guide	1
9	8S02B	Guide Bolt M6 x 30	2
10	CR450012	Tank Lid	1
11	CR200009	Centre Bearing Pinion	1
12	CR210029	Centre Bearing	1
13	16S07A	Round Head Slit Screw M6 x10	3
14	CR210022	Centre Bearing Housing	1
15	11S02AA	Screw Set M6 x 12	5
16	122S07	1" BSP Equal Adaptor	1
16A	100S08	Seal Bonded 1"	1
17	128S06	1" BSP Swept Elbow	1
18	CR510328	Hose Connection	1
18A	129S06F	1 " BSP Swept Hose Tail Adaptor (Alt to Items 17/18)	1
19	CR210020	Inlet Valve Body (High Pressure)	1
20	CR570010	Inlet Valve (High Pressure)	1
21	11S04B	Screw Set M10 x 20	4
22	7S04	Nut M10	4
23	17S05	Spring Washer M10	4
24	CR540141	Gauge Glass Cover Support	1
25	CR260112	Gauge Glass Cover	1
26	8S02F	Bolt M6 x 50	1
27	CR510349	Gauge Glass Cover Rubber	1
28	CR520055	Valve Lever Fulcrum Pin	1
29	CR480215	Brass Split Pin	2
30	CR450025	Gauge Glass	1
31	CR540142	Gauge Glass Guard	1
32	CR450010	Tank Body	1
33	97S07	Hose Clip (No 1) 25-35mm	3
34	CR510321	Gauge Glass Connecting Pipe	1
35	CR510024	Outlet Pipe	1
36	CR480214	Brass Split Pin	1
37	CR520057	Outlet Valve Spindle	1
38	44S03E	Split Pin	1
39	CR530095	Valve Spindle End	1
40	CR530096	Spindle End Distance Piece	1
41	CR330015	Outlet Valve Spring	1
42	CR490031	Valve Spindle Washer	1
43	CR560019	Outlet Valve Seal	1
44	CR560030	Outlet Pipe Joint	1
45	253S04	Nut 3/8" B.S.W	1
46	10S03	Flat Washer 3/8"	1
47	CR210028	Adjusting Rod Handle	1
48	68S03AF	Socket Set Screw M6 x 12	2
49	CR520016	Indicator Adjusting Rod	1
50	CR530262	Guide Tube Support	1

# RP400 12 GALLON WATER TANK

51	CR660005	Guide Tube Bush	1
52	16S07B	Round Head Slit Hd Screw M6 x 16	2
53	CR3530100	Indicator Guide Tube	1
54	CR470004	Indicator Scale	1
55	CR210025	Indicator	1
56	253S05	Check Nut 1/2" B.S.W.	2
57	CR540311	Splash Guard	1
58	CR630357	Guide Tube Collar	1
59	68S03AD	Screw Set Skt Head M6 x 6	3
60	68S02AE	Screw Set Skt Head M5 x 8	1
61	CR540137	Release Lever	1
62	CR540136	Locking Plate	1
63	CR210026	Inlet Valve Lever	1
64	CR540257	Splash Guard	1
65	CR560137	Sealing Strip	1
66	CR450008	Float	1
67	CR520051	Float Centre Spindle	1
68	CR520053	Float Guide Spindle	1
69	68S06E	Screw Set Skt Head M12 x 30	6
70	7S05	M12 Nut	7
71	17S06	M12 Spring Washer	6
72	CR210027	Outlet Valve	1
73	CR480213	Brass Split Pin	1
74	CR570011	Outlet Valve Rubber	1
75	CR520058	Operating Handle Pin	1
76	4S03B	Split Pin	5
77	CR520056	Link Fulcrum Bolt	1
78	CR530097	Link	1
79	CR520049	Link Pin	1
80	CR330016	Release Lever Spring	1
81	CR540260	Cleat	1
82	CR570081	Rubber Splash Guard	1
83	11S04C	Screw Set M10 x25	1
84	177S05	M10 Wing Nut	1

## LOW PRESSURE VALVE ONLY

85	CR090979	Tank Lid	1
86	CR570015	Inlet Valve Rubber	1
87	130S06G	Hose Connection	1
88	CR210230	Inlet Valve	1
89	CR210228	Inlet Valve Body	1
90	11S04C	Screw Set M10 x 25	6
91	CR520439	Fulcrum Pin	1
92	52S04J	Screw Set Csk Skt M10 x 45	1
93	CR540377	Splash Guard	1
94	CR210229	Inlet Valve Lever	1
22	7S04	Nut M10	7
23	17S05	Spring Washer M10	7
29	CR480215	Brass Split Pin	2

# RP400 3/4" BSP WATER TANK HYDROBOT ASSEMBLY

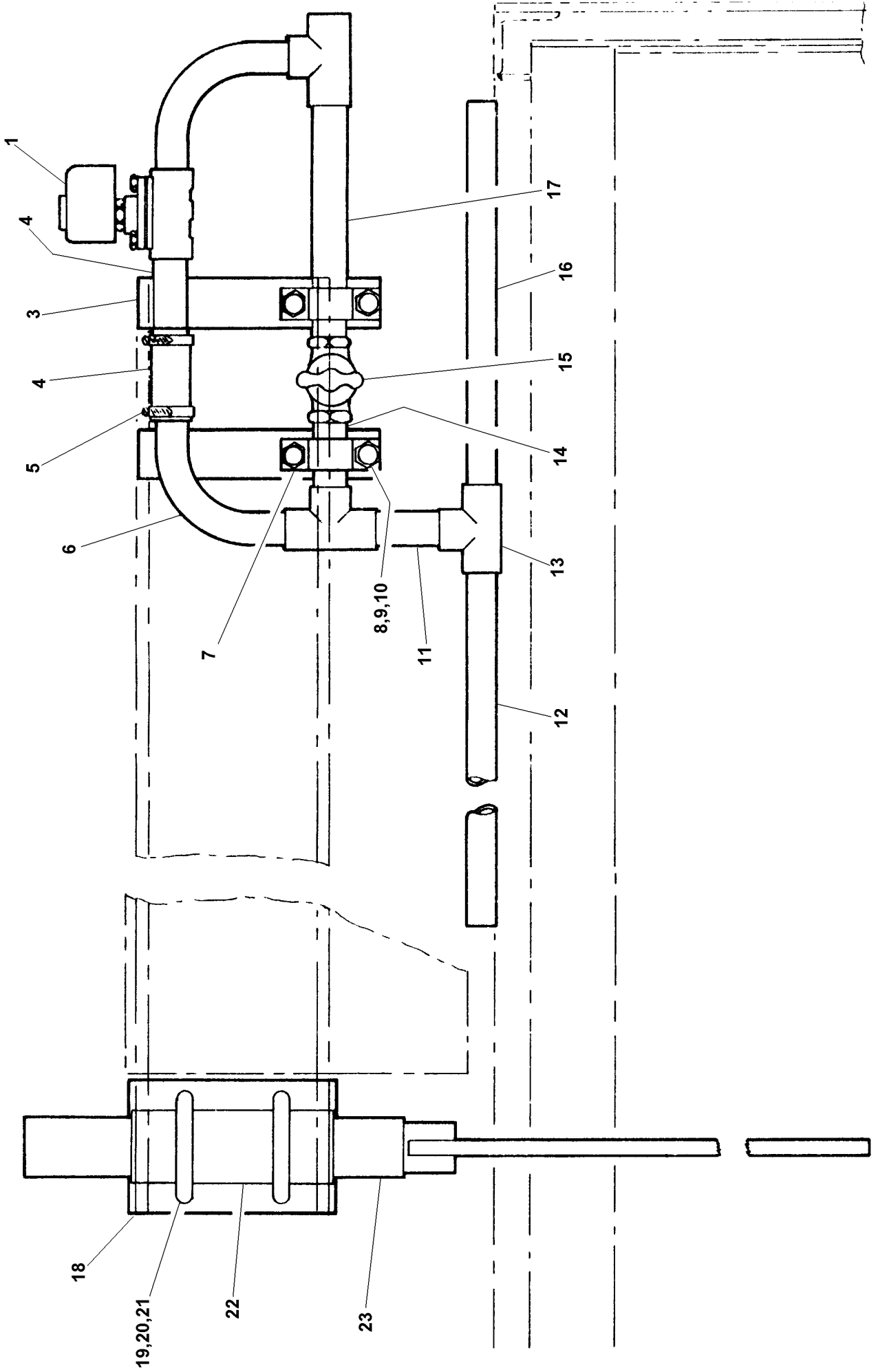

# RP400 3/4" BSP HYDROBOT

1	CR450024	Solenoid Valve	1
*	CR220684	Solenoid Coil for Item 1	1
*	CR450066	Spare Part Kit for Item 1	1
2	CR530341	Pipe	1
3	CR532261	Fixing Support Plate	2
4	CR510455	Rubber Pipe	1
5	CR243005	Hose Clip	2
6	CR510091	Pipe Bend	2
7	CR532262	Fixing Pipe Support Clamp	2
8	11S04B	Screw Set M10 x 20	4
9	7S04	Nut M10	4
10	17S05	Spring Washer M10	4
11	CR530340	Pipe	1
12	CR450064	Spray Pipe (Long)	1
13	CR510092	Tee Piece	3
14	CR530340	Pipe	1
15	CR450028	Stop Valve	1
16	CR450065	Spray Pipe (Short)	1
17	CR530338	Pipe	1
18	CR532264	Probe Support Plate	1
19	CR532263	U' Bolt	2
20	7S05	Nut M12	4
21	17S06	Spring Washer M12	4
22	CR530120	Probe Clamp	1
23	CR261541	Hydrobot Probe	1

\*Not Illustrated



**PAGE INTENTIONALLY BLANK**

**PAGE INTENTIONALLY BLANK**

**OPERATING  
AND  
MAINTENANCE MANUAL**

**SECTION 6**

**ELECTRICAL SYSTEM**

## **ELECTRICAL INFORMATION**

1. The mixing pan and mixing star motors should be interconnected in the control to operate at the same time, as it is important that both are working before a mix is added. Ensure that suitable overloads are fitted. The mixing pan and mixing star rotate anti-clockwise when looking from the top.

**NOTE:** With motors 5.5 kw and above, use Star Delta Starters. Below this, use Direct on Line Starters.

2. When a loader is attached a direct on line reversing starter is required complete with suitable overloads. The loader winch rotates anti-clockwise looking from the rope drum end and when the raise button is pressed.

The upper and lower limit switches are positioned to break the electrical supply to the loader motor when the loading hopper is in the required position at the top and bottom of the runway.

3. The door control solenoid has to be energised when the mixer door is required in the open position.

It is advisable to mount the starters away from the machine on supports free from vibration.

4. **IMPORTANT NOTICE:** All work on plant electrics including control panel circuits to be under taken by a suitably qualified and competent electrical person.

**WIRING DIAGRAM FOR 'RP400' CUMFLOW MIXER WITH LOADER, AIR OPERATED DISCHARGE GEAR & WATER TANK FOR USE WITH AEI STARTERS AND ELECTRIC MOTORS**

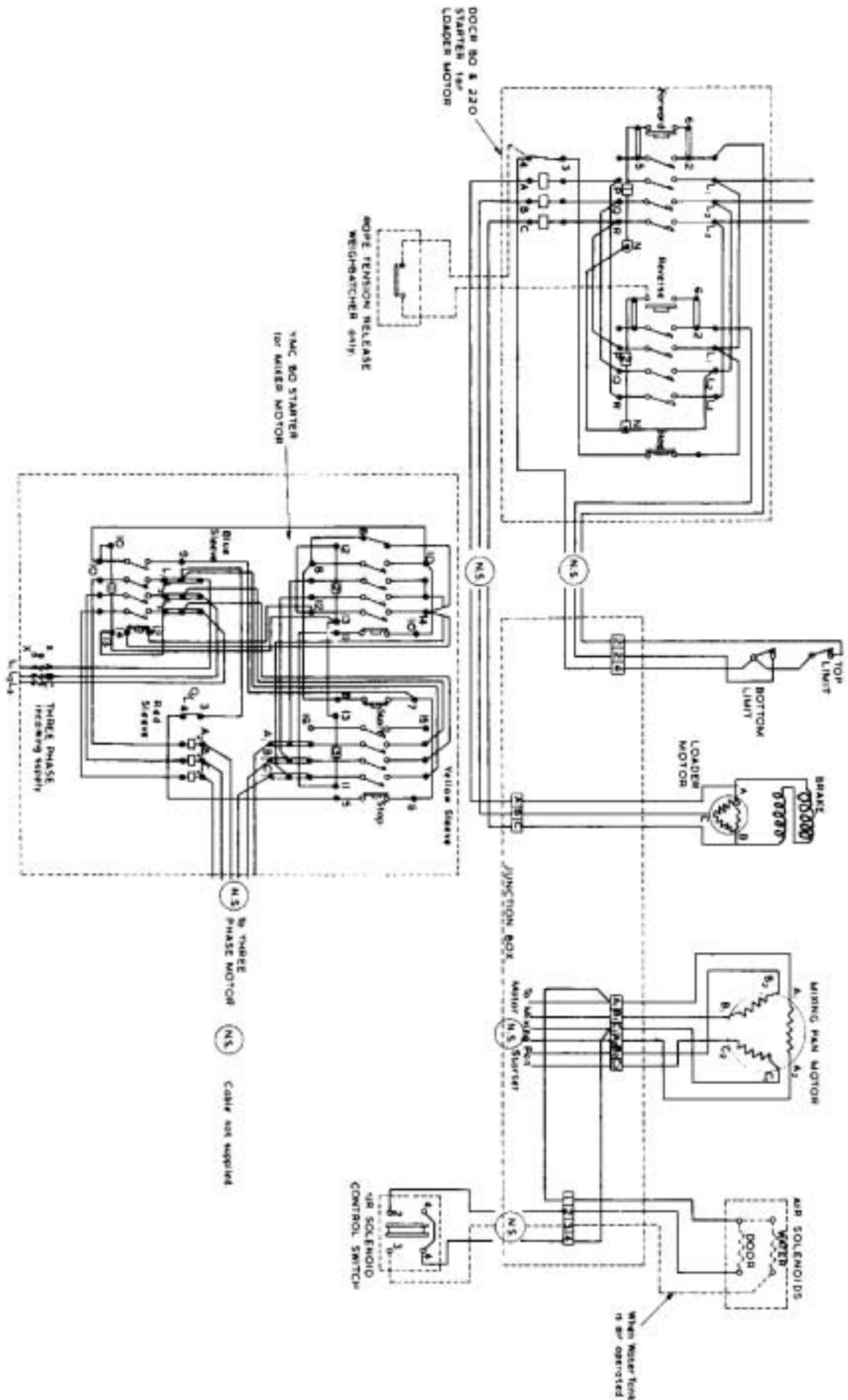

# WIRING DIAGRAM BROOKS STARTERS

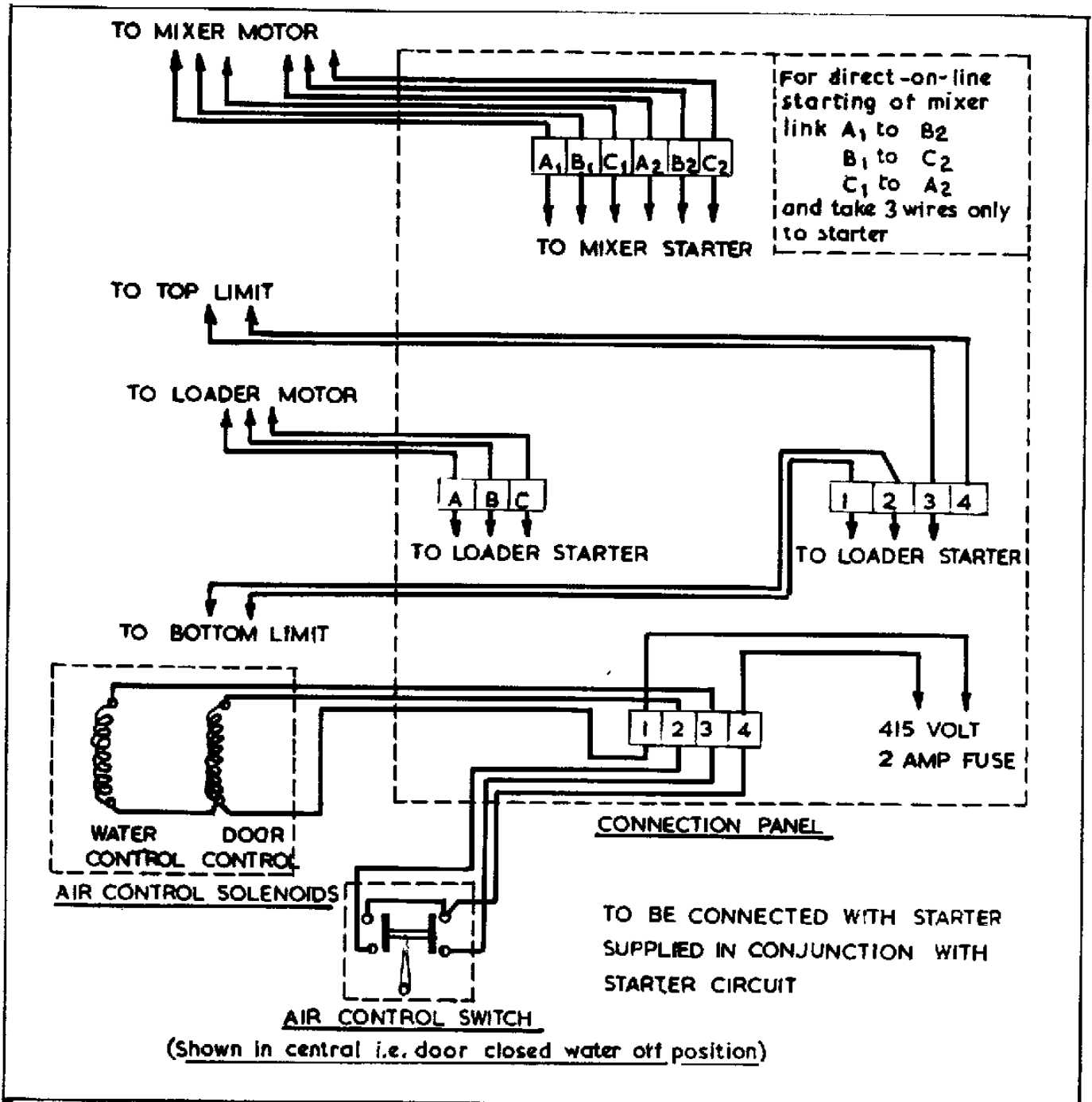

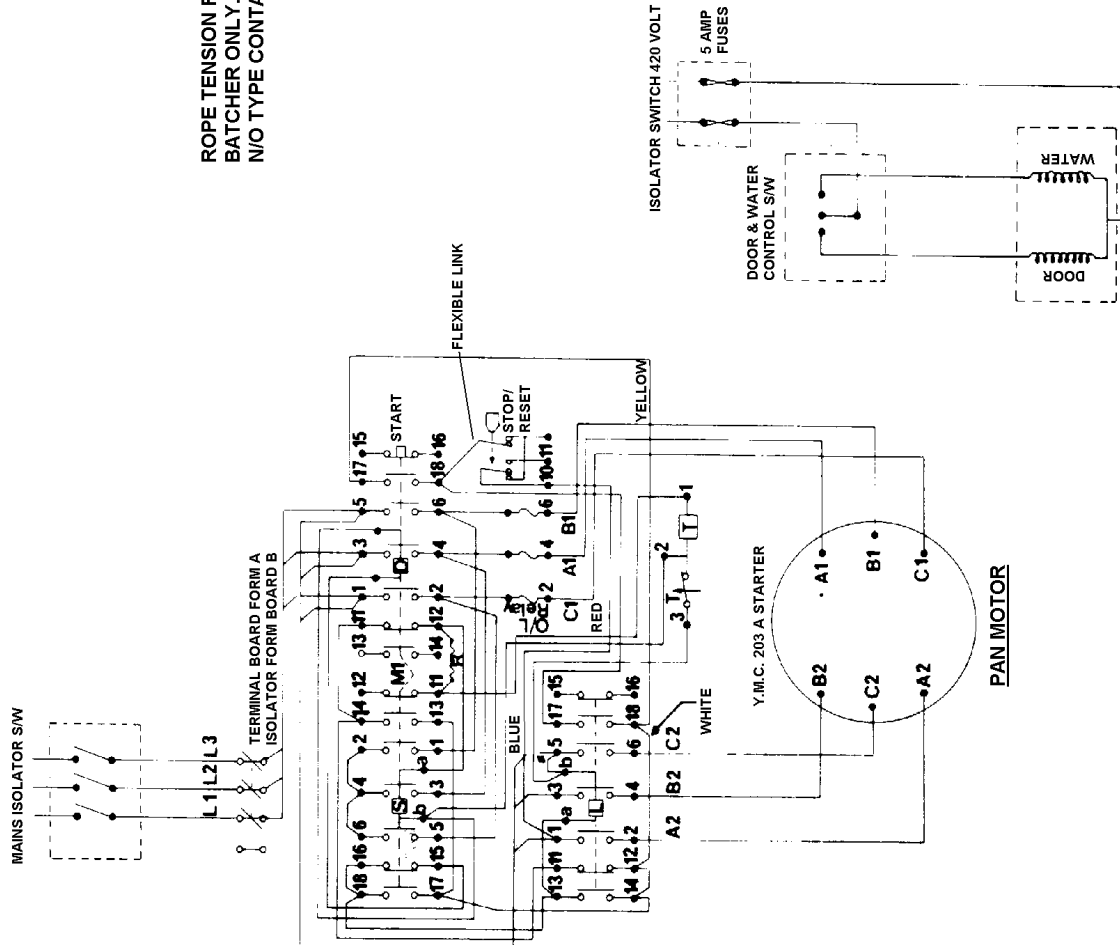
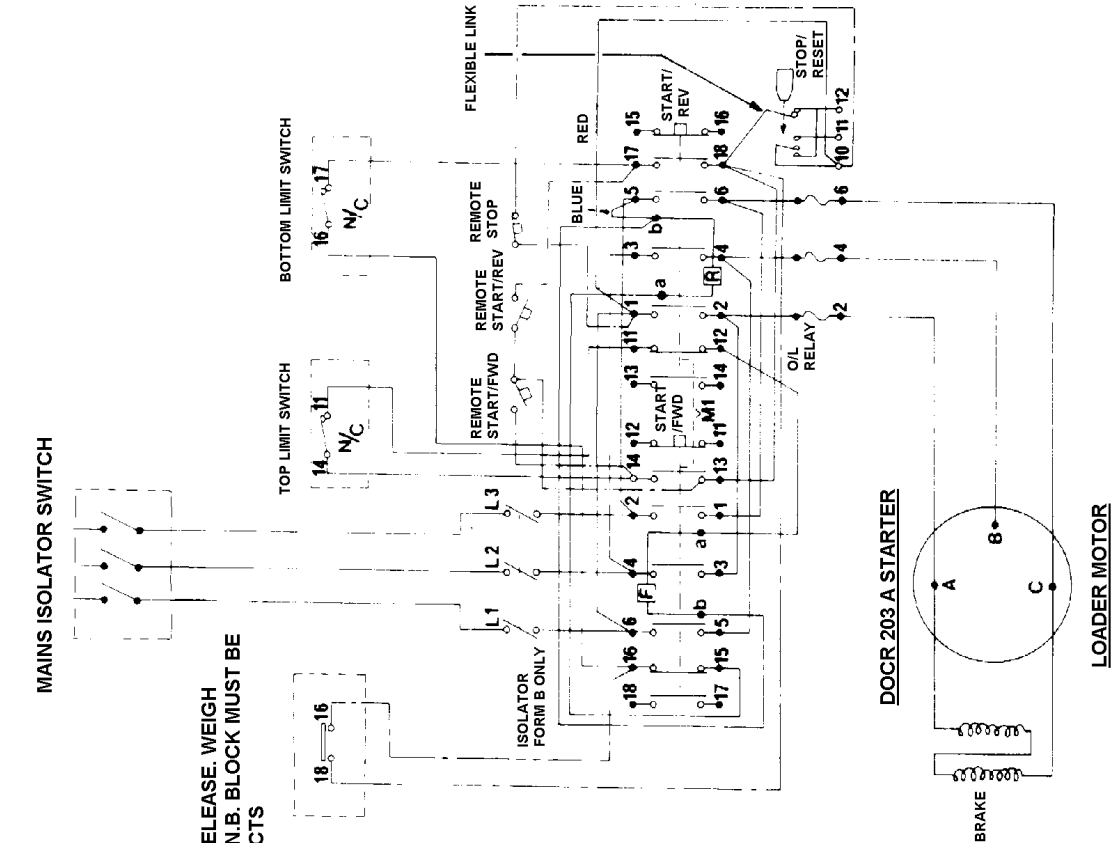

# RP400 FLENDER MOTOR WIRING DIAGRAM

MOTORS UPTO & INCLUDING 4.0Kw

SEE SEPARATE PAGE FOR MOTORS

5.5Kw AND ABOVE

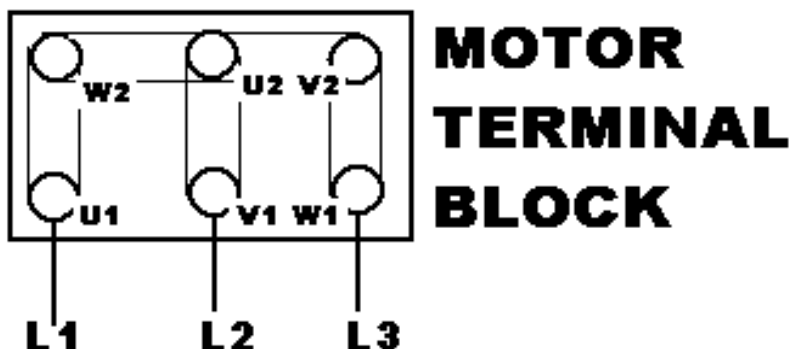

**TO REVERSE DIRECTION  
OF ROTATION CHANGE  
OVER ANY TWO SUPPLY  
LEADS**

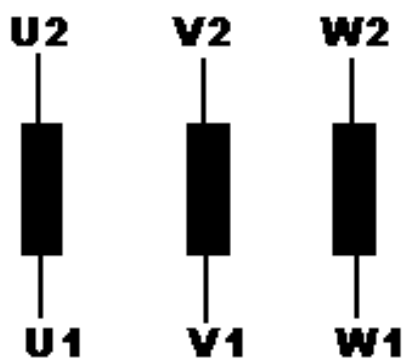

<u>SUPPLY</u>	<u>METHOD OF START</u>	<u>CONNECTION STAR</u>	<u>LINK</u>
415/3/50 380/3/50	DIRECT ON LINE		W2-U1 U2-V1 V2-W1

UPTO & INC 4.0Kw



# RP400 FLENDER MOTOR WIRING DIAGRAM

## MOTORS 5.5Kw AND ABOVE ONLY

SEE SEPARATE PAGE FOR MOTORS

4.0Kw & BELOW

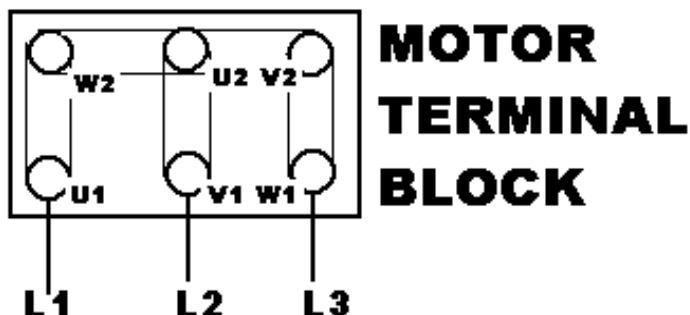

**TO REVERSE DIRECTION  
OF ROTATION CHANGE  
OVER ANY TWO SUPPLY  
LEADS**

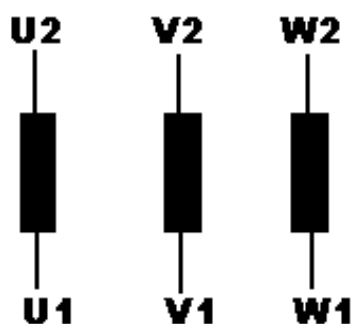

**STAR DELTA STARTING  
NO LINKING REQUIRED**

<u>SUPPLY</u>	<u>METHOD OF START</u>	<u>CONNECTION DELTA</u>	<u>LINK</u>
415/3/50 380/3/50	DIRECT ON LINE		W2-U1 U2-V1 V2-W1

5.5Kw & ABOVE

**PAGE INTENTIONALLY BLANK**

# INTERLOCK DOOR MECHANISM

NOTE SUPPLY WITH FOLLOWING ITEMS

1. KEY STANDARD MLK100

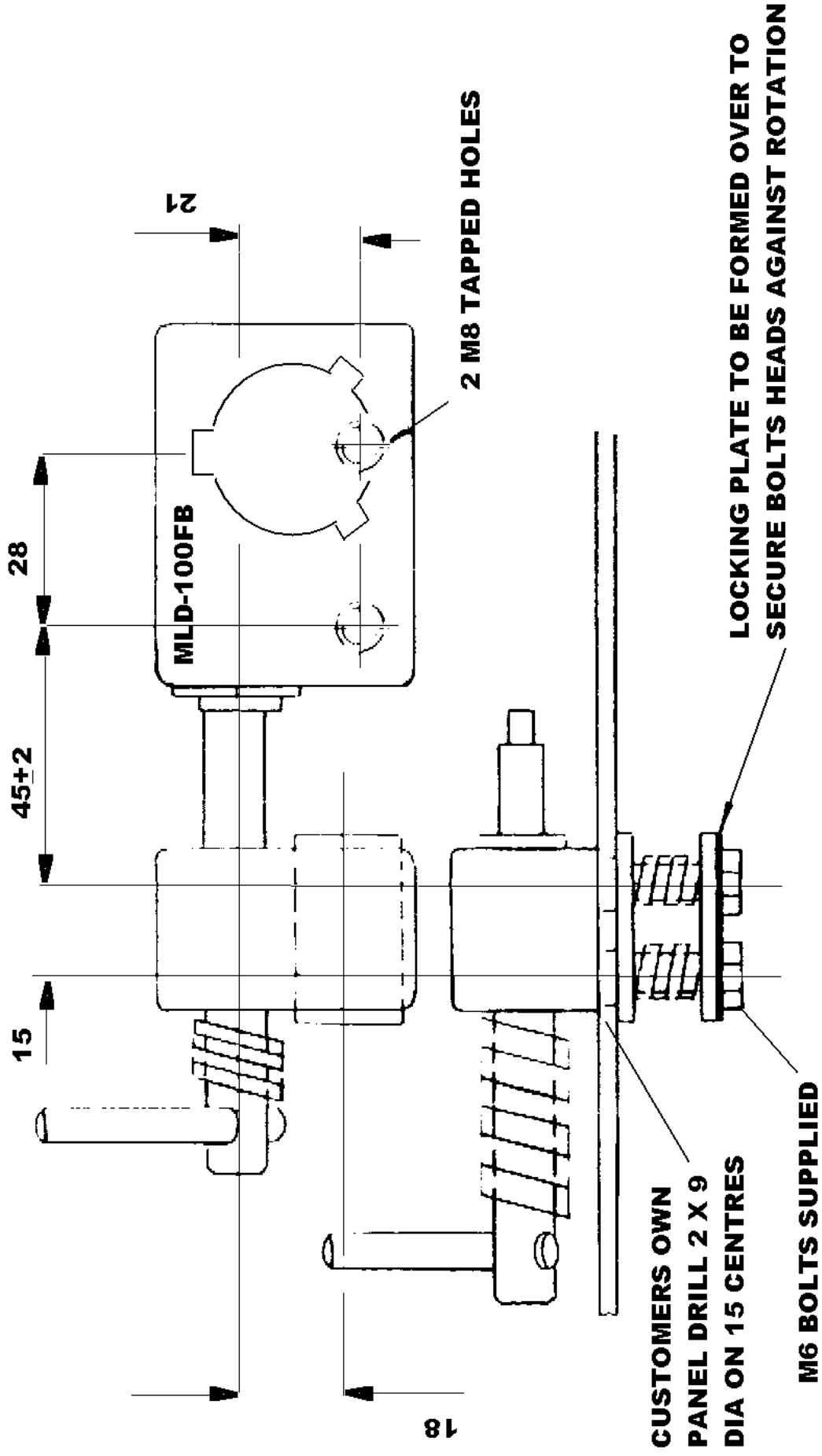

# MISTURA DOOR INTERLOCK MECHANISM

1	CR719072	Interlock Door MLD100FB	A/R
2	CR229093	Key MLK100A Code A	A/R
2A	CR229094	Key MLK100B Code B	A/R
2B	CR229124	Key MLK100C Code C	A/R
3	CR229125	Cap Dust MLM100	A/R

When ordering replacement keys quote code of interlock mechanism

# MISTURA DOUBLE KEY EXCHANGE INTERLOCK

1	CR229191	Basic Double Key Interlock MLA131	1
2	68S03D	Cap Screw M6 x 25	2
3	68S04D	Cap Screw M8 x 25	2
4	CR229093	Key MLK100A Code A	1
5	CR229094	Key MLK100B Code B	1
6	CR229124	Key MLK100C Code C	1
7	CR229125	Cap Dust MLM100	2

**OPERATING  
AND  
MAINTENANCE MANUAL**

**SECTION 7**

**PNEUMATIC SYSTEM**

## SHUTDOWN PROCEDURE – PNEUMATICS

(This procedure to be read in conjunction with electrical procedure – see section six).

### **We Recommend**

A lockable dump valve be fitted in the feed line to our mixing equipment (see drawing below).

Prior to any maintenance, the mixing equipment must be isolated using the above padlockable shut off valve. When put to the dump position, air will be allowed to vent to atmosphere removing the potential stored energy hazard. With the system in this condition, the mixer door will open and discharge blade will lower.

### **Important**

Prior to entry into mixing pan, the air supply must be exhausted and isolated as above. Check door is fully open and the discharge blade rests upon pan base before commencing maintenance/cleaning. Also check that the pressure gauge reads zero.

Should blade or door remain up or partially closed, it is imperative that the cause is investigated and dealt with prior to entering mixing pan. See maintenance section.

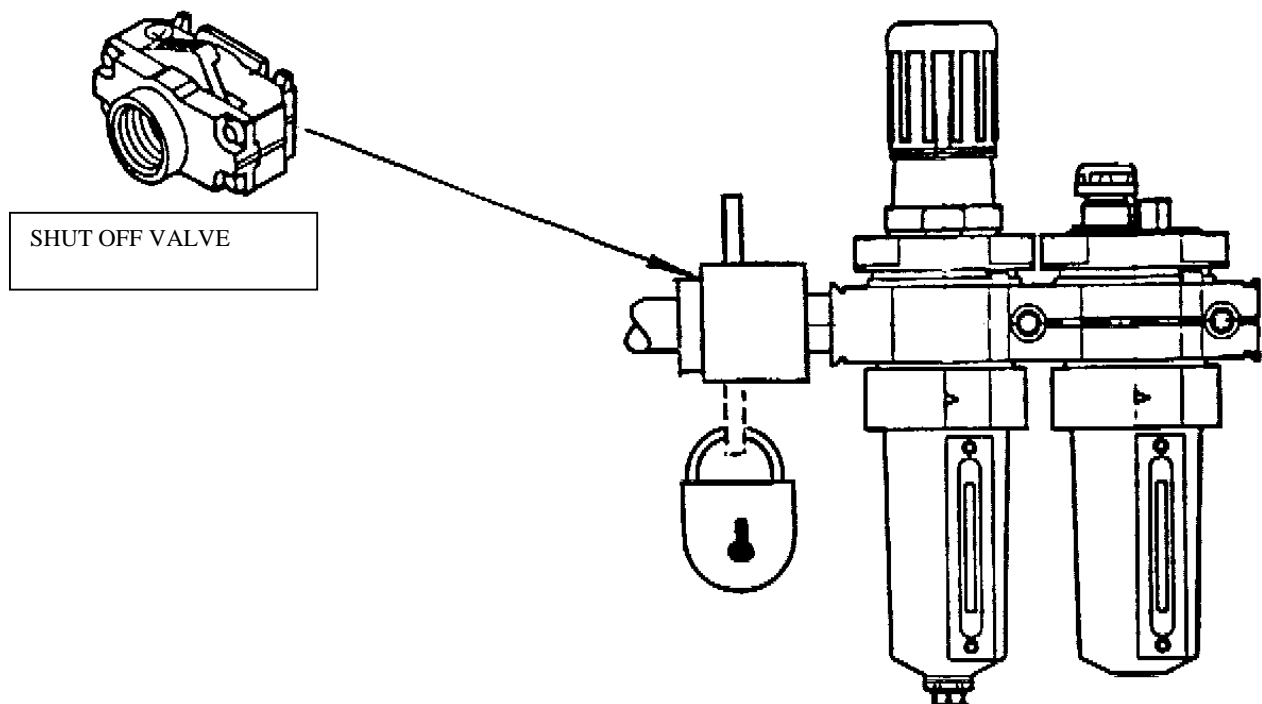

# RP400 PNEUMATIC SYSTEM SCHEMATIC

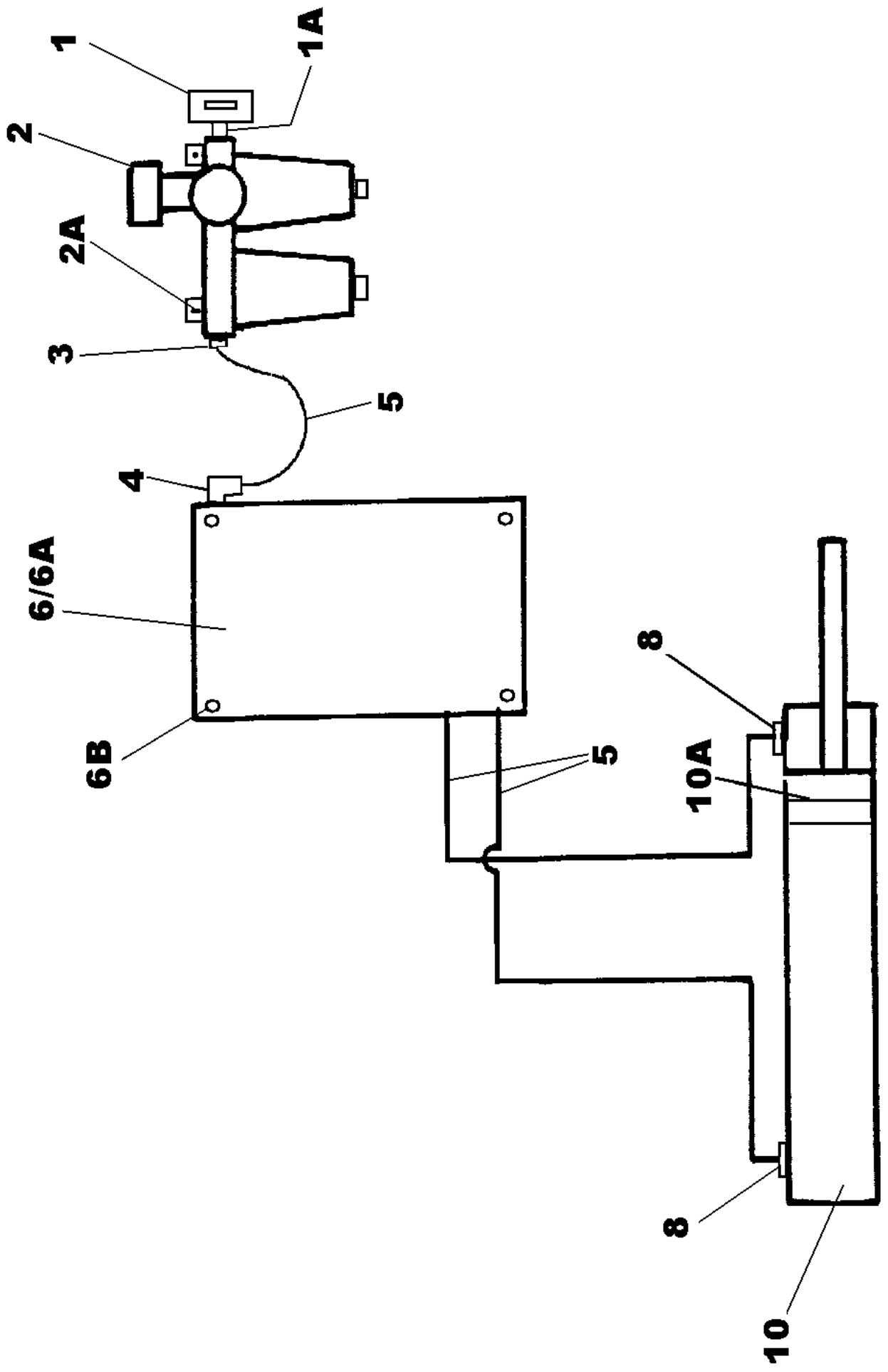



## RP400 PNEUMATIC CIRCUIT (PLASTIC PUSH IN FITTINGS)

1	CR119347	Shut Off Valve	1
1A	191S03	1/2"-1/2" BSP Male/Male Nipple Adaptor Tapered	1
2	CR110005	Air Service Unit/Regulator/Lubricator	1
2A	11S03C	Screw Set Air Unit/Regulator Retaining	4
2B	267S05	Washer Flat	8
2C	17S04	Washer Spring	4
2D	7S03	Nut	4

Available spares for Air Service Unit itemised below:

*	CR119373	Bowl Regulator	1
*	CR119374	Bowl Lubricator	1
*	CR119375	Filter Repair Kit	1
*	CR119376	Filter Element	1
*	CR119377	Lubricator Repair Kit	1
*	CR119378	Pressure Gauge	1
*	CR119379	Bracket Mounting	2
*	CR119380	Knob Regulator	1
3	CR119261	1/2" BSP Male x 12mm Fem Push In Straight Adaptor	1
4	CR119129	3/8" BSP Male x 12mm Female Push In Elbow	1
5	CR119119	12mm Diameter Plastic Air Hose	A/R
6	CR119210	Electric/Pneumatic Solenoid Control Box	1
6A	CR119346	Electric/Pneumatic Solenoid Control Box 60 Hz	1
6B	11S03C	Screw Set Control Box Retaining	4
6C	267S05	Washer Flat	8
6D	17S04	Washer Spring	4
6E	7S03	Nut	4
8	CR119129	3/8" BSP Male x 12mm Female Push In Elbow, Discharge Door Cylinder, both ends	2
10	CR110298	Air Cylinder Discharge Door	1
10A	CR110325	Seal Kit For Item 10	1
10B	CR119369	Air Cylinder Alternative to Item 10 use with item 10C	1
10C	CR11370	Magnetic Reed Switch, Used with Item 10B not illus	2
12	V2003253	Cable Tie Nylon Long (not illustrated)	A/R
13	V2003111	Cable Tie Nylon short (not illustrated)	A/R
14	CR119215	M12 Female- M12 Male Push In Elbow, if required	A/R
15	CR119239	Compressor 24 Litre Reciever No Illustrated	1
16	CR119144	Adaptor 1/4" B.S.P.- 12mm Push In Fitting Not Illus	1
17	CR119153	Hose Clip Double (not illustrated)	8
18	CR119288	Hose Clip (not illustrated)	2
19	CR119289	Screw Self Tapping (not illustrated)	10

The following alternative items are used to reduce from 12mm diameter Air Hose to 8mm diameter Air Hose if required

CR119208	M12 Male - M8 Female Straight Push In Reducer	A/R
CR119133	8mm Diameter Plastic Air Hose	A/R

# RP400 AIR CONTROL BOX EARLY TYPE

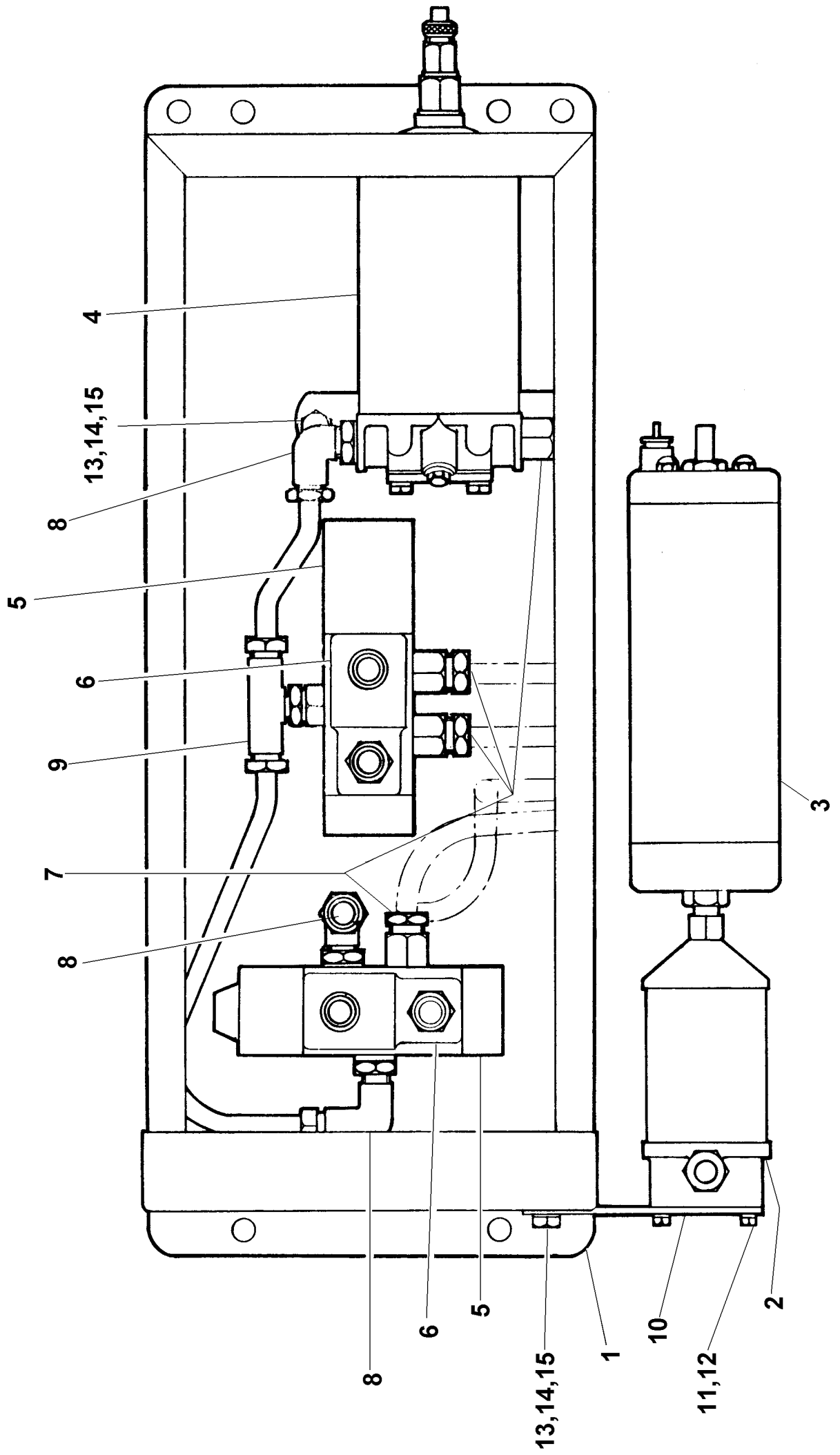

# RP400 AIR CONTROL BOX EARLY TYPE

1	CR541107	Air Control Box		1
2	CR110284	Air Filter		1
3	CR110283	Automatic Drain Valve		1
4	CR110014	Lubricator		1
5	CR110210	Solenoid Valve		2
6	*	Solenoid Coil		2
7	CR510125	Straight Connector		5
8	CR510109	Elbow		4
9	CR510546	Tee Connector		1
10	CR541108	Filter Support Bracket		1
11	CR241478	Filter Support Screw		4
12	CR490037	Washer		4
13	CR242130	Bolt		4
14	CR242901	Nut		4
15	CR490103	Washer		4
16	CR242135	Valve Retaining Bolt	(Not Illustrated)	4
17	CR490103	Washer	(Not Illustrated)	4

\* When Ordering Coils Please Quote Voltage and Cycles.

# RP400 AIR LUBRICATOR & AUTOMATIC DRAIN VALVE EARLY TYPE

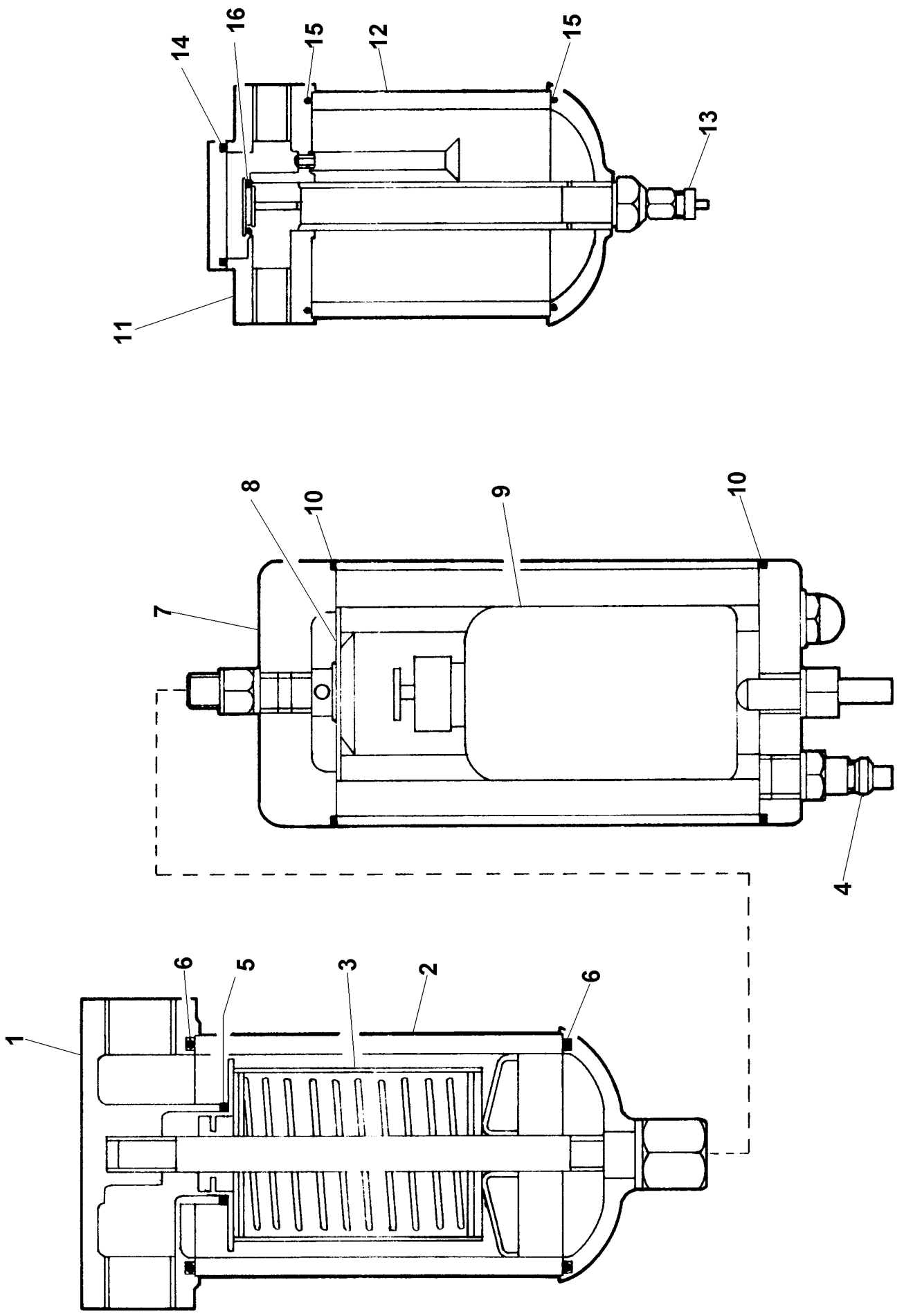

# RP400 FILTER/AUTOMATIC DRAIN VALVE UNIT & LUBRICATOR, EARLY TYPE

*	CR110081	Filter and Automatic Drain Valve Unit Complete -Comprising Items 1 & 7	1
1	CR110284	Filter	1
*	CR110365	Spares Kit for Item 1 Comprising items 3, 5, and 6	1
2	CR110106	Filter Barrel	1
3	CR110366	Filter Element Assembly	1
4	CR110370	Drain Cock	1
5	CR110109	Hears Seal	1
6	CR110108	O' Ring for Barrel	2
7	CR110283	Automatic Drain Valve	1
*	CR110367	Spares Kit for Item 7 Comprising Items 8, 9, and 10	1
8	CR110110	Filter	1
9	CR110368	Float Assembly	1
10	CR110112	Reservoir Gasket	2
11	CR110014	Lubricator	1
*	CR110369	Spares Kit for Item 11 Comprising Items 14,15 and 16	1
12	CR110015	Lubricator Barrel	1
13	CR110018	Drain Cock	1
14	CR110016	Top Cover Gasket	1
15	CR110371	'O' Ring for Barrel	2
16	CR110372	O' Ring for Poppet Valve	1

\* Not Illustrated

# RP400 WATER TANK PNEUMATIC CONTROLS

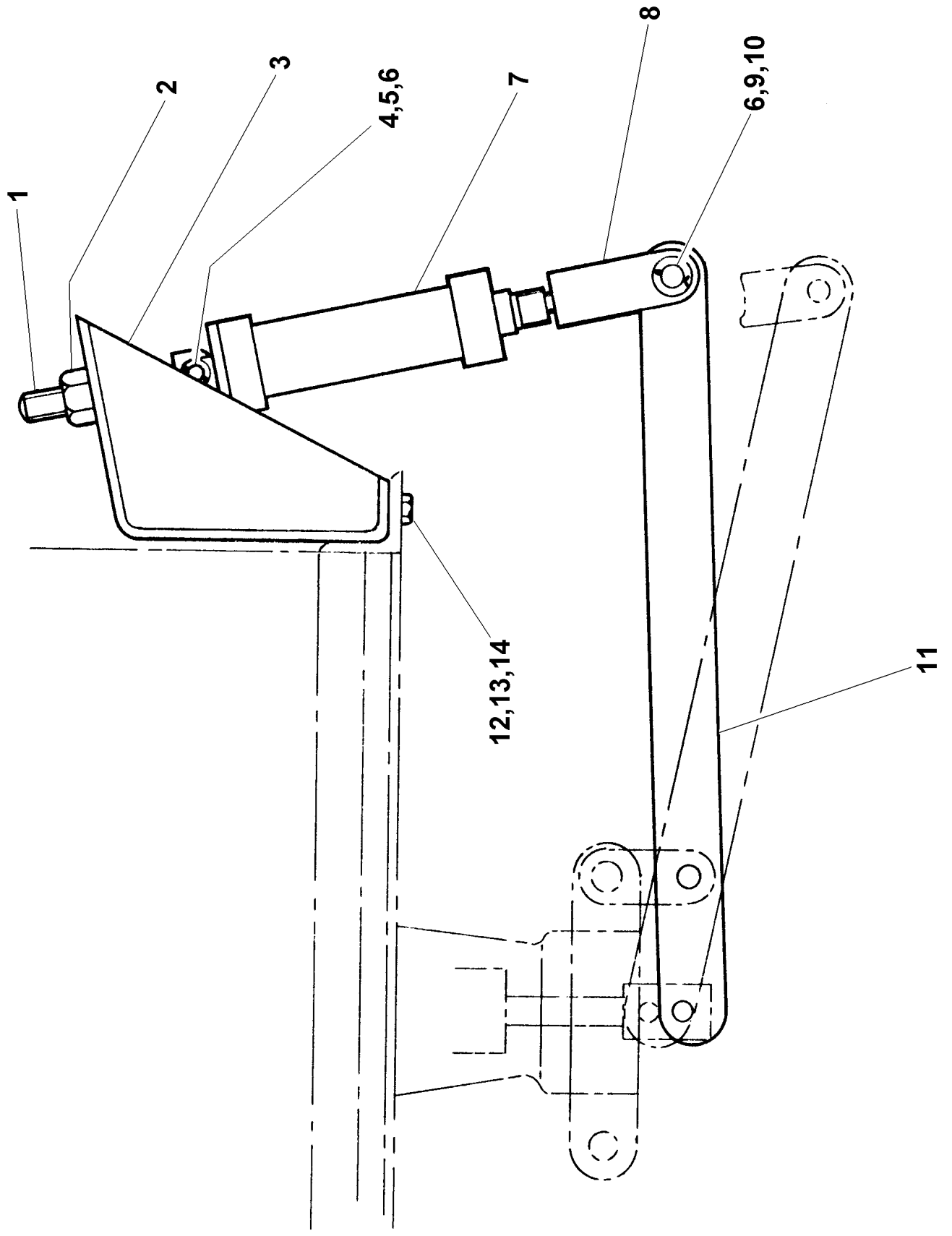

# RP400 WATER TANK PNEUMATIC CONTROLS

1	CR532230	Cylinder Clevis Mount	1
2	7S06	Nut M16	2
3	CR261521	Cylinder Anchor Bracket	1
4	CR520538	Cylinder Pivot Pin	1
5	267S04	Washer Flat M6	2
6	44S01B	Pin Split 1/16" x 3/4"	4
7	CR110275	Air Cylinder	1
8	CR532229	Lever Pivot Holder	1
9	CR520537	Lever Pivot Pin	1
10	267S6	Washer Flat M10	2
11	CR532231	Discharge Lever	1
12	11S04B	Screw Set M10 x 20	2
13	7S04	Nut M10	2
14	17S05	Spring Washer M10	2

# RP400 WATER TANK AIR CYLINDER

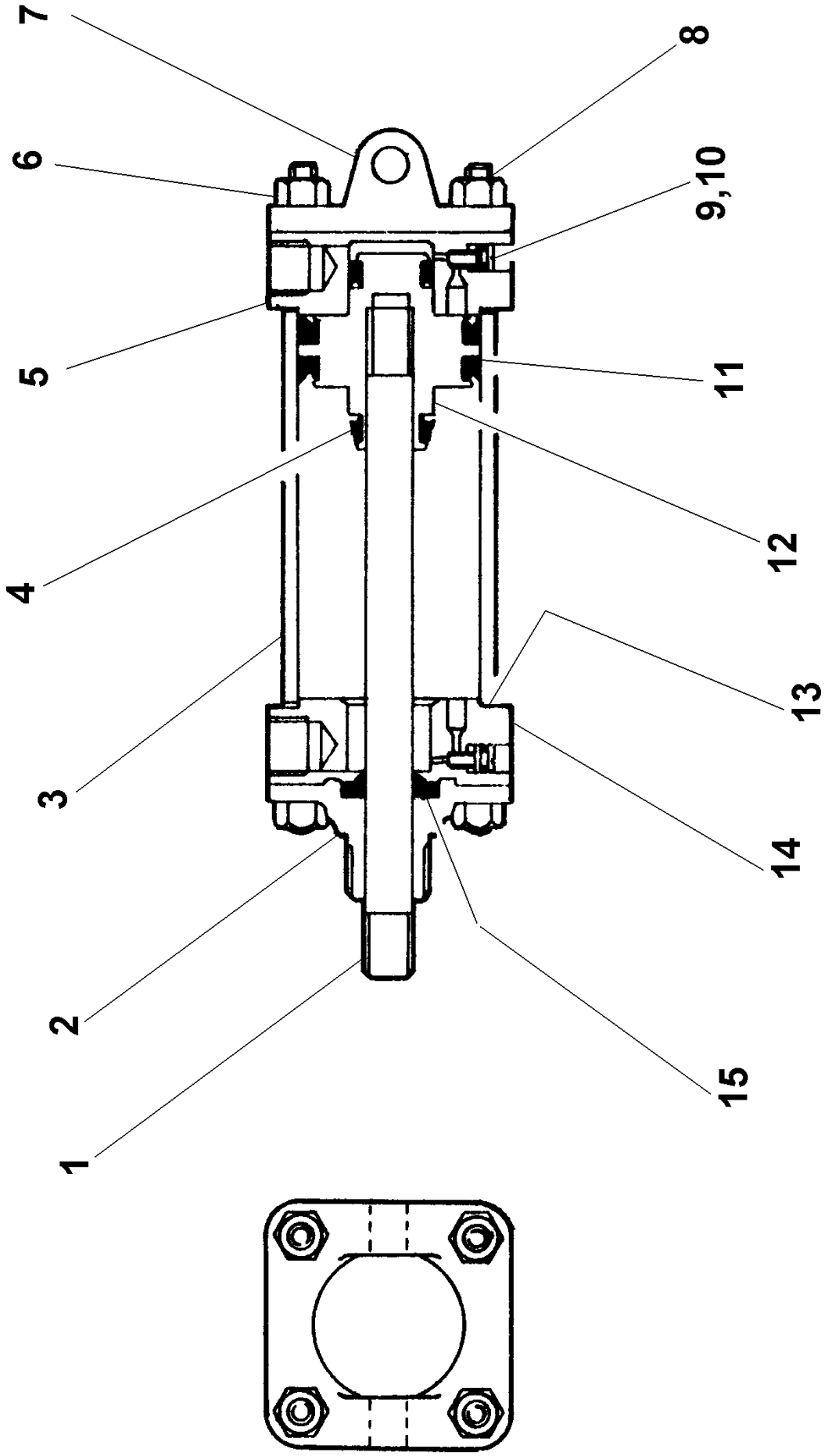



# RP400 WATER TANK AIR CYLINDER

	CR110275	Air Cylinder Assembly Complete	1
	CR110317	Seal Kit for above	1
1	CR110350	Piston Rod	1
2	CR110351	Piston Rod Bearing	1
3	CR110352	Barrel	1
4	CR110353	Cushion Seal	2
5	CR110354	Rear End Cover Assembly	1
6	CR110355	Tie Rod Nut	8
7	CR110356	Rear Clevis Mounting	1
8	CR110357	Tie Rod	4
9	CR110358	Adjusting Screw (Cushion)	2
10	CR110359	Cushion Adjusting Seal	2
11	CR110360	Piston Seal	2
12	CR110361	Piston	1
13	CR110362	Gasket	2
14	CR110363	Front End Cover Assembly	1
15	CR110364	Piston Rod Packing	1

**OPERATING  
AND  
MAINTENANCE MANUAL**

**SECTION 8**

**MISCELLANEOUS**

## **MISCELLANEOUS**

### **8..1 NOISE DETAILS**

Measured in accordance with Directive 79/113EEC at four points around the machine at 1 metre radius and at a height of 1 metre the noise did not exceed 85LPA

**RP400 PAN COVER FOR LOADER WITH SWINGING COVER & TWO INSPECTION COVERS AS SUPPLIED TO HAMPSHIRE GARDEN**

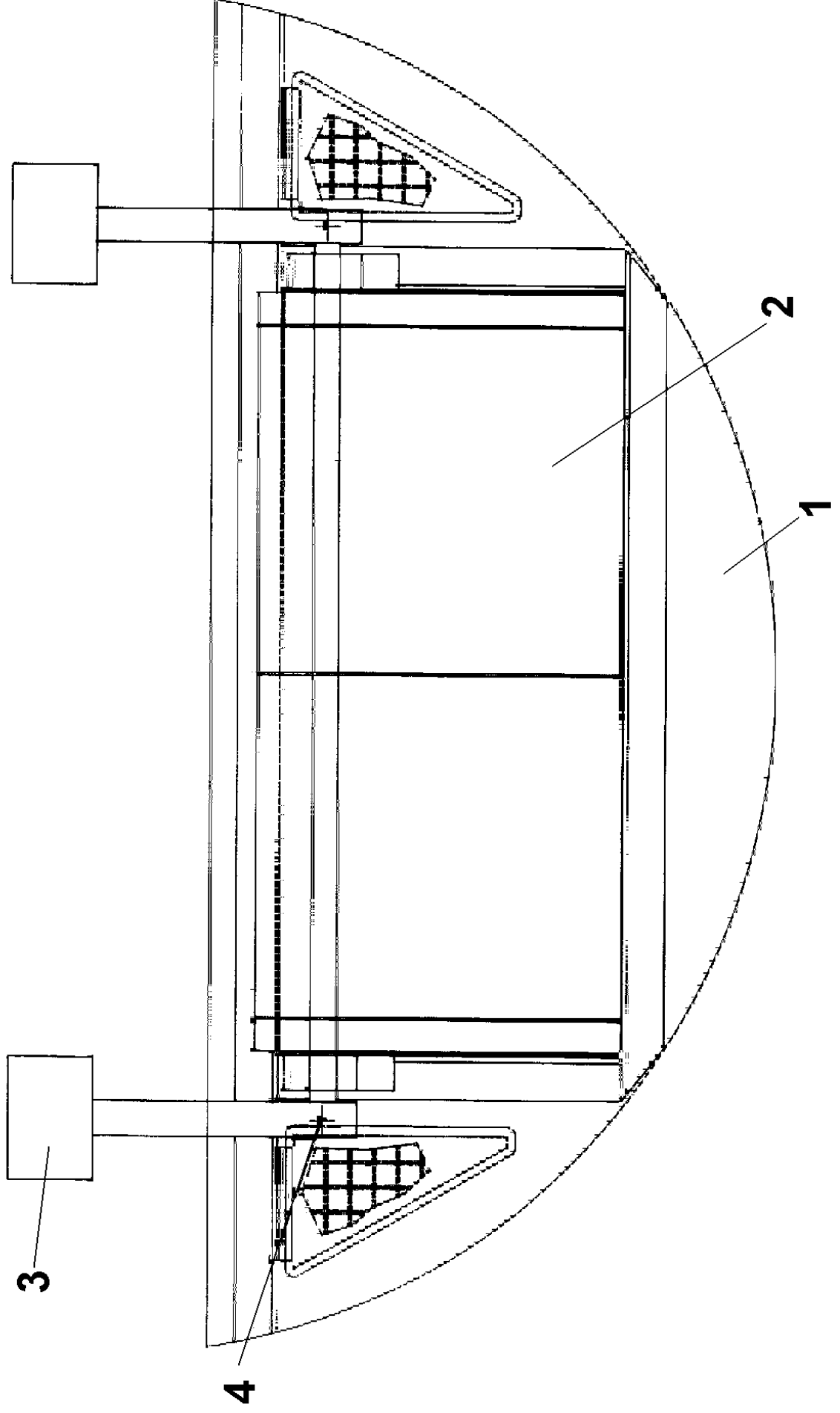

# RP400 PAN COVER FOR LOADER WITH SWINGING LID AND TWO INSPECTION COVERS

CR039006	Pan Cover Assembly with Swinging Lid and Two Inspection Covers, Used with Loader, As supplied to Hampshire Garden	1
----------	---	---

## Comprises of following items

1	CR039005	Cover	1
1A	11S03A	Screw Set Cover Retaining M8 x 16	2
1B	11S03B	Screw Set Cover Retaining M8 x 20	10
1C	17S04	Washer Spring M8	12
1D	267S05	Washer Flat M8	12
2	CR049015	Door Swinging & Frame	1
2A	8S05P	Bolt Door Retaining M12 x 100	2
2B	267S07	Washer Flat M12	4
2C	61S05	Nut Binx M12	2
3	CR059003	Counterbalance Weight	2
4	54S07M	Pin Roll	4
5	10537A02	Catch Toggle overcentre (Not Illustrated)	2
6	10538A02	Plate Fastener (Not Illustrated)	2
7	11S01A	Screw Set M5 x 16	4
8	17S02	Washer Spring M5	4
9	7S01	Nut M5	4

## RP400 WATER SPRAY PIPE (AS Mc/No 6048)

1	CR519014	Water Spray Pipe	1
2	CR519017	Elbow 1.25" M/F	1
3	CR519018	Nipple Barrel 1.25"	1
4			
5	11S02B	Screw Set M6 x 20	3
6	17S03	Washer Flat M6	3
7	267S04	Washer Spring M6	3
8	7S02	Nut M6	3

**PAGE INTENTIONALLY BLANK**

**PAGE INTENTIONALLY BLANK**



**PAGE INTENTIONALLY BLANK**

**PAGE INTENTIONALLY BLANK**