

# DUMPERS

## 4B2500

## 4B3000

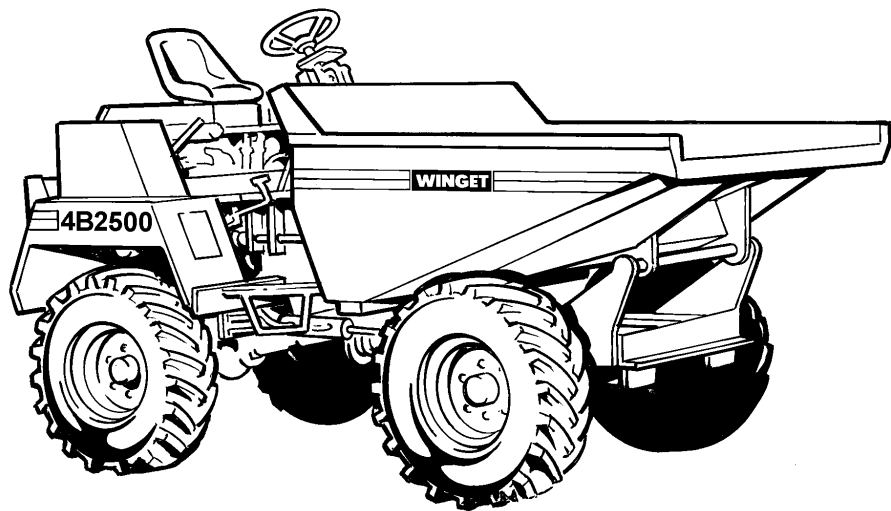

# OPERATORS HANDBOOK & PARTS

Manual V601320

July 2012

# WINGET

WINGET LIMITED, P.O. Box 41, Edgefold Industrial Estate, Plodder Lane, Bolton, BL4 0LS, England  
Tel: +44 (0) 1204 854650 Fax: +44 (0) 1204 854663  
E mail: [parts@winget.co.uk](mailto:parts@winget.co.uk), [service@winget.co.uk](mailto:service@winget.co.uk)  
[www.winget.co.uk](http://www.winget.co.uk)

**CONTENTS**

<i>Section</i>	<i>Page</i>	<i>Section</i>	<i>Page</i>
<hr/>		<hr/>	
<b>INTRODUCTION</b>		<b>SERVICE</b>	
Contents	II	Safe working	3.1
Introduction to the handbook	III	Service schedule chart	3.2
Machine identification	III	Engine	3.4
Warranty terms & conditions	IV	Fuel system	3.6
<hr/>		Air cleaner	3.9
<b>SAFE WORKING</b>		Gearbox	3.10
Machine modification	1.1	Transfer gearbox	3.11
Training	1.1	Propeller shafts	3.12
Running-in	1.1	Battery	3.13
Driving	1.1	Hydraulic system	3.14
Skips and loading	1.3	Greasing	3.19
Towing	1.3	Braking system	3.20
Gradients	1.3	Wheels & tyres	3.21
Hydraulics	1.4	Axles	3.22
Servicing	1.4	<hr/>	
Decal identification	1.6	<b>TECHNICAL INFORMATION</b>	
<hr/>		Dimensions	4.1
<b>OPERATION</b>		Specifications	4.4
Controls layout	2.1	Road speeds	4.5
Running-in a new engine	2.3	Lubricants & fluids	4.5
Pre-start checks	2.3	Skip capacities	4.5
Driving the dumper	2.3	Tyre pressures	4.6
Starting and stopping the engine	2.4	Tyre sizes	4.6
Gradients	2.10	Hydraulic pressure	4.6
Braking	2.10	Wheel nut torque	4.6
Gear selection	2.10	Vibration declaration	4.6
Stopping the dumper	2.10	Main electrical circuit:	4.7
Leaving the dumper	2.10	Road lights, electrical circuit	4.8
Skip operation	2.11	<hr/>	
Towing	2.12	<b>PARTS</b>	
<hr/>		Illustrated parts lists	
		<hr/>	

The contents of this Handbook, although correct at the time of publication, may be subject to alteration by the Manufacturers without notice.

Winget Limited operate a policy of continuous product development. Therefore, some illustrations or text within this publication may differ from your machine.

## THE HANDBOOK

**WARNING** *The Operator must read all the Handbook and fully understand its contents before attempting to operate the machine.*



## THE HANDBOOK MUST NOT BE REMOVED FROM THE MACHINE.

The Handbook should be kept clean and in good condition. Additional copies of the Handbook can be obtained from your Distributor.

The contents of this Operators Handbook are designed as a guide to the machine's controls, operation, working capacities and maintenance. It is not a training manual.

Only trained operators should use this machine. Consult your Distributor for details of authorised training courses.

In this Handbook are notes accompanied by a warning triangle.



**WARNING** *These notes are used to indicate that the procedure being described in the Handbook must be followed to avoid serious injury or death to yourself or others, or damage to the machine.*



*The warnings are also used to protect the machine from unsafe servicing practices.*

Pay particular attention to the warnings given in the Handbook.

If you have any doubts about any aspect of the machine's capability or servicing procedures, you must consult the manufacturer.

## MACHINE IDENTIFICATION

Please record the model and serial numbers of your machine in the spaces provided and quote them when ordering parts.

Model – Year \_\_\_\_\_.

Front axle \_\_\_\_\_.

Dumper serial no. \_\_\_\_\_.

Rear axle \_\_\_\_\_.

Key, start \_\_\_\_\_.

Ram steering \_\_\_\_\_.

Engine \_\_\_\_\_.

Ram, tipping, L.H. \_\_\_\_\_.

Gearbox \_\_\_\_\_.

Ram, tipping, R.H. \_\_\_\_\_.

Transfer gearbox \_\_\_\_\_.

Tyre make & size \_\_\_\_\_.

## WARRANTY TERMS & CONDITIONS

The Manufacturer assures you that if any part of the machine becomes defective due to faulty manufacture or materials within 12 months from the date of purchase, the part will be repaired or replaced under warranty free of charge by any authorised Winget Distributor. Warranty repairs **must** be carried out by Winget Distributors.

This Warranty is given to the first owner and may be transferred to subsequent owners for the balance of the Warranty period.

The Manufacturer's liability only extends to the costs of repair or replacement of the faulty parts and necessary labour charges involved in the repairs. The Company accepts no liability for any consequential loss, damage or injury, resulting directly or indirectly from any defect in the goods.

Items not covered by Warranty and considered to be the customer's responsibility include normal maintenance services; replacement of service items and consumables; replacement required due to abuse, accident, misuse or improper operation; replacement of wearable items e.g. pins, bushes, brake linings, clutch linings etc.

The Warranty will not apply where the equipment is modified, converted, or used for purposes other than those for which it was designed, unless clearance for the modifications etc. have been granted by the Manufacturer, in writing.

The Pre-Delivery Inspection and Warranty Registration Document must be completed correctly and returned to the Manufacturer within 7 days of sale date. Failure to do so may result in the claim being subsequently rejected.

Tyres and tubes are not covered by Warranty, but are covered by the tyre manufacturer's own warranty system which provides against defects in material or workmanship.

Engines are covered separately by the engine manufacturers, and engine warranty repairs must be handled by the relevant engine manufacturers' distributors.

No claim will be considered if other than genuine Winget Limited parts, which must be obtained from Winget Limited via an authorised Distributor, are used to effect a repair, or if lubricants other than those recommended by Winget Limited are used.

The equipment must be serviced in accordance with the service schedules laid down by Winget Limited. Evidence that these have been complied with may be required before Warranty Claims are reimbursed.

The Manufacturer's policy is one of continuous improvement. Winget Limited reserves the right to change specifications without notice. No responsibility will be accepted for discrepancies which may occur between specification of machines and the descriptions contained in publications.

**Safety is the responsibility of all persons working with this articulated dump truck. Think “safety” at all times. *Read and remember the contents of this handbook.***

**The safe working recommendations for specific tasks are found with the instructions for the relevant operation in this Handbook.**

## **MACHINE MODIFICATION**

**WARNING**



Any modifications to the machine will affect its working parameters and safety factors. Refer to the Manufacturers before fitting any non-standard equipment or parts.

The Manufacturers accept no responsibility for any modifications made after the machine has left the factory, unless previously agreed by the Manufacturers in writing; the Manufacturers will accept no liability for damage to property, personnel or the machine if failure is brought about due to such modifications, or fitment of spurious parts.

## **TRAINING**

**WARNING**



Only trained operators should use this machine.

Operators should hold an appropriate full motor vehicle driving licence and undergo both a safety awareness course and a driver training course for site dumpers run by the C.I.T.B. or equivalent body leading to the award of a C.T.A.

It is strongly recommended that operators read the H.S.E. publication “Safe Working with Small Dumpers” which is available from government bookshops (HMSO) or from other bookshops quoting the following number ISBN 011 8836935. Another useful publication is British Standard number BS 6264, “Procedure for Operator Training For Earth Moving Machinery” available from the British Standard Institution.

## **RUNNING-IN**

**WARNING**



While a gradual ‘running-in’ of a new engine is not necessary, it is extremely important that the instructions given in *Section 2 “Operation”* on “Running-in a new engine” should be followed very closely during the first fifty hours of operation.

## **DRIVING**

**WARNING**



**NEVER** use the machine for purposes other than those for which it was designed. This machine was designed to carry loads such as soil, clay, sand, wet concrete, stone or other similar materials. It was not designed to carry loads which may move around in the skip uncontrollably, or to carry any loads or materials which overhang the skip in any way. If in any doubt as to the suitability of this machine for a particular task, contact your nearest Distributor or the Manufacturer for advice.

*ALWAYS* be aware of local and national regulations governing the use of the machine.

*NEVER* commence work with the machine until the “Daily (or every ten hours)” service checks have been made. (*See Service Section for details*)

*ALWAYS* check wheel nut tightness daily.

*NEVER* carry passengers.

Ensure that the seat is securely fixed to the machine. Where seat belt restraints are fitted as part of Rops/Fops protection they must be worn. Check that the seat belt is in good condition, free from cuts and frayed edges.

*ALWAYS* remain in the driving seat whenever the engine is running. Never attempt to operate any controls unless seated.

*ALWAYS* apply the parking brake before leaving the driver’s seat.

*NEVER* dismount with the engine running, and never leave the machine unattended with the key in the starter switch.

When Battery Isolators are fitted they must be activated only when the engine is turned off except in cases of emergency.

Activating a Battery Isolator when the engine is running can result in damage to the electrical components and circuits.

*NEVER* fill the fuel or hydraulic tanks with the engine running.

*ALWAYS* drive only on surfaces that are known to be stable.

*ALWAYS* keep the floor plates and walkways clean.

*NEVER* drive the machine close to the edge of any excavation. Always use effective wheel stops to prevent the machine running close to the edge. Make sure that the stops are in proportion to the size of the wheels and are set sufficiently far enough back from the edge of any excavation to prevent the weight of the load causing a collapse.

*NEVER* adjust the tyre pressures in an attempt to improve traction on soft ground or obtain a softer ride on hard ground. Incorrectly adjusted tyres can affect the steering and handling characteristics.

*NEVER* attempt to free a machine which is ‘bogged down’ by pushing with the bucket of a backhoe loader, tracked excavator or other similar machine.

*NEVER* make unnecessary “crash stops” when travelling at speed, especially in forward direction.

*NEVER* work under an unpropped skip. If the skip was supplied with a special skip support always ensure that it is used.

**SKIPS AND LOADING**

**WARNING** *NEVER* exceed the rated payload. The weights of all loads above skip water level must be checked.



*NEVER* remain on the machine when loading the skip with excavators or loaders. Stop the engine, apply the parking brake, dismount, and stand well clear.

*ALWAYS* ensure that the load is evenly distributed in the skip.

*NEVER* carry loads or heap materials in such a manner as to affect the forward vision.

*ALWAYS* take extra care when tipping non-free running loads, particularly with Rotary Skips and High Discharge machines.

*NEVER* use the skip in a tipped position to bulldoze heaped materials to level or backfill material into excavations.

*NEVER* leave the machine with the skip raised or rotated..

**TOWING**

**WARNING** *NEVER* attempt to tow a dumper before first reading 'Towing the dumper' (see Contents page).



*Dumpers are not designed as towing vehicles; however, trailers may be towed providing that:*

- 1** The combined weight of the trailer and its load does not exceed the specified maximum payload of the dumper (*see specifications*)
- 2** Trailers may be towed in first gear on level dry ground provided a purpose made towing pin is used.
- 3** The dumper skip must be loaded with half the rated payload to ensure tyre adhesion when braking.

*NEVER* attempt to start the engine of a dumper by towing or pushing.

*NEVER* tow loads up, down or across gradients.

**GRADIENTS**

**WARNING** *NEVER* operate on any gradients which exceed 25% (1 in 4), or across gradients which exceed 16% (1 in 6).



*ALWAYS* remember that slippery or loose surface conditions can adversely affect safe machine operation, including braking, particularly on gradients.

*ALWAYS* choose routes that avoid steep, slippery or loose gradients.

*NEVER* coast down gradients. Always negotiate gradients in first gear.

*ALWAYS* drive forwards up gradients when loaded.

*ALWAYS* reverse down gradients when loaded.

*ALWAYS* keep the load facing uphill.

*NEVER* park on a gradient. If this is unavoidable, *ALWAYS* chock the wheels.

*NEVER* attempt to turn on a gradient.

*NEVER* tow up, down or across a gradient.

*NEVER* operate high discharge or rotary skips on gradients.

## HYDRAULICS

**WARNING** *ALWAYS* “Dump” residual pressure from the system before leaving the machine or before carrying out any maintenance or adjustments.



If maintenance work requires the skip to be in the raised position, then it must be raised and supported before dumping the pressure.

Dump pressure by switching off the engine, then moving the hydraulic control lever several times in each direction.

*NEVER* leave the machine unattended with pressure in the system.

*ALWAYS* purge hydraulic rams before commencing work. With the engine running operate the hydraulic control to fully extend and retract the rams.

*ALWAYS* practise the greatest cleanliness in maintaining hydraulic components.

## SERVICING

**WARNING** *ALWAYS* report any defect at once, before an accident or consequential damage can occur.



*ALWAYS* conform to service schedules except where:

- 1 Warning lights or warning indicators call for immediate attention.
- 2 Adverse conditions necessitate more frequent servicing.

*ALWAYS* wear correctly fitting protective clothing. Loose or baggy clothing can be extremely dangerous when working on running engines or machinery.

*ALWAYS*, where possible, work on or close to engines or machinery only when they are stopped. If this is not practical, remember to keep tools, test equipment and all parts of your body well away from the moving parts.

*ALWAYS* “Dump” pressure from the hydraulic system before carrying out any kind of maintenance or adjustment. (**see Service - Hydraulic system**).

*ALWAYS* avoid contact with exhaust pipes, exhaust manifolds and silencers when the engine is running; these can be very hot.

*ALWAYS* work out of doors, or in a well-ventilated area.

*NEVER* run an engine in an enclosed space. Exhaust fumes in enclosed areas can kill.

*ALWAYS* disconnect battery cables and remove battery before using an external charger, carrying out welding repairs or to prevent unauthorised usage when unattended or during a repair.



*NEVER* allow unqualified personnel to attempt to repair, remove or replace any part of the machine, or anyone to remove large or heavy components without adequate lifting tackle.

*NEVER* attempt to modify or repair the ROPS frames or FOPS canopies by welding, drilling or any other means. Attempts to do so will invalidate ROPS/FOPS Certification.

*ALWAYS* obtain advice before mixing oils; some are incompatible. If in doubt drain and refill.

*NEVER* allow oils and fuels to come into regular contact with skin. This can lead to serious skin diseases including, medical evidence suggests, skin cancer. *ALWAYS* wear protective gloves when handling oils and fuels whether topping up, draining or refilling. *ALWAYS* wash hands if oils or fuels come into contact with the skin.

Many liquids used in this machine are harmful if taken internally or splashed into the eyes. In the event of accidentally swallowing oils, fuels, anti-freeze, battery acid etc, *DO NOT* encourage vomiting, seek qualified medical assistance immediately.

*ALWAYS* dispose of waste oils and fuels into waste oil storage tanks. If storage tanks are not available consult your distributor or local authority for addresses of local designated disposal points. It is illegal to dispose of waste oil into drains or water courses or to bury it.

Equipment which includes friction materials will sometimes contain asbestos. When removing friction material dust from components, such as when servicing brakes or clutches, do not blow out with an airline; it could be harmful to inhale the dust. Remove the dust with a vacuum cleaner or wipe clean with a damp rag. Waste should be placed in a sealed container, marked, and disposed of in accordance with local or national regulations.

The accumulated dust found in clutch housings may contain lead/antimony. No food should be eaten at a work place contaminated by this dust. Hands must be washed before eating. Do not blow out dust with an airline.

*NEVER* work under an unpropped skip. ***If the skip was supplied with a special skip support always ensure that it is used.***

*ALWAYS* ensure, when using a starting handle, that it is clean and in good condition. Keep the engine starting dog and the part of the starting handle that mates with it lightly lubricated (*Refer to the Engine Handbook*).

**DECALS**

*Attached to the dumper are several pictorial warning decals.*

*For detailed information on how to safely use the items described by the decals, see the "Safe working, Operation and Servicing" sections of this Handbook.*

**Descriptions of the decals are as follows:**

Fuel tank filling point.



Hydraulic oil filling point.

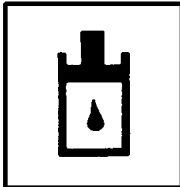

Remove starting handle.

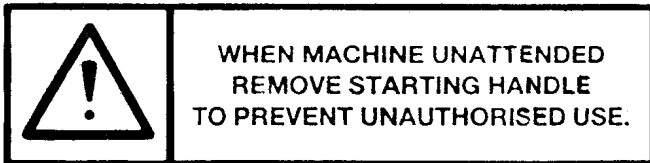

Attach lifting hooks to this eye.

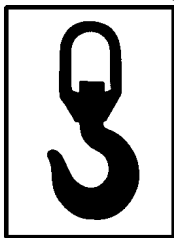

Beware of electrical hazards

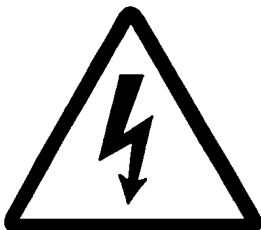

Wear ear protection. Wear eye protection.



The Battery Isolator is situated close to this decal.

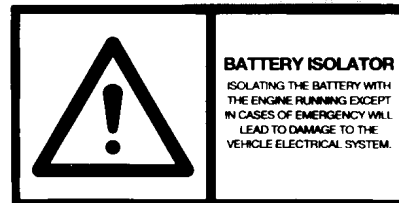

Read the operators Handbook, or Operators Handbook storage place.

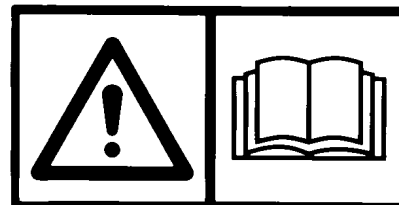

The battery negative terminal is connected to earth.

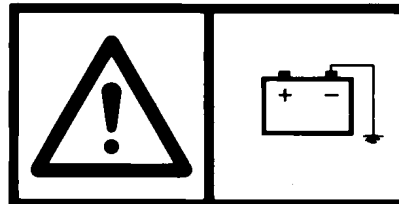

These surfaces may be hot.



CE (EC machines only)



Always reverse down gradients then loaded.

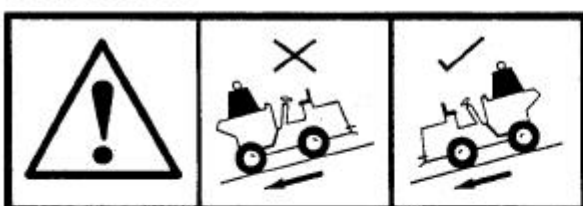

Forks and buckets are not to be used to push or lift the dumper.



ISO Skip Support, when used, is pinned around a tipping ram rod to prevent the ram from closing.



Keep hands away from moving parts.



The figures shown on the decals below indicate the maximum load for the skip onto which the decal is fastened.



Keep clear of crush zone.



ISO 8999 safety symbols used with Lister-Petter engines



Read the handbook



Stop control (on engine)

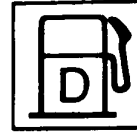

Diesel fuel fill



Engine oil fill



Engine oil level

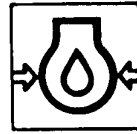

Engine oil pressure

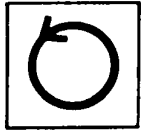

Anti-clockwise rotation

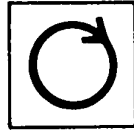

Clockwise rotation

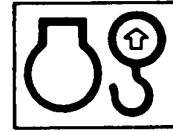

Lifting eye (engine only)

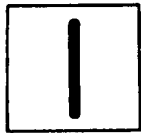

On

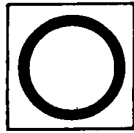

Off

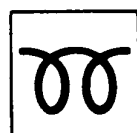

Pre-heat



Rotational speed control



Linear speed control



Tachometer



Elapsed hours



Battery Charging



Engine cranking



General hot surface warning



Electrical hazards

**CONTROLS AND SERVICE POINTS**

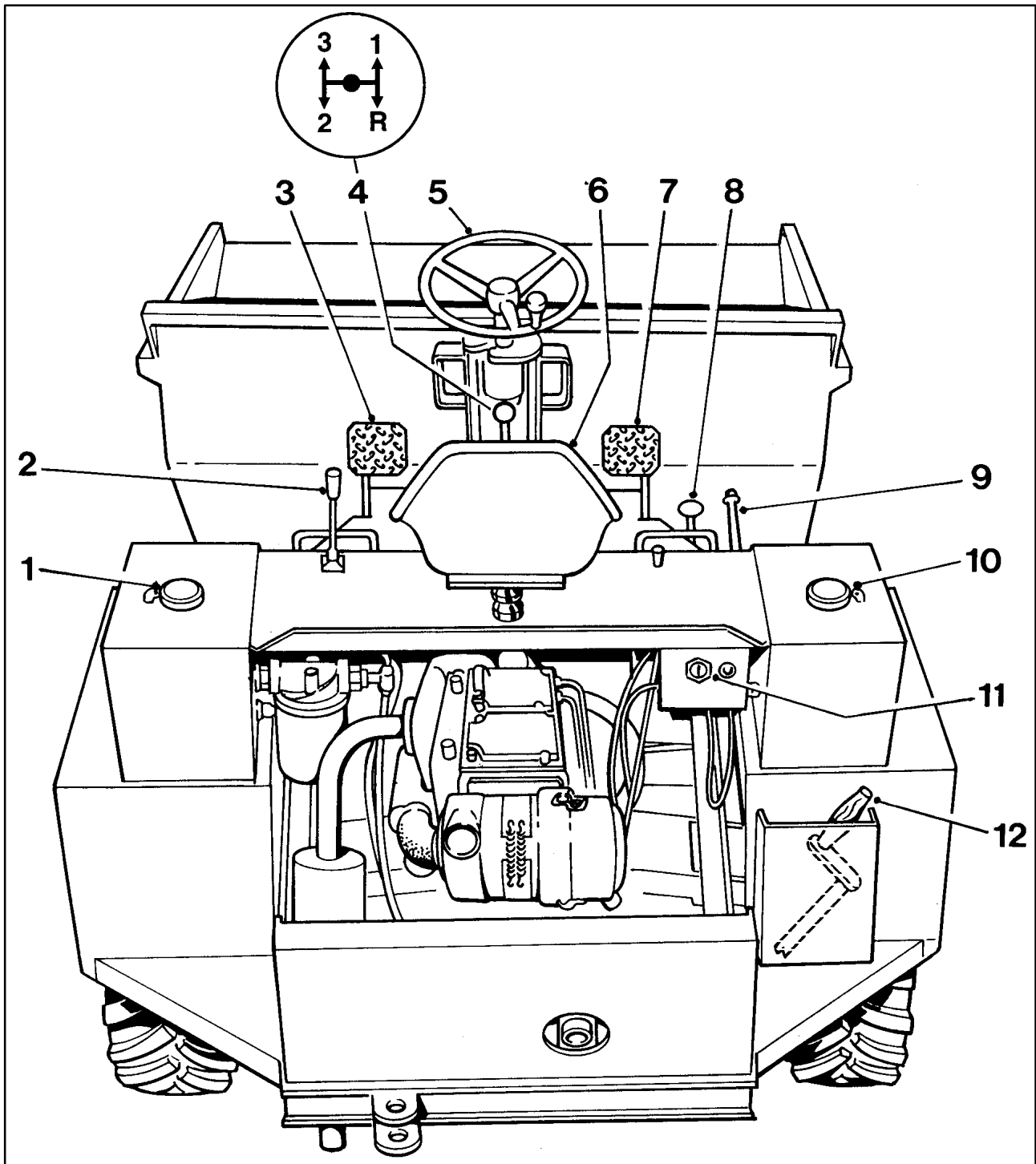

- 1 Hydraulic oil filler cap
- 2 Skip control, tip/return
- 3 Clutch
- 4 Gear lever
- 5 Steering wheel
- 6 Seat

- 7 Foot brake
- 8 Accelerator
- 9 Parking brake
- 10 Fuel filler cap
- 11 Key start switch (*where fitted*)
- 12 Engine starting handle (*stowage*)

## ROAD LIGHTS SWITCH PANEL

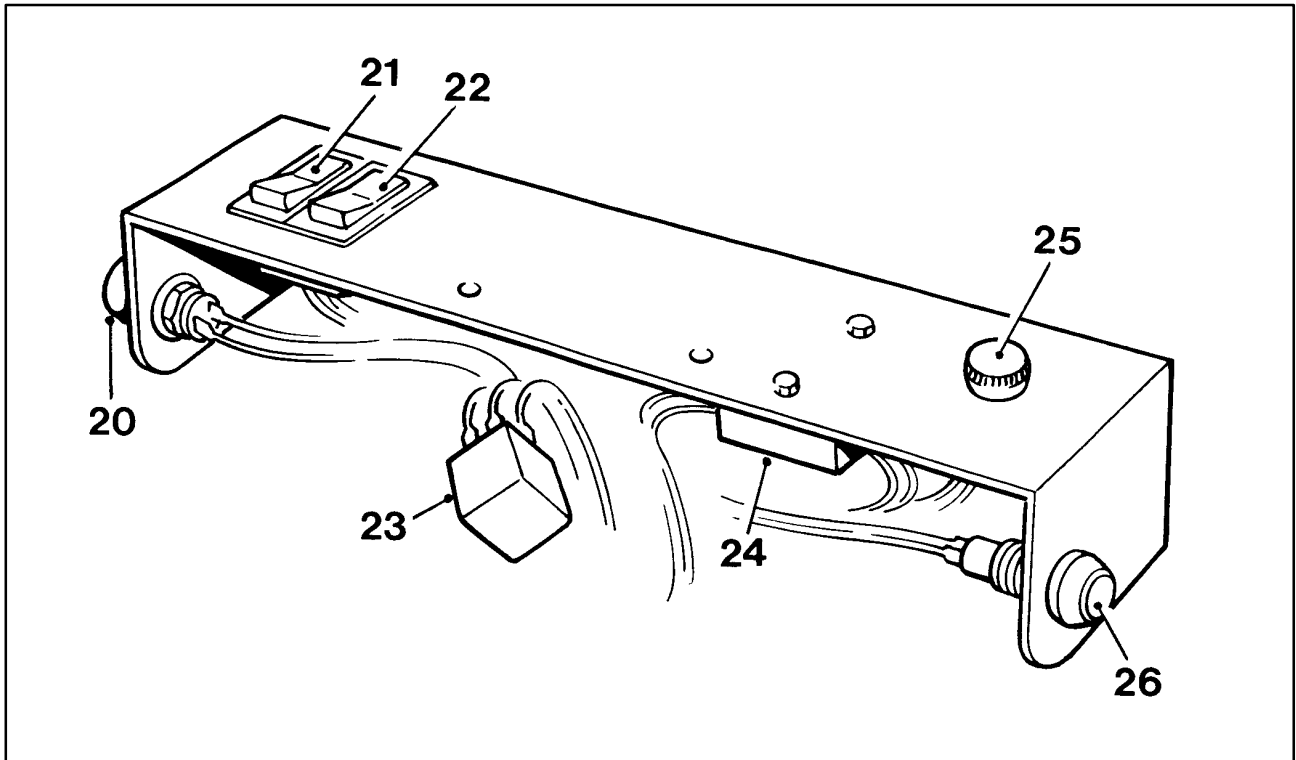

- 20 Horn
- 21 Switch: Side and head lights
- 22 Switch: Hazard warning lights
- 23 Flasher unit
- 24 Fuse box
- 25 Switch: Direction indicators
- 26 Warning light: Direction indicators

## DRIVING THE DUMPER

### Safety warnings

Read also the "*Safe Working*" Section before operating the dumper.

**WARNING** *ALWAYS wear correctly fitting protective clothing. Loose or baggy clothing can be extremely dangerous when operating or servicing machinery.*



*Only skilled personnel are permitted to work with this machine.*

*ALWAYS be aware of local and national regulations governing the use of this machine.*

### Starting the engine

**WARNING** *NEVER use ether type starting aids.*



*ALWAYS stop the engine if the battery charge warning light (where fitted) fails to cancel.*

*ALWAYS stop the engine if warning lights illuminate. Detect the fault before continuing.*

**DO NOT PROCEED IF A FAULT IS EVIDENT**

*NEVER attempt to start the dumper by pushing or towing.*

*NEVER operate controls unless you are seated on the machine, and ALWAYS remain in the driving seat whenever the engine is running.*

### Running-in a new engine

While a gradual 'running-in' of a new engine is not necessary, it is **EXTREMELY IMPORTANT** that the following instructions should be followed very closely during the first fifty hours of operation.

- 1 Avoid overloading the engine.
- 2 Use the lower gears when operating with heavy loads, and avoid continuous operation at constant engine speeds.
- 3 Check the instruments frequently, and keep the oil compartments and the hydraulic reservoirs filled to their recommended levels.
- 4 Do not operate the engine at high speeds without a load.
- 5 Do not allow the engine to run at idle speeds for long periods; this may cause bore glazing and an increase in oil consumption.

Operating in this way throughout the machine's life will prove beneficial to its overall performance and efficiency.

### Pre-start Checks

**WARNING** *NEVER commence work with the machine until the checks detailed in "Every 10 operating hours, or daily" have been carried out. (See Service Schedule).*



Check that all controls are clean and not slippery, and that they all function correctly.

Check that the areas around pivot points, rams and linkages are all free from mud, ice and debris.

Check that all grab handles, steps and platforms are clean and dry.

Check the machine for any obvious damage or faults.

Check that all decals can be clearly read.

### Petter PH2 engines (up to 1988)

#### To start Petter PH2 engines:

Ensure the parking brake is in the raised "ON" position.

Ensure gear lever is in the neutral position.

**WARNING** *If a starting handle is to be used, see that the shaft is greased. Make sure the starting handle can be freely withdrawn.*



On the engine, lift the overload stop **(A)** and move the fuel pump rack **(D)** in the direction of the arrow to the fully open position.

Operate the fuel pump priming lever **(C)** approximately six times. (This is unnecessary with a warm engine.)

Lift the decompression lever **(B)** to the vertical position. Crank the engine as fast as possible or use the starter motor. When the engine is turning at a good speed, knock down the lever **(B)**. The engine should now fire.

If the engine does not fire, lift the decompressor lever **(B)** and slowly turn the engine a few times before attempting to start again. Do not operate the starter motor for more than 20 seconds at a time.

**Note:** If it is necessary to bleed and prime the fuel system, consult the *PH2 Engine Operators Handbook*.

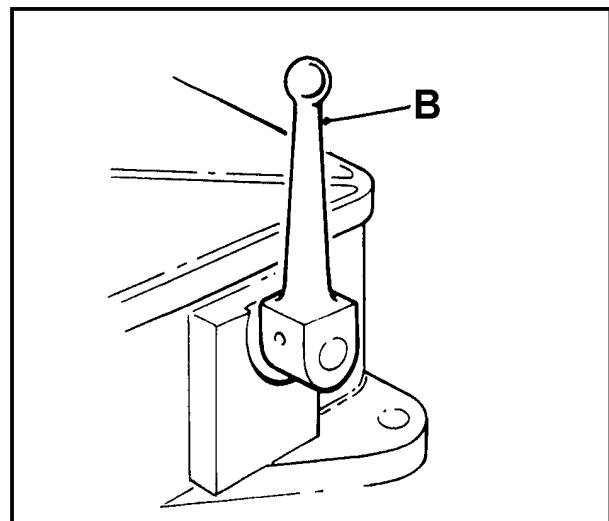
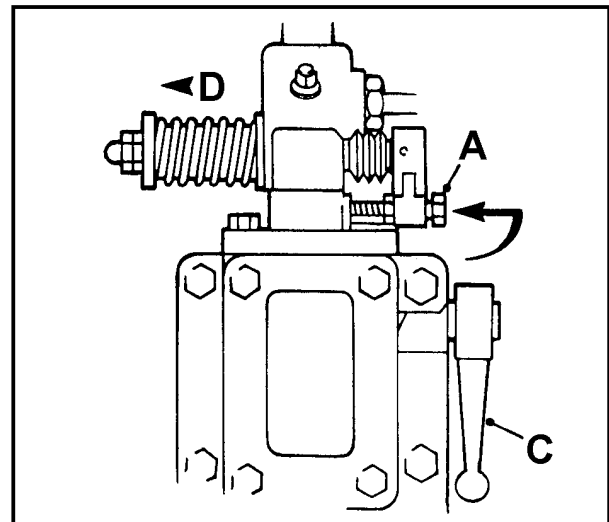

#### To stop PH2 engines:

**WARNING** *NEVER stop the engine by using the decompressor lever. This will lead to damaged valve seats and cylinder head joints.*



*DO NOT stop the engine by allowing the tank to run dry. This will make it necessary to bleed and prime the system.*

*DO NOT remove or alter the setting of the overload stop.*

It is advisable to run on light load for a few minutes before stopping.

Raise the priming lever **(C)** to the vertical position, or move and hold the fuel pump rack **(D)** away from the fly wheel until the engine stops.



## Lister ST3 engines (up to 1988)

### To hand start Lister ST3 engines:

Ensure the parking brake is in the raised "ON" position.

Ensure gear lever is in the neutral position.

Move the decompressor lever over towards the flywheel (F).

Pull the control lever outwards and allow it to rotate anticlockwise so that it abuts against the top stop and is in a vertical position (G).

**IMPORTANT:** Ensure that the starting handle is of the correct type and is fully servicable. Lightly oil the end of the starting shaft and the starting handle.

Check the arrow on the handle for correct rotation, then turn the handle in the opposite direction to that required to start engine. This is done in order to check that the clutch pin will disengage from the keyway, and does not bind on the starting shaft.

ENSURE THERE ARE NO BURRS ON THE SHAFT.

**IMPORTANT:** With the starting handle, turn the engine slowly from 3 to 20 turns according to the temperature and period of standing unused, in order to prime the combustion chamber and the lubricating oil system.

Turning the starting handle in the correct rotation, crank the engine really fast and when maximum cranking speed is reached move the decompressor lever away from the flywheel (H). Retain a firm grip on the starting handle and continue to crank until the engine fires. Remove the starting handle from the shaft.

**WARNING** It is dangerous to allow the handle to rotate on the running shaft.

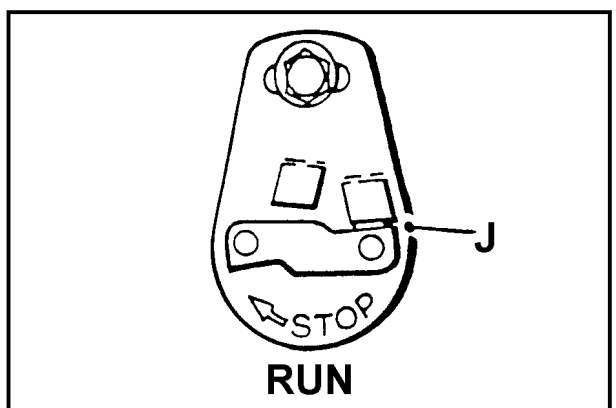
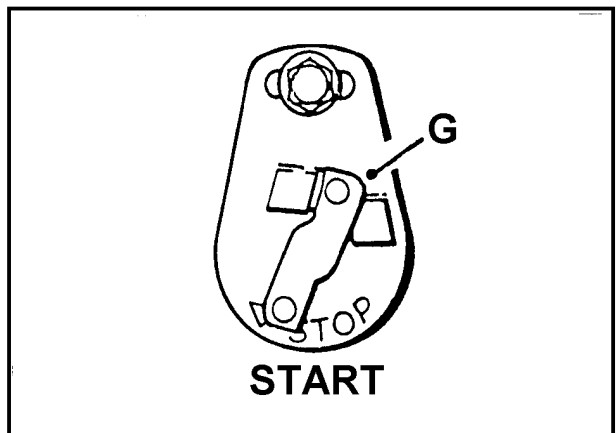
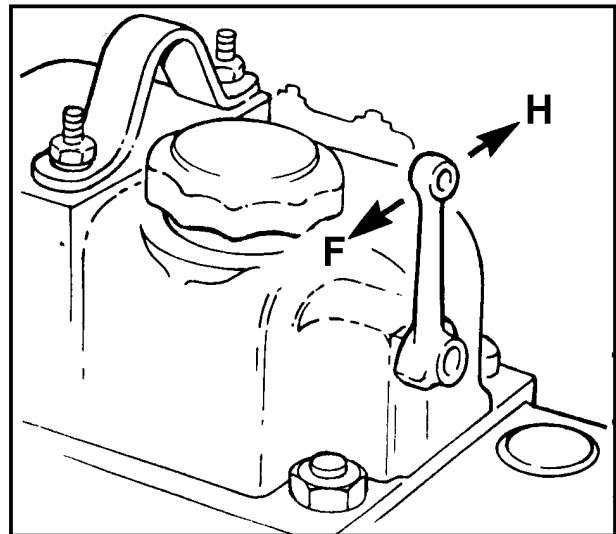

**IMPORTANT:** As soon as the engine reaches normal speed, turn the control lever clockwise to the horizontal position so that it abuts the horizontal stop (J).

### To key (Electric) start Lister ST3 engines:

Ensure the parking brake is in the raised "ON" position.

Ensure gear lever is in the neutral position.

Depress and hold down the accelerator.

Pull the control lever outwards and allow it to rotate anticlockwise so that it abuts against the top stop and is in a vertical position (**G**).

Turn the starter key and release immediately the engine fires. Do not motor the engine continuously for more than 20 seconds.

Release the accelerator pedal.

**IMPORTANT:** As soon as the engine reaches normal speed, turn the control lever clockwise to the horizontal position so that it abuts the horizontal stop (**J**).

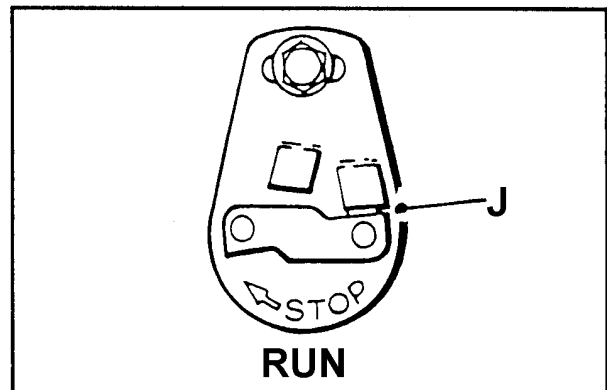
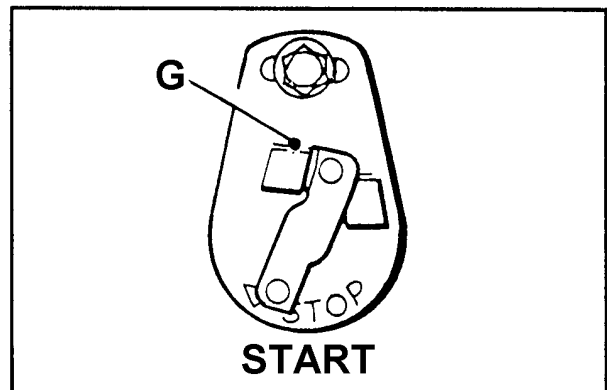

### Cold Starting Below -10deg.C (14deg.F)

A cup and plunger is fitted to the combustion air intake port on ST engines. Operate as follows:

Withdraw the plunger (**K**) and fill one third of the cup (**L**) with the same type of lubricating oil as used in the engine.

Replace the plunger and inject the oil just before starting the engine.

The device must not be used more than three times in succession. When hand starting, turn the engine 20 revolutions with the fuel on after injecting the oil, before attempting to start.

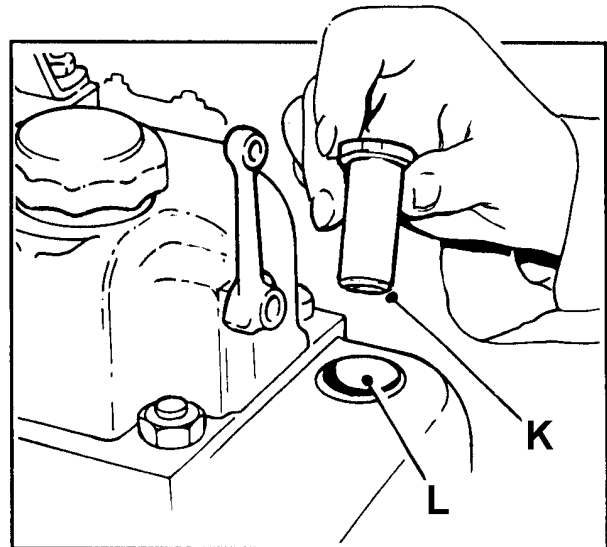

### To stop engine

Turn the control lever clockwise in the direction of the arrow (**M**) and hold it until the engine stops.

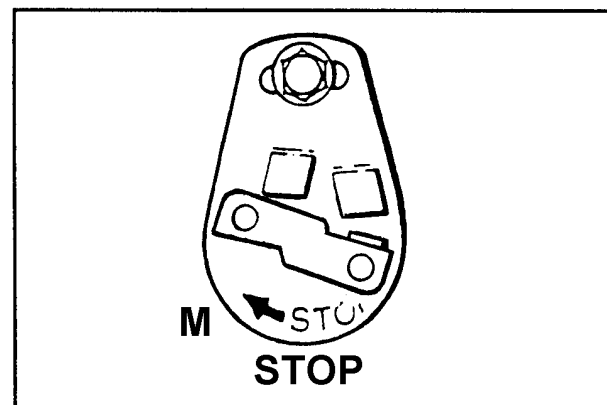

## TS/TR3 engines

### Description

- A Dipstick
- B Lubricating oil filler
- C Engine control
- D Decompressor levers
- F Cold start oil cup
- G Fuel lift pump

### Automatic Excess Fuel Device

The engine is fitted with an automatic excess fuel device which becomes operative, ready for the next start, when the engine is stopped.

If the engine stops other than by the operation of the engine control, the control (C) must be turned anti-clockwise to the 'STOP' position and released before the device can operate.

As the engine runs up to speed the excess fuel device will automatically reset to the normal running position.

### Cold Starting Below -10deg.C (14deg.F)

A cup and plunger is normally fitted to the combustion air intake port on TR and TS engines.

With the fuel turned on, turn the engine for up to 20 revolutions to prime the fuel and lubrication systems.

Withdraw the plunger (H) and fill one third of the cup (J) with the same type of lubricating oil as used in the engine.

Replace the plunger and inject the oil just before starting the engine.

**WARNING** *The device must not be used more than three times in succession during the same attempt to start the engine.*

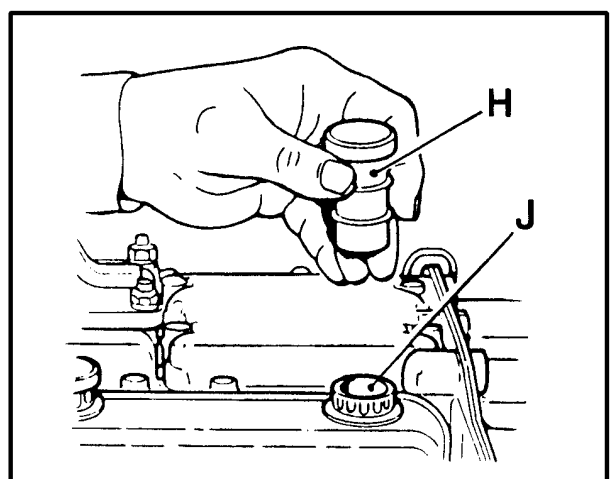
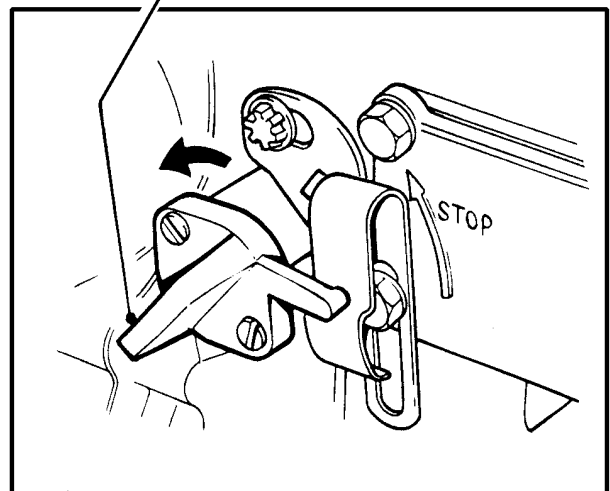
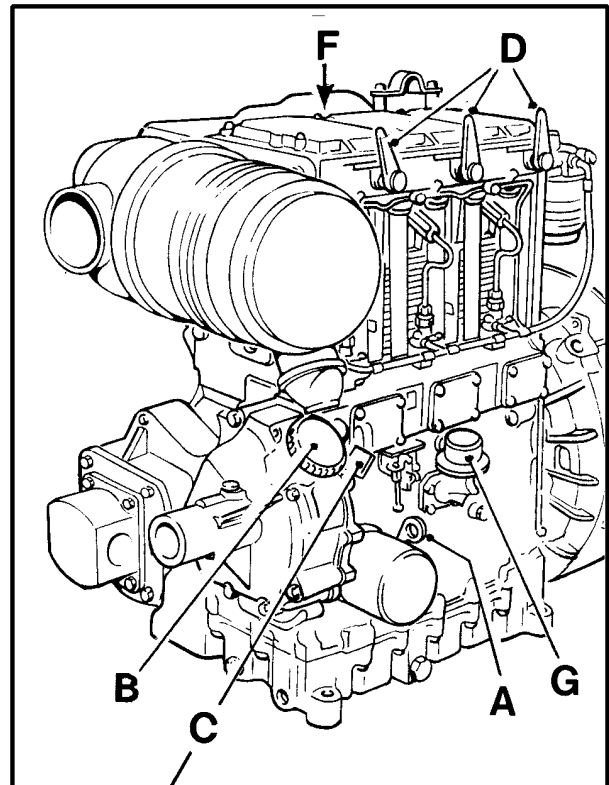

**Hand starting TS/TR3 engines**

Ensure the parking brake is in the raised "ON" position.

Ensure gear lever is in the neutral position.

**Always use the correct starting handle that has been designed for the engine.**

Ensure there are no burrs on the handle.

Before attempting to use the handle, clean and lightly oil that part of it which fits onto the engine.

**WARNING** *Do not attempt to use a handle if it is damaged in any way.*

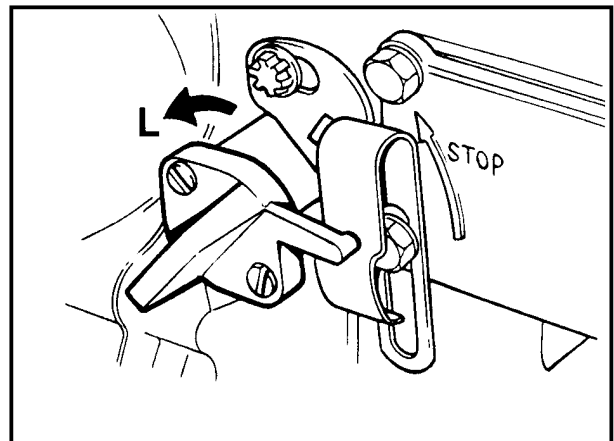

Turn the engine control lever anti-clockwise to the "STOP" position (**L**) and release it.

Move the decompressor lever towards the flywheel (**M**).

Insert the correct handle into the starting housing.

Turn the engine slowly for up to 20 turns to prime the combustion chamber and lubricating oil system.

Maintaining a firm grip on the starting handle, crank the engine really fast and when sufficient speed is obtained move the decompressor lever away from the flywheel (**N**) and continue to crank until the engine fires.

Retain a firm grip on the handle and remove it from the engine.

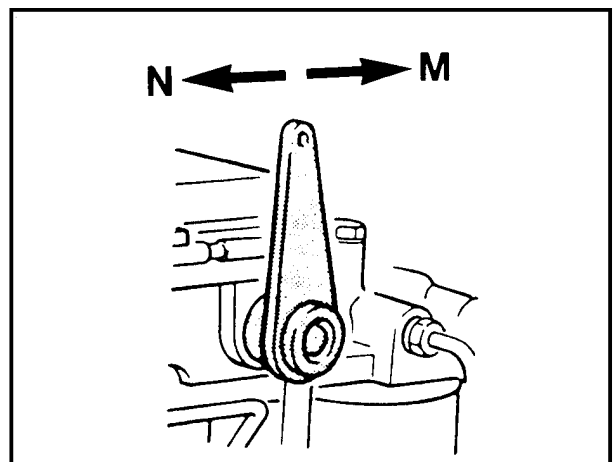

**Key Starting TS/TR3 engines**

Ensure the parking brake is in the raised "ON" position.

Ensure the gear lever is in the neutral position.

Fully depress and hold down both clutch and accelerator pedals.

Check that the decompressor lever, (if fitted) is away **(N)** from the flywheel.

Turn the engine control lever anti-clockwise to the "STOP" position **(L)** and release it.

Turn the start key clockwise to position **(1)**, the battery charging light **(P)** will illuminate.

Turn the key and hold at the "START" position **(2)** until the engine fires and then release it immediately.

If the engine fails to start within 20 seconds, release the key and attempt to restart after allowing sufficient time for all moving parts to stop.

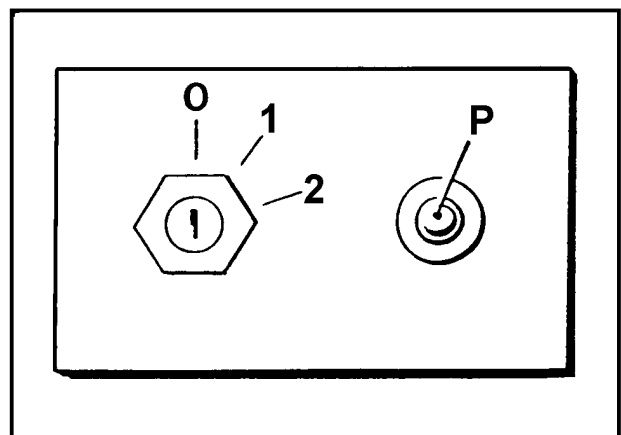
**Stopping the engine**

**WARNING** *Never stop the engine by operating the decompressor lever or valve damage may occur.*



**Key start engines:** *Turning the starter key to the "OFF" (0) position will not stop the engine.*

It is advisable to run on light load for a few minutes before stopping.

Turn the engine control anti-clockwise to the "STOP" position **(L)** and hold it there until the engine comes to rest.

**Key start engines:** After the engine has stopped, turn the starter key to the "OFF" **(0)** position.

## Gradients

**IMPORTANT:** *Read the notes in "Safe Working" and also remember the following:*

Slippery or loose surface conditions can adversely affect safe machine operation, particularly on gradients.

**ALWAYS** choose routes that avoid steep, slippery or loose gradients.

**NEVER** park the machine on a gradient.

**NEVER** attempt to turn on, or drive across, a gradient.

**ALWAYS** drive forwards up gradients when loaded.

**ALWAYS** reverse down gradients when loaded.

**NEVER** tow up or down gradients.

**NEVER** operate on a gradient which exceeds 25% (1 in 4), or across gradients which exceed 16% (1 in 6). This should be reduced where surfaces are wet or unstable.

**NEVER** operate high discharge or rotating skip options on gradients.

## Braking

The brake pedal operates hydraulic master cylinders that supply oil to brakes within the axles.

The handbrake operates a caliper that acts upon a disc mounted on the transmission.

## Engaging gear lever

When changing gear, always depress the clutch pedal before moving the gear lever from one gear to another.

## Stopping the dumper

**IMPORTANT:** *Never make unnecessary 'crash' stops when travelling at speed, especially in forward direction.*

Release accelerator and brake to a halt progressively.

Select neutral gear.

Apply parking brake when stationary.

Stop the engine. Turn the starter key to the 'OFF' position, and remove the key.

## Leaving the dumper

Ensure the machine is parked on firm, level ground. Do not park on a gradient.

Check that the parking brake is applied.

Ensure that the skip is fully lowered.

With the engine stopped, operate the skip hydraulic control lever fully in each direction several times to 'dump' hydraulic pressure from the system.

Remove starter key (where fitted) from switch.

*Electric start dumpers:* If unattended for some time, remove earth cable from battery, or activate the Battery Isolator, (where fitted).

## **Skip operation**

### **Loading**

Never remain on the dumper when using excavators or loaders to load the skip. Stop the engine, apply the parking brake, dismount, and stand well clear.

Ensure that the load is evenly distributed in the skip. Never carry loads in such a manner as to affect the forward vision.

Never exceed the rated payload. The weights of all loads above skip water level must be checked.

### **Tipping**

Only discharge on level ground.

It is recommended that only free flowing materials be tipped. *Take extra care when tipping non free running loads.*

### **Skip control lever**

The control lever has three positions; they are, Tip (or Dump), Hold and Return.

*To tip the skip:*

Move the lever to DUMP

*To return the skip:*

Move the lever to RETURN.

If the lever is released when in the DUMP or RETURN position, it will automatically return to the central HOLD position and movement of the skip will stop. In this way, the speed at which the skip is tipped can be finely controlled.

### **Rotating skips (where fitted)**

After releasing the turntable locking catch, rotate the skip manually, then tip by using the hydraulic control lever.

When returned to the carrying position, ensure that the turntable catch is locked.

### **Towing with the dumper**

Dumpers are not designed as towing vehicles, however, trailers may be towed providing that:

- 1 The combined weight of the trailer and its load does not exceed the specified maximum dumper payload.  
(see "*specifications*")
- 2 Trailers may be towed in first gear on level dry ground, provided a purpose made towing pin is used.
- 3 The dumper skip must be loaded with half the rated payload to ensure tyre adhesion when braking.

Never tow loads up, down or across gradients.

### **Towing the dumper**

The dumper should only be towed if recovery is needed of a broken-down unit, or to free a "bogged down" machine.

Always ensure that ropes, chains, etc. used to tow the dumper have sufficient safe working load capability.

When towing the dumper, always ensure that the speed is kept to an absolute minimum.

Always tow the dumper with the gear lever in neutral.

Never attempt to start the dumper by pushing or towing.



**SAFE WORKING**

**WARNING** *Read the safety notes in "Safe Working", Section 1 of this book.*



*Also note the following:*

**Safe handling of oils, filters and filter elements**

**WARNING** *Do not allow oils to come into regular contact with skin. This can lead to serious skin diseases. Medical evidence suggests they may include skin cancer.*



*Always wear protective gloves when handling oils for topping up, draining, or refilling.*

*Dispose of waste oil into waste oil storage tanks. If storage tanks are not available, consult your Distributor or local authority for addresses of local designated disposal points.*

*It is illegal to dispose of waste oil into drains or water courses or to bury it.*

*The materials used in the manufacture and treatment of some filters and elements may cause irritation or discomfort if they come into contact with the eyes or mouth and they may give off toxic gases if they are burnt.*

*After handling any filters or oils the user's hands should be thoroughly washed, particularly before eating.*

*Used filter elements contain some of the filtered oil and should be handled and disposed of with care.*

## SERVICE SCHEDULE

**IMPORTANT:** The engine will require additional services or adjustments in addition to those listed below (See *the appropriate Engine Operator's handbook or Workshop Manual*).

**WARNING:** Warning lights and indicators *REQUIRE IMMEDIATE ACTION.*

SERVICE OPERATION	REFERENCE	PAGE
-------------------	-----------	------

### **Every 10 operating hours, or daily**

*Carry out any procedures described above, plus the following.*

Engine oil level	Engine	3.4
Fuel tank level	Engine	3.6
Air cleaner	Engine	3.9
Wheel nut tightness	Wheels & tyres	3.21
Axle oil seals	Axles	3.22
Hydraulic oil level & hose condition	Hydraulic system	3.16

### **Every 50 operating hours, or weekly**

*Carry out the procedures for the previous service interval, plus the following.*

Axle nuts	Axles	3.22
Axle oil levels	Axles	3.22
Tyre pressures & condition	Wheels & tyres	3.21
Fuel tank filler strainer	Engine	3.6
Battery electrolyte level	Battery	3.13
Grease nipples	Greasing	3.19
Gearbox / Transfer box oil levels	Gearbox / Transfer box	3.10
Parking brake Check function of the parking brake and adjust if necessary.		
Propeller shaft Tighten securing nuts. (See also Propeller Shaft Installation on page 3.12)		
Brake pedal travel Check the action of the brake pedal; it should have a short travel and firm action. If travel is excessive, or the action spongy, have the brakes serviced by your distributor.		

### **First 100 operating hours**

*Carry out the procedures for the previous service intervals, plus the following.*

Hydraulic oil filter	Hydraulic system	3.17
----------------------	------------------	------

# SERVICE

3.3

## SERVICE OPERATION

## REFERENCE

## PAGE

### **Every 125 operating hours**

Carry out the procedures for the previous service intervals, plus the following.

Air cleaner element	Engine	3.9
---------------------	--------	-----

### **Every 250 operating hours**

Carry out the procedures for the previous service intervals, plus the following.

Engine oil and filter	Engine	3.5
Fuel filter	Engine	3.7

### **Every 300 operating hours**

Carry out the procedures for the previous service intervals, plus the following.

Hydraulic oil filter	Hydraulic system	3.17
----------------------	------------------	------

### **Every 500 operating hours**

Carry out the procedures for the previous service intervals, plus the following

Air cleaner element	Engine	3.9
Fuel filter	Engine	3.7
Frame assembly bolts	Check all structural nuts & bolts for tightness	

### **Every 1000 operating hours**

Carry out the procedures for the previous service intervals, plus the following.

Hydraulic oil & filter	Hydraulic system	3.17
Gearbox / transfer box oil change	Gearbox / Transfer box	3.10
Axle oil change	Axles	3.22

### **Every 2000 operating hours, or two years**

Carry out the procedures for the previous service intervals, plus the following.

Brake system overhaul	Braking system	3.20
-----------------------	----------------	------

### **Extra services**

#### Dirty working conditions

Increase the frequency of all services during extremes of dirt, heat and cold, especially those relating to clean air, cooling efficiency, lubrication and machine cleanliness.

#### Laying-up protection

When a machine is to remain idle, remove the battery to the workshop. Seal all openings: air intake, exhaust breathers. Grease bright parts and protect rubber components from direct sunlight. Fill the fuel tank, check the tyre pressures and exhaust any pressure from the hydraulic system.

**ENGINE****Engines fitted in dumpers**

*Up to 1985: Lister ST3 and Petter PH2*

*1985 to 1989: Lister-Petter PH2*

*1985 to date: Lister-Petter TS3*

**IMPORTANT**

To service the following engines,

**Lister ST3**

**Petter PH2**

Please refer to relevant Engine Operator's Handbook or Workshop Manual.

**Lister-Petter TS3**

This engine will require other services and adjustments in addition to those quoted in this handbook. Please refer to the relevant engine Operator's Handbook or Workshop Manual.

**Engine lubrication oil**

For engine oil grades and oil change periods when operating in temperatures above 30 deg.C, see "Engine Handbook".

**WARNING**

*Lubrication oil cleanliness is vital for the successful operation of your engine. The oil should be stored under the cleanest possible conditions. When changing or topping-up oil, use only clean receptacles.*

*Always wear protective gloves when handling oils for topping up, draining, or refilling.*

*Oils and fuels can cause skin irritation. Wear suitable protective clothing to prevent skin contact.*

*After handling oils the users hands should be thoroughly washed, particularly before eating.*

**Every 10 operating hours, or daily**

**Engine oil level**

Check lubrication oil level as follows:

Stop the engine and allow the oil to settle.

Remove and clean the dipstick **(B)**, then check that the oil is at the full mark. If the level is low, top up through the filler **(C)** to the full mark with clean oil of the correct grade. **DO NOT OVERFILL.**

For correct grade of engine oil, see "Specifications".

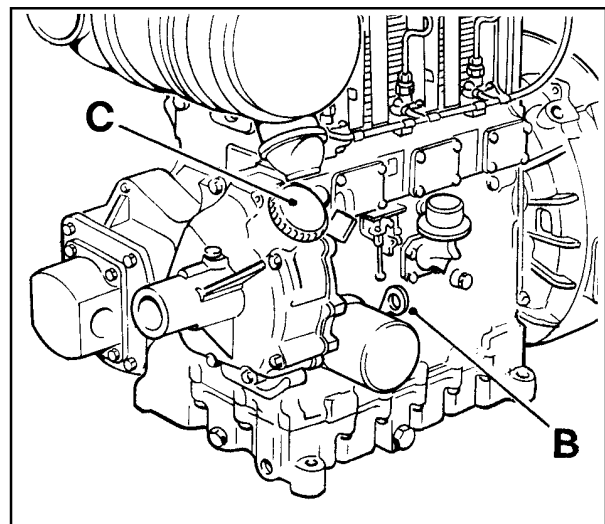

**Every 250 hours****Engine oil**

Drain and refill the oil sump as follows:

If possible run the engine immediately before draining the oil.

Place a suitable container under the drain plug. Remove the drain plug (**D**) and drain oil.

Clean and coat the threads of the drain plug with an appropriate sealant.

Replace the drain plug (**D**) taking care not to overtighten it.

Fill the sump through the oil filler (**C**) to the top mark on the dipstick (**B**).

Start the engine, run it for a few minutes and check the drain plug does not leak.

Stop the engine, allow the oil to settle and check the level on the dipstick.

Add more oil if necessary.

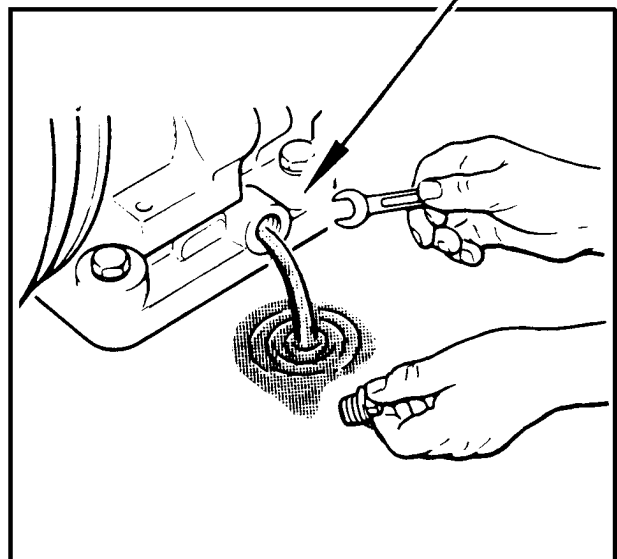
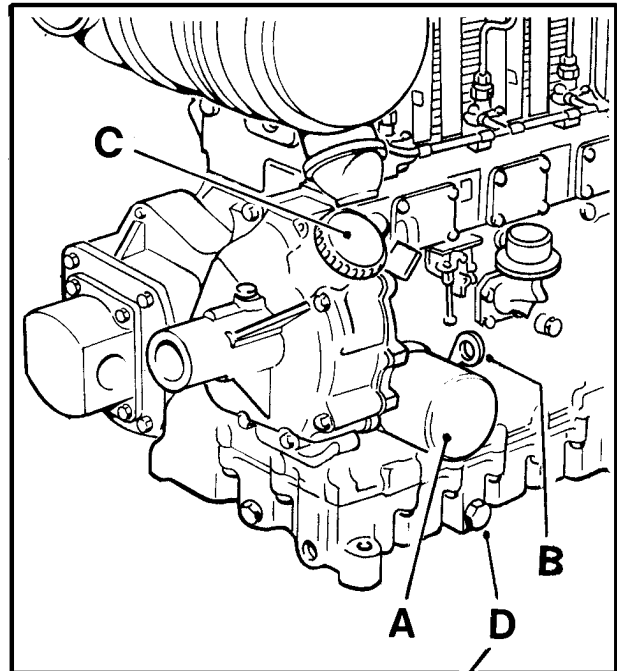
**Every 250 hours****Oil filter**

Change oil filter element as follows:

Using a suitable strap wrench, unscrew and remove the old filter (**A**).

**Do not attempt to clean the old filter! Dispose of it safely.**

Thoroughly clean the crankcase filter housing face.

Apply a small amount of clean engine oil to the filter sealing joint.

**Do not use a strap wrench to fit the new element.**

Screw on the new filter by hand, until the sealing joint is just touching the crankcase and then tighten a further half turn.

Run the engine and check for any oil leaks.

Stop the engine, allow the oil to settle and check the level on the dipstick (**B**).

Add more oil if necessary.

Do not check oil level until the engine has been stopped for 2 minutes.

Remove and clean dipstick then check that the oil is at the full mark. If level is low, top up through the filler to the full mark with clean oil of the correct grade. **DO NOT OVERFILL.**

*For correct grade of engine oil, see "Specifications".*

**Every 10 operating hours, or daily**

## Fuel tank

Fill the fuel tank at the end of each day to reduce overnight condensation within the tank.

### WARNING



*Never mix gasoline or any other fuel mixes with diesel fuel because of increased fire or explosion risks.*

*Never remove the filler cap, or refuel, with the engine running.*

*Never smoke when refilling the tank.*

To fill the tank:

Stop the engine.

Clean the area around the filler cap.  
Remove the cap.

Fill the tank. *Do not fill the tank to capacity. Allow room for expansion, and wipe up spilt fuel immediately, otherwise paintwork will be damaged.*

Replace cap.

## Fuel filter (Cartridge Agglomerator)

Check that there is no accumulation of water in the base of the agglomerator by unscrewing the drain tap **(L)** sufficiently to allow any water to empty, then retighten the tap.

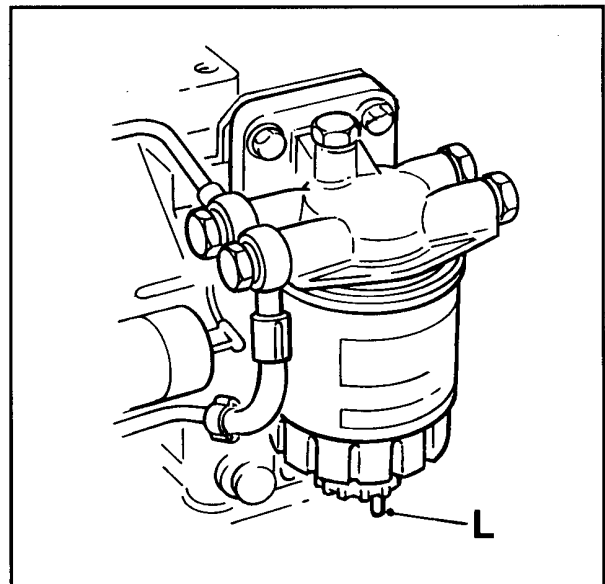

**Every 50 hours**

## Fuel tank strainer

When filling the fuel tank, check that the strainer within the filler neck is clear of sediment.

*Every 250 hours*

**Fuel filter element/cartridge**

Change the fuel filter element/cartridge if the fuel being used is not perfectly clean (see below).

*Every 500 hours*

**Filter Element, or Cartridge Agglomerator**

**Change Fuel Filter Element as follows:**

Remove the retaining bolt (E).

Remove the element (F) and joints (G).

Fit new element and new joints.

Replace and tighten retaining bolt (E).

Prime the system.

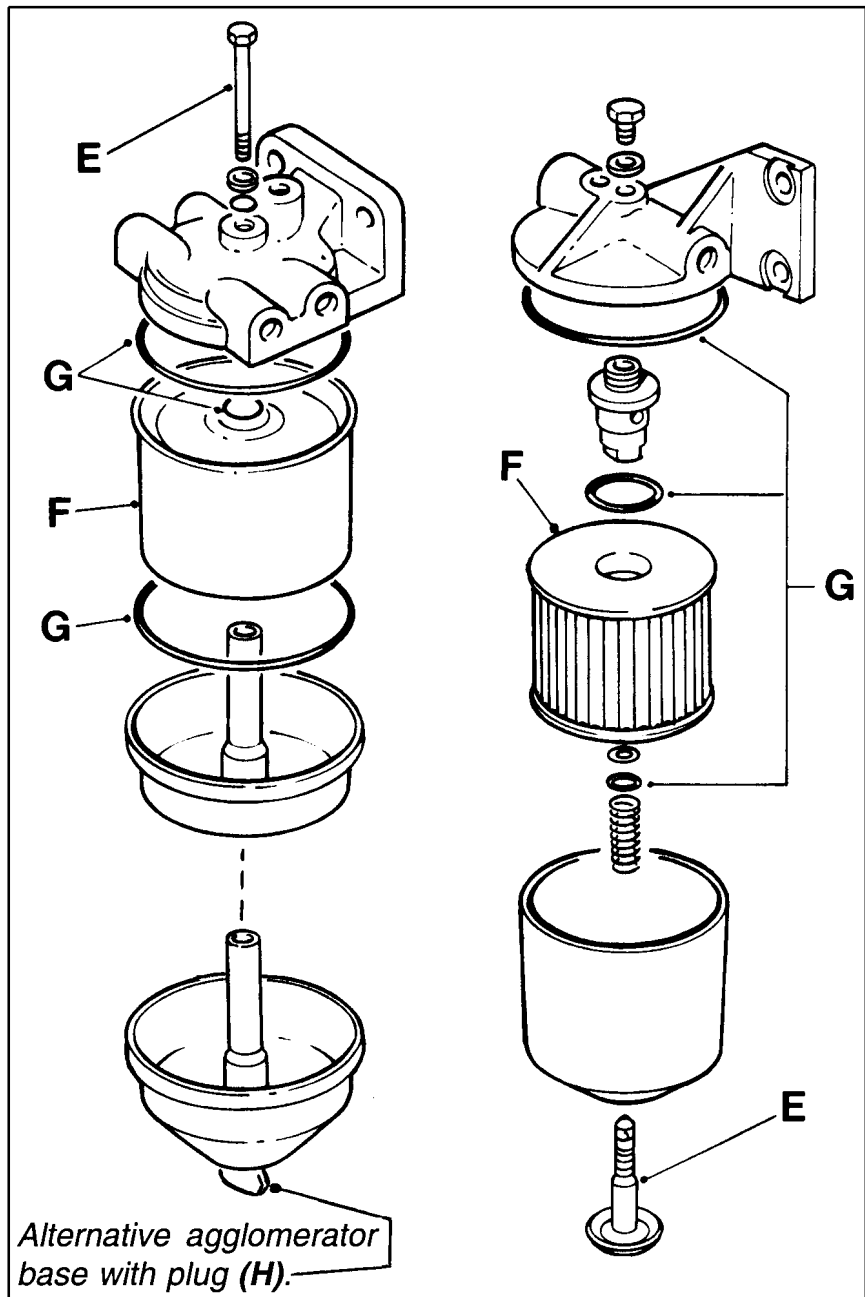

*Alternative agglomerator base with plug (H).*

**Change Cartridge Agglomerator as follows:**

The cartridge agglomerator should be renewed more frequently than every 500 hours, if for any reason the fuel is known to be dirty.

To change the cartridge agglomerator:

Use a suitable strap wrench to unscrew the cartridge (M) from the head (N).

**DO NOT USE A STRAP WRENCH TO FIT THE NEW CARTRIDGE!** Screw a new cartridge onto the head and hand tighten only.

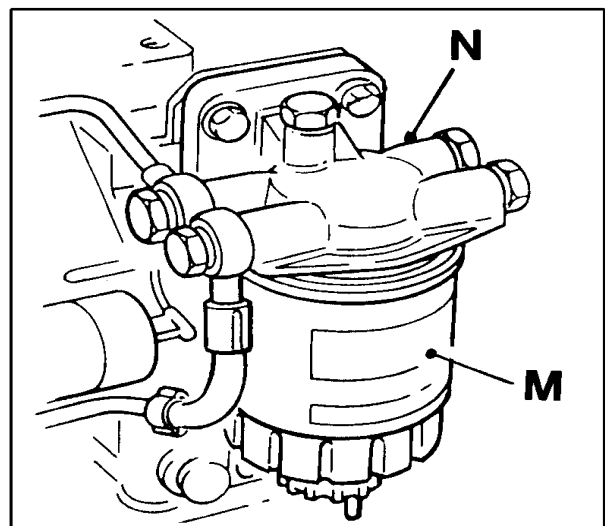

### Priming the fuel system

Prime the system as follows:

Fill the fuel tank.

Move the engine control lever to the RUN position.

Release the bleed screw **(O)** on the filter head, then operate the priming lever **(P)** on the lift pump until a full air free flow is obtained.

Retighten bleed screw **(O)**.

Vent each injector pump in turn by releasing screw **(R)**, then operate the priming lever **(P)** on the lift pump until a full air free flow is obtained.

Retighten bleed screw **(R)**, then repeat for the other injector pump.

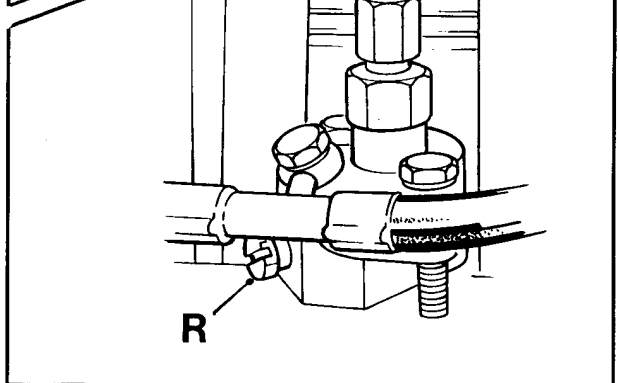
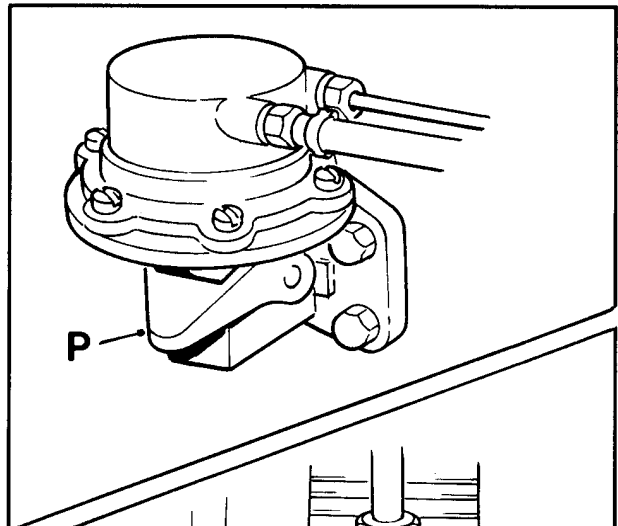
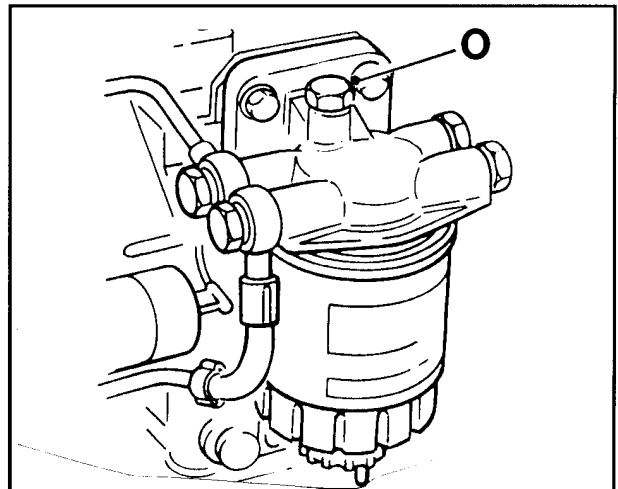



*Every 10 operating hours, or daily*

**Air cleaner: clean/replace**

Clean or replace the outer element **(A)** under very dusty conditions as described below:

*Every 125 operating hours*

**Air cleaner: clean/replace**

Clean or replace the outer element **(A)** under moderately dusty conditions as described below:

Access the elements by unhooking the retaining clips and removing the cover.

Remove the outer element **(A)** and clean or replace it as necessary.

Replace the element.

Replace the cover with the inlet facing downwards.

**WARNING** *No attempt must be made to clean the inner element **(B)**.*



*After the outer element **(A)** has been cleaned three times the inner element **(B)** must be replaced.*

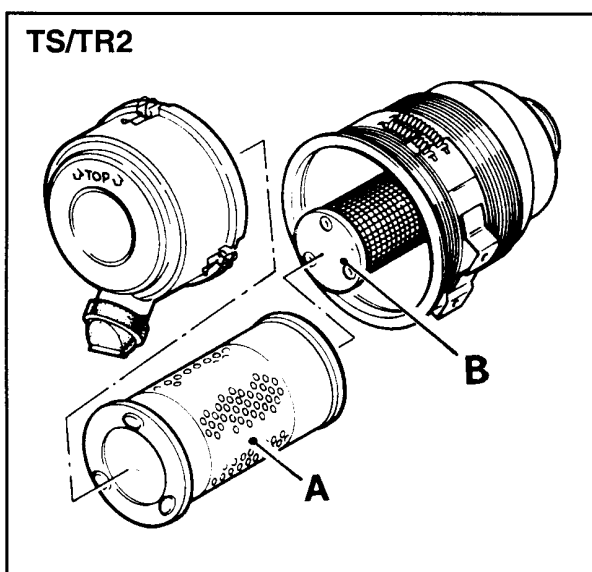

## GEARBOX

### Safe handling of oils

**WARNING** *Do not allow oils to come into regular contact with skin. This can lead to serious skin diseases. Medical evidence suggests they may include skin cancer.*



*Always wear protective gloves when handling oils for topping up, draining, or refilling.*

*Dispose of waste oil into waste oil storage tanks. If storage tanks are not available, consult your Distributor or local authority for addresses of local designated disposal points.*

*It is illegal to dispose of waste oil into drains or water courses or to bury it.*

### Every 50 operating hours, or weekly

#### Check gearbox oil level

Check the gearbox oil level when the machine has stood for 2 minutes.

Clean the area around the dipstick/filler **(V)** before removing.

Remove the dipstick and check the oil level. Top-up between the two marks **(W)**. *It is most important not to overfill.*

For the correct type and grade of oil, see "Specifications".

### Every 1000 operating hours

#### Change gearbox oil

Clean the areas surrounding the dipstick **(V)** and drain plugs **(X)**.

Place a suitable container beneath the drain plug.

**CAUTION:** Before removing the drain plug, be sure to stand to one side to avoid the oil that will spill from the hole.

Remove the drain plug **(X)** and drain the gearbox. *(Do not lose its sealing washer.)*

Replace drain plug with its sealing washer.

Remove the dipstick **(V)** from the filler hole.

Fill with oil. Check that the final level is between the two marks on the dipstick. *It is most important not to overfill.*

For the correct type and grade of oil, see "Specifications".

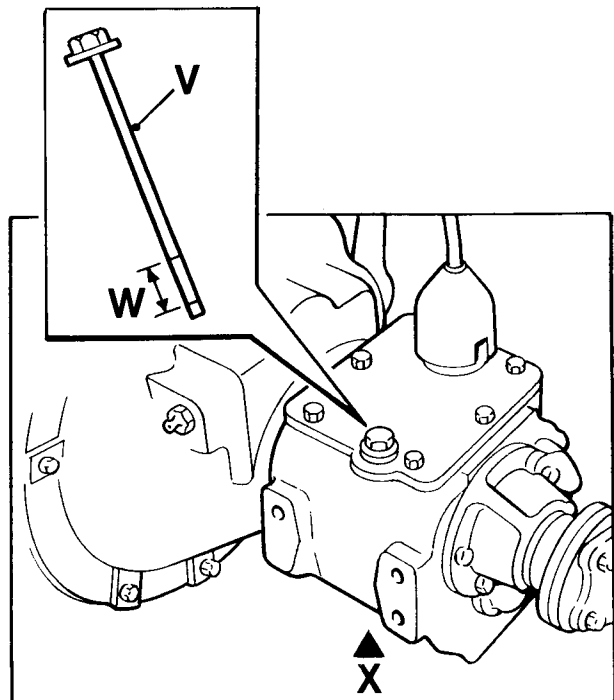

**TRANSFER BOX**

*Every 50 operating hours, or weekly*

**Check transfer gearbox oil level**

Clean the area surrounding the filler/level plug (**Y**) before removing it.

Check and top-up through the filler/level plug hole (**Y**) until the oil is level with the bottom of that hole.

For the correct type and grade of oil, see "*Specifications*".

*Every 1000 operating hours*

**Change transfer gearbox oil**

Place a suitable container beneath the drain plug (**Z**).

Drain oil by removing the plug (**Z**). (*Do not lose its sealing washer.*)

Replace drain plug with its sealing washer.

Fill with oil at filler/level plug (**Y**) to the correct level. Replace filler/level plug with its sealing washer.

For the correct type and grade of oil, see "*Specifications*".

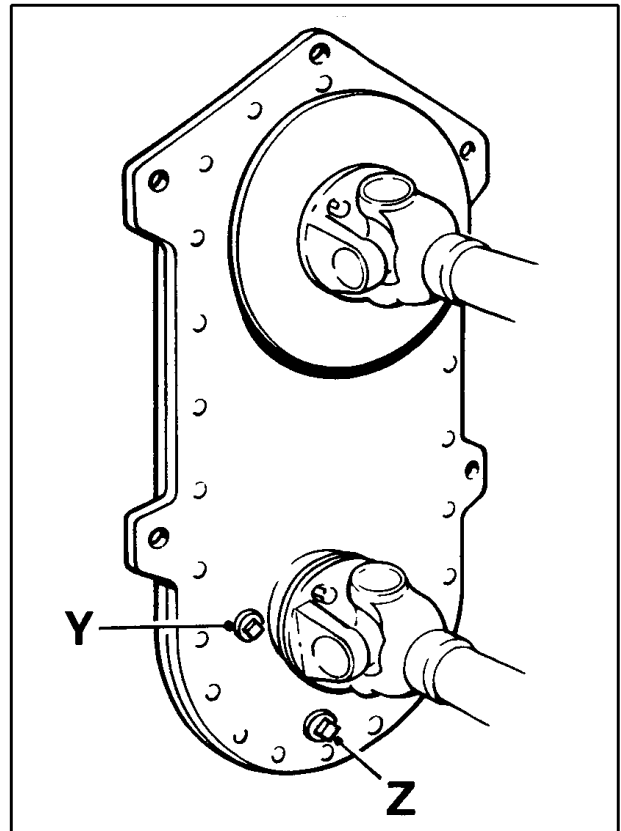

## PROPELLER SHAFT

### Propeller shaft Installation

ALWAYS ensure that the larger yoke (X) of the propeller shaft is fitted to the transfer box, NOT the smaller yoke (Y).

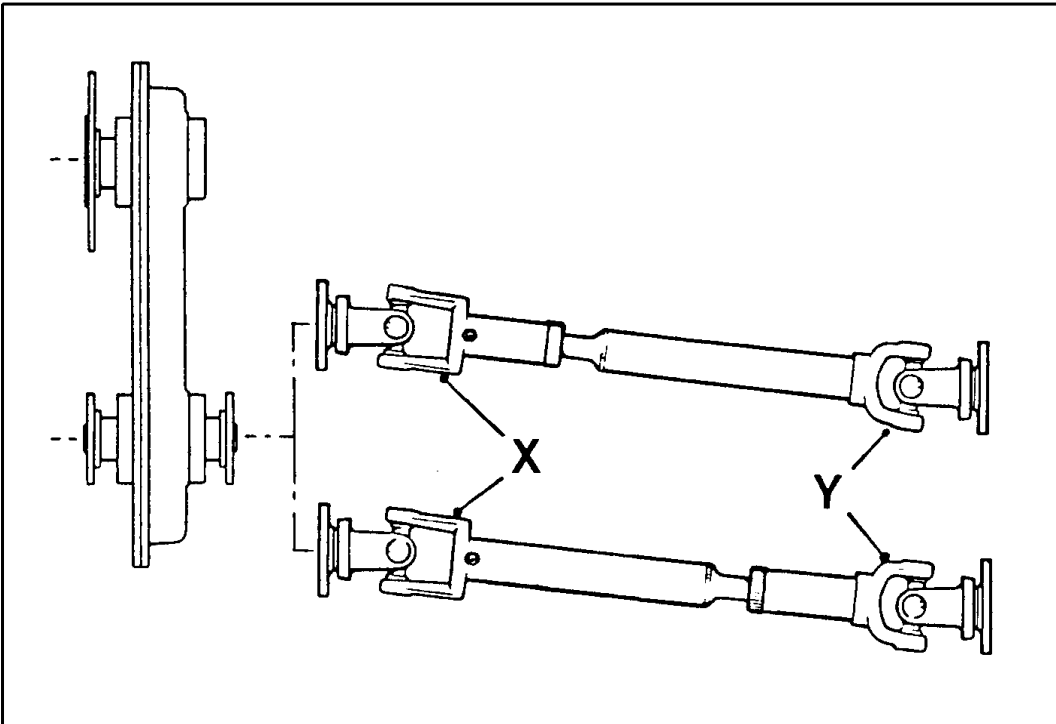

## BATTERY

## Safe handling of batteries

## WARNING



*WARNING The battery contains a sulphuric acid electrolyte which can cause severe burns and produce explosive gases.*

*Wear protective clothing, gloves and goggles when servicing the battery.*

*Avoid contact with the skin, eyes or clothing. If spilled onto the skin, flush immediately with cold water. If splashed into the eyes, flush immediately with cold water for 15 minutes and get prompt medical attention.*

*Do not take internally. If accidentally swallowed, call a doctor immediately.*

*Do not use a naked flame or smoke near the battery. Do not produce sparks with cable clamps when charging the battery or starting the engine with a slave battery.*

*ALWAYS disconnect battery leads, or activate battery isolator where fitted, before carrying out any maintenance to the electrical system.*

*ALWAYS dispose of unserviceable batteries safely. Comply with local byelaws and national regulations on the disposal of hazardous waste. Consult your local authority for addresses of local designated disposal points.*

## Every 50 hours

## Check battery electrolyte level

The battery is situated beneath a cover on the left-hand side of the dumper.

Ensure that the electrical connections are clean and tight, and coat the terminals with petroleum jelly to protect them from corrosion.

Remove battery filler plugs and check that the electrolyte level is between 6 - 9 mm (0.25 - 0.37 in) above the tops of the separators.

If necessary, top-up with distilled water.

Replace battery filler plugs and tighten securely.

## Battery removal

## WARNING



*If the battery is to be removed from the machine, ensure the following procedure is used.*

Switch the engine off.

Remove the starter key from the machine.

Ensure all electrical circuits are switched off. Activate the battery isolator, where fitted.

Remove the battery cover and clamp.

Disconnect the earth (-) lead from the battery before removing the positive (+) lead.

Lift the battery from the machine.

## WARNING



*When installing the battery, the positive (+) lead MUST be connected first.*

## HYDRAULIC SYSTEM

### Hydraulic System Safety

(see also "Safe Working" section)

**WARNING**



*Do not allow oils to come into regular contact with skin. This can lead to serious skin diseases. Medical evidence suggests they may include skin cancer.*

*Always wear protective gloves when handling oils for topping up, draining, or refilling.*

*Always practise the greatest cleanliness when servicing hydraulic components.*

*Always clean the areas surrounding filler points, filters etc., before and after servicing.*

*Dispose of waste oil into waste oil storage tanks. If storage tanks are not available, consult your Distributor or local authority for addresses of local designated disposal points.*

*It is illegal to dispose of waste oil into drains or water courses or to bury it.*

### Description of hydraulic system

The hydraulic system provides power for skip tipping.

The main components consist of:

**Tank:** The tank is filled through a filler/strainer which incorporates an oil level indicator. The filler cap is fitted with a breather. In the bottom of the tank is a suction strainer.

**Pump:** The pump is driven directly from the engine.

**Filter:** The filter is situated in the return to tank hose from the control valve.

**Tipping control valve:** The control valve receives oil from the pump and delivers it to the skip tipping rams. The rate of oil flow to the rams is proportional to the distance that the control valve lever is moved.

If the control lever is held either fully forward or backward after the rams have reached their full stroke, a relief valve opens, allowing the oil to return to the tank.

### Dumping hydraulic pressure

**WARNING**



*Always dump all hydraulic pressure from the system before servicing any hydraulic component.*

### To dump pressure:

**Stop the engine.**

**Move the skip control lever several times in each direction.**

Hydraulic system

Standard skips are fitted with two rams

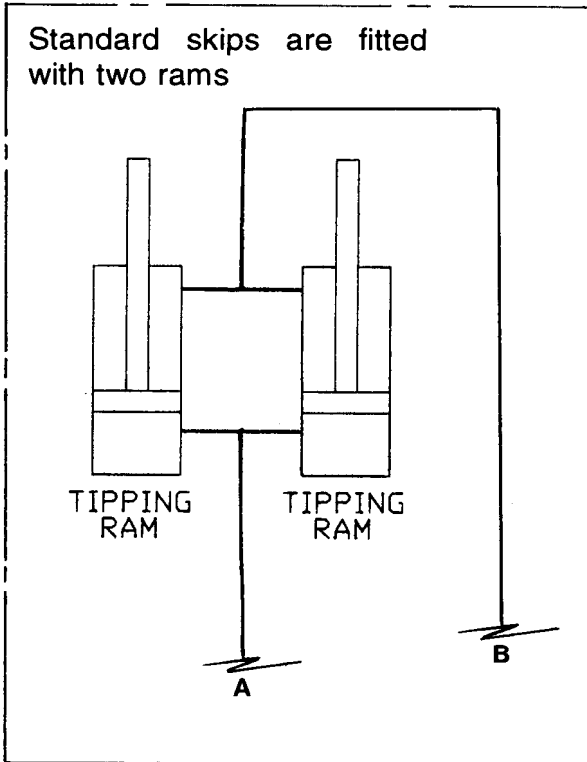

High discharge and rotating skips are fitted with one ram

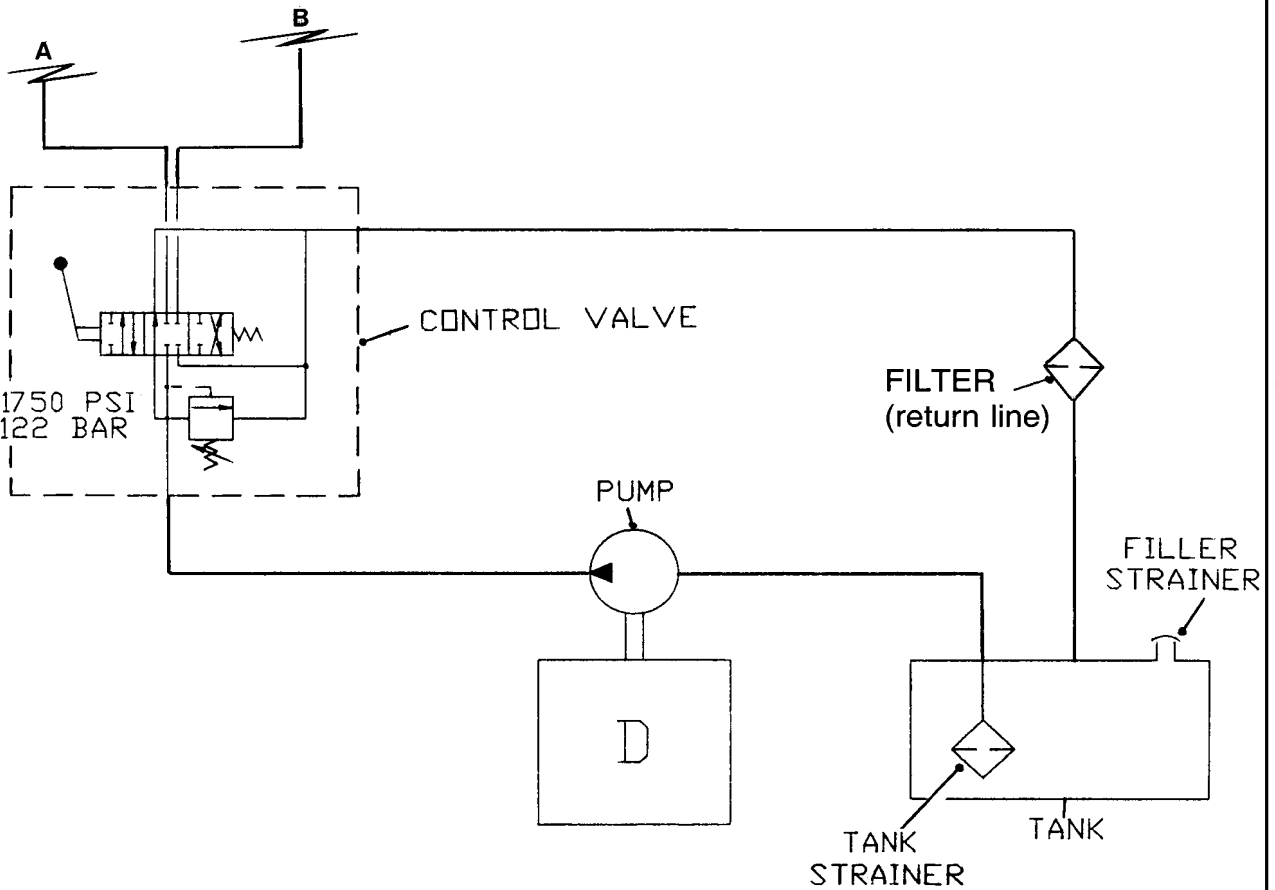
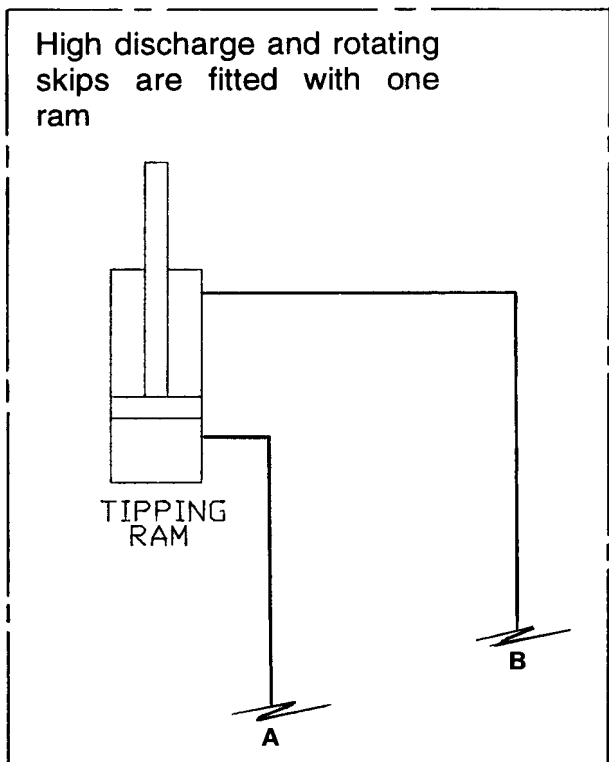

## Hydraulic System Checks

If the hydraulic system fails to operate completely, or does so extremely slowly, carry out the following procedures.

Check that the hydraulic tank is full of oil to the correct level. The level is correct when oil is 50mm from the top of the filler neck.

Check that the filter has been regularly cleaned in accordance with the maintenance schedule. If not, clean filter.

Check that the hydraulic pressures are correct as follows:

### Tipping circuit

Fit a 2000 lb/in<sup>2</sup> gauge into the hydraulic system at the base of a skip ram.

Operate control lever to tip skip and check the pressure reading on the gauge when the rams are fully extended and the relief valve is 'blowing'. See "Specifications" for correct pressure.

### Steering circuit

Fit a 2000 lb/in<sup>2</sup> gauge into the hydraulic system at the base of the steering ram.

Turn the steering wheel until the machine is at 'Full Lock' and check the pressure reading on the gauge. See "Specifications" for correct pressure.

**If these procedures do not correct the fault, contact your Distributor.**

Periodically check the hose between the pump and the hydraulic tank to ensure that it is not deformed. Any deformation in the hose may result in a restricted flow and damage to the pump.

**Every 10 operating hours, or daily**

## Check hydraulic oil level

Do not check oil level before closing the tipping rams, and the engine has been stopped for 2 minutes.

Always clean the surrounding area before removing the cap to prevent dirt from entering the tank.

The oil level is correct when it is 50mm (2") from the top of the neck.

Do not overfill; it will cause leakage from the breather!

**First 100 operating hours**

## Clean / change tank strainer

**WARNING** Before cleaning the tank strainer, stop the engine and dump hydraulic pressure.



Place a clean suitable container beneath the hydraulic tank strainer. Clean the area surrounding the strainer.

Disconnect the hose, then carefully unscrew the strainer (C) from the tank allowing the oil to drain into the container.

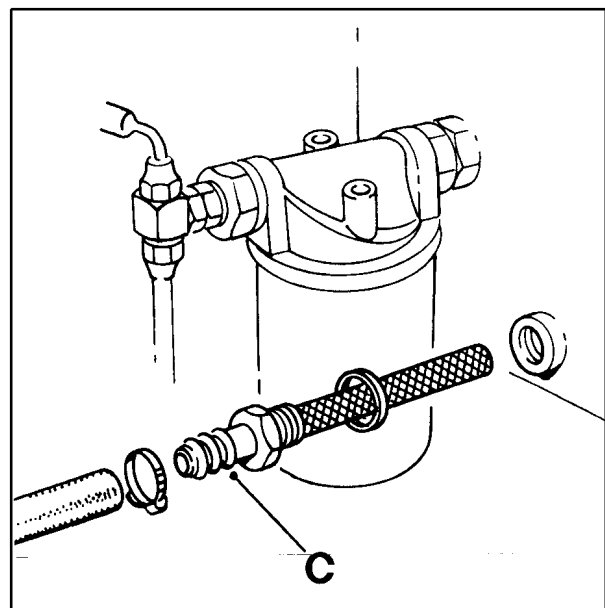



*Provided that the oil does not become contaminated it can be used to refill the tank after the strainer has been cleaned and replaced.*

Wash the strainer in white spirit and check it for any damage. *If the strainer cannot be thoroughly cleaned, fit a new one.*

Screw the strainer back into the tank. Reconnect the hose.

Fill the tank with oil. (The oil level is correct when it is 50mm below the top of the filler neck. *For the correct type of oil, see "Specifications"*)

Run the engine to circulate the oil.

Operate the hydraulic control to purge any air from the system.

Stop the engine and top up the tank as required.

Check the areas around the strainer for leaks.

**Every 300 operating hours****Change filter element**

Change the filter element, using the procedure described in the previous "*First 100 operating hours*".

**Every 1000 operating hour****Clean/change tank strainer**

Clean or change the hydraulic tank strainer **(C)**, using the procedure described in the previous "*First 100 operating hours*".

**First 100 operating hours****Change Hydraulic Filter Element**

**WARNING** *Before changing the filter element, stop the engine and dump hydraulic pressure.*



Remove and discard element cartridge **(S)**. Clean joint area, wipe with hydraulic oil, and fit new element cartridge. Do not over tighten.

Run engine to circulate the oil.

Operate the hydraulic control to purge any air from the system.

Stop the engine and top up the tank as required. *(For the correct type of oil, see "Specifications")*

Check the area around the element for leaks.

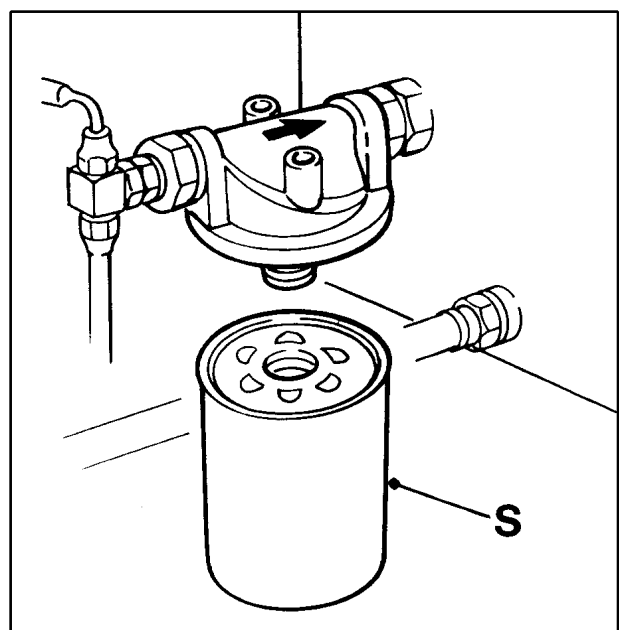

*Every 1000 operating hours*

### **Change hydraulic oil**

Run the engine and operate the hydraulics to warm the oil.

Fully close the tipping rams.

Switch off the engine and dump hydraulic pressure.

Clean the area surrounding the hydraulic tank strainer and filler cap.

Place a suitable container on the ground beneath the strainer to catch oil.

**CAUTION:** Before removing the strainer be sure to stand to one side to avoid the oil that will spill from the hole.

Carefully remove the strainer and drain the oil from the tank.

Flush out the tank with clean hydraulic oil, taking extreme care to remove all dirt and foreign matter.

Refit the strainer.

Clean the filler cap breather.

Refill the tank with clean oil of the correct type and grade. For the correct type of oil, see "*Specifications*".

Run the engine to circulate the oil.

Operate the hydraulic control to purge any air from the system.

Stop the engine and top up the tank as required.

Check the area around the strainer for leaks.

**GREASING**

**Every 50 operating hours, or weekly**

**WARNING** *Always use lubricants of the grade specified.*

 *Always lubricate and service BEFORE work commences, and WITHIN the periods specified.*

**Grease points**

Clean nipples **BEFORE** and **AFTER** greasing. Apply the grease gun until clean grease appears.

**Location of grease points**

- A** Tipping rams (2 on each ram)  
[No grease points on Rotating or High discharge skip tipping rams]
  - B** Skip pivots (2)
  - C** Propeller shaft (3)
  - D** Brake pedal pivot (2)
  - E** Clutch pedal pivot (2)
  - F** Accelerator pivot (2)
  - G** Front/rear chassis centre pivot (2)
  - H** Rear axle centre pivot (2)
  - I** Handbrake cable (1)
  - J** Gearbox clutch shaft pivot (1 each side of gearbox bell-housing)
- # Clean and lubricate all linkages not fitted with a grease nipple.

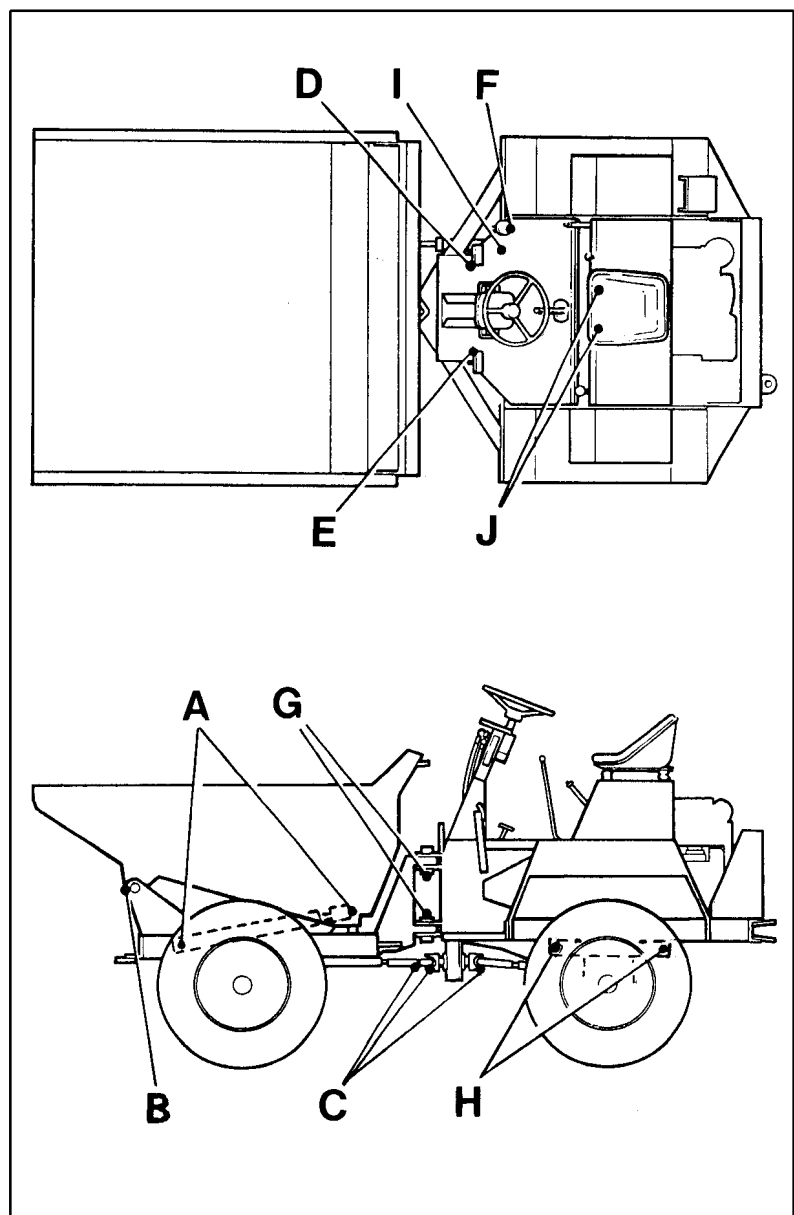

## BRAKING SYSTEM

### The service brake system

The service brakes consist of totally sealed oil immersed multi-discs fitted within the front and rear axles.

The brake system is designed to require the minimum of maintenance, and no defects should normally occur.

If air is present in the system, it will be indicated by sluggish response and by spongy action of the brake pedal.

**Note:** Always ensure that free play of 1 to 2 mm exists between the master cylinder push rod and the piston when the brake pedal is released.

#### To bleed the system, proceed as follows:

**A** Check that all connections are tight and the bleed screws are closed.

**B** Check that there is sufficient oil in the hydraulic tank.

**C** Attach bleeder tube (1) to the bleed screw (2) on the front axle and immerse the other end of the tube in a small quantity of hydraulic oil contained in a glass jar (3).

Slacken bleed screw and depress the brake pedal to its full extent. Hold the pedal down and tighten bleed screw. Release pedal and wait 5 to 10 seconds. Slacken the bleed screw and repeat process until the oil pumped into the jar contains no air bubbles. Hold down the pedal and close the bleed screw. Remove bleeder tube and release the pedal.

**D** Lock the bleed screw.

**F** Repeat the above procedure on the rear axle.

**G** Apply normal working load on brake pedal for two or three minutes and examine the entire system for leaks. Check the oil level in the hydraulic tank.

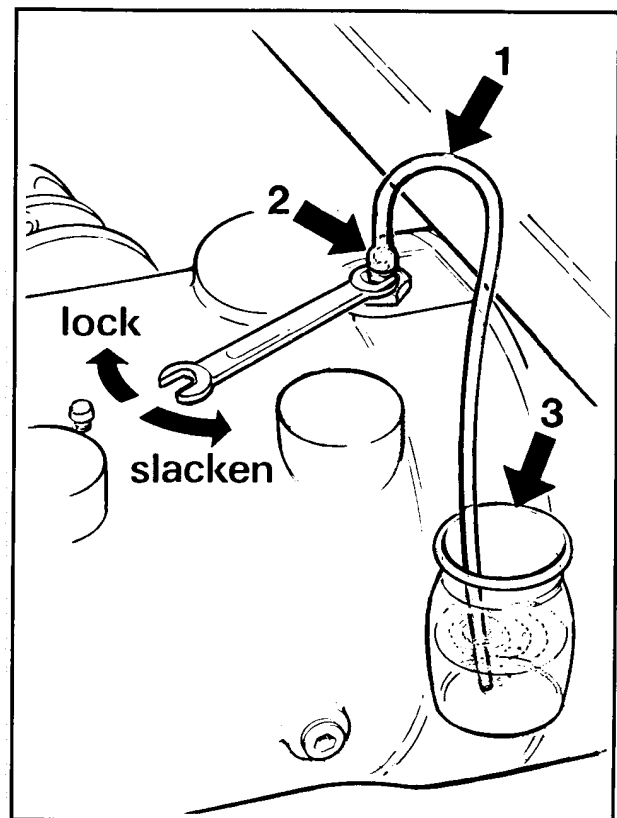

**WHEELS & TYRES**

***Every 10 operating hours, or daily***

**Wheel nuts**

Tighten wheel nuts whenever necessary, every ten hours or daily.

After a wheel change, the nuts should be checked several times a day until they maintain their correct setting.

*For wheel nut tightening torque, see "Specifications".*

***Every 50 operating hours, or weekly***

**Tyre pressures**

**WARNING** *ALWAYS ensure that when adding air to a tyre the area is clear of personnel.*



*NEVER over-inflate a tyre beyond its specified pressure.*

*NEVER adjust the tyre pressure in an attempt to improve traction on soft ground or obtain a softer ride on hard ground. Incorrectly adjusted tyres can affect the steering and handling characteristics.*

Check the tyre pressures only when the tyres are cold.

*For correct pressures see "Specifications".*

**Tyre condition**

Check the tyres for damage and deterioration.

## AXLES

**Every 10 operating hours, or daily**

### Check for leaks

Check for oil leaks around joints and seals.

**Every 50 operating hours, or weekly**

### Tighten securing nuts

Tighten axle arm/main case joint securing nuts and half shaft nuts.

### Axle oil level

Do not check the oil level until the machine has stood for 2 minutes.

Clean the area surrounding level plug **(E)** before removing it.

The oil is correct when level with the bottom of the level plug hole.

If the level is low, top-up with clean oil of the correct grade through the filler **(D)**.

Replace plugs.

For the correct type and grade of oil, see "*Specifications*".

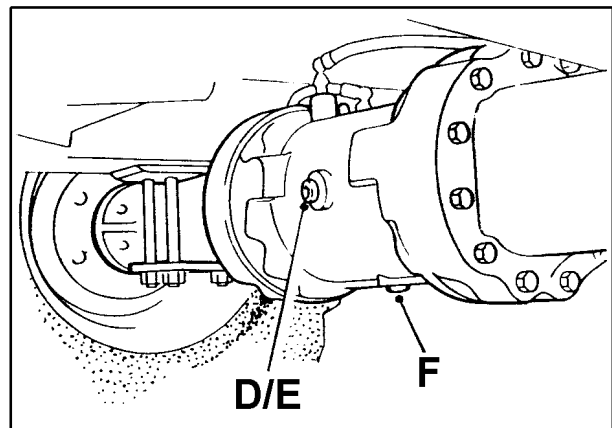

**Every 1000 operating hour**

### Axle oil change

Change the lubrication oil in the front axle as follows:

Clean the area surrounding the filler **(D)**, level **(E)** and drain **(F)** plugs.

Place a suitable container beneath the drain plug.

**CAUTION:** Before removing the plugs be sure to stand to one side to avoid the oil that will spill from the drain hole.

Remove drain plug **(F)** and drain oil from the casing. Replace drain plug.

Refill at the filler plug **(D)** with clean oil of the correct grade.

The level is correct when oil reaches the bottom of the level plug hole **(E)**.

Replace all plugs.

*For the correct type and grade of oil, see "Specifications".*

## DIMENSIONS

### Machines with forward tip skip

	4B2500		4B3000	
<b>A</b> Overall height	1830mm	6'0"	1900mm	6'2"
<b>B</b> Skip loading height	1330mm	4'4"	\$ 1525mm	5'0"
			# 1400mm	4'7"
<b>C</b> Wheelbase	1790mm	5'10"	1940mm	6'4"
<b>D</b> Overall length	3960mm	13'0"	4036mm	13'3"
<b>E</b> Ground clearance	310mm	1'0"	350mm	1'2"
<b>F</b> Overall width	1830mm	6'0"	2130mm	6'11"
<b>G</b> Discharge height	450mm	1'6"	340mm	1'1"
<b>H</b> Overall height when tipped	2440mm	8'0"	2440mm	8'0"
<b>J</b> Discharge forward of tyre	460mm	1'6"	480mm	1'7"
<b>K</b> Overhang	1063mm	3'6"	1096mm	3'7"
<b>L</b> Wheeltrack	1525mm	5'0"	1740mm	5'9"
<b>M</b> Prow width	1700mm	5'7"	2000mm	6'7"
Axle articulation	355mm	1'2"	355mm	1'2"
Turning circle	7570mm	24'10"	8150mm	26'9"
Unladen weight	2230kg	4917lb	2430kg	5358lb

\$ Concrete carrier  
# Earth carrier

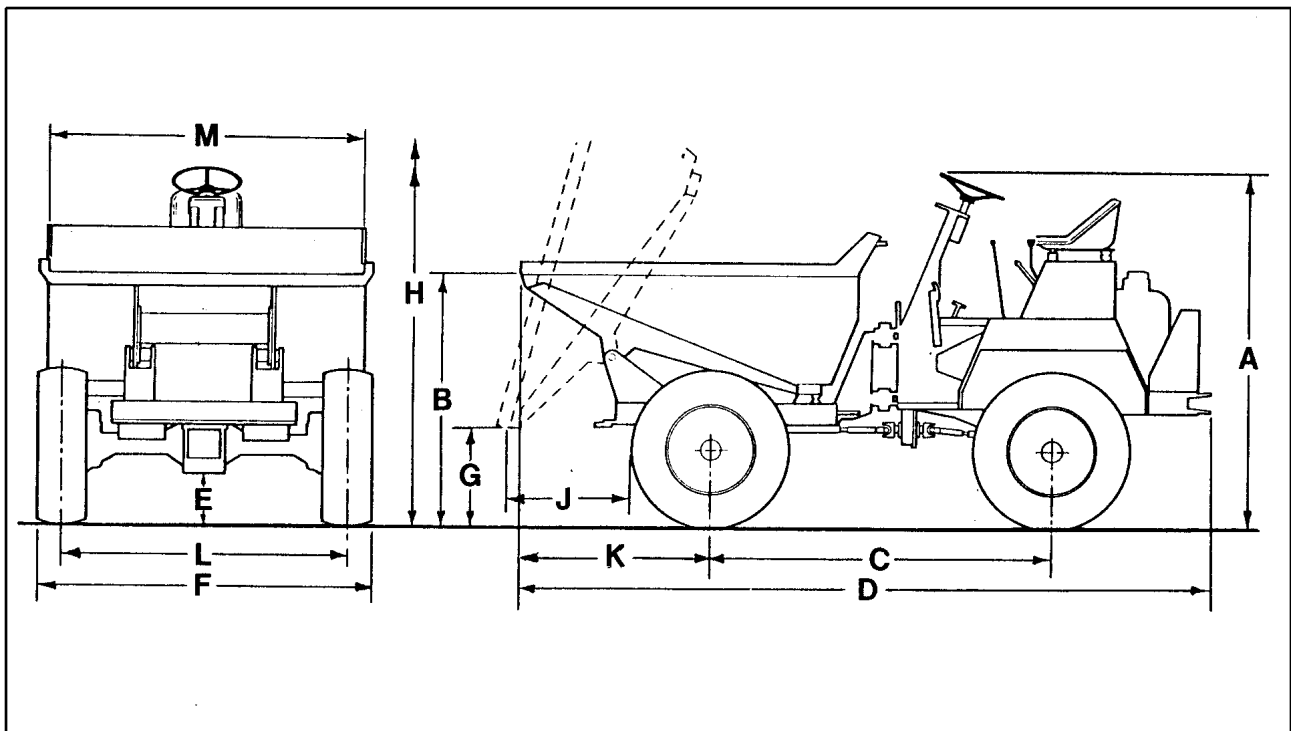

## DIMENSIONS

## Machines with high discharge skip

## 4B2500

<b>A</b>	Overall height	1830mm	6'0"
<b>B</b>	Skip loading height	1550mm	5'1"
<b>C</b>	Wheelbase	1790mm	5'10"
<b>D</b>	Overall length	3500mm	11'6"
<b>E</b>	Ground clearance	310mm	1'0"
<b>F</b>	Overall width	1800mm	5'10"
<b>G</b>	Discharge height	1454mm	4'9"
<b>H</b>	Overall height when tipped	2775mm	9'1"
<b>J</b>	Discharge forward of tyre	300mm	1'0"
<b>K</b>	Overhang	582mm	1'11"
<b>L</b>	Wheeltrack	1525mm	5'0"
<b>M</b>	Prow width	680mm	2'3"
	Axle articulation	355mm	1'2"
	Turning circle	7570mm	24'10"
	Unladen weight	2260kg	4983lb

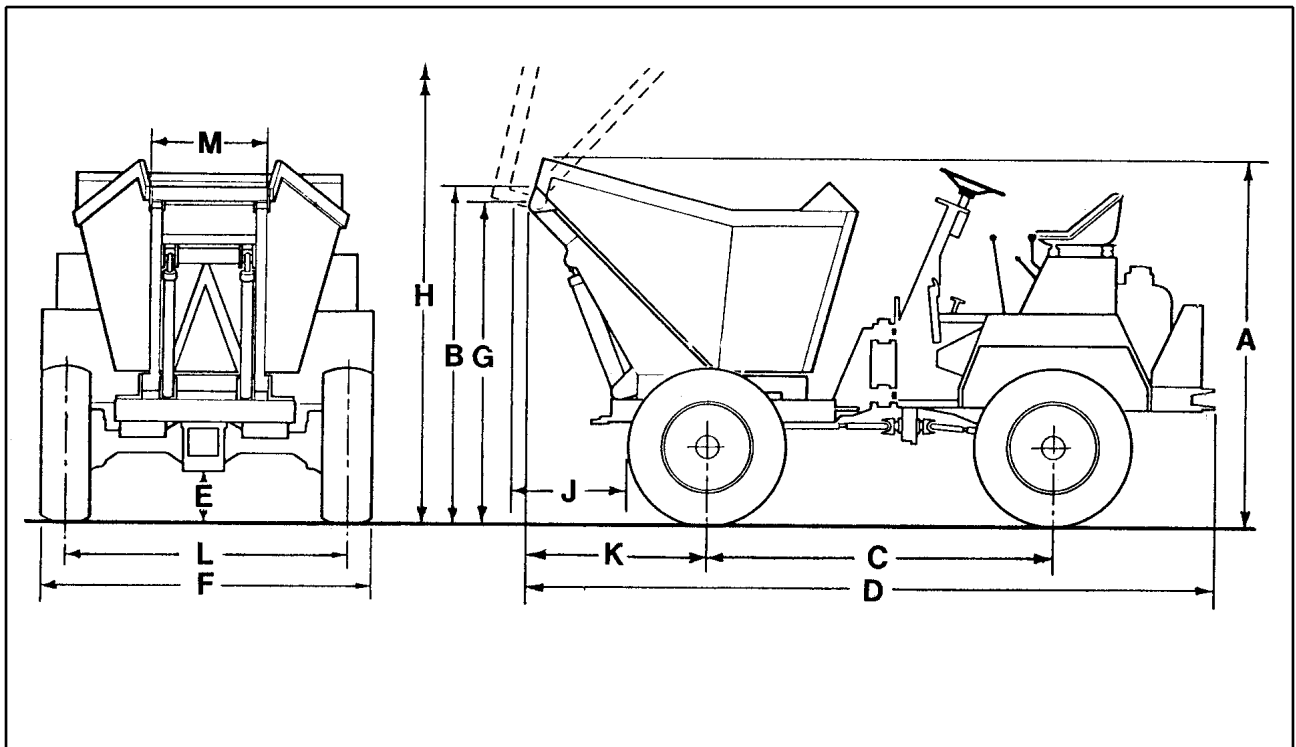



## DIMENSIONS

### Machines with rotating skip

#### 4B2500

<b>A</b>	Overall height	1830mm	6'0"
<b>B</b>	Skip loading height	1440mm	4'9"
<b>C</b>	Wheelbase	1790mm	5'10"
<b>D</b>	Overall length	3937mm	12'11"
<b>E</b>	Ground clearance	310mm	1'0"
<b>F</b>	Overall width	1800mm	5'10"
<b>G</b>	Discharge height	570mm	1'11"
<b>H</b>	Overall height when tipped	2528mm	8'4"
<b>J</b>	Discharge forward of tyre	713mm	2'4"
<b>K</b>	Overhang	582mm	1'11"
<b>L</b>	Wheeltrack	1525mm	5'0"
<b>M</b>	Prow width	1067mm	3'6"
	Axle articulation	355mm	1'2"
	Turning circle	7570mm	24'10"
	Unladen weight	2440kg	5380lb

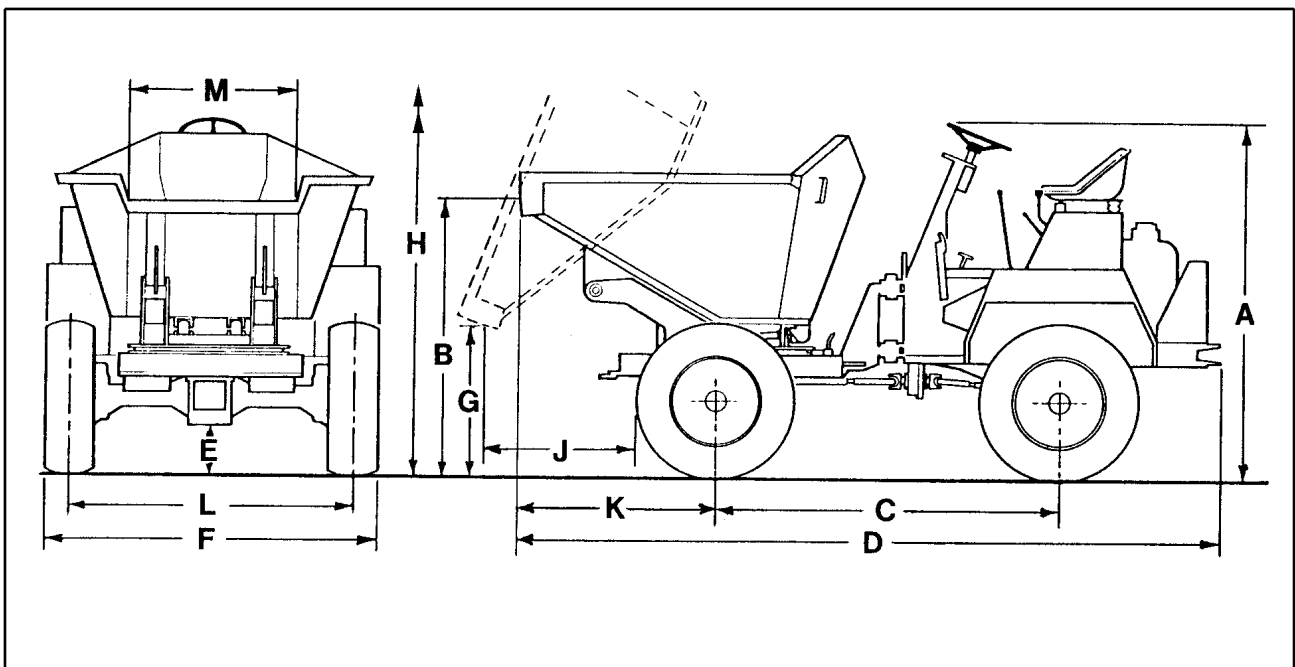

## SPECIFICATIONS

## ENGINES

<b>up to 1985</b>	Petter PH2: Lister ST3:	"See relevant Engine Operator's handbook". "See relevant Engine Operator's handbook".
<b>1985 to 1989</b>	Lister-Petter PH2:	"See relevant Engine Operator's handbook".
<b>1985 to date</b>	Lister-Petter TS3	Twin cylinder, direct injection, naturally aspirated, flywheel fan air cooled diesel. Rotation: Anti-clockwise when looking on the flywheel. Output: 22.6 kW (30.3 bhp) @ 2500 rev/min.

**ELECTRICS** (Where fitted) 12 volt negative earth.

**FUEL SYSTEM**

System:	Two element fuel pump.
Fuel specification:	BS 2869:1988 Class A2, or BS EN590:1995 Class A1.
Fuel filter:	Strainer within fuel tank.
Air cleaner:	Renewable element.

**AXLES** Front & rear: Heavy duty with fully floating half shafts.

**BRAKES**

Service:	Front and rear axle braking. Totally sealed oil immersed multi-plate disc brakes, featuring fully automatic adjustment for wear.
Parking:	Hand operated, ratchet type, actuating a disc brake caliper mounted on the transmission.

**TRANSMISSION** Heavy duty constant mesh gearbox, with 3 forward and 1 reverse gear.

**HYDRAULICS**

Pump:	Gear type.
Control valve:	Sectional or monobloc with pressure relief valve.
Filter:	Strainer within the hydraulic tank, plus an in-line filter.

## ROAD SPEEDS *Lister ST2 and Lister-Petter TS/TR3*

	1st Gear Km/h. (mph)	2nd Gear km/h (mph)	3rd Gear km/h (mph)	Reverse km/h (mph)
<b>4B2500</b>	3.66(2.28)	8.58(5.34)	15.78 (9.82)	4.10(2.55)
<b>4B3000</b>	3.98(2.48)	9.26(5.76)	17.13 (10.66)	4.45(2.77)

## LUBRICANTS AND FLUIDS *Total oils (factory fill)*

### Capacities

TS/TR3 Engine Lubrication	Rubia H 10W/30	5.5 litres
<i>Note: For engine oils used in temperatures above 30°C consult the Engine Handbook.</i>		
Gearbox	Rubia B 20W/30	2.0 litres (approx)
Transfer Box	EP85W/140 or EP140 gear oil	1.0 litre (approx)
Axles	Universal plant oil or Transmission MP	4.6 litres
Brake System (Supplied from hydraulic tank)	Azzola ZS46	-----
Hydraulic tank	Azzola ZS46	<b>4B2500</b> 29.5 litres
		<b>4B3000</b> 36.4 litres
Fuel tank		<b>4B2500</b> 29.5 litres
		<b>4B3000</b> 36.4 litres
General Grease	Multis EP2	as required
General Lubrication Oil	Rubia B 20W/30	as required

## SKIP CAPACITIES

<b>Forward tip</b>	<b>4B2500</b>		<b>4B3000</b>	
Payload	2500 kgs	5510 lbs	3000 kgs	6615 lbs
Liquid capacity	1000 ltrs	35 cu.ft	1300 ltrs	46 cu.ft
Full & levelled	1.29 cu.m	45 cu.ft	1.7 cu.m	61 cu.ft
Heaped	1.75 cu.m	62 cu.ft	2.3 cu.m	82 cu.ft
<b>High discharge</b>				
		<b>4B2500</b>		
Payload	2000 kgs	4410 lbs		
Liquid capacity	760 ltrs	27 cu.ft		
'from year 2000'	1000 ltrs	35 cu.ft		
<b>Rotating</b>				
		<b>4B2500</b>		
Narrow mouth skip - Payload	1630 kgs	3600 lbs		
Liquid capacity	680 ltrs	24 cu.ft		
Wide mouth skip - Payload	2245 kgs	4950 lbs		
Liquid capacity	935 ltrs	33 cu.ft		

**TYRE PRESSURES**

Front & rear	2.75 bar (40 lb in <sup>2</sup> )
--------------	-----------------------------------

**HYDRAULIC PRESSURE**

120.7 bar (1750psi)
---------------------

**TYRES**

<b>4B2500</b>	11.5/80 x 15
---------------	--------------

<b>4B3000</b>	12.5/80 x 18
---------------	--------------

**ADJUSTMENTS**

Wheel nuts torque	200 lbf ft (271 Nm)
-------------------	---------------------

Engine	<i>(See Engine Workshop Manual)</i>
--------	-------------------------------------

**VIBRATION DECLARATION**

Whole body vibration level  $a_w$  (m/s<sup>2</sup>): 0.7 - 0.8 Typical\*

**\*Note:** *The absence of a harmonised test code together with the variable conditions under which this equipment may be used allows only representative figures to be quoted.*

Hand/arm vibration level  $a_{ha}$  (m/s<sup>2</sup>): Less than 2.5

*(Vibration declaration applicable only to EEC models)*

## MAIN ELECTRICAL CIRCUIT (without road lights)

Later dumpers with Lister-Petter 'NISCA' charging systems

### WIRING COLOUR CODES

1	STARTER MOTOR-REG'B'	RED (THICK)
2	START SWITCH TER 1-STARTER MOTOR	BROWN
3	START SWITCH TER 3-STARTER SOLENOID	WHITE/RED
4	START SWITCH TER 4-REG 'C'	RED (THIN)
5	REG'LE'-WARNING LAMP	BLACK
6	START SWITCH TER 4- LAMP	BLACK (BRIDGE WIRE)

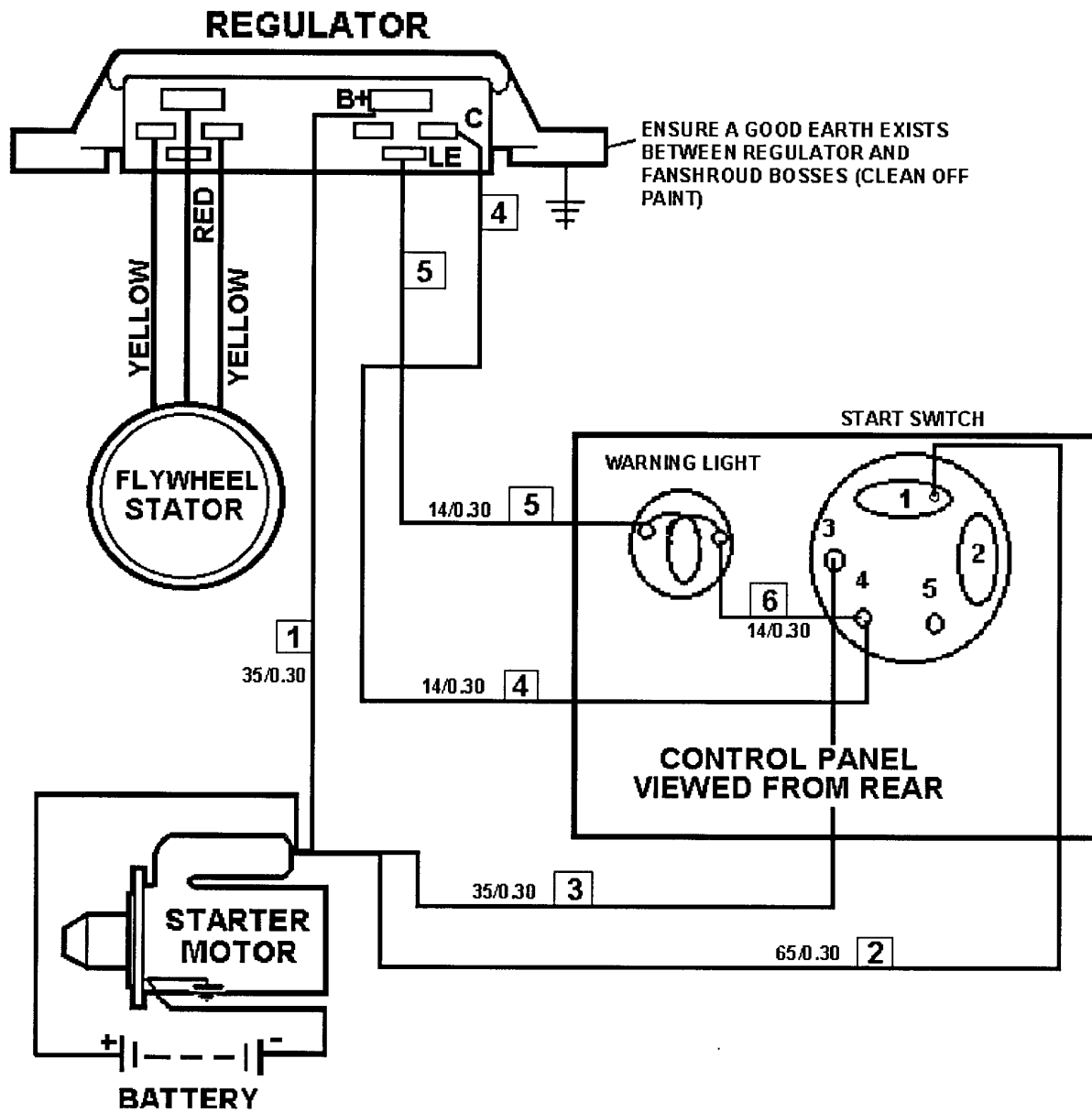

ROAD LIGHTS ELECTRICAL CIRCUIT

4B2500 dumpers from serial number 0797

4B3000 dumpers from serial number 0809

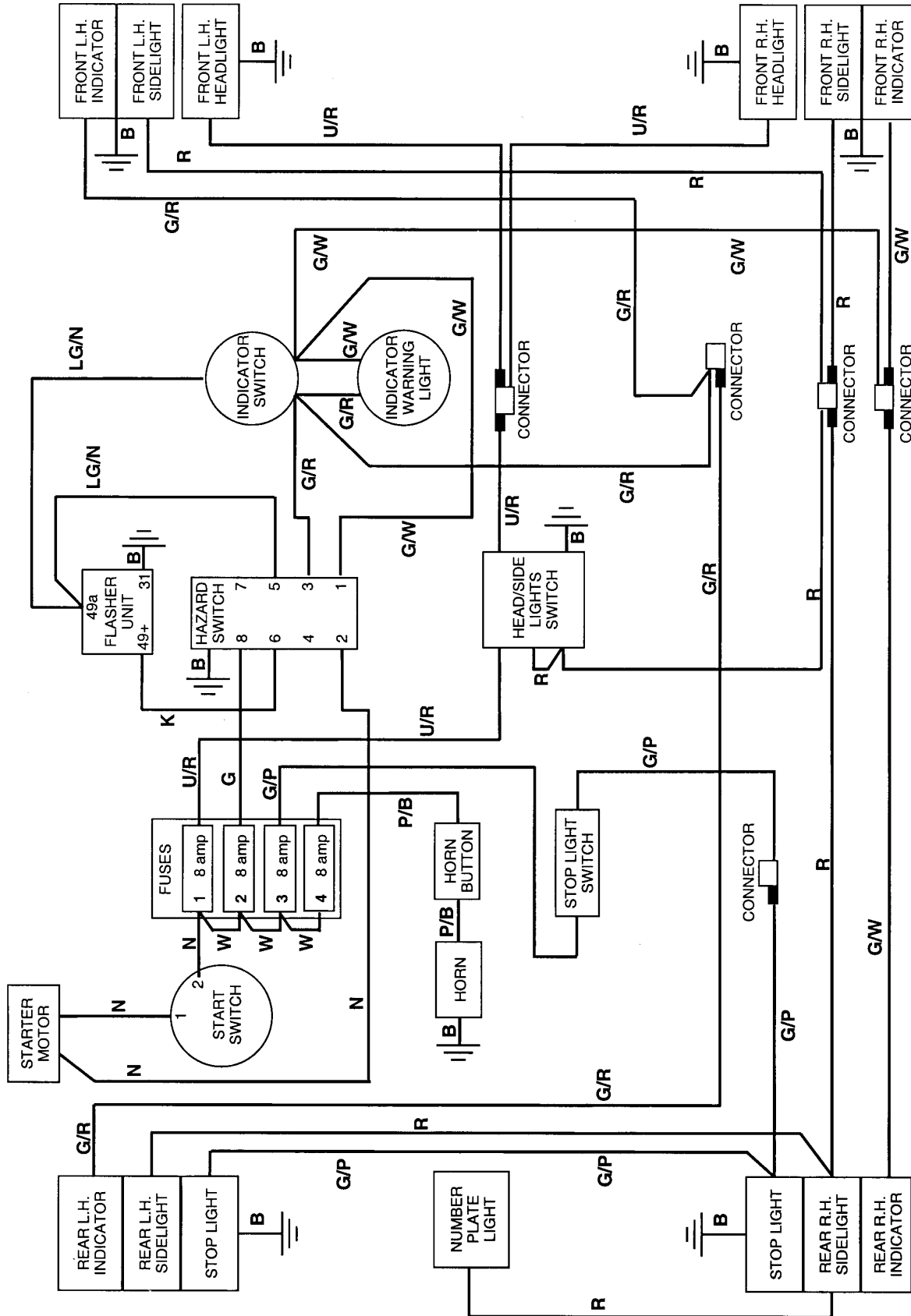

# ***PARTS***

- 1 BRAKES**
- 2 AXLES & STEERING**
- 3 ENGINES**
- 4 TRANSMISSIONS**
- 5 ELECTRICS**
- 6 SKIPS**
- 7 HYDRAULICS**
- 8 CHASSIS & PANELS**
- 9 DECALS**

***< To front of book***

***Section***

**1**



# ***BRAKES***

<b><u>BRAKING SYSTEM</u></b>	<b><u>1 - A - 1</u></b>
<b><u>MASTER CYLINDER</u></b>	<b><u>1 - A - 2</u></b>
<b><u>BRAKE PEDAL</u></b>	<b><u>1 - A - 3</u></b>
<b><u>HANDBRAKE</u></b>	<b><u>1 - B - 1</u></b>
<b><u>CALIPER, handbrake</u></b>	<b><u>1 - B - 2</u></b>

***< To begining of Parts***

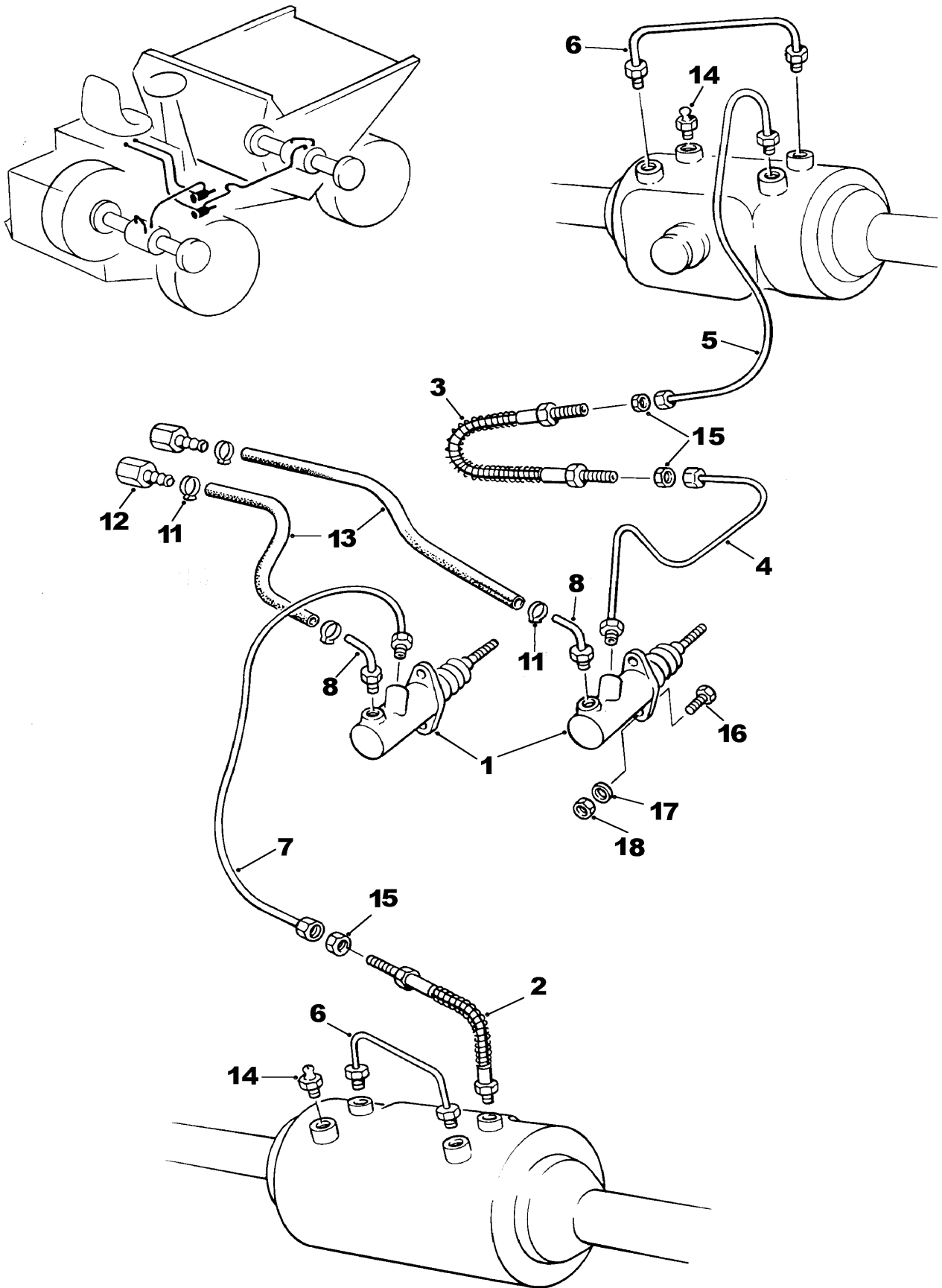

**BRAKING SYSTEM****1 - A - 1****Newage axles, front & rear braking**

<b>Item</b>	<b>Part no</b>	<b>Serial no</b>	<b>Description</b>	<b>Qty</b>
1	.....		MASTER CYLINDER ( <i>see page 1-A-2</i> )	2
2	10516A02		BRAKE HOSE, rear	1
3	10517A02		BRAKE HOSE, front	1
4	V2000302		PIPE, m/cyl. to front brake hose	1
5	10577A0110		PIPE, front brake hose to front axle	1
6	10577A0202		PIPE, axle bridge	2
7	10577A0111		PIPE, m/cyl. to rear brake hose	1
8	10542A01		PIPE, stub	2
11	165S04		CLIP, hose	4
12	110S01A		NOZZLE	2
13	29S07		HOSE, m/cyl. to tank	2
14	182S20		SCREW, bleed	2
15	10582A01		NUT, locking	3
16	8S03C		BOLT	4
17	267S05		WASHER, flat	4
18	59S12		NUT	4

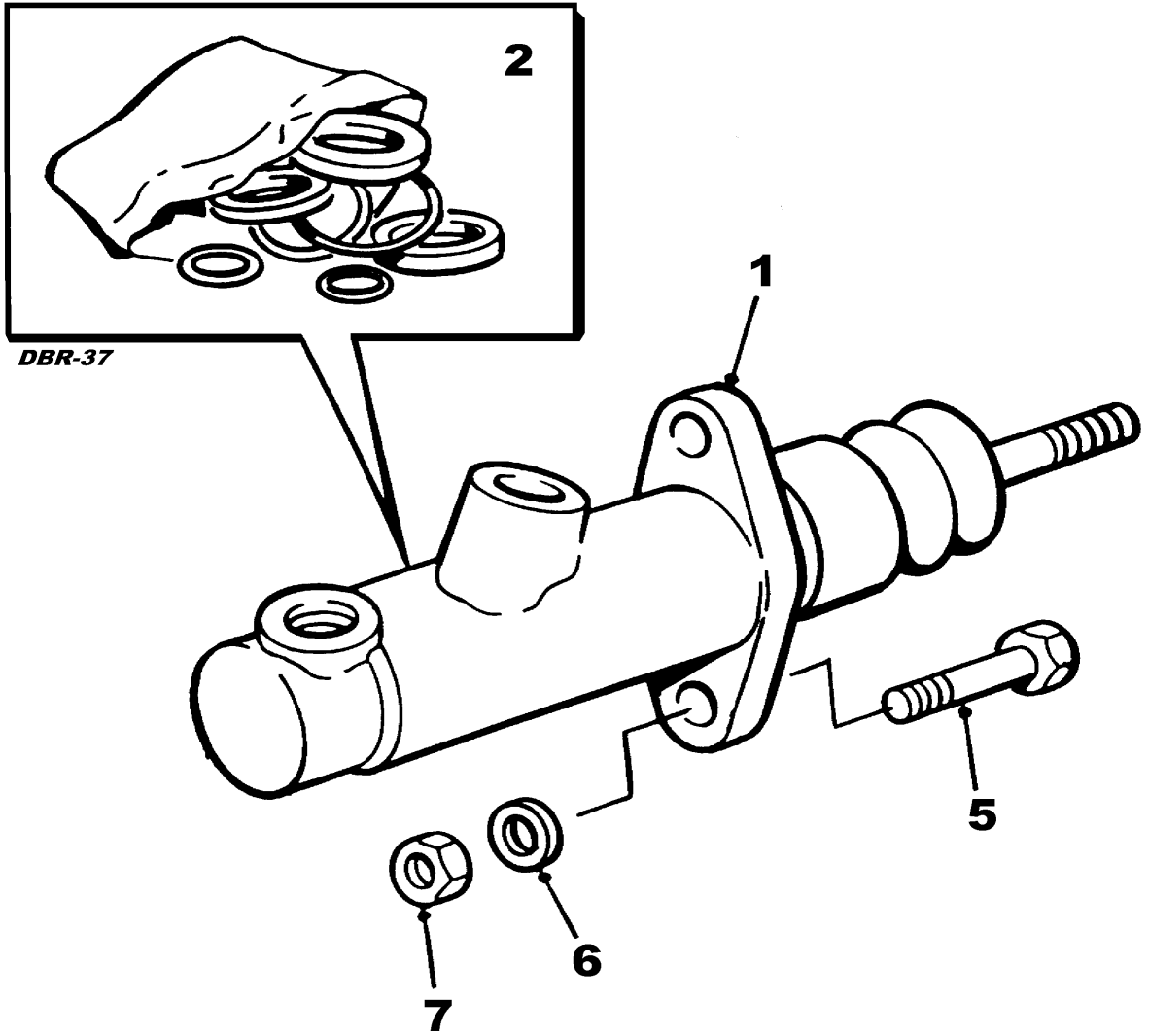

Item	Part no	Serial no	Description	Qty
------	---------	-----------	-------------	-----

*Dumpers are fitted with either GIRLING or FRENOS IRUNA Master Cylinders.  
Be sure to quote the name marked on the Master Cylinder before ordering parts.*

**GIRLING**

1	20102A02		MASTER CYL. with 3/8" UNF rod	1
1	V2004651		MASTER CYL. with M10 rod	1

**FRENOS IRUNA**

1	V2003671		MASTER CYL. with 3/8" UNF rod	1
2	10570A01		REPAIR KIT, m/cyl. <b>GIRLING</b>	
2	V601697		REPAIR KIT, m/cyl. <b>FRENOS IRUNA</b>	

5	8S03C		BOLT	2
6	267S05		WASHER, flat	2
7	59S12		NUT, self-locking	2

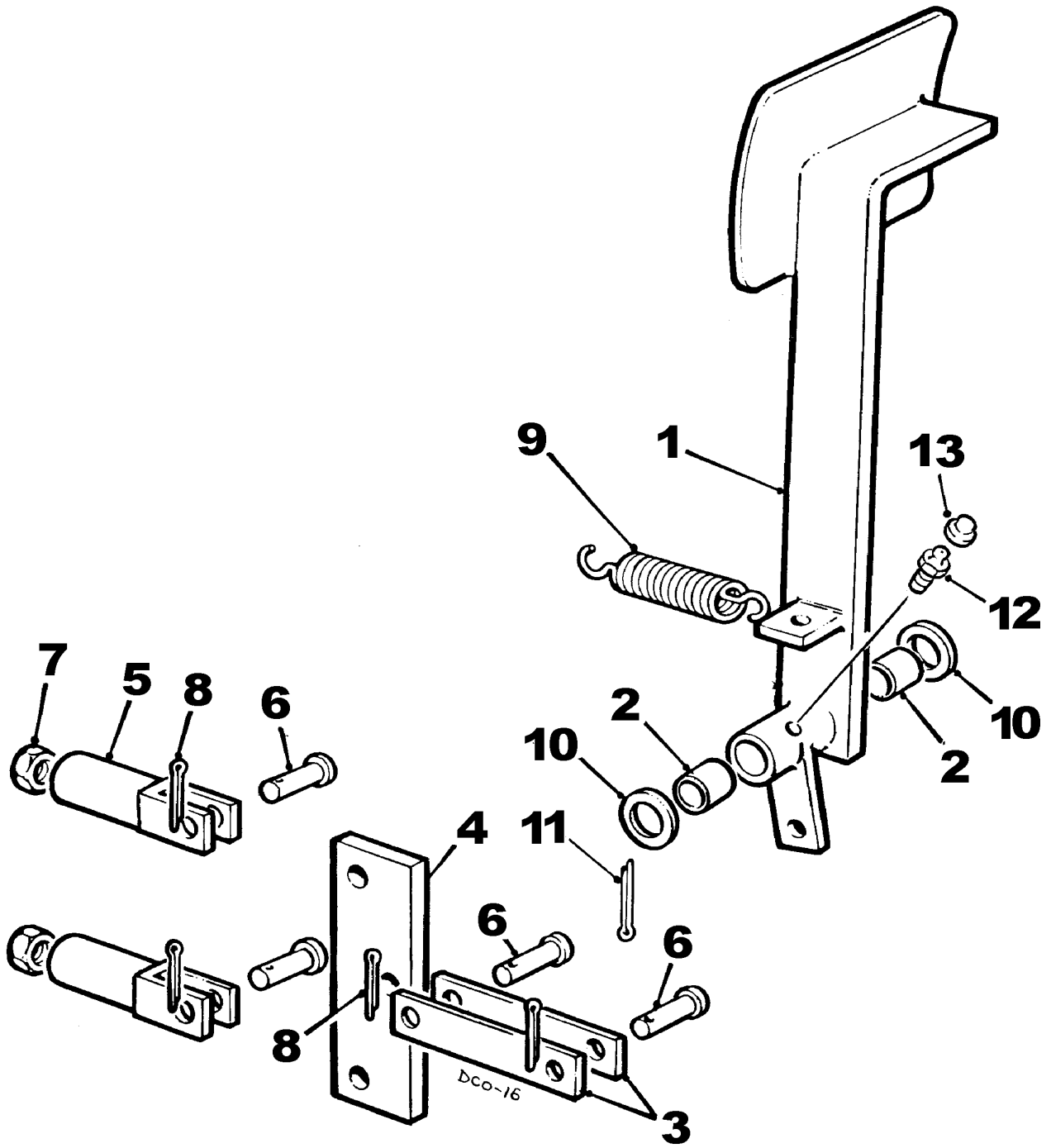

**BRAKE PEDAL****1 - A - 3**

<b>Item</b>	<b>Part no</b>	<b>Serial no</b>	<b>Description</b>	<b>Qty</b>
1	20232A01		PEDAL, brake	1
2	43S02		BUSH	2
3	10436A02		LINK, pedal	2
4	20117A06		COMPENSATOR	1
<b>4B2500 dumpers</b>				
5	10454A02	/ 0803	CLEVIS, 3/8"UNF	2
5	V2004650	0804 /	CLEVIS, M10	2
<b>4B3000 dumpers</b>				
5	10454A02	/ 0810	CLEVIS, 3/8"UNF	2
5	V2004650	0811 /	CLEVIS, M10	2
6	10650A18		PIN, clevis	4
<b>4B2500 dumpers</b>				
7	95S03	/ 0803	NUT, 3/8"UNF	2
7	7S04	0804 /	NUT, M10	2
<b>4B3000 dumpers</b>				
7	95S03	/ 0810	NUT, 3/8"UNF	2
7	7S04	0811 /	NUT, M10	2
8	44S02C		PIN, split	4
9	C173B		SPRING, return	1
10	10S06		WASHER, flat	2
11	44S04E		PIN, split	1
12	131S01		NIPPLE, grease	1
13	176S01		CAP, grease nipple	1

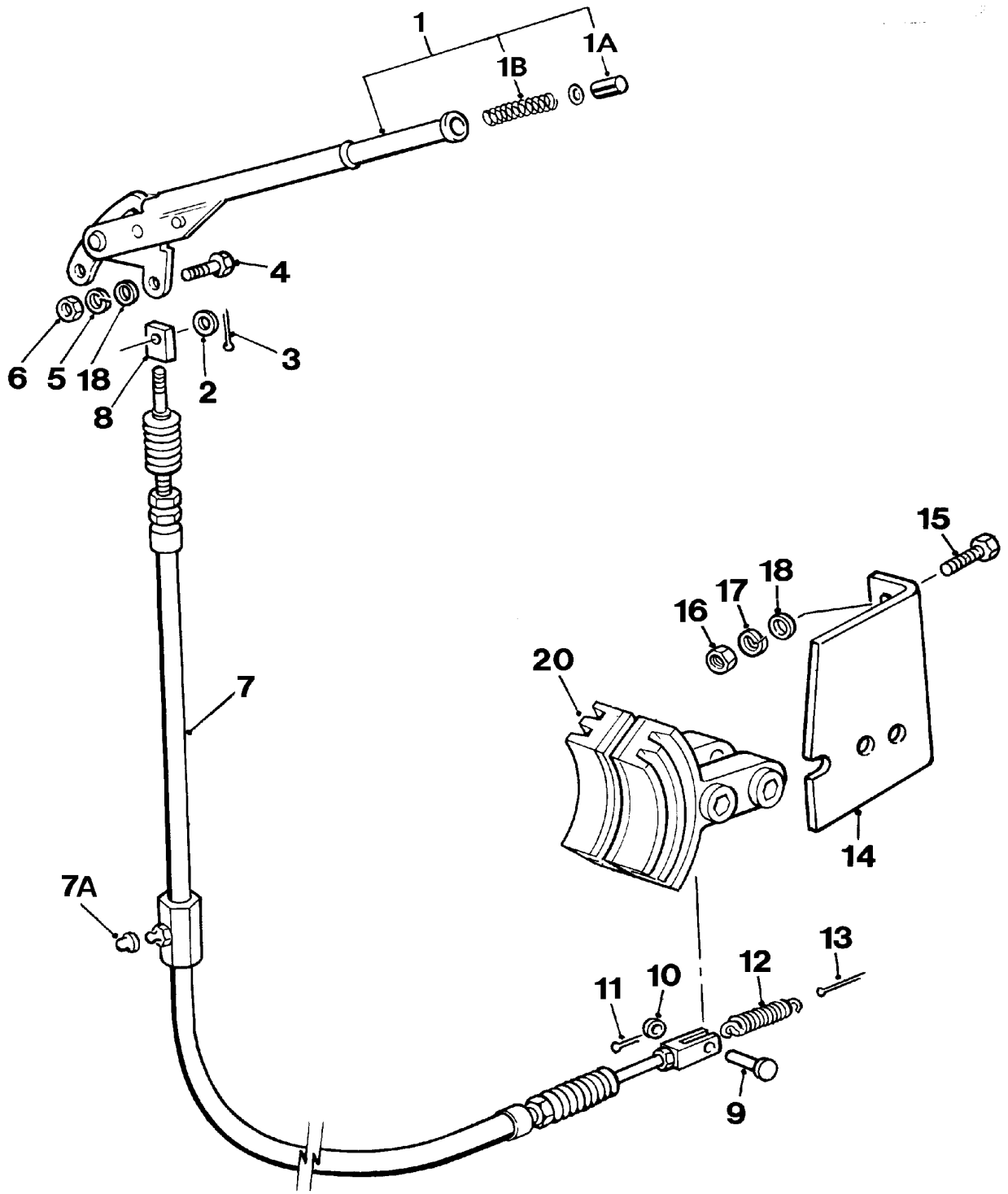



**HANDBRAKE****1 - B - 1**

<b>Item</b>	<b>Part no</b>	<b>Serial no</b>	<b>Description</b>	<b>Qty</b>
1	20208A01		LEVER, handbrake	1
1A	20208A0101		BUTTON	1
1B	20208A0102		SPRING	1
2	10S14		WASHER, flat	1
3	44S02B		PIN, split	1
4	11S04C		SCREW, set	2
5	17S05		WASHER, spring	2
6	7S04		NUT	2
7	10367A03		CABLE ( <i>includes items 9, 10, 11</i> )	1
7A	176S01		COVER, grease nipple	1
8	L309		BLOCK	1
9	10650A13		PIN, clevis ( <i>part of item 7</i> )	1
10	10S01		WASHER, flat ( <i>part of item 7</i> )	1
11	44S01C		PIN, split ( <i>part of item 7</i> )	1
12	C173D		SPRING, return	1
13	44S05E		PIN, split, return spring	1
14	20191A04		BRACKET, caliper support	1
15	11S04C		SCREW, set	2
16	7S04		NUT	2
17	17S05		WASHER, spring	2
18	267S06		WASHER, flat	4
20	10578A01		CALIPER ( <i>see page 1-B-1</i> )	1

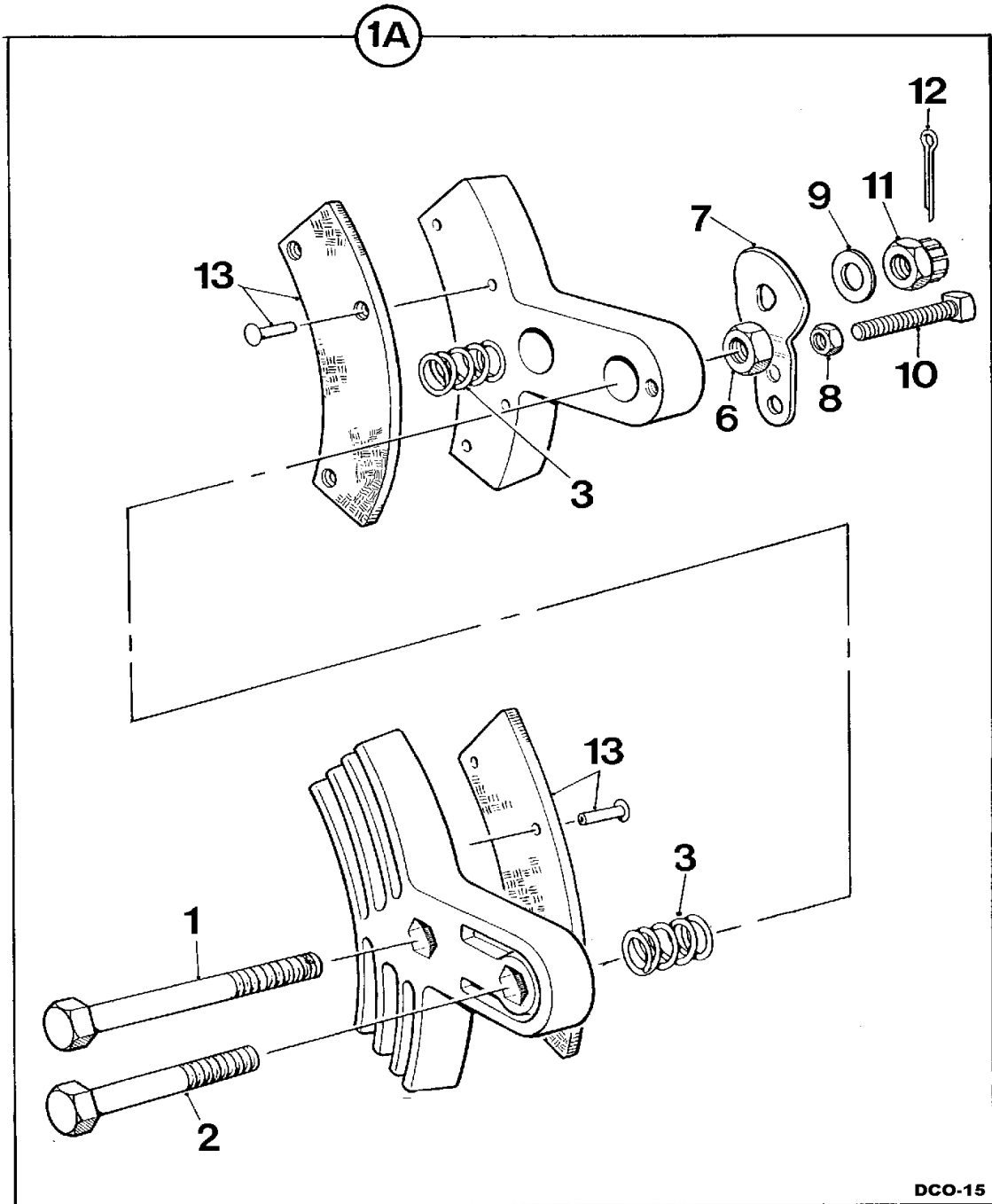

**CALIPER, handbrake****1 - B - 2**

<b>Item</b>	<b>Part no</b>	<b>Serial no</b>	<b>Description</b>	<b>Qty</b>
1A	10578A01		CALIPER, one pair, assembly	1
1	11116		SCREW, with hole for pin, item 12	1
2	28S02P		SCREW	1
3	.....		TENSION WASHER ( <i>obsolete</i> )	6
3	10578A0101		SPRING, centring	2
4	10578A0102		WASHER, tension	6
6	9S02		NUT	1
7	10578A0104		CAM	1
8	230S01		NUT, locking	1
9	10578A0105		WASHER	1
10	66S01H		SCREW, set	1
11	227S02		NUT, castle	1
12	44S01C		PIN, cotter	1
13	1072A4		PAD c/w rivets	2

***Section***

**2**

# ***AXLES***

**AXLES & MOUNTS** [2 - A - 1](#)

---

**AXLES, "Newage", driven with brakes**

**350RF** [2 - A - 2](#)

---

**360RF** [2 - A - 3](#)

---

**STEERING COLUMN** [2 - S - 1](#)

---

**WHEELS & TYRES** [2 - W - 1](#)

---

[\*\*< To begining of Parts\*\*](#)

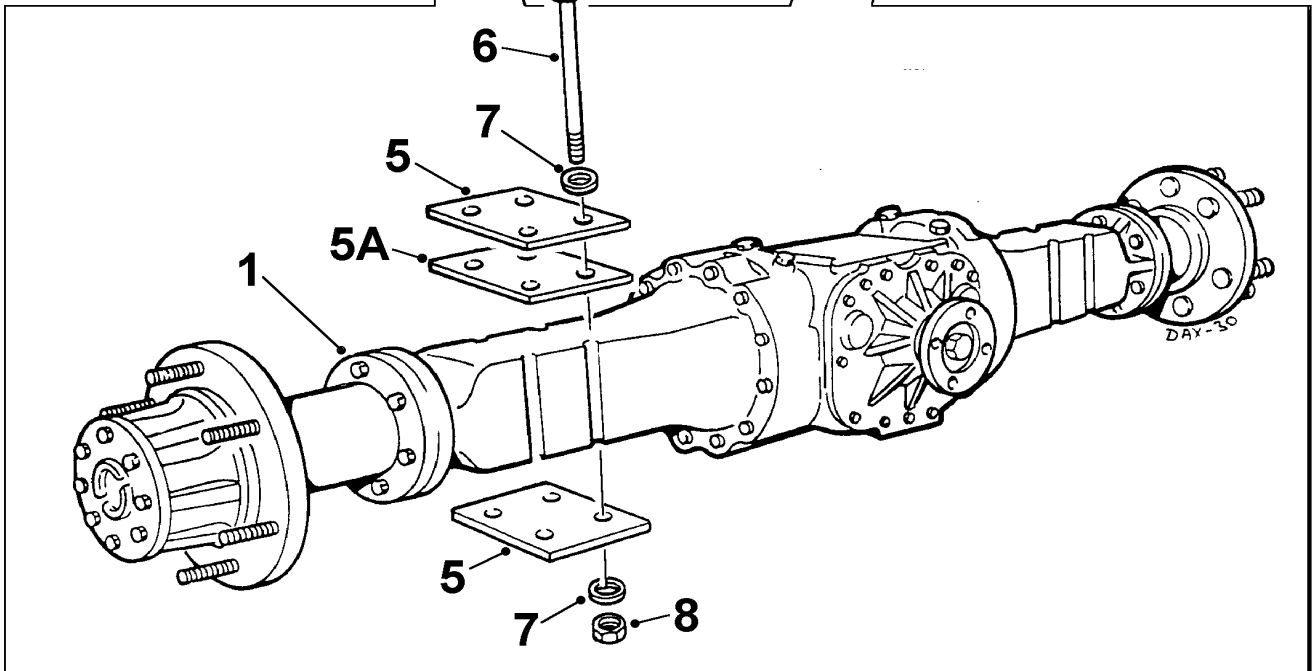
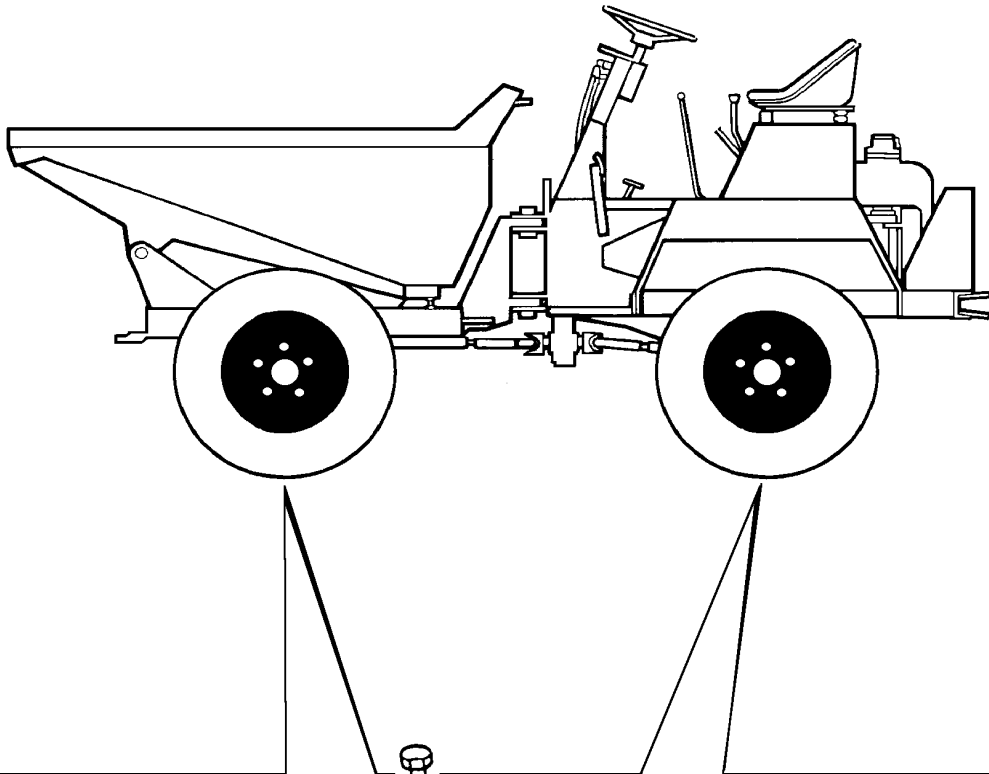

**AXLES & MOUNTS****2 - A - 1**

<b>Item</b>	<b>Part no</b>	<b>Serial no</b>	<b>Description</b>	<b>Qty</b>
1	—————	/ 700288	AXLE, type <b>350RF</b> (see page 2 - A - 2)	1
1	—————	700289 /	AXLE, type <b>360RF</b> (see page 2 - A - 3)	1
5	CSE193		PLATE, axle clamp	4
5A	V2001278		SPACER, front axle, 6mm	AR
5A	V2001279		SPACER, front axle, 8mm	AR
6	6S06W	/ 700288	BOLT, rear axle	8
6	6S06V	/ 700288	BOLT, front axle	8
6	6S06QQ	700289 /	BOLT	8
7	10S05		WASHER, flat	16
8	107S17		NUT, self-locking	8

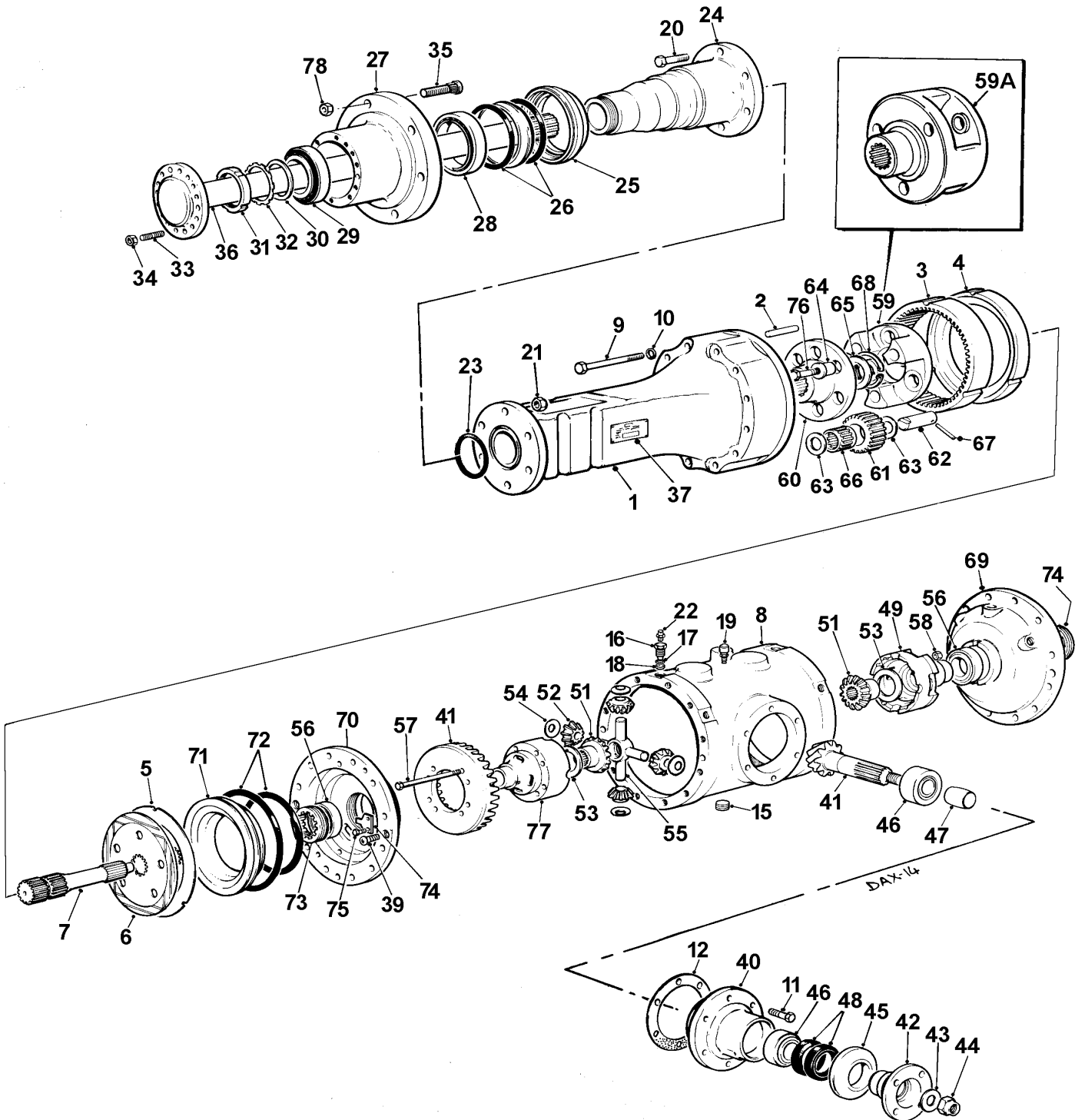



**AXLES, 350RF (with brakes)**
**2 - A - 2**

Item	Part no	Serial no	Description	Qty
<b>This axle was replaced by Axle 360RF</b>				
<i>(see page 2 - A - 3)</i>				
	30082A02	/ 700288	AXLE, assembly, <b>4B2500</b>	2
	30100A02	/ 700288	AXLE, assembly, <b>4B3000</b>	2
1	30082A0201		ARM, axle, <b>4B2500</b>	2
1	30100A0224		ARM, axle, <b>4B3000</b>	2
2	30082A0202		PIN, <b>4B2500</b>	6
2	30100A0201		PIN, <b>4B3000</b>	6
3	30082A0203		ANNULUS	2
4	30082A0204		PLATE, brake spacing	2
5	30082A0205		PLATE, fixed, brake	2
6	30082A0206		DISC, oil immersed brake	2
7	30082A0207		SUN GEAR	2
8	30082A0208		CASING, main	1
9	4S04R		BOLT, <b>4B2500</b>	24
9	8S04Q		BOLT, <b>4B3000</b>	24
10	17S04		WASHER, spring, <b>4B2500</b>	6
10	17S05		WASHER, spring, <b>4B3000</b>	6
11	11S04C		SCREW, set	6
12	30082A0209		SHIM, pinion adjusting	AR
12	30082A0210		SHIM, pinion adjusting	AR
12	30082A0211		SHIM, pinion adjusting	AR
15	30082A0212		PLUG	2
16	30082A0213		ADAPTOR	4
17	49S02		O' RING	4
18	30082A0269		SEAL, bonded	4
19	30082A0214		VALVE, relief	1
20	8S05E		BOLT, <b>4B2500</b>	12
20	30100A0226		BOLT, <b>4B3000</b>	12
21	59S04		NUT, nylon insert, <b>4B2500</b>	12
21	30100A0227		NUT, nylon insert, <b>4B3000</b>	12
22	30082A0215		VALVE, brake bleed	2
23	30082A0268		O' RING	2
24	30082A0216		STUB AXLE, <b>4B2500</b>	2
24	30100A0203		STUB AXLE, <b>4B3000</b>	2
25	30082A0217		HOUSING, oil seal	2
26	30082A0218		SEAL, oil hub	2
27	30082A0219		HUB, <b>4B2500</b>	2
27	30100A0204		HUB, <b>4B3000</b>	2

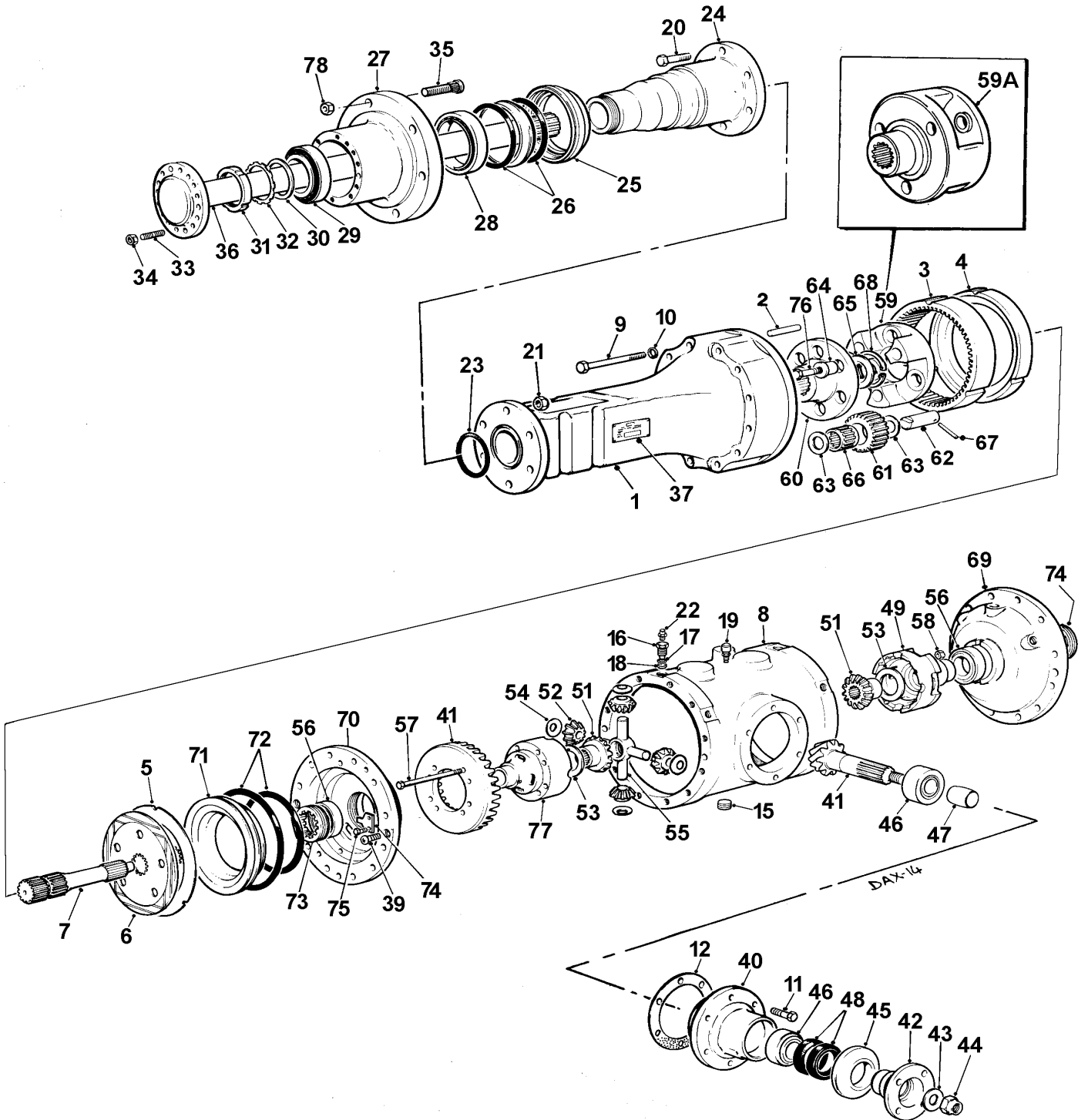

**AXLES, 350RF (with brakes)**
**2 - A - 2**

Item	Part no	Serial no	Description	Qty
28	30082A0220		BEARING, hub, inner, <b>4B2500</b>	2
28	30100A0228		BEARING, hub, inner, <b>4B3000</b>	2
29	30082A0221		BEARING, hub, outer	2
30	30082A0222		SPACER, hub bearing	2
31	30082A0223		NUT, locking	2
32	30082A0224		WASHER, tab	2
33	30082A0267		STUD	16
34	59S04		NUT, nylon insert, <b>4B2500</b>	16
34	30100A0229		NUT, nylon insert, <b>4B3000</b>	16
35	30082A0225		STUD, wheel	12
36	30082A0226		SHAFT, axle, <b>4B2500</b>	2
36	30100A0223		SHAFT, axle, <b>4B3000</b>	2
38	15S01A		SCREW, hammer drive <b>4B2500</b>	4
38	30101A0233		SCREW, hammer drive <b>4B3000</b>	4
39	30082A0266		SCREW, button head	4
40	30082A0228		CARTRIDGE, input pinion	1
41	30082A0270		BEVEL PINION	1
42	30082A0230		DRIVE FLANGE	1
43	30082A0231		WASHER, drive flange	1
44	30082A0232		NUT, drive flange	1
45	30082A0233		COVER, oil seal	1
46	30082A0234		BEARING, pinion, <b>4B2500</b>	2
46	30100A0232		BEARING, pinion, <b>4B3000</b>	2
47	30082A0235		SPACER, pinion bearing	1
48	30082A0236		SEAL, oil pinion	2
49	30082A0237		CASE, differential, R.H. <b>4B2500</b>	1
49	30100A0212		CASE, differential, R.H. <b>4B3000</b>	1
51	30082A0238		WHEEL, differential	2
52	30082A0240		PINION, differential	2
53	30082A0241		WASHER, thrust, diff. wheel	2
54	30082A0242		WASHER, thrust, diff. pinion	4
55	30082A0243		SPIDER, differential	1
56	30082A0244		BEARING, differential	2
57	8S04Q		BOLT	8
58	59S03		NUT, nylon insert	8
59	30082A0245		# PLANET CARRIER, <b>OBSOLETE</b> <b>Use item 59A</b>	1
59A	30082A0245		# PLANET CARRIER, assembly	1
60	30082A0246		# CARRIER, drive, <b>OBSOLETE</b> <b>Use item 59A</b>	1

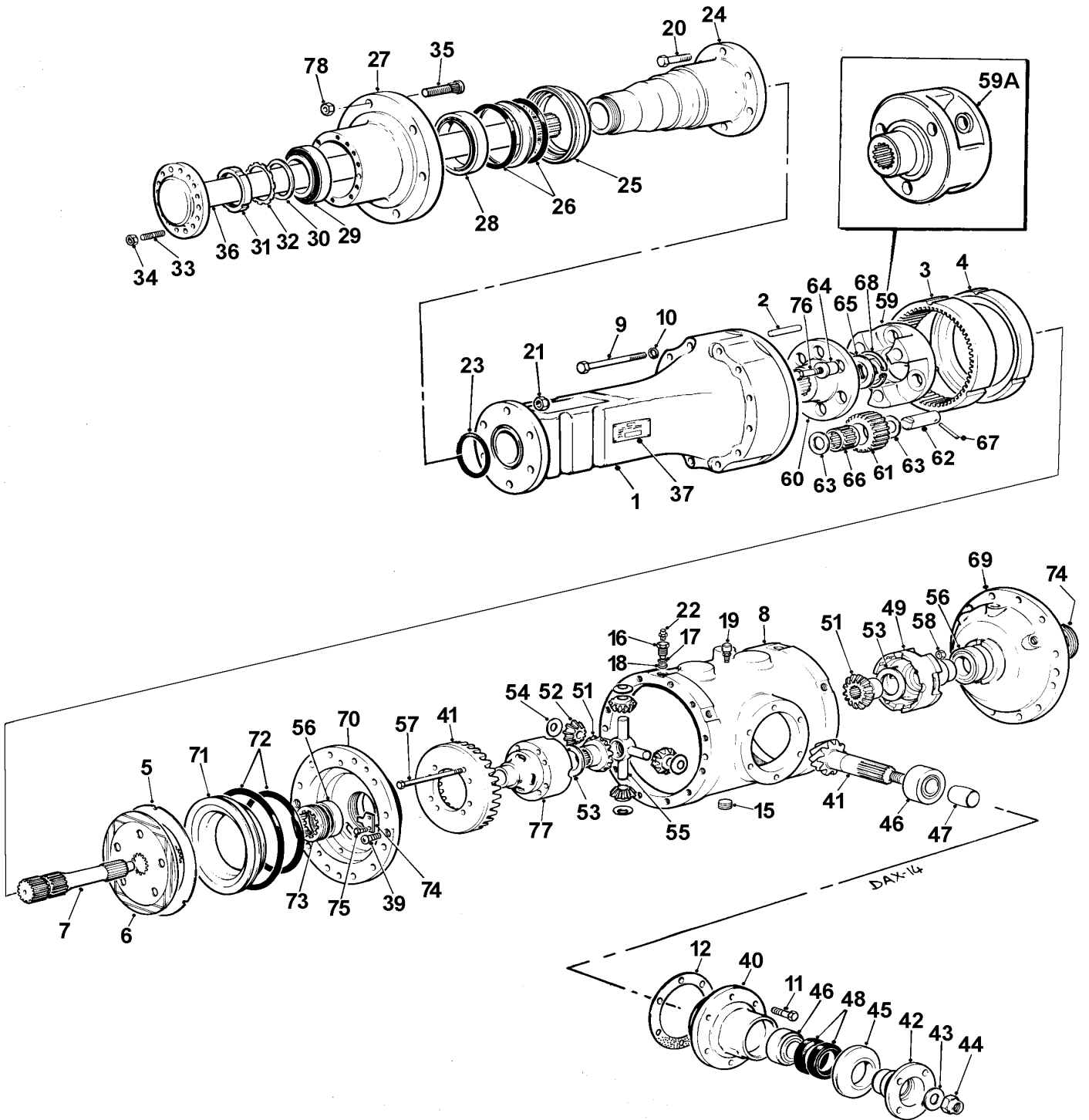

**AXLES, 350RF (with brakes)**

**2 - A - 2**

<b>Item</b>	<b>Part no</b>	<b>Serial no</b>	<b>Description</b>	<b>Qty</b>
61	30082A0247		GEAR, planet	3
62	30082A0248		PIN, planet	3
63	30082A0249		WASHER, thrust	6
64	30082A0250		# BUSH, planet carrier, <b>OBSOLETE</b> <b>Use item 59A</b>	6
65	30082A0251		SPACER, axle shaft thrust	1
66	30082A0252		ROLLER, planet cage	3
67	30082A0253		DOWEL	3
68	30082A0265		CIRCLIP	1
69	30082A0271		BRAKE CYLINDER, R.H.	1
70	30082A0272		BRAKE CYLINDER, L.H.	1
71	30082A0256		PISTON, brake, <b>4B2500</b>	2
71	30100A0210		PISTON, brake, <b>4B3000</b>	2
72	30082A0257		SEAL, oil brake piston, <b>4B2500</b>	2
72	30100A0211		SEAL, oil brake piston, <b>4B3000</b>	2
73	30082A0259		NUT, bearing adjusting	2
74	30082A0260		PLATE, locking	2
75	30082A0261		SCREW, lock plate	4
76	30082A0262		BOLT, planet carrier	6
77	30082A0263		CASE, differential, L.H., <b>4B2500</b>	1
77	30100A0212		CASE, differential, L.H., <b>4B3000</b>	1
78	.....		NUT, wheel (see page 2-W-1)	



Item	Part no	Axle serial no	Description	Qty
<i>From dumper serial no 700289</i>				
			<b>4B2500</b>	
—	30347A01		AXLE, type 360RF 14S 321	2
			<b>4B3000</b>	
—	30347A02		AXLE, type 360RF 14S 322	2
1	59S04		NUT, self-locking	16
2	30082A0267		STUD	16
3	30347A0101		SHAFT, <b>4B2500</b>	2
3	30100A0223		SHAFT, <b>4B3000</b>	2
4	30082A0223		LOCKNUT	2
5	30347A0201		WASHER, tab	2
6	30082A0222		SPACER	2
7	30082A0221		BEARING	2
8	30082A0219		HUB	2
9	.....		NUT wheel (see page 2-W-1)	
10	30082A0225		STUD, wheel	12
11	30347A0102		STUB AXLE, <b>4B2500</b>	2
11	30100A0203		STUB AXLE, <b>4B2500</b>	2
12	30082A0268		SEAL, 'O' ring	2
13	30082A0220		BEARING, hub inner	2
14	100S01		SEAL, bonded	2
15	30082A0218		SEAL, oil	2
16	30082A0217		HOUSING, oil seal	2
17	30347A0203	/ 1636443	ARM, axle	2
17	30347A0220	1636444 /	ARM, axle	2
18	8S04N		BOLT	24
19	17S05		WASHER, spring	22
21	30082A0277	/ 1636443	CARRIER, planet gears (16 splines)	2
21	30082A0285	1636444 /	CARRIER, planet gears (16 splines)	2
22	30082A0247	/ 1636443	GEAR, planet	6
22	30082A0286	1636444 /	GEAR, planet	6
23	30082A0248	/ 1636443	PIN, planet gear	6
23	30082A0287	1636444 /	PIN, planet gear	6
24	30082A0251	/ 1636443	SPACER, axle shaft	2
24	30082A0288	1636444 /	SPACER, axle shaft	2

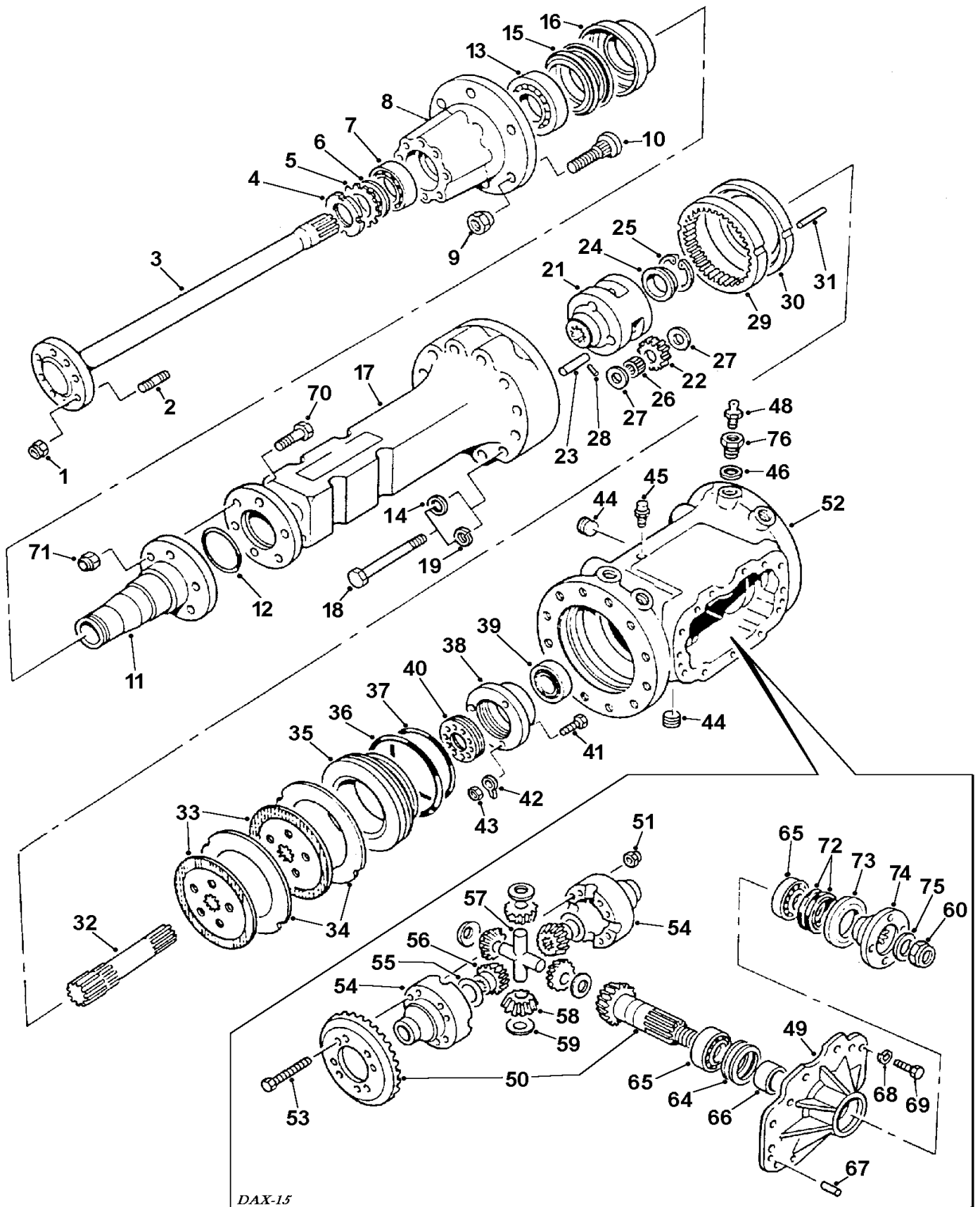



**AXLES, 360RF (with brakes)****2 - A - 3**

<b>Item</b>	<b>Part no</b>	<b>Axle serial no</b>	<b>Description</b>	<b>Qty</b>
25	30082A0265		CIRCLIP	2
26	30156A0178	/ 1636443	BEARING, needle roller, (imperial)	6
26	30082A0289	1636444 /	BEARING, needle roller, (metric)	6
27	30082A0249		WASHER, thrust	12
28	30082A0253		DOWEL	6
29	30082A0203	/ 1636443	ANNULUS	2
29	30082A0292	1636444 /	ANNULUS	2
30	V600045	/ 1636443	SPACER	1
30	30082A0293	1636444 /	SPACER	1
31	30347A0206		DOWEL	6
32	30082A0207		GEAR, sun	2
33	30082A0206		PLATE, disc	4
34	30082A0205		PLATE, brake	4
35	30347A0207		PISTON, brake	2
36	30347A0208		SEAL, 'O' ring	2
37	30347A0209		SEAL, 'O' ring	2
38	30347A0210		HOUSING, bearing	2
39	119325000		BEARING	2
40	30082A0259		NUT	2
41	11S04D		SCREW	6
42	30156A0110		PLATE, locking	2
43	59S03		NUT	6
44	30156A0127		PLUG, socket	2
45	10305A01		VALVE, breather	1
46	30156A0155		SEAL, bonded	4
48	30347A0211		VALVE, brake bleeding	1
49	30347A0212		HOUSING, pinion	1
50	30082A0270		BEVEL WHEEL & PINION	1
51	59S03		NUT, self-locking	8
52	30347A0219		CASING, axle	1
53	8S04P		BOLT	8
54	30347A0215		CASING, differential, two halves	1
55	30082A0241		WASHER, thrust, differential wheel	2
56	30082A0283		WHEEL, differential	2
57	30082A0243		SPIDER	1



**AXLES, 360RF (with brakes)****2 - A - 3**

<b>Item</b>	<b>Part no</b>	<b>Axle serial no</b>	<b>Description</b>	<b>Qty</b>
58	30082A0284		PINION, differential	4
59	30082A0242		WASHER, thrust, differential pinion	4
60	30082A0232		NUT	1
64	30082A0282		SHIM, 0.25mm	AR
64	30082A0280		SHIM, 0.30mm	AR
64	30082A0281		SHIM, 0.40mm	AR
65	30082A0234		BEARING, cup & cone	2
66	30082A0235		SPACER	1
67	30156A0112		DOWEL	2
68	17S05		WASHER, spring	13
69	11S04E		SCREW, set	13
70	8S05E		BOLT	12
71	59S04		NUT, self-locking	12
72	30082A0236		SEAL, oil	2
73	30082A0233		COVER, seal	1
74	30082A0230		FLANGE, input	1
75	30082A0231		WASHER, drive flange	1
76	30347A0218		ADAPTOR, brake pipe	4

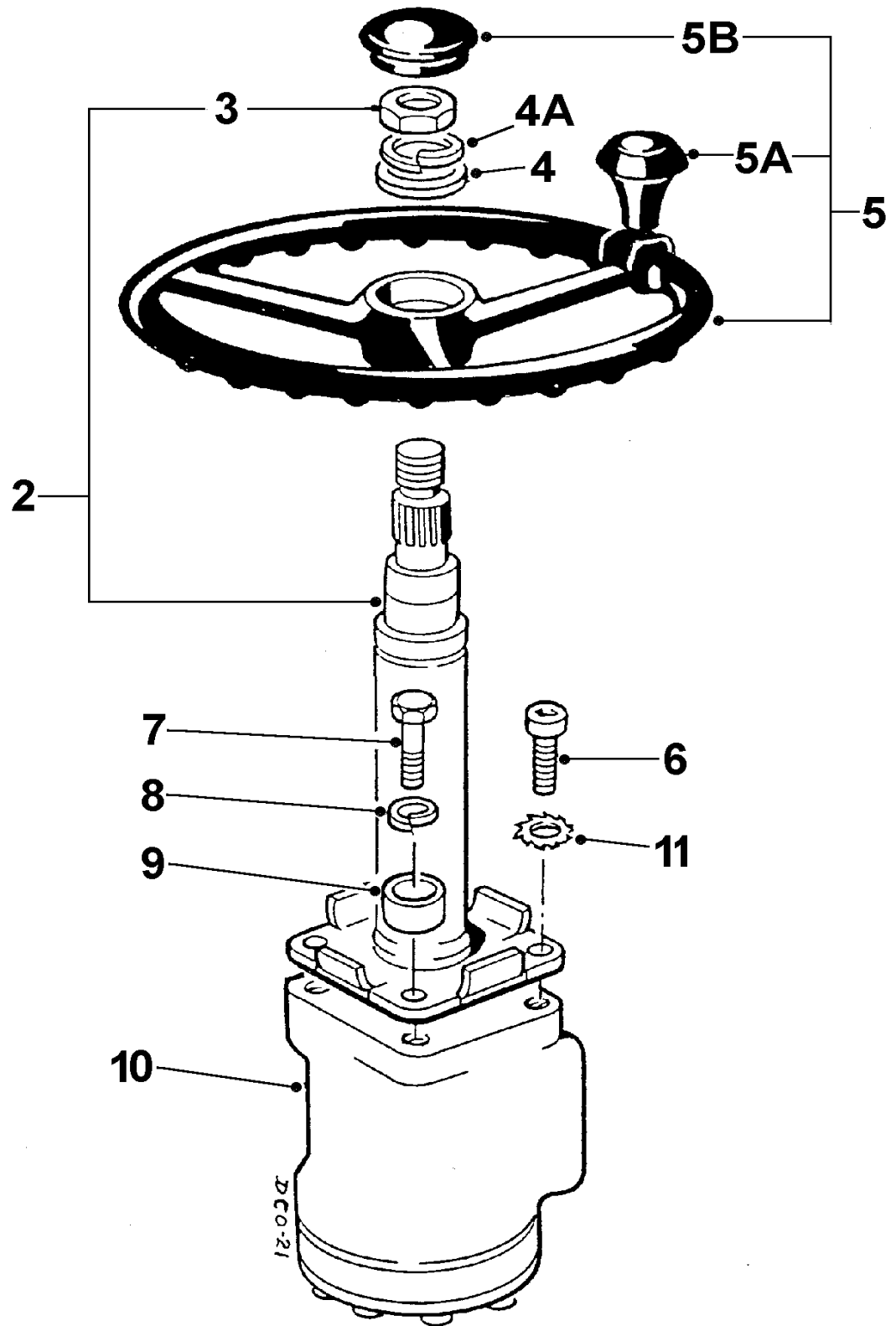

# STEERING COLUMN

2 - S - 1

Item	Part no	Serial no	Description	Qty
2	CSE1781		COLUMN, steering assembly	1
3	95S06		# NUT (5/8" UNF)	1
3	.....		# NUT (M16 x 1.5 pitch)	1
			# <b>Check thread before ordering nut</b>	
4	267S09		WASHER, flat	1
4A	17S08		WASHER, spring	1
5	40064A01		WHEEL, steering, 400mm dia <b>(OBSOLETE: use V2002350)</b>	1
5B	10314A01		CAP	1
5	V2002350		WHEEL, steering, 400mm dia	1
5B	V601232		CAP	1
.....	V601233		REDUCER, cap	1
5	V2003164		WHEEL, steering, 350mm dia , c/w knob <b>(OBSOLETE: use V2004152)</b>	1
5B	V601232		CAP	1
5	V2004152		WHEEL, steering, 350mm dia	1
5A	V600491		SPINNER, knob	1
5B	V2004153		CAP	1
6	103S04B		SCREW, socket	2
7	69S03G		BOLT	2
8	41S05		WASHER, spring	2
9	CSE182		SPACER	2
10	CSE1782		UNIT, steering, EM&S	1
.....	V602683		KIT, seals, EM&S	AR
11	67S04		WASHER, shakeproof	2

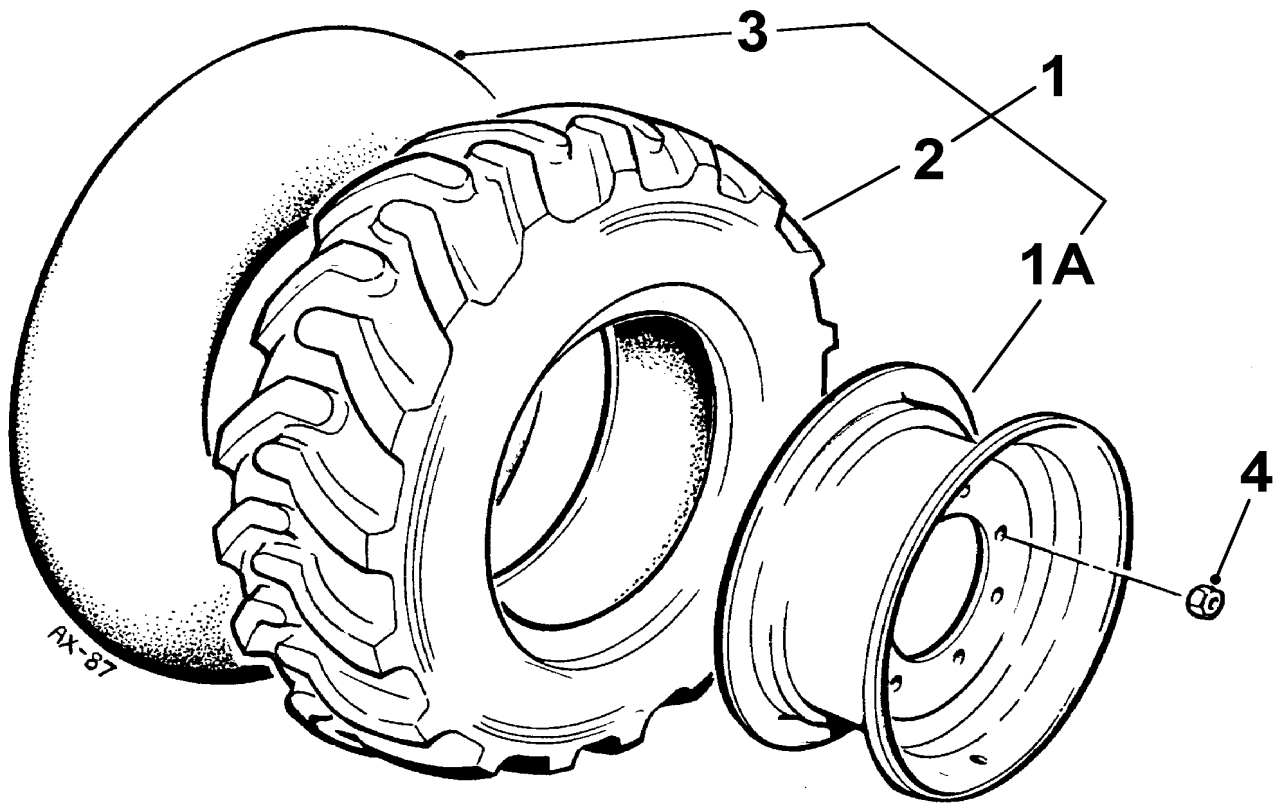

Item	Part no	Serial no	Description	Qty
<b>4B2500</b>				
1	24S67		WHEEL, assembly, L.H.	2
1	24S68		WHEEL, assembly, R.H.	2
1A	20131A05		RIM, wheel, 9 x 15	1
2	20S13		TYRE, 11.5 x 15	1
3	23S08		TUBE, 11.5 x 15	1
4	10668A02		NUT	24

<b>4B3000</b>				
1	24S86		WHEEL, assembly, L.H.	2
1	24S87		WHEEL, assembly, R.H.	2
1A	30183A01		RIM, wheel, 9 x 18	1
2	20S12		TYRE, 12.5/80 x 18	1
3	23S05		TUBE, 12.5 x 18	1
4	10668A04		NUT	24

***Section***

**3**



# ***ENGINES***

## **ENGINES**

**Petter PH2 & Lister ST3** **3 - A - 1**

---

**Lister TS3 & TR3** **3 - A - 2**

---

**SILENCERS** **3 - B - 1**

---

**FUEL TANK & PIPES** **3 - C - 1**

---

## **AIR CLEANERS**

**Lister engines** **3 - D - 1**

---

**Petter engines** **3 - D - 2**

---

**ACCELERATOR** **3 - E - 1**

---

**STOP CABLE** **3 - F - 1**

---

***< To begining of Parts***

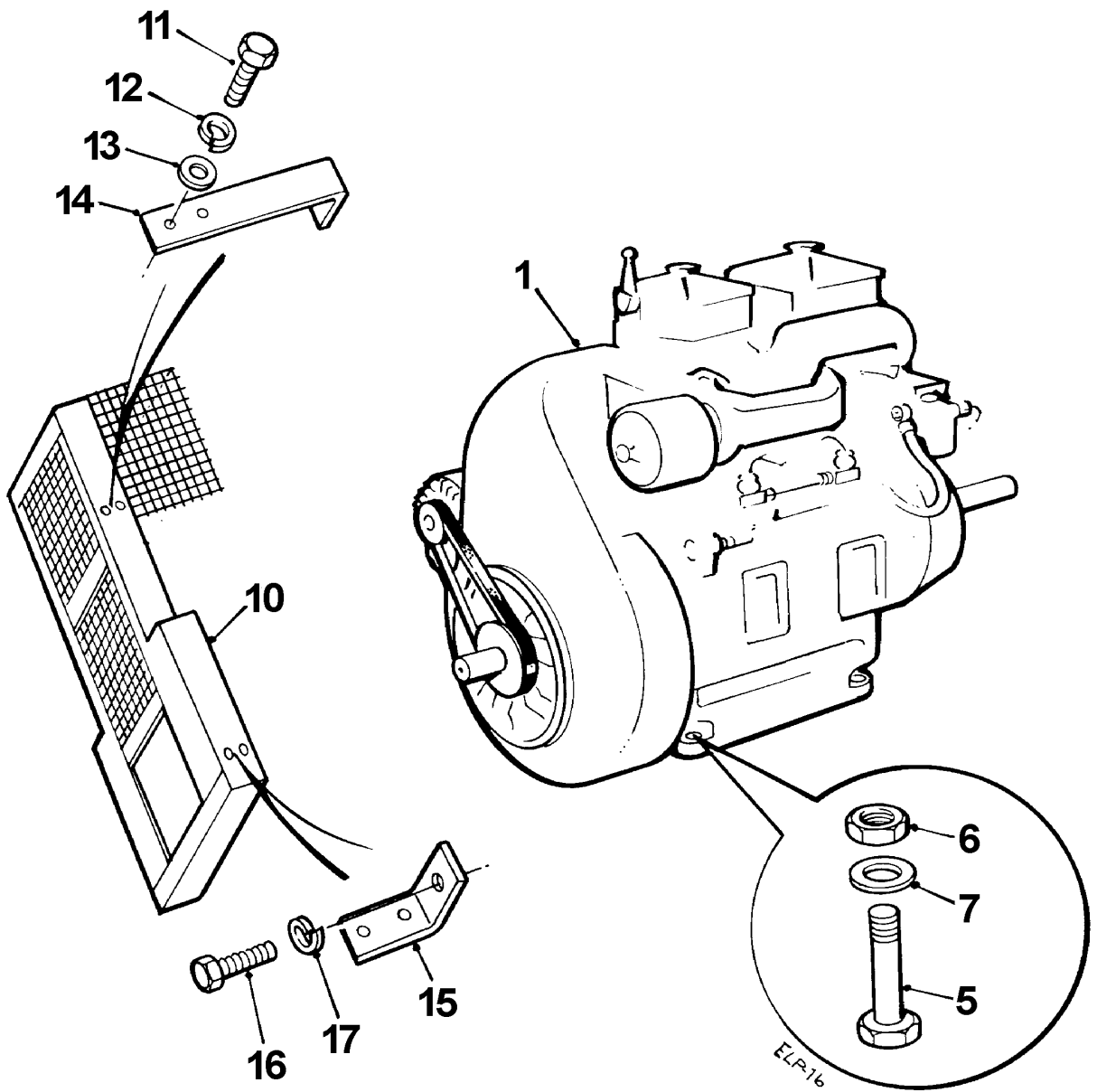
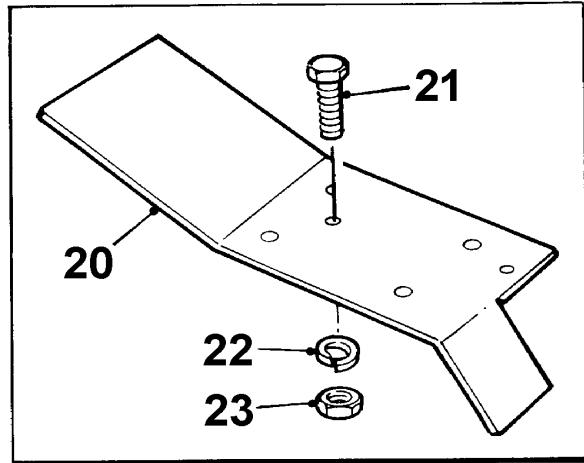

<b>Item</b>	<b>Part no</b>	<b>Serial no</b>	<b>Description</b>	<b>Qty</b>
1	20332A01		ENGINE, <b>Lister ST3</b>	1
.....	10467A01		HANDLE,engine starting, <b>ST3</b>	1
1	20329A03		ENGINE, <b>Petter PH2</b>	1
.....	C188		HANDLE, engine starting, <b>PH2</b>	1
5	6S05K		BOLT, <b>Lister engine</b>	4
5	6S05D		BOLT, <b>Petter engine</b>	4
6	132S05		NUT, self-locking	4
7	10S04		WASHER, flat	4

**Petter engine**

10	30178A02		GUARD, alternator	1
11	11S02AA		SCREW, set	6
12	17S03		WASHER, spring	6
13	267S04		WASHER, flat	6
14	10382A05		BRACKET, alternator guard	1
15	10382A06		BRACKET, alternator guard	2
16	11S1AA		SCREW, set	2
17	17S02		WASHER, spring	2

**Lister ST3 engine**

20	30178A05		GUARD, alternator	1
21	11S02B		SCREW, set	2
22	17S03		WASHER, spring	2
23	7S02		NUT	2

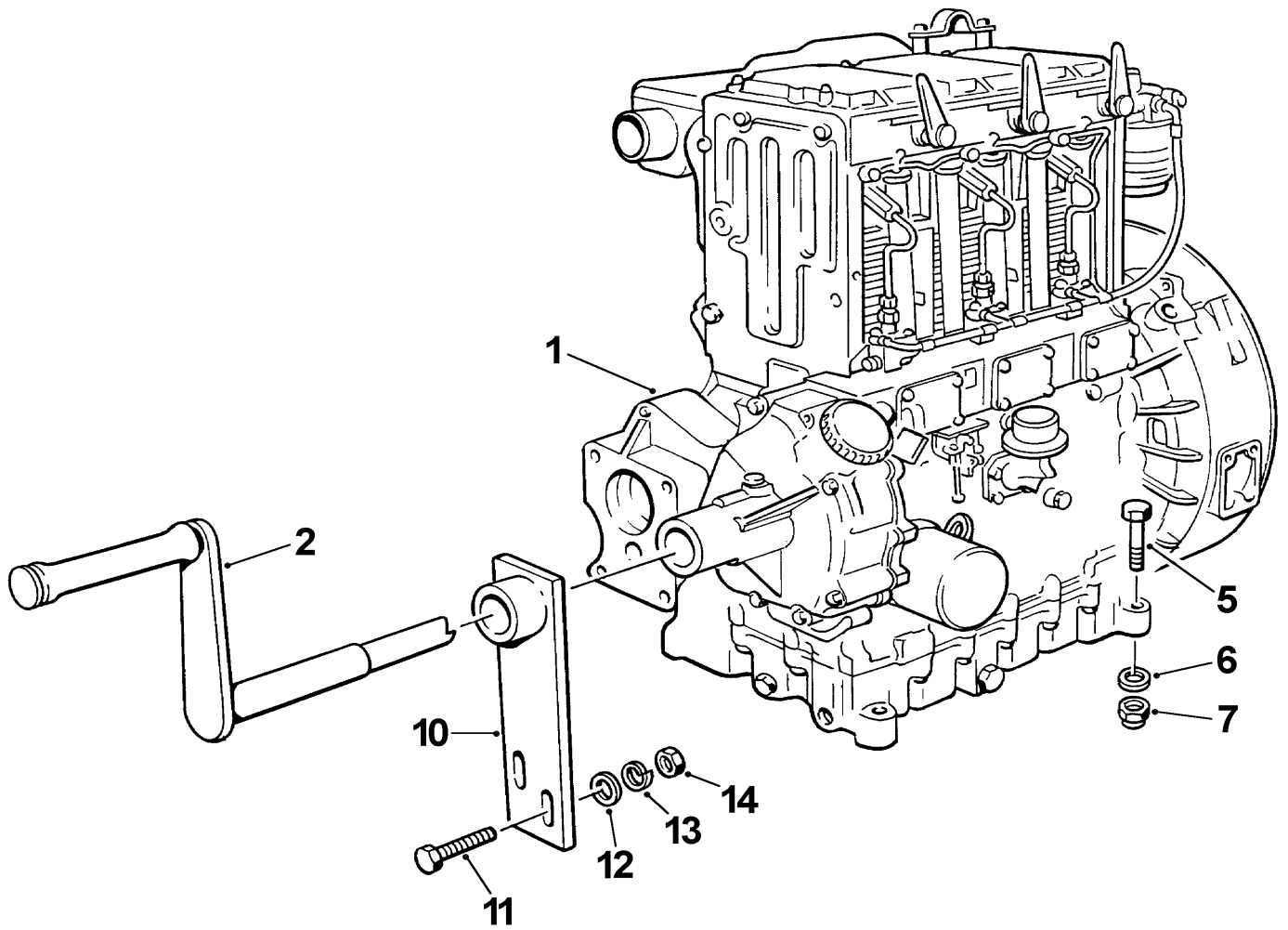

<b>Item</b>	<b>Part no</b>	<b>Serial no</b>	<b>Description</b>	<b>Qty</b>
1	20351A01		ENGINE, TS 3-07	1
2	20354A01		HANDLE, engine starting	1
5	6S05J		BOLT	4
6	10S04		WASHER, flat	4
7	107S16		NUT, self-locking	4
10	20355A01		BRACKET. Starting handle	1
11	11S04E		BOLT	2
12	267S06		WASHER, flat	2
13	17S05		WASHER, spring	2
14	7S04		NUT	2

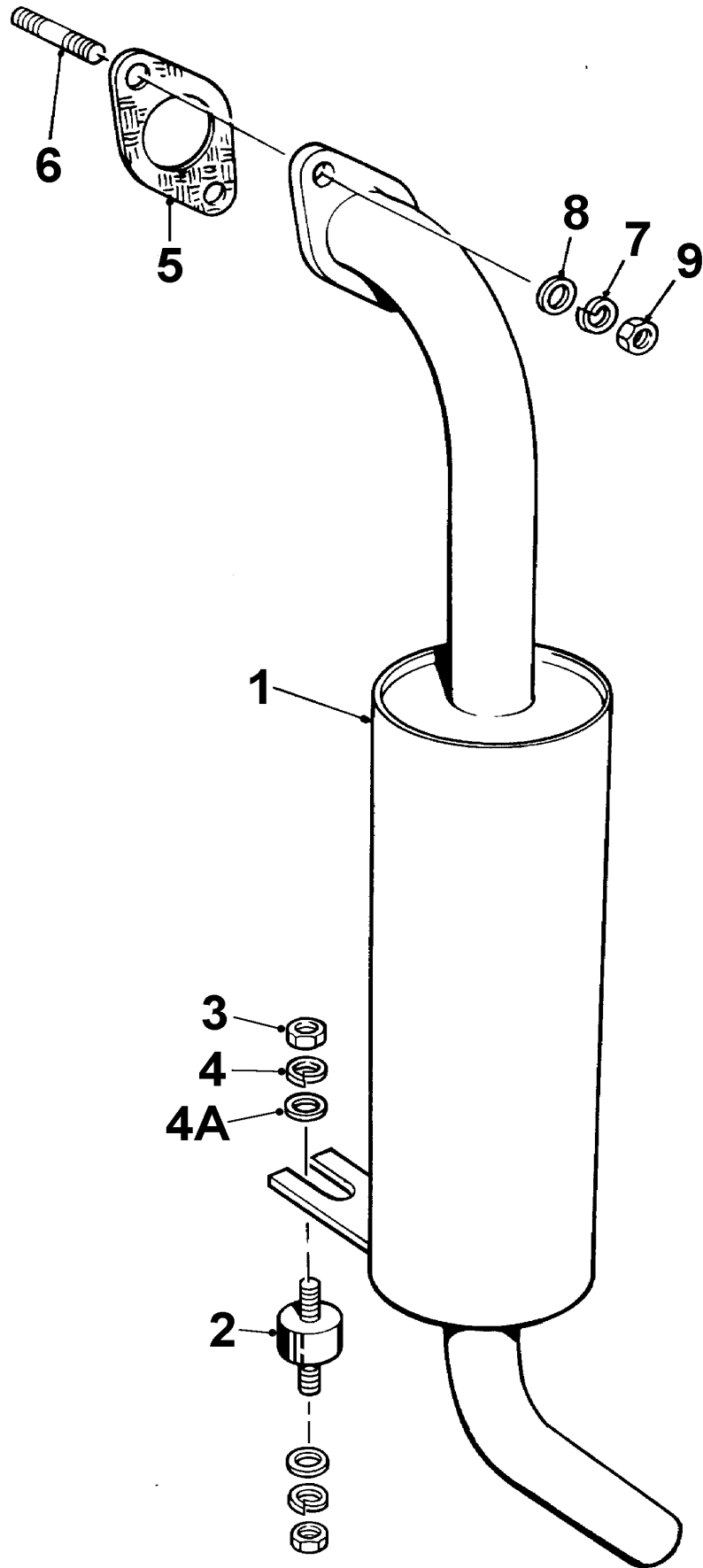

**SILENCER****3 - B - 1**

<b>Item</b>	<b>Part no</b>	<b>Serial no</b>	<b>Description</b>	<b>Qty</b>
1	30154A09		SILENCER, <b>Petter</b>	1
1	30154A12	/ 500099	SILENCER, <b>Lister ST3</b>	1
1	30154A16	500100 /	SILENCER, <b>Lister TS3</b>	1
2	10371A01		MOUNTING, rubber	1
3	7S03		NUT	2
4	17S04		WASHER, spring	2
4A	267S05		WASHER, flat	2
5	10293A02		GASKET, silencer, <b>Petter</b>	2
5	10293A03		GASKET, silencer, <b>Lister</b>	2
<b>Petter PH2</b>				
6	213S02E		BOLT, 5/16" BSF x 1"	2
7	41S04		WASHER, spring	2
<b>Lister ST3</b>				
6	6S02D		BOLT, 5/16" UNF X 1 5/8"	2
7	41S05		WASHER, spring	2
<b>Lister TS3 &amp; TR3</b>				
6	11S04C		BOLT, M10 x 25, OBSOLETE: use stud	
6	411411035		STUD, M10 X 35	2
7	17S05		WASHER, spring	2
8	267S06		WASHER, flat	2
9	7S04		NUT	2

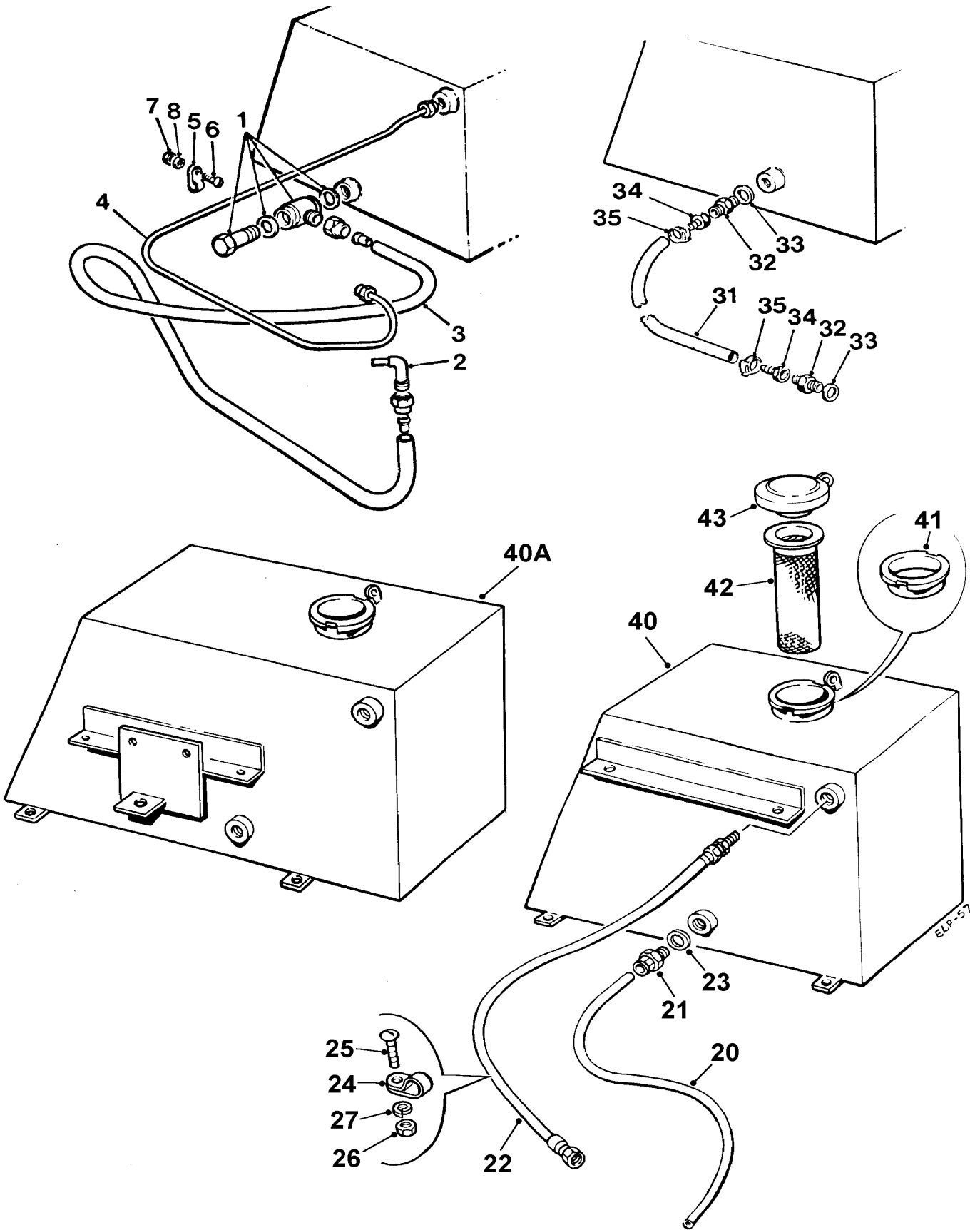

ELP-57



# FUEL TANK & PIPES

3 - C - 1

Item	Part no	Serial no	Description	Qty
<b>Lister ST3 engine</b>				1
1	117S02	/ 500099	BANJO	1
2	118S01A	/ 500099	ELBOW	1
3	29S05	/ 500099	HOSE	1
4	10576A02	/ 500099	HOSE, leak off	1
5	4S113	/ 500099	CLIP, hose	1
6	82S03C	/ 500099	SCREW	1
7	85S01	/ 500099	NUT, nylon insert	1
8	17S02	/ 500099	WASHER, spring	1
<b>Lister TS3 &amp; TR3 engines</b>				
20	29S05A	500100 /	HOSE	1
21	10315A01	500100 /	FITTING, coupling	1
22	10357A05	500100 /	HOSE, leak off	1
23	116S08	500100 /	WASHER, copper	1
24	143200900	500100 /	CLIP, hose	1
25	200S09C	500100 /	SCREW, round head	1
26	104S15	500100 /	NUT	1
27	17S02	500100 /	WASHER, spring	1
<b>Petter engine</b>				
31	29S15		HOSE (order by metre)	AR
32	122S02		FITTING, adaptor	2
33	435364		WASHER	1
34	110S01A		NOZZLE, push on	2
35	165S04		CLIP, hose	2
40	40281A05		TANK, fuel, <b>Petter engine, 4B2500</b>	1
40	40281A10		TANK, fuel, <b>Lister engine, 4B2500</b>	1
40A	40281A03		TANK, fuel, <b>4B3000</b>	1
41	10561A02		COLLAR, filler ( <i>welded to tank</i> )	1
42	10379A03		FILTER STRAINER	1
43	10378A03		CAP, tank	1

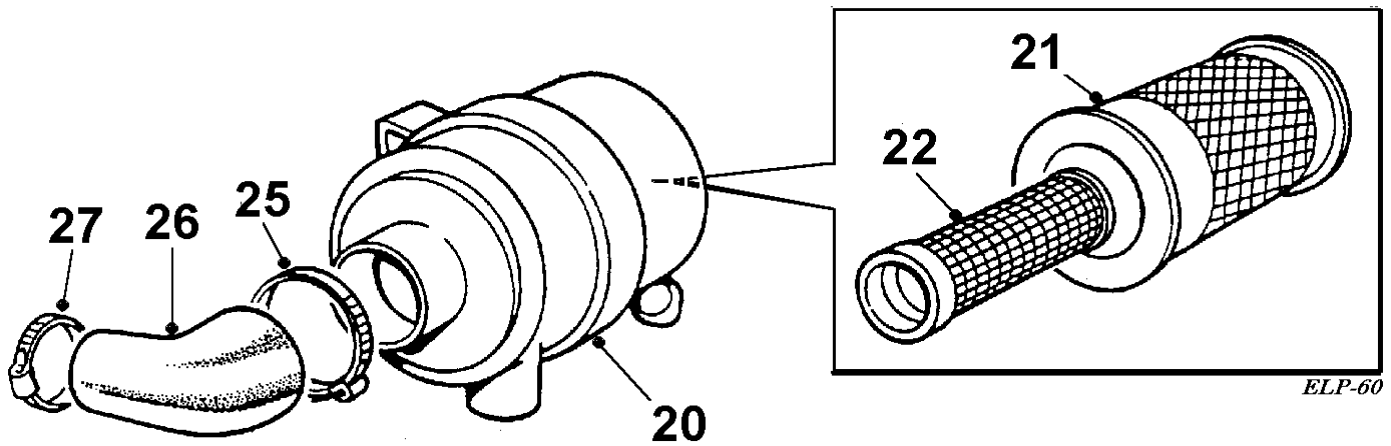
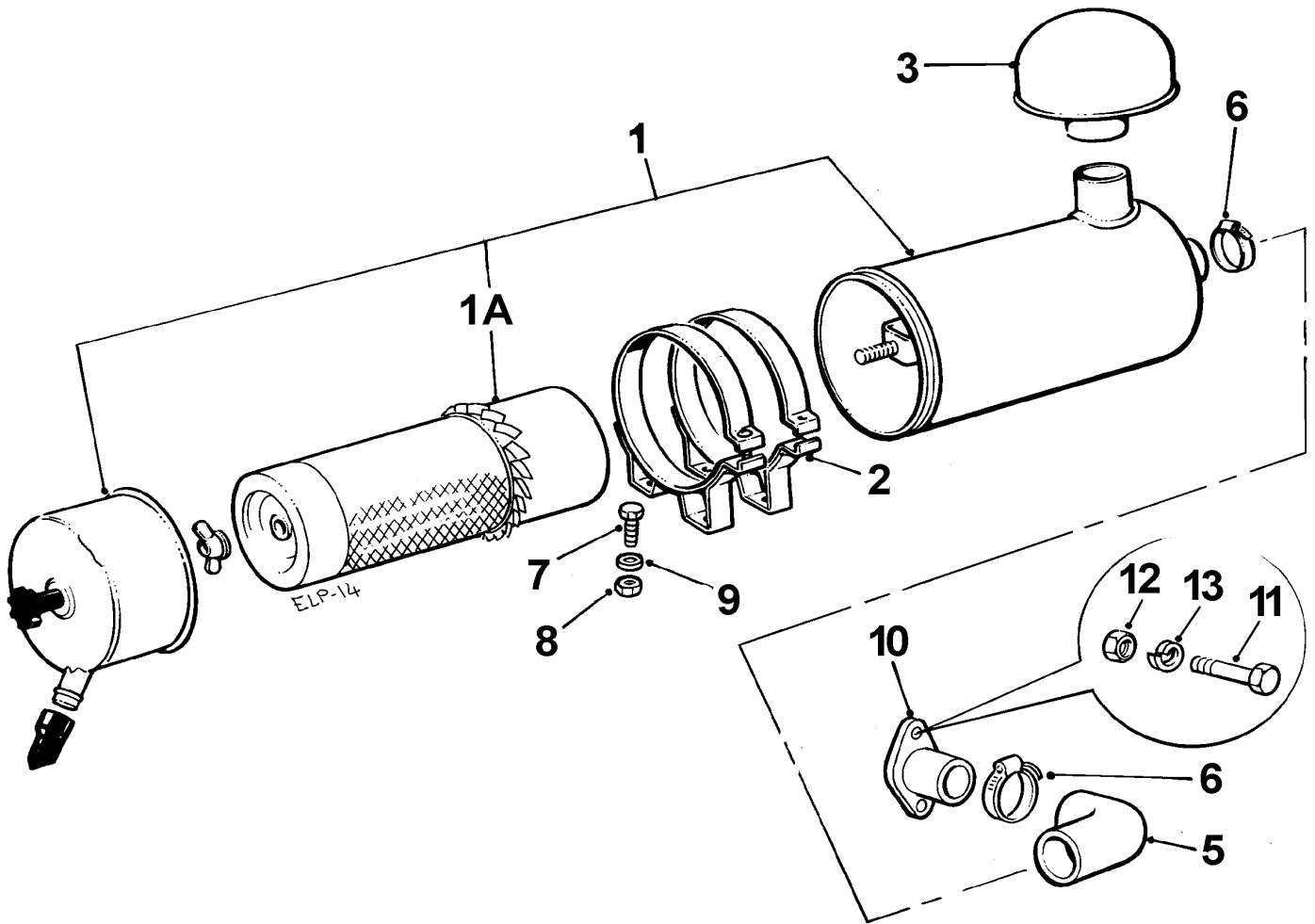

Item	Part no	Serial no	Description	Qty
<b>ST3 engine</b>				
1	10532A03		AIR CLEANER, assembly	1
1A	10532A0301		ELEMENT	1
2	10533A04		CLAMP, band	2
3	10534A04		CAP, stack	1
5	V600187		ELBOW	1
6	97S15		CLIP, jubilee	2
7	11S04C		SCREW, set	4
8	7S04		NUT	4
9	267S07		WASHER, flat	4
10	10457A03		ADAPTOR	4
11	6S03E		BOLT, 1 3/4" long	1
11	6S03H		BOLT, 2 1/2" long	1
12	9S03		NUT	2
13	41S05		WASHER, spring	2

**TS3 engine**

20	V2004182		AIR CLEANER, assembly	1
21	V2004185		ELEMENT, main	1
22	V2004186		ELEMENT, safety	1
25	97S17		CLIP, hose	1
26	V2004183		ELBOW, rubber	1
27	97S13		CLIP, hose	1

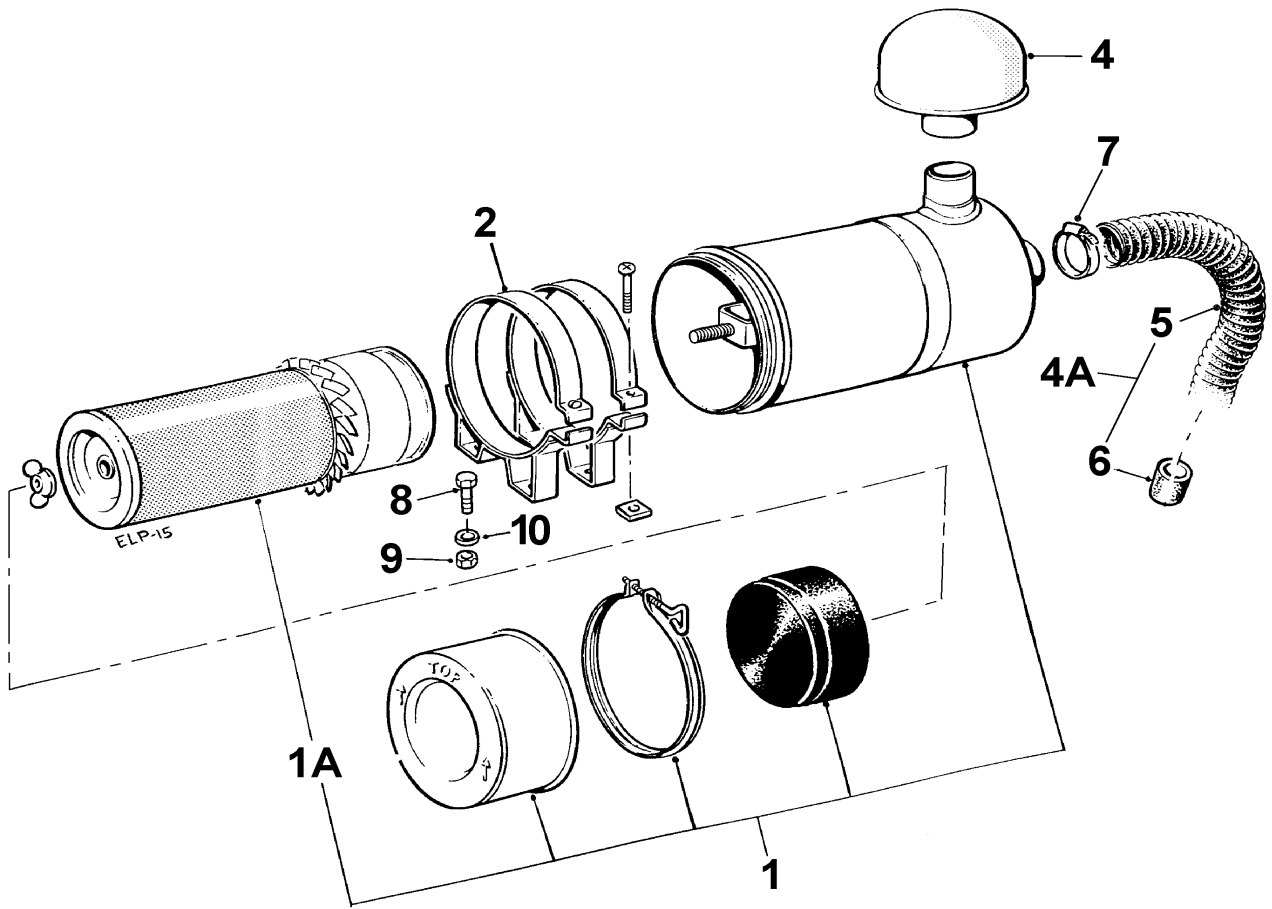

Item	Part no	Serial no	Description	Qty
<b>Petter engine</b>				
1	10532A01		AIR CLEANER, assembly	1
1A	10532A0101		ELEMENT	1
2	10533A01		CLAMP, band	2
4	10534A01		CAP, stack	1
4A	10840A03		HOSE & SLEEVE, assembly	1
5	10840A0301		HOSE	1
6	10320A06		SLEEVE	1
7	97S12		CLIP, hose	2
8	8S03A		BOLT	4
9	61S03		NUT	4
10	12S03		WASHER, flat	4

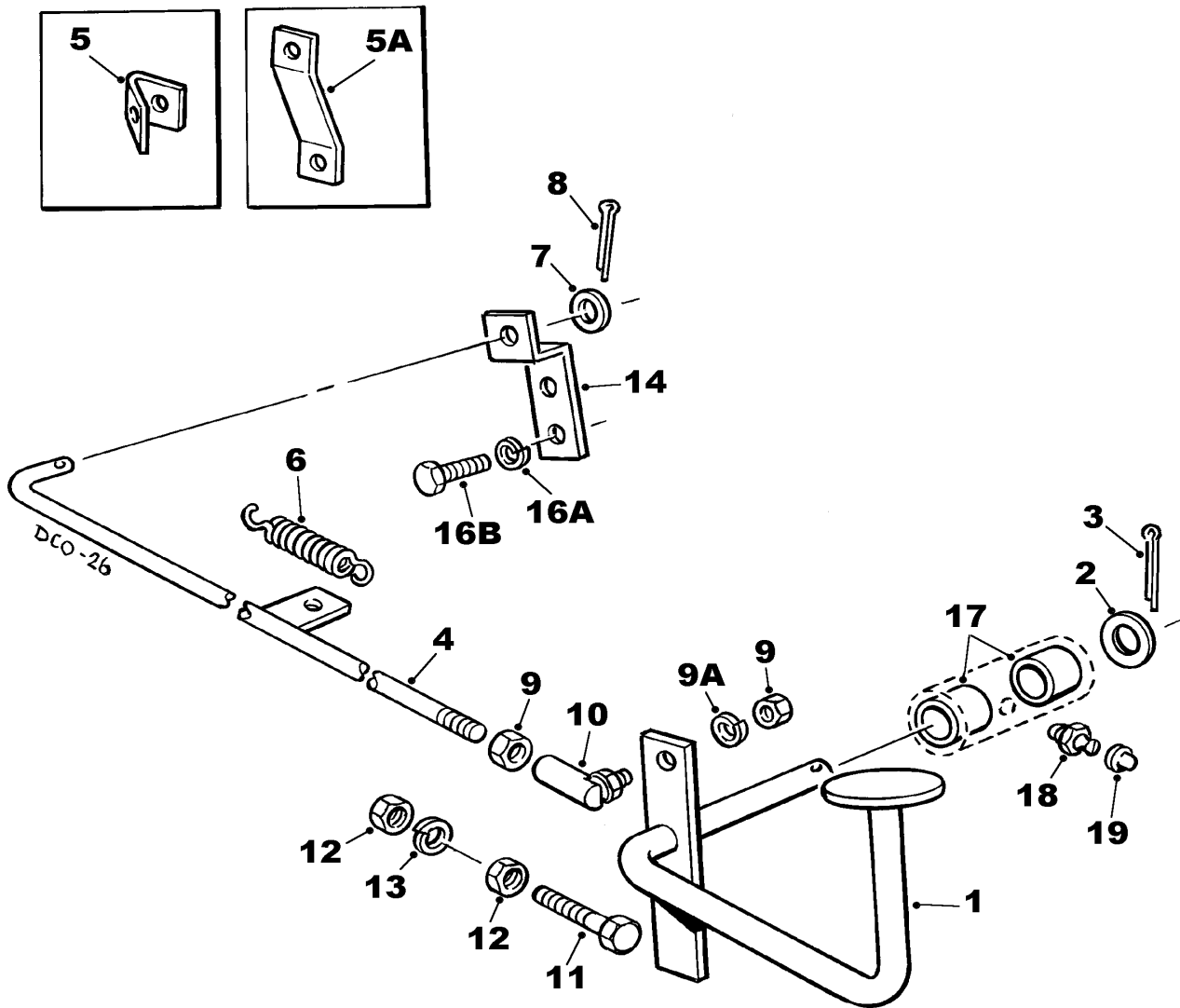

## ACCELERATOR

3 - E - 1

Item	Part no	Serial no	Description	Qty
1	20231A02		PEDAL, accelerator	1
2	10S04		WASHER, flat	1
3	44S02C		PIN, split	1
4	20166A03		ROD, accelerator, <b>Petter PH2</b>	1
4	10362A03	/ 500099	ROD, accelerator, <b>Lister ST3</b>	1
4	10362A13	500100 /	ROD, accelerator, <b>Lister TS3 &amp; TR3</b>	1
5	10360A02	/ 500099	BRACKET, spring anchor, <b>4B2500</b>	
5A	10209A04	/ 500099	BRACKET, spring anchor, <b>4B3000</b>	
6	C173D		SPRING	1
7	10S01		WASHER, flat	2
8	44S01C		PIN, split	2
9	74S02		NUT	2
9A	41S03		WASHER, spring	1
10	C160B		BALL JOINT	1
11	11S03E		SCREW, set	2
12	7S03		NUT	4
13	17S04		WASHER, spring	2
14	11031A01		LEVER, pivot	1
16A	17S03		WASHER, spring	1
16B	11S02A		SCREW, set	1
17	43S03		BUSH, pedal	2
18	131S01		NIPPLE, grease	1
19	176S01		COVER, grease nipple	1

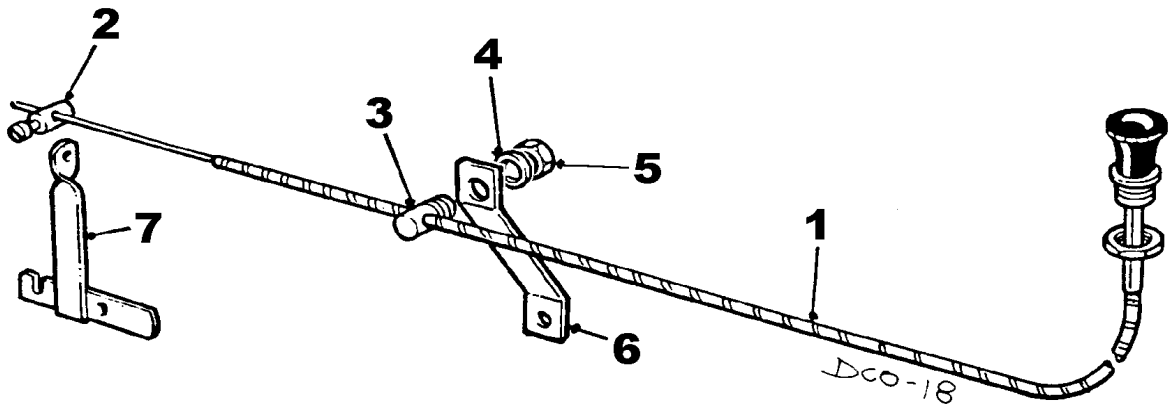
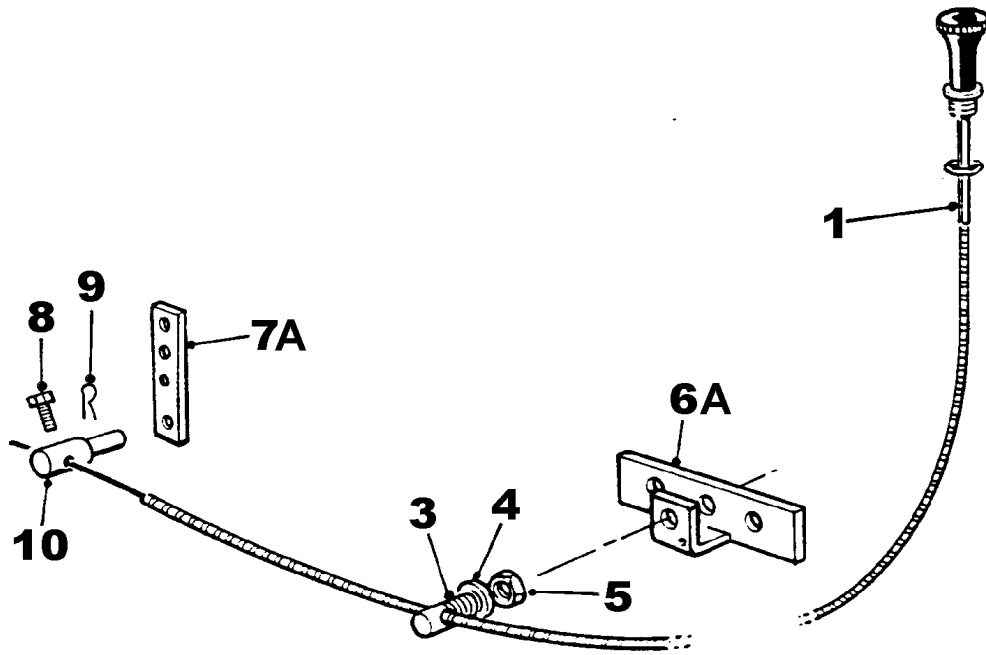



# ENGINE STOP CONTROL

3 - F - 1

Item	Part no	Serial no	Description	Qty
1	460239		CABLE, engine stop	1
2	435196		NIPPLE & SCREW	1
3	460242		SCREW CLAMP	1
4	67S04		WASHER, shakeproof	1
5	87S03		NUT, "Binx"	1
6	10209A03		BRACKET, <b>Petter</b>	1
6	10209A04	/ 500099	BRACKET, <b>Lister ST3</b>	1
6A	11029A01	500100 /	BRACKET, <b>Lister TS3 &amp; TR3</b>	1
7	10346A01	/ 500099	LEVER, pivot, <b>4B2500</b> , <b>Lister ST3</b>	1
7	10346A02	/ 500099	LEVER, pivot, <b>4B3000</b> , <b>Lister ST3</b>	1
7A	11030A01	500100 /	LEVER, pivot, <b>Lister TS2 &amp; TR2</b>	1
.....	10350A01		'P' CLIP, <i>(Not illustrated)</i>	1
8	V600192	500100 /	SCREW	1
9	V600193	500100 /	CLIP	1
10	V600194	500100 /	SWIVEL	1

***Section***

**4**

# ***TRANSMISSION***

<b>GEARBOX</b>	<b>70M</b>	<b>4 - A - 1</b>
	<b>85M</b>	<b>4 - A - 1A</b>
<hr/>		
<b>CLUTCH &amp; FLYWHEEL</b>		<b>4 - D - 1</b>
<hr/>		
<b>CLUTCH PEDAL &amp; LINKAGE</b>		<b>4 - E - 1</b>
<hr/>		
<b>PROPELLER SHAFTS</b>		<b>4 - F - 1</b>
<hr/>		
<b>TRANSFER BOX</b>	<b>Simplex chain</b>	<b>4 - F - 2</b>
	<b>Duplex chain</b>	<b>4 - F - 3</b>
<hr/>		

***< To begining of Parts***

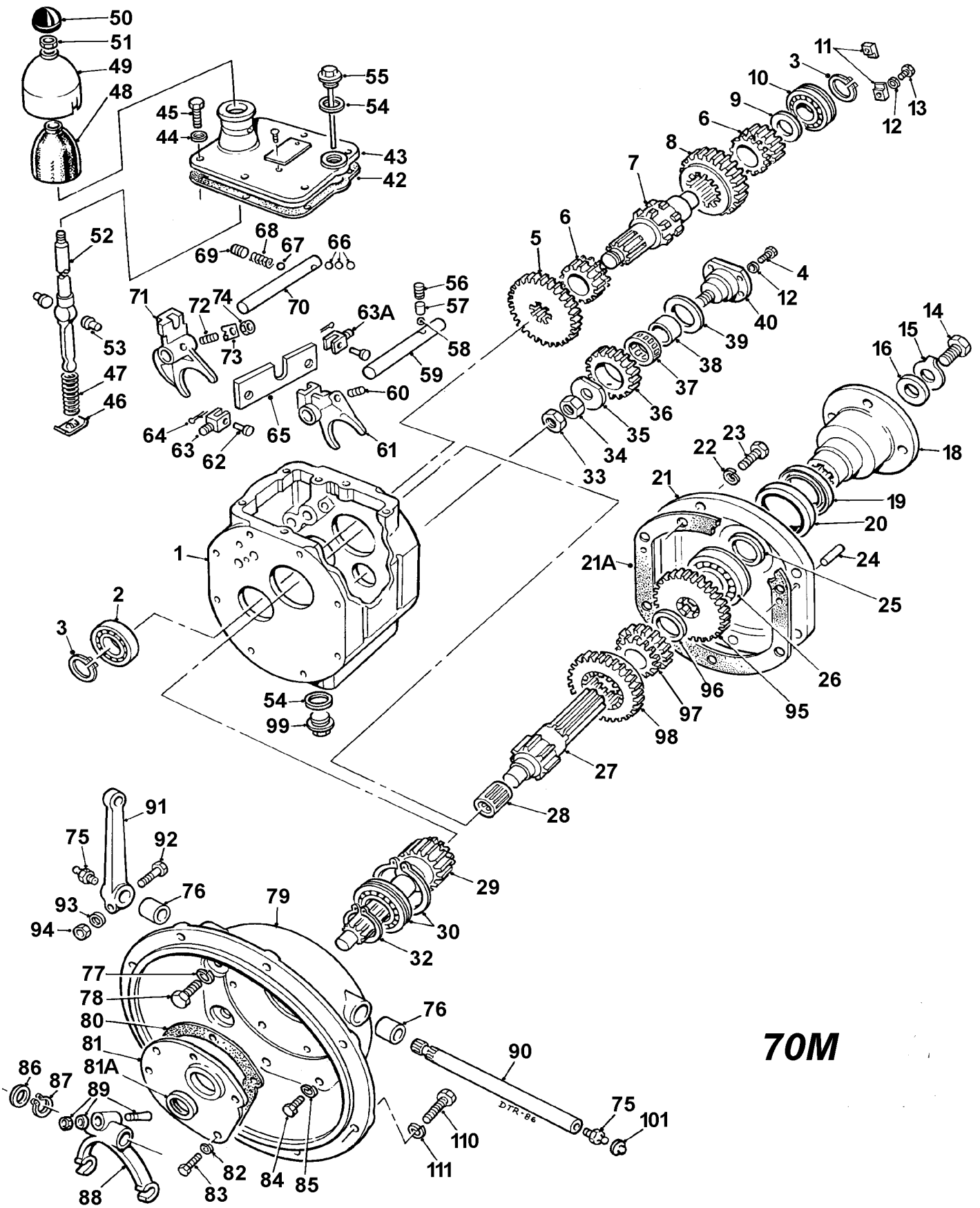

70M

Item	Part no	Serial no	Description	Qty
<i>This gearbox has been superseded by 85M gearbox</i>				
.....	30218A03	/ 600161	GEARBOX, 70M, <b>4B2500 Petter</b>	1
.....	30218A02	/ 600161	GEARBOX, 70M, <b>4B2500 Lister</b>	1
.....	30218A02	/ 600101	GEARBOX, 70M, <b>4B3000</b>	1
1	30218A0204		GEARCASE	1
2	V600195		BEARING	1
3	30218A0206		CIRCLIP	2
4	30101A0243		CIRCLIP	1
5	30101A0245		GEAR, 1st speed	1
6	30101A0219		GEAR, reverse speed	2
7	30218A0207		LAYSHAFT	1
8	30101A0224		GEAR, 2nd speed	1
9	30101A0217		SPACER	1
10	88S04E		BEARING	1
11	30190A0105		CLIP	2
12	30102A0105		WASHER	2
13	28S01D		SCREW	2
14	28S05E		SCREW	1
15	30101A0207		WASHER, tab	1
16	30101A0208		WASHER	1
17	30143A0101		WASHER, fibre	1
18	30218A0203		FLANGE, "1410" output, <b>Lister</b>	1
18	30218A0203		FLANGE, output, <b>Petter</b>	1
19	30101A0265		SHIELD, dust	1
20	30097A0132		SEAL, oil	1
21	30101A0262		COVER, end	1
21A	.....		GASKET	1
22	10389A01		WASHER, spring	6
23	11S04C		SCREW, set	6
24	30218A0208		DOWEL	2
25	30218A0209		SPACER	1
26	88S06E		BEARING	1
26A	30101A0209		RING, snap	1
27	30218A0210		MAINSHAFT	1
28	30218A0211		BEARING, needle	1
29	30218A0212		SHAFT, input	1
30	30218A0213		BEARING, assembly	1
31	.....		RING, snap ( <i>order assembly</i> )	1
32	30218A0214		CIRCLIP	1

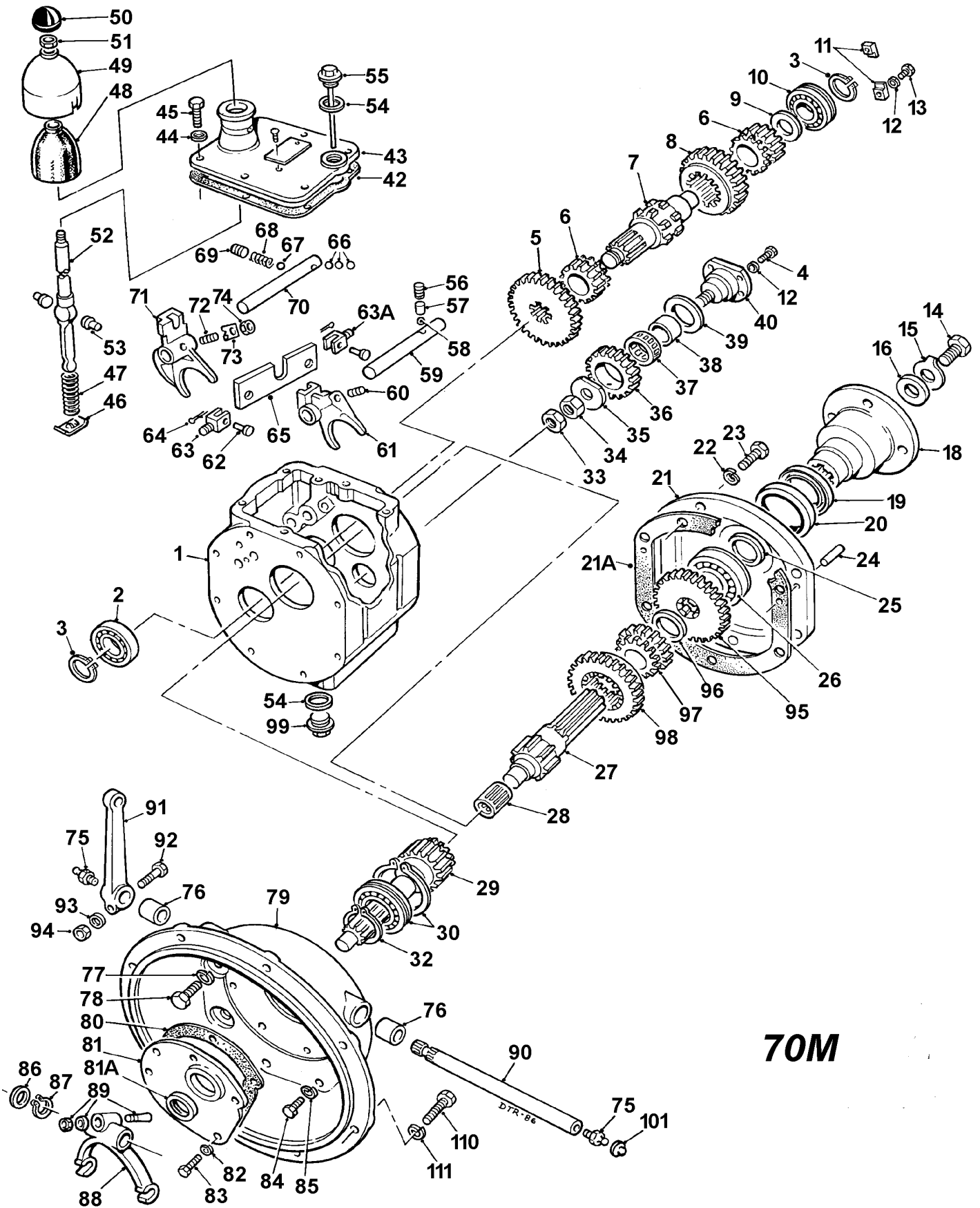

**70M**

# GEARBOX, 70M

4 - A - 1

Item	Part no	Serial no	Description	Qty
33	30218A0215		NUT, locking	1
34	30218A0216		NUT	1
35	30218A0217		WASHER, idler	1
36	30218A0218		PINION, reverse	1
37	30218A0219		BEARING, needle	1
38	30218A0220		RING, inner	1
39	30218A0221		WASHER, thrust	1
40	30218A0222		SHAFT, idler	1
41	28S01C		SCREW	4
42	30101A0250		GASKET	1
43	30101A0235		COVER, top	1
44	17S03		WASHER, spring	6
45	11S02A		SCREW, set	6
46	30101A0206		PLATE, retaining	1
47	30101A0205		SPRING	1
48	30101A0204		COVER, rubber	1
49	30101A0203		COVER, protective	1
50	30101A0201		KNOB	1
51	95S03		NUT	1
52	20210A04		LEVER, gear, <b>Petter</b>	1
52	20210A03		LEVER, gear, <b>Lister</b>	1
53	30101A0234		PAD, gear lever	2
54	30218A0231		WASHER, fibre ( <i>OBSOLETE: use 100S04</i> )	1
54	100S04		SEAL, bonded	2
55	30218A0223		DIPSTICK, 93mm rod	1
56	30097A0185		SPRING	2
57	30218A0224		SPACER	1
58	30097A0199		BALL, detent	2
59	30218A0225		SHAFT, selector, 2nd & 3rd speeds	1
60	30218A0226		SCREW, grub	1
61	30218A0227		FORK, selector, 2nd & 3rd speeds	1
62	30101A0228		PIN, clevis	2
63	30101A0229		CLEVIS, threaded	1
63A	30218A0228		CLEVIS, threaded	1
63A	30101A0270		CLEVIS, <i>not</i> threaded	1
64	44S01C		PIN, split	2
65	30101A0230		PLATE, interlock	1
66	30218A0229		BALL	3
67	30097A0199		BALL, detent	2
68	30097A0185		SPRING	2

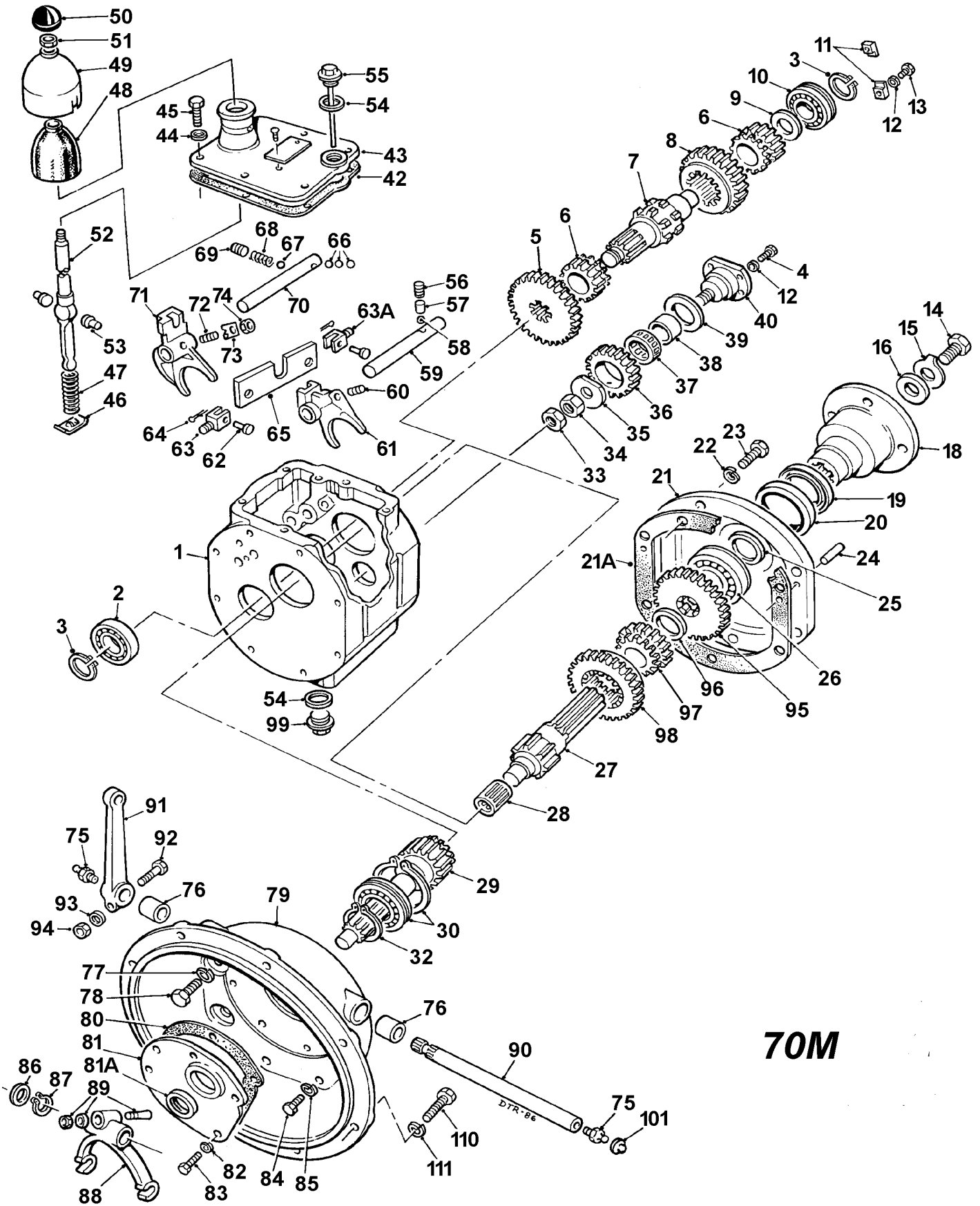



**GEARBOX, 70M****4 - A - 1**

<b>Item</b>	<b>Part no</b>	<b>Serial no</b>	<b>Description</b>	<b>Qty</b>
69	30218A0230		SCREW, grub	1
70	30218A0231		SHAFT, selector, 1st & reverse	1
71	30218A0232		FORK, selector, 1st & reverse	1
72	30218A0233		SCREW, grub	1
73	30218A0234		WASHER, locking	1
74	61S03		NUT	1
75	131S06		NIPPLE, grease	2
76	30097A0114		BUSH	2
77	17S05		WASHER, spring	16
78	11S04D		SCREW, set	6
79	30218A0237		HOUSING, clutch	1
80	30218A0238		GASKET, front cover	1
81	30218A0239		COVER, front, assembly	1
81A	30218A0245		SEAL, oil	1
82	30097A0102		WASHER, nylon	6
83	11S02A		SCREW, set	6
84	11S03D		SCREW, set	2
85	17S04		WASHER, spring	2
86	30097A0133		WASHER	1
87	30101A0256		CIRCLIP	1
88	30097A0110		FORK, clutch	1
89	30097A0111		PIN, NUT & WASHER assembly	1
90	30097A0117		SHAFT, clutch	1
91	30097A0109		LEVER, clutch	1
92	6S01C		BOLT	1
93	67S01		WASHER, shakeproof	1
94	9S01		NUT	1
95	30101A0211		GEAR, output	1
96	30101A0212		SPACER	1
97	30101A0225		GEAR, 2nd speed	1
98	30218A0241		GEAR, 1st. speed	1
99	30097A0163		PLUG, oil drain	1
101	176S01		CAP, grease nipple	2
110	.....		SCREW, set	12
111	.....		WASHER, spring	12



Item	Part no	Serial no	Description	Qty
-	30346A01	600162 / 600102 /	GEARBOX, 85M2S322 <b>4B2500</b> GEARBOX, 85M2S322 <b>4B3000</b>	
1	30346A0101		GEARCASE	1
2	88S04		BEARING	1
5	30346A0102		GEAR, 1st. speed	1
6	30346A0103		GEAR, reverse	2
7	30346A0104		SHAFT, lay	1
8	30346A0105		GEAR, 2nd. speed	1
9	30346A0106		SPACER	1
10	30346A0116		BEARING	1
11	30346A0107		CLIP, bearing retainer	2
12	67S01		WASHER, flat	2
13	28S01D		SCREW	2
14	28S05E		SCREW	2
15	30101A0207		WASHER, tab	1
16	30101A0208		WASHER	1
18	30101A0203		FLANGE, output, <b>Petter</b>	1
18	30218A0203		FLANGE, "1410" output, <b>Lister</b>	1
19	30101A0265		SHIELD, dust	1
20	89S02		SEAL, oil	1
21	30218A0246		END COVER	1
21A	30097A0158		GASKET, casing to end cover	1
22	17S05		WASHER, spring	6
23	8S04A		SCREW, set	6
24	30097A0101		DOWEL	2
25	30218A0209		SPACER	1
26	88S06E		BEARING	1
26A	30101A0209		RING, snap	1
27	30346A0108	/ 2414596	MAINSHAFT, ( <i>imperial</i> )	1
27	30346A0124	2414597 /	# MAINSHAFT, ( <i>metric</i> )	1
28	<b>30218A0211</b>	/ 2414596	BEARING, needle roller, ( <i>Imperial</i> )	1
28	V602760	2414597 /	BUSH, ( <i>option to roller bearing</i> )	1
28	30082A0289	2414597 /	# BEARING, needle roller, ( <i>metric</i> )	1

**Note:** Imperial needle roller bearing **30218A0211** is obsolete.

Two alternative solutions are available to customers, they are .....

**1** For gearboxes manufactured before serial number 2414597; a kit that includes a metric needle roller bearing is available under part number 30346A0119. (This kit # contains items 27, 28 and 29.)

**2** To facilitate those customers who find it uneconomical to replace both mainshaft and input shaft, a phosphorous bronze bush has been produced under part number V602760. However, those specifying the replacement bush must accept that it is not as durable as the original needle roller bearing and service life cannot be guaranteed.

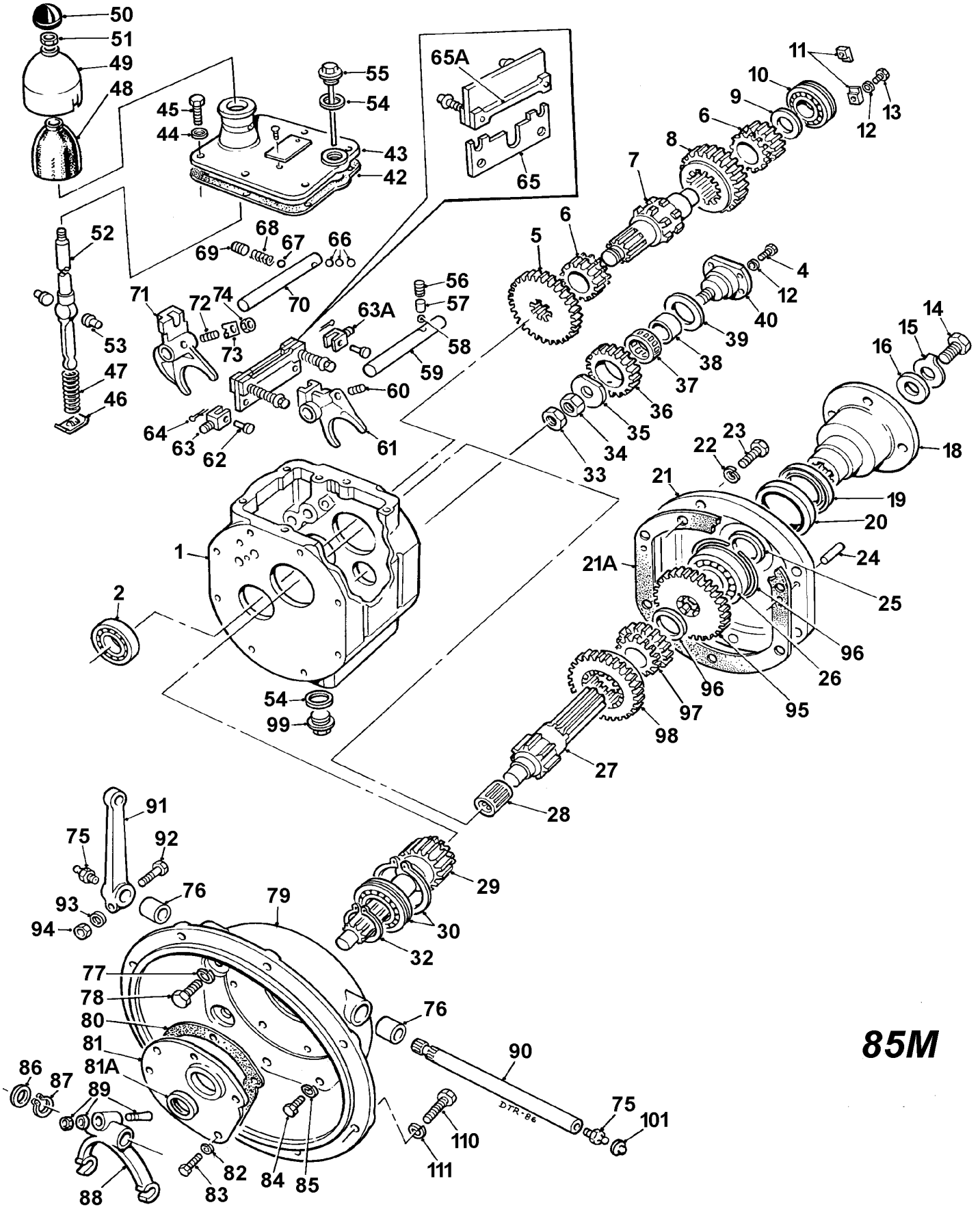

## GEARBOX, 85M

4 - A - 1A

Item	Part no	Serial no	Description	Qty
29	30346A0109	/ 2414596	SHAFT, input, ( <i>imperial</i> )	1
29	30346A0123	2414597 /	# SHAFT, input, ( <i>metric</i> )	1
30	30218A0213		BEARING, c\w snap ring,	1
32	30218A0214		CIRCLIP	1
33	95S05		NUT, locking	1
34	9S04		NUT	1
35	30218A0217		WASHER, idler	1
36	30346A0110		PINION, reverse	1
37	30218A0219		BEARING, needle	1
38	30218A0220		RING, inner	1
39	30218A0221		WASHER, thrust	1
40	30218A0222		SHAFT, idler	1
41	28S01C		SCREW	4
42	30101A0250		GASKET	1
43	30101A0235		COVER, top	1
44	17S03		WASHER, spring	6
45	11S02A		SCREW, set	6
46	30101A0206		PLATE, retaining	1
47	30101A0205		SPRING	1
48	30101A0204		COVER, rubber	1
49	30101A0203		COVER, protective	1
50	30101A0201		KNOB	1
51	95S03		NUT	1
52	20210A04		LEVER, gear, <b>Petter</b>	1
52	20210A03		LEVER, gear, <b>Lister TS3</b>	1
53	30101A0234		PAD, gear lever	2
54	100S04		SEAL, bonded	2
55	30218A0223		DIPSTICK	1
56	30097A0185		SPRING	2
57	30218A0224		SPACER	1
58	30097A0199		BALL, detent	2
59	30218A0225		SHAFT, selector, 2nd & 3rd speeds	1
60	30218A0226		SCREW, grub	1
61	30218A0227		FORK, selector, 2nd & 3rd speeds	1
62	30101A0228		PIN, clevis	2
63	30101A0229		CLEVIS, threaded	1
63A	30101A0270		CLEVIS, <i>not</i> threaded	1
64	44S01C		PIN, split	2
65	30101A0269		PLATE, interlock	1
65A	30101A0272		SPRUNG INTERLOCK c/w tool	1

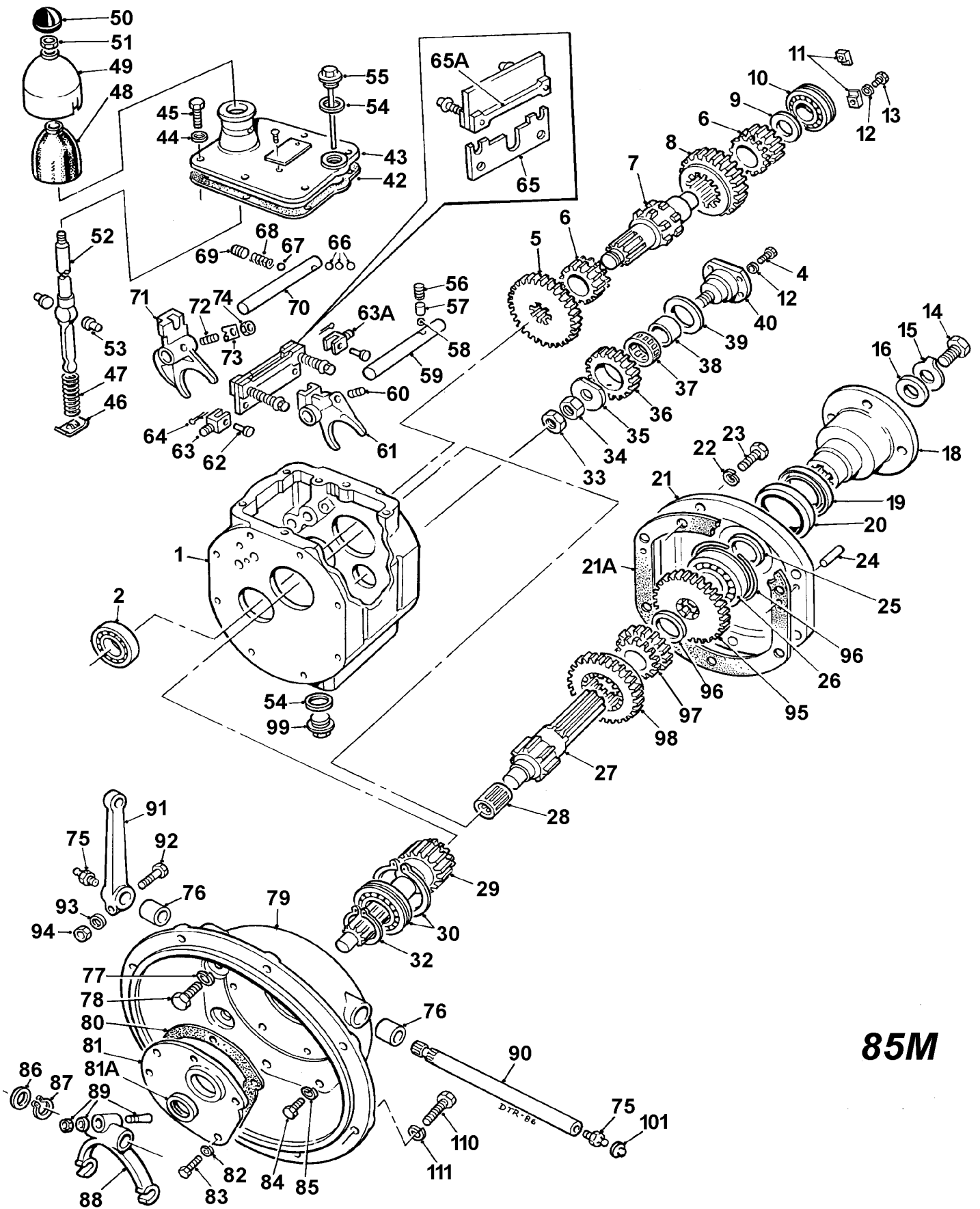

85M

**GEARBOX, 85M****4 - A - 1A**

<b>Item</b>	<b>Part no</b>	<b>Serial no</b>	<b>Description</b>	<b>Qty</b>
66	30218A0229		BALL	3
67	30097A0199		BALL, detent	2
68	30097A0185		SPRING	2
69	30218A0230		SCREW, grub	1
70	30218A0231		SHAFT, selector, 1st & reverse	1
71	30218A0232		FORK, selector, 1st & reverse	1
72	30218A0233		SCREW, grub	1
73	30218A0234		WASHER, locking	1
74	61S03		NUT	1
75	131S06		NIPPLE, grease	2
76	30097A0114		BUSH	2
77	17S05		WASHER, spring	10
.....	30312A0206		WASHER, 'Nyltite'	2
78	11S04D		SCREW, set	6
79	30218A0237		HOUSING, clutch	1
80	30218A0238		GASKET	1
81	30218A0239		COVER, front	1
81A	30218A0245		SEAL, oil	1
82	30097A0102		WASHER, nylon	6
83	11S02A		SCREW, set	6
84	11S03D		SCREW, set	2
85	17S04		WASHER, spring	2
86	30097A0133		WASHER	1
87	30101A0256		CIRCLIP	1
88	30097A0110		FORK, clutch	1
89	30097A0111		PIN, NUT & WASHER assembly	1
90	30097A0117		SHAFT, clutch	1
91	30097A0109		LEVER, clutch	1
92	6S01C		BOLT	1
93	67S01		WASHER, shakeproof	1
94	9S01		NUT	1
95	30346A0111		GEAR, output	1
96	30346A0115		SPACER	1
97	30101A0225		GEAR, 2nd speed	1
98	30346A0113		GEAR, 1st. speed	1
99	30097A0163		PLUG, oil drain	1
101	176S01		CAP, grease nipple	2
110	66S03A		SCREW, set	8
111	41S05		WASHER, spring	8

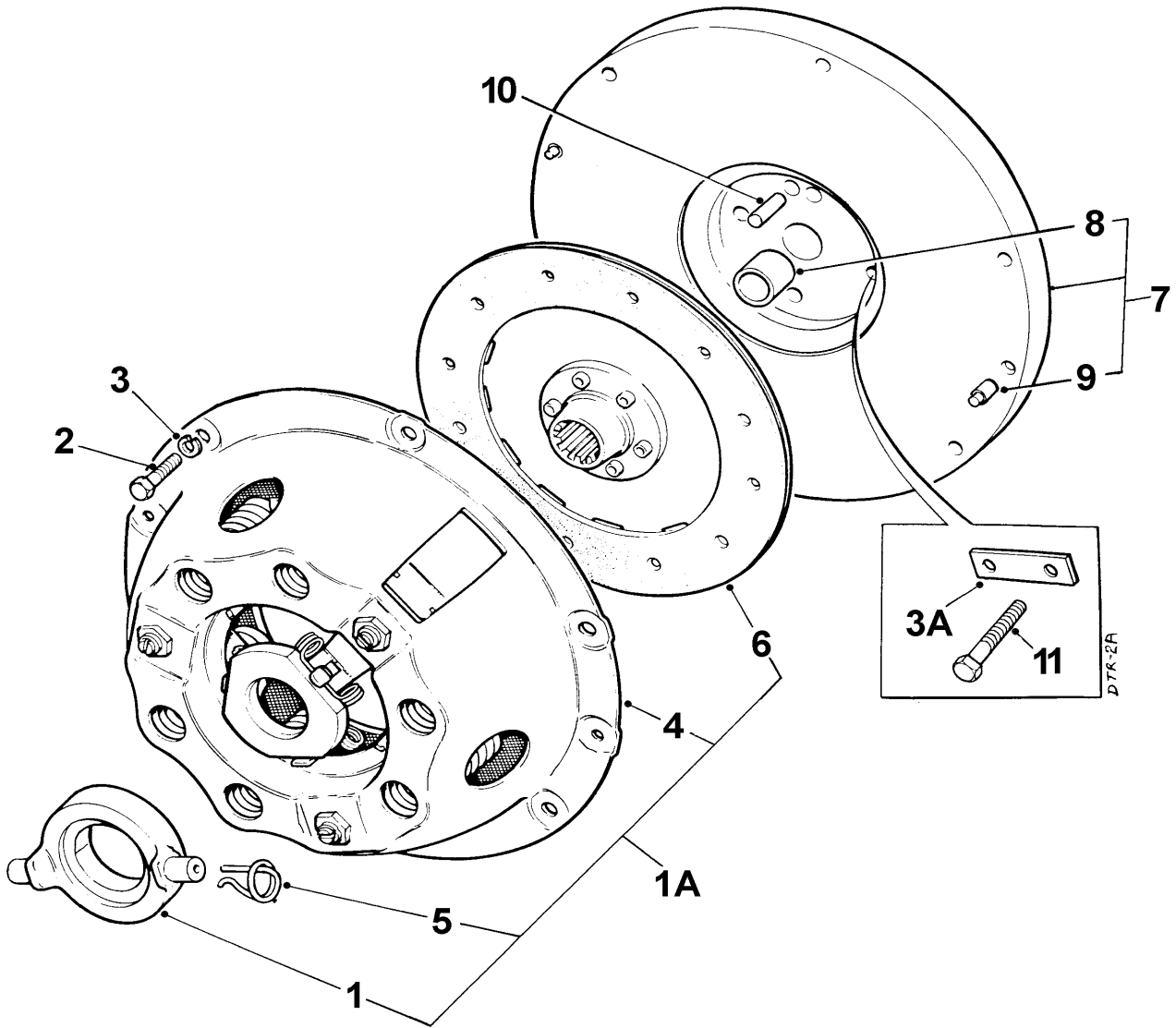



## CLUTCH &amp; FLYWHEEL

4 - D - 1

Item	Part no	Serial no	Description	Qty
1A	10948A03		# KIT, clutch, 9" (comprises of items marked #)	1
1	10579A01		# BEARING, clutch release	1
2	28S02D		SCREW, set	6
3	41S04		WASHER, spring	6
3A	10531A02		WASHER, tab, 70mm long, <b>Lister</b>	1
3A	10531A03		WASHER, tab, 60mm long, <b>Lister</b>	1
3A	10531A03		WASHER, tab, <b>Petter</b>	2
4	10597A02		# COVER	1
5	10579A0101		# SPRING, retaining	2
6	10598A03		# PLATE, driven	1
7	10580A01		FLYWHEEL, assy. (c/w items 8 & 9)	1
8	10580A0101		BUSH	1
9	10580A0102		DOWEL	1
10	C321		DOWEL	1
11	6S02B		BOLT, <b>Lister ST2</b>	4
11	1S02C		BOLT, <b>Petter</b>	4
11	8S03B		BOLT, <b>Lister TS3</b>	4

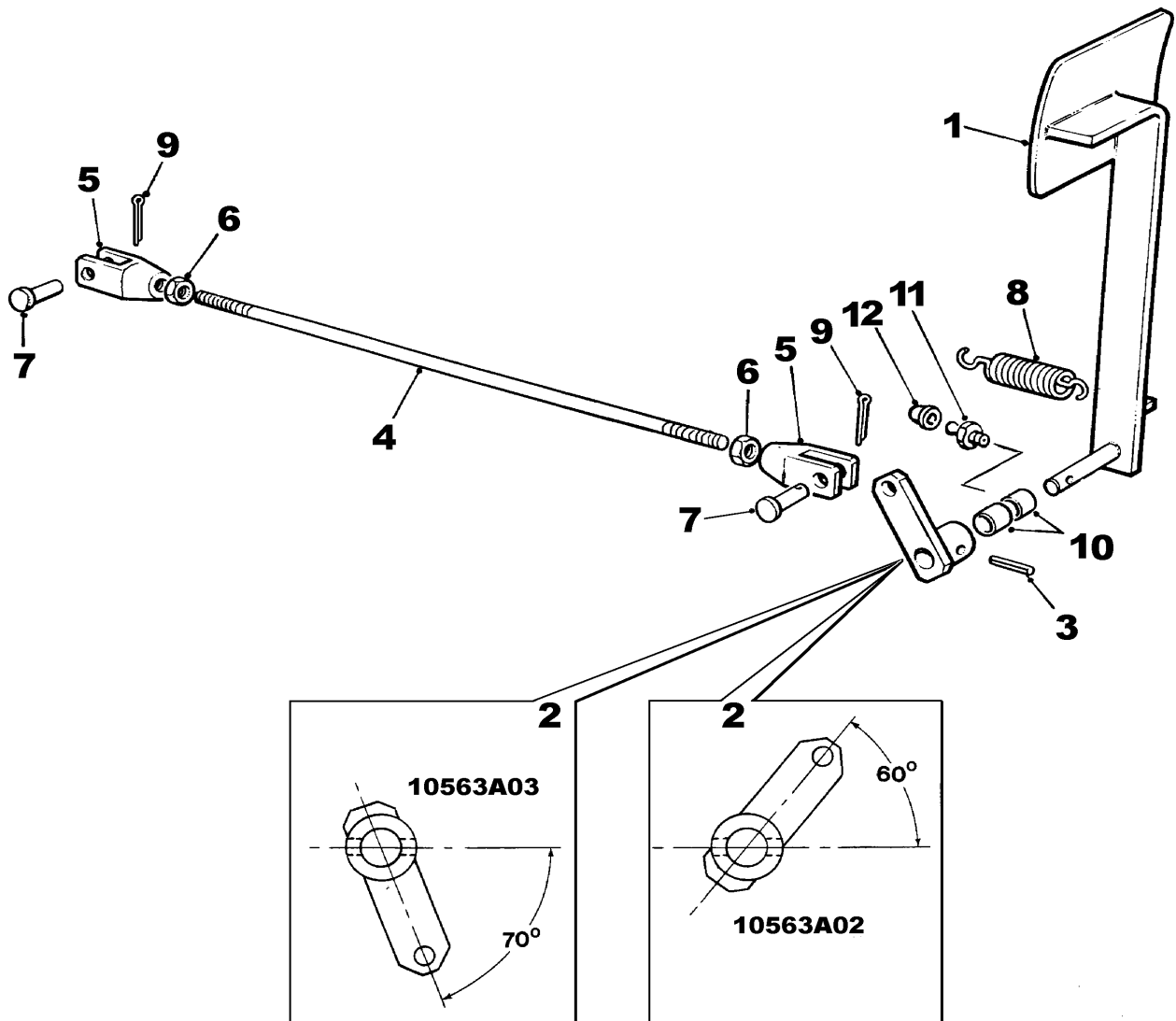

**CLUTCH PEDAL & LINKAGE****4 - E - 1**

<b>Item</b>	<b>Part no</b>	<b>Serial no</b>	<b>Description</b>	<b>Qty</b>
1	20096A05		PEDAL, clutch	1
2	10563A02		LEVER, clutch, Lister	1
2	10563A03		LEVER, clutch, Petter	1
3	54S07M		PIN, roll	1
4	40SC24		ROD (3/8" UNF X 620 long)	1
4	38SC58		ROD (3/8" BSF X 470 long)	1
4	38SC50		ROD (3/8" BSF X 425 long)	1
5	C174J		CLEVIS (3/8" UNF)	2
5	C174A		CLEVIS (3/8" BSF)	2
6	95S03		NUT, locking (3/8" UNF)	2
6	2S04		NUT, locking (3/8" BSF)	2
7	10650A17		PIN, clevis	2
8	C173B		SPRING	1
9	44S02C		PIN, split	2
10	43S02		BUSH	2
11	131S01		NIPPLE, grease	1
12	176S01		CAP, grease nipple	1

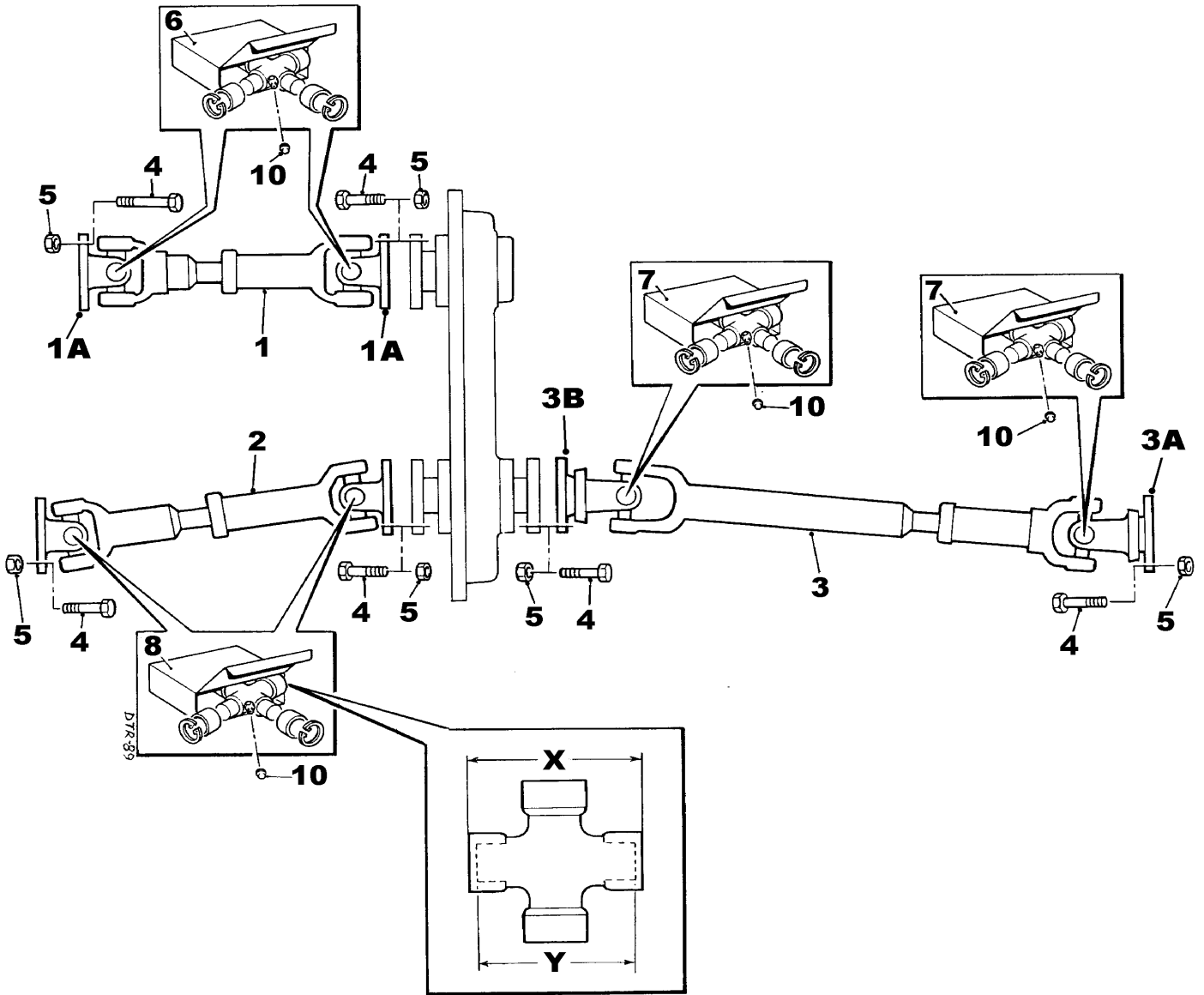

# PROPELLER SHAFTS

4 - F - 1

Item	Part no	Serial no	Description	Qty
<b>Machines with Petter PH2 engines</b>				
1	10342A02		PROPSHAFT, gearbox to trans/box	1
<b>Machines with Lister TS3 &amp; ST3 engines</b>				
1	40297A01		PROPSHAFT, gearbox to trans/box	1
1A	V602298		YOKE, standard	2
2	40114A03		PROPSHAFT, to rear axle. <b>4B2500</b>	1
2	40114A04		PROPSHAFT, to rear axle. <b>4B3000</b>	1
3	40077A03		PROPSHAFT, to front axle. <b>4B2500</b>	1
3A	V600478		YOKE, standard	1
3B	V602302		YOKE, wide angle	1
3	40077A04		PROPSHAFT, to front axle. <b>4B3000</b>	1
3A	V600478		YOKE, standard	1
3B	V602302		YOKE, wide angle	1
4	ESE214		BOLT	24
5	107S15		NUT, self locking	24
6	10307A01		KIT, U.J. repair	AR
7	10307A01		KIT, U.J. repair	AR
<b>WARNING:</b> <i>The propshafts have been manufactured with two different types of U.J. To ensure that the correct U.J. is ordered check the dimensions given below...</i>				
8	10307A01		KIT, U.J. repair 'X' 106mm overall 'Y' 100mm without caps	AR
8	10568A01		KIT, U.J. repair 'X' 82mm overall 'Y' 76mm without caps	AR
10	176S01		CAP, grease nipple	9

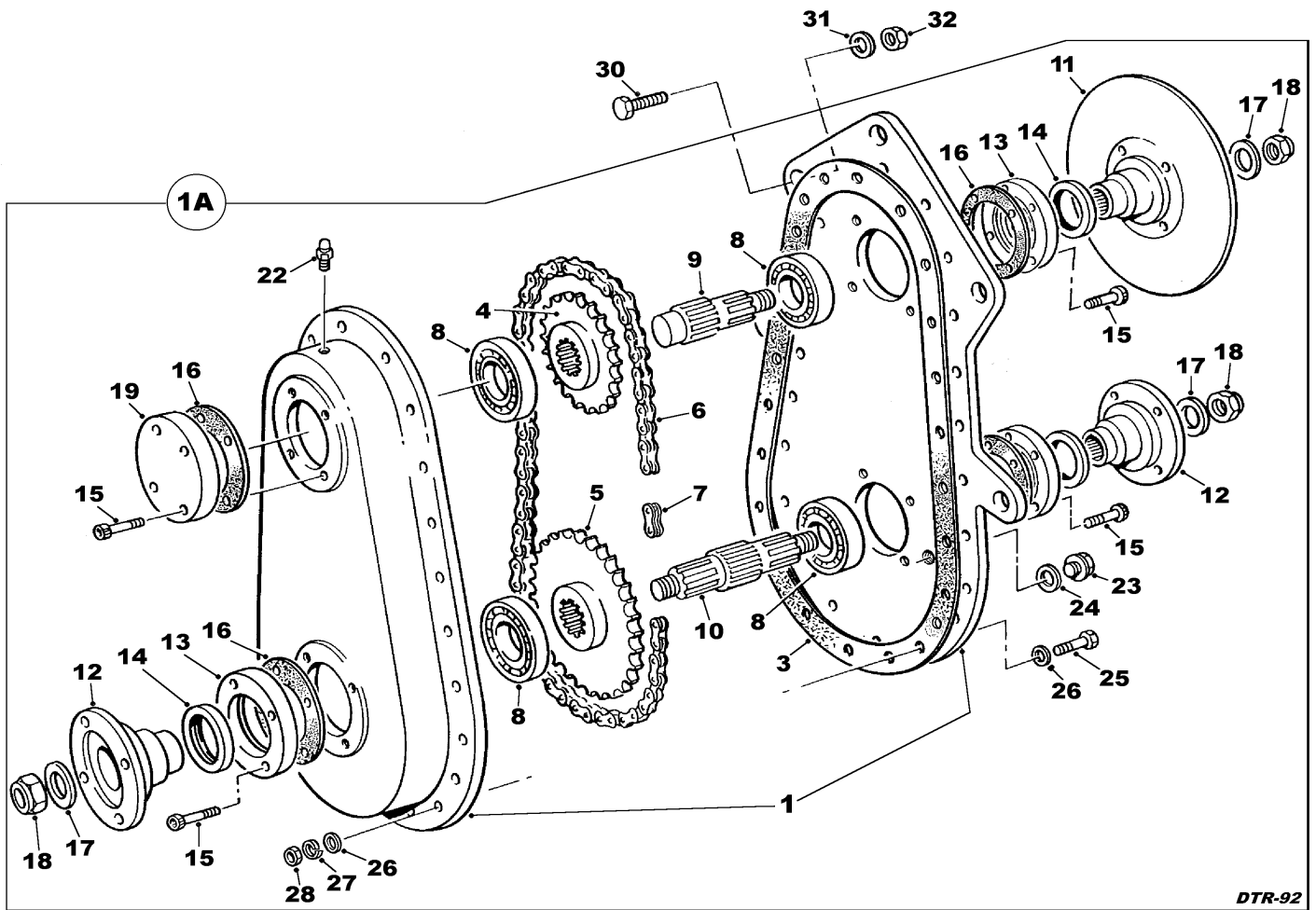

# TRANSFER BOX, Simplex chain

4 - F - 2

Item	Part no	Serial no	Description	Qty
<p><b>NOTE 1:</b> Before ordering parts, please ascertain whether the transfer gearbox has Simplex or Duplex chain(s). For Simplex chain see list below. For Duplex chains, see page 4-F-3</p> <p><b>NOTE 2:</b> Although parts for the Simplex units are still available, we strongly recommend that should one require overhauling then a new Duplex unit (40054A10) be fitted instead. <b>See Service Bulletin SB11</b></p>				
1A	40054A06	/ 1984	# TRANSFER BOX, 3/4" pitch, assy.	1
1A	40054A07	/ 1990	# TRANSFER BOX, 1" pitch, assy. # <i>Interchangeable as complete units</i>	1
1	40331A01		CASE & COVER, assembly	1
3	30072A01		GASKET	1
4	10294A01		SPROCKET, 15T (1" pitch)	1
4	10294A04		SPROCKET, 20T (3/4" pitch)	1
5	20076A01		SPROCKET, 26T (1" pitch)	1
5	20076A02		SPROCKET, 35T (3/4" pitch)	1
6	80S01		CHAIN, (1" pitch)	1
6	80S04		CHAIN, (3/4" pitch)	1
7	81S01		LINK, connecting, (1" pitch)	1
7	81S02		LINK, connecting, (3/4" pitch)	1
8	88S06		BEARING	4
9	10299A01		SHAFT, input	1
10	10300A01		SHAFT, output	1
11	20078A01		FLANGE, input, c/w brake disc	1
12	10384A01		FLANGE, output	2
13	10562A01		HOUSING, oil seal	3
14	89S02		SEAL, OIL	3
15	90S02F		SCREW, cap	16
16	10293A01		GASKET	4
17	10S06		WASHER	3
18	107S07		NUT, locking	3
19	10298A01		COVER, end	1
22	10305A01		BREATHER	1
23	10301A01		PLUG, level/filler	1
24	42S05		WASHER, fibre	1
25	8S02C		BOLT	24
26	267S04		WASHER, flat	24
27	17S03		WASHER, spring	24
28	7S02		NUT	24
30	11S05D		SCREW, set	4
31	267S07		WASHER, flat	4
32	61S05		NUT, locking	4

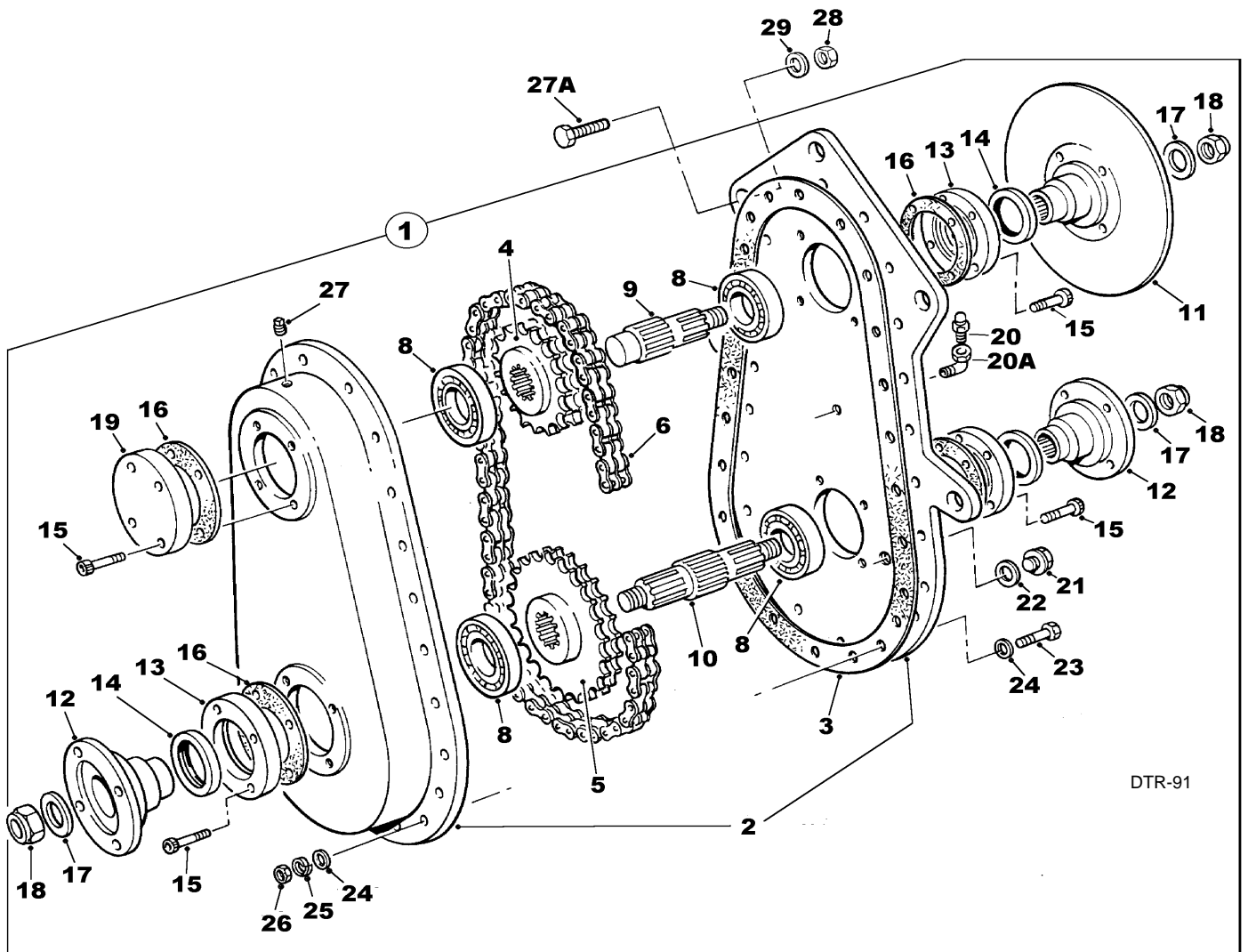

DTR-91



# TRANSFER BOX, Duplex chain

4 - F - 3

Item	Part no	Date	Description	Qty
<p><b>NOTE:</b> Before ordering parts, please ascertain whether the transfer gearbox has Simplex or Duplex chain(s). For Duplex chain see list below. For Simplex chains, see page 4-F-2.</p>				
1	40054A10	June 90 /	TRANSFER BOX, (model 543) assy.	1
2	40331A01		CASE & COVER, assembly	1
3	30072A01		GASKET	1
4	10508A01		SPROCKET, upper, 24T (5/8" pitch)	1
5	10505A01		SPROCKET, lower, 41T (5/8" pitch)	1
6	168S03		CHAIN, (5/8" pitch), duplex 'endless'	1
8	88S06		BEARING	4
9	10299A01		SHAFT, input	1
10	10300A01		SHAFT, output	1
11	20078A01		FLANGE, input, c/w brake disc	1
12	30218A0203		FLANGE, output	2
13	10562A01		HOUSING, oil seal	3
14	89S02		SEAL, OIL	3
15	90S02F		SCREW, cap	16
16	10293A01		GASKET	4
17	10S06		WASHER	3
18	107S07		NUT, locking	3
19	10298A01		COVER, end	1
20	10305A01		BREATHER	1
20A	V601446		ELBOW	1
21	10301A01		PLUG, level/filler	1
22	42S05		WASHER, fibre	1
23	8S02C		BOLT	24
24	267S04		WASHER, flat	24
25	17S03		WASHER, spring	24
26	7S02		NUT	24
27	V2003284		PLUG, blanking	1
27A	11S05D		SCREW, set	4
28	61S05		NUT, locking	4
29	267S07		WASHER, flat	4

***Section***

**5**

# ***ELECTRICS***

## **STARTING & CHARGING CIRCUITS**

---

<b>Lister ST3</b>	<b>5 - A - 1</b>
-------------------	------------------

---

<b>Petter PH2</b>	<b>5 - A - 2</b>
-------------------	------------------

---

<b>Lister TS3 &amp; TR3</b>	<b>5 - A - 3</b>
-----------------------------	------------------

---

## **BATTERY, LEADS & INSTRUMENT PANEL**

---

	<b>5 - A - 4</b>
--	------------------

---

## **ROAD LIGHTING CIRCUIT**

<b><i>4B2500 up to serial number 0796</i></b>	<b>5 - B - 1</b>
---	------------------

---

<b><i>4B3000 up to serial number 0808</i></b>	
---	--

---

<b><i>4B2500 from serial number 0797</i></b>	<b>5 - B - 2</b>
--	------------------

---

<b><i>4B3000 from serial number 0809</i></b>	
--	--

---

## **FLASHING BEACON**

---

	<b>5 - C - 1</b>
--	------------------

---

***< To begining of Parts***

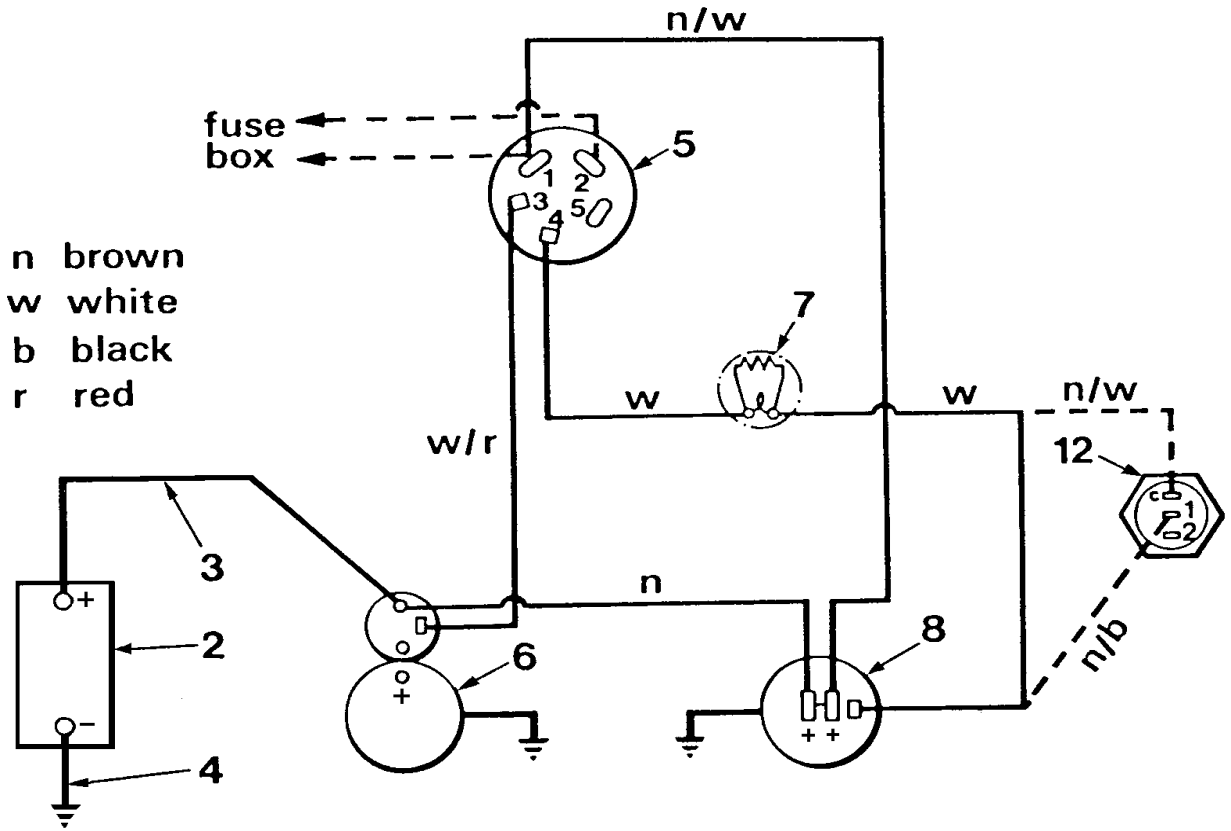

**CHARGING & STARTING CIRCUIT**  
**Lister ST3 engine**

**5 - A - 1**

<b>Item</b>	<b>Part no</b>	<b>Serial no</b>	<b>Description</b>	<b>Qty</b>
1	30231A05	/ 500099	WIRING HARNESS	1
1	30231A09	500100 /	WIRING HARNESS	1
2	109S08		BATTERY	1
3	10989A02	/ 500099	CABLE, positive	1
3	10989A01	500100 /	CABLE, positive	1
4	10990A02		CABLE, negative	1
<b>Items supplied with engine</b>				
5	-		SWITCH, start	1
6	-		STARTER, c/w solenoid	1
7	-		LIGHT, warning, c/w excitor	1
8	-		ALTERNATOR	1
12	10964A01		SWITCH, pressure ( <i>where fitted</i> )	1

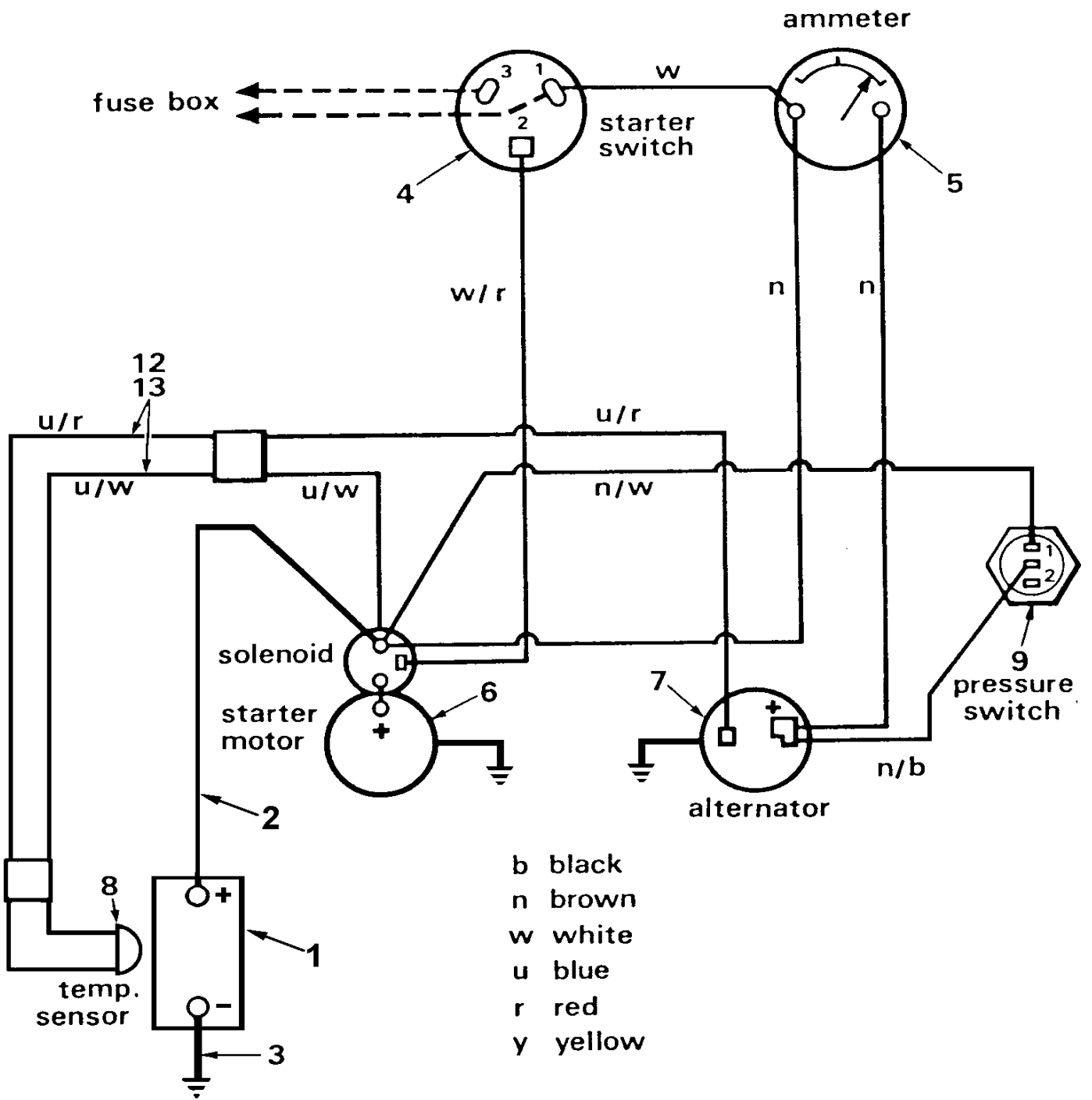

**CHARGING & STARTING CIRCUIT****5 - A - 2****Petter engine**

<b>Item</b>	<b>Part no</b>	<b>Serial no</b>	<b>Description</b>	<b>Qty</b>
1	109S08		BATTERY	1
2	10989A02	/ 500099	CABLE, positive	1
2	10989A01	500100 /	CABLE, positive	1
3	10990A02		CABLE, negative	1
<b>Items supplied with engine</b>				
4	-		SWITCH, start	1
5	-		AMMETER	1
6	-		STARTER, c/w solenoid	1
7	-		ALTERNATOR	1
8	-		SENSOR, temperature	1
9	-		SWITCH, pressure	1
12	10961A01		LEAD, extension	1
13	10961A0101		PLUG	2

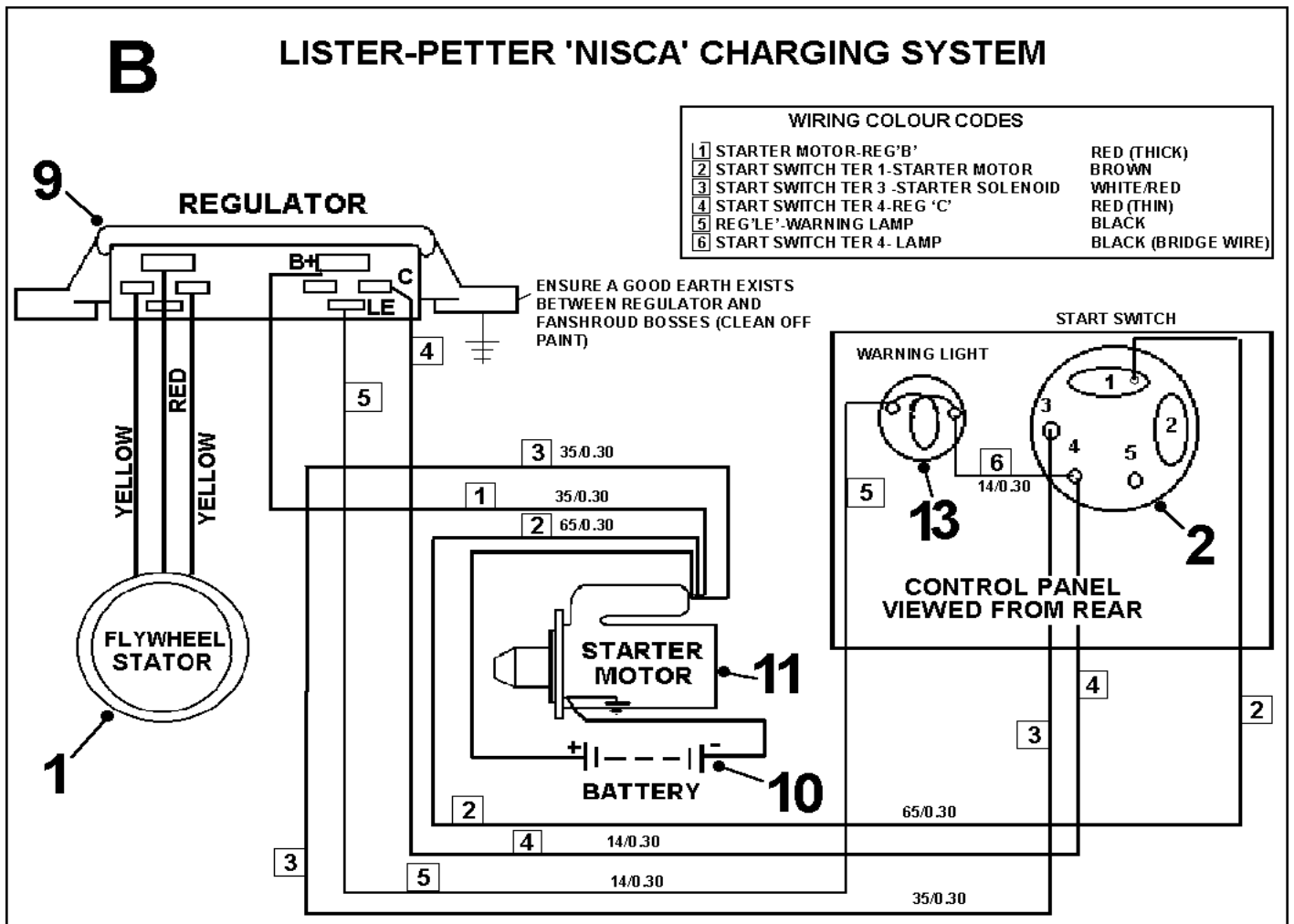
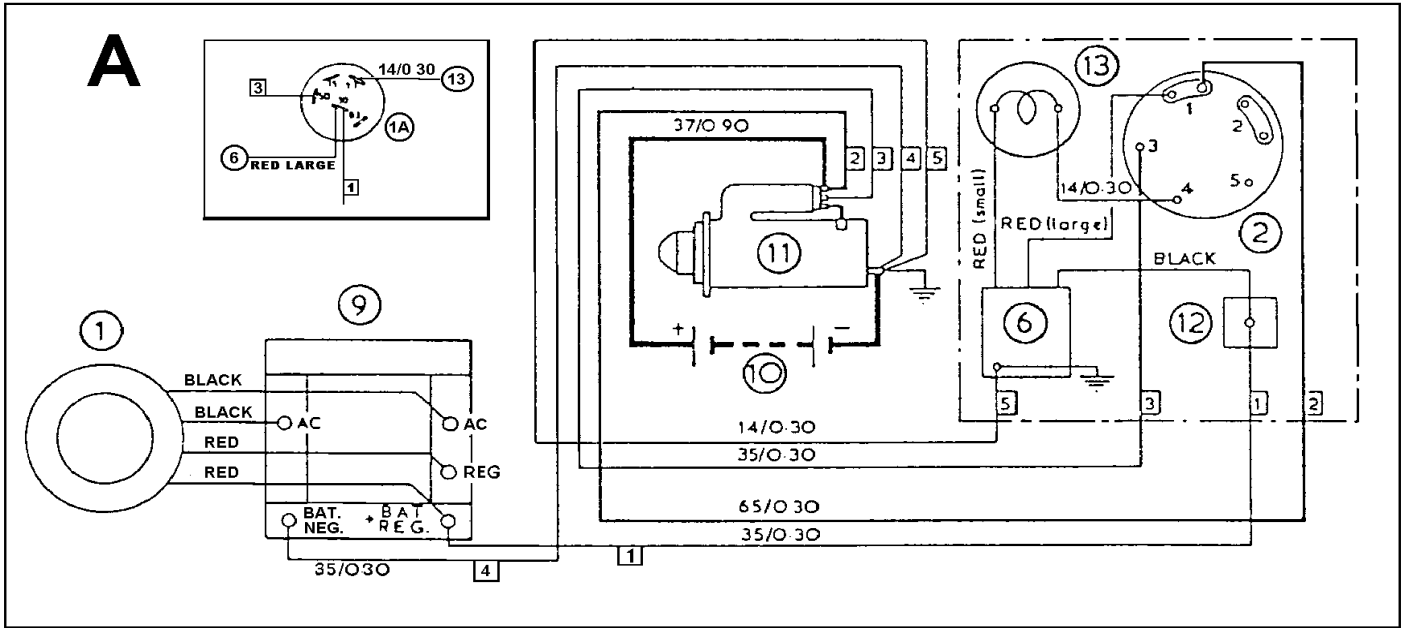



# CHARGING & STARTING CIRCUIT

## Lister TS3 & TR3 engines

5 - A - 3

Item	Part no	Serial no	Description	Qty
------	---------	-----------	-------------	-----

**NOTE:** Up to February 1991, engines were fitted with 'Syncro' charging systems (see illustration **A**).  
 From February 1991, engines were fitted with 'Nicsa' charging systems (see illustration **B**).  
 The two systems are not interchangeable.  
 Ascertain whether the engine is fitted with 'Syncro' or 'Nicsa' charging system before ordering parts.

### Engines fitted with 'Syncro' charging system (illustration A)

1	-		# STATOR, flywheel alternator	1
2	-		# SWITCH, key start	1
6	-		# INDICATOR, battery charge	1
9	-		# RECTIFIER / REGULATOR	1
10	109S08		BATTERY	1
11	-		# STARTER MOTOR	1
13	-		# LIGHT, warning	1
-	30231A09		LOOM, wiring	1

# Items supplied with engine.

For engine parts, see "Engine Parts Catalogue".

### Engines fitted with 'Nicsa' charging system (illustration B)

1	-		# STATOR, flywheel alternator	1
2	-		# SWITCH, key start	1
9	-		# REGULATOR	1
10	109S08		BATTERY	1
11	-		# STARTER MOTOR	1
13	-		# LIGHT, warning	1
-	30231A11		LOOM, wiring	1

# Items supplied with engine.

For engine parts, see "Engine Parts Catalogue".

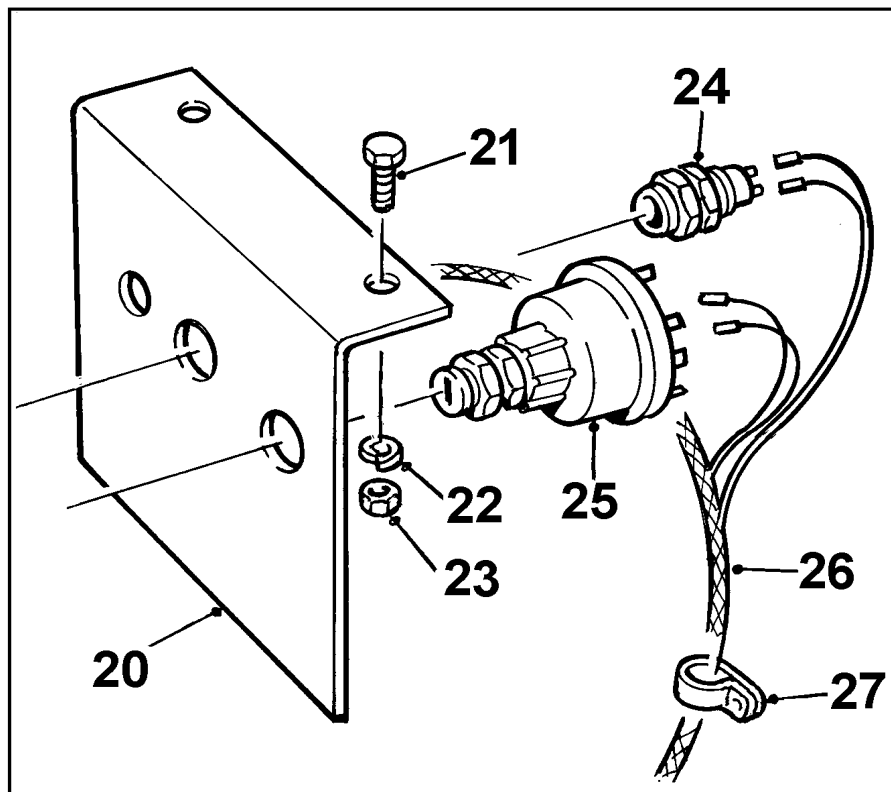
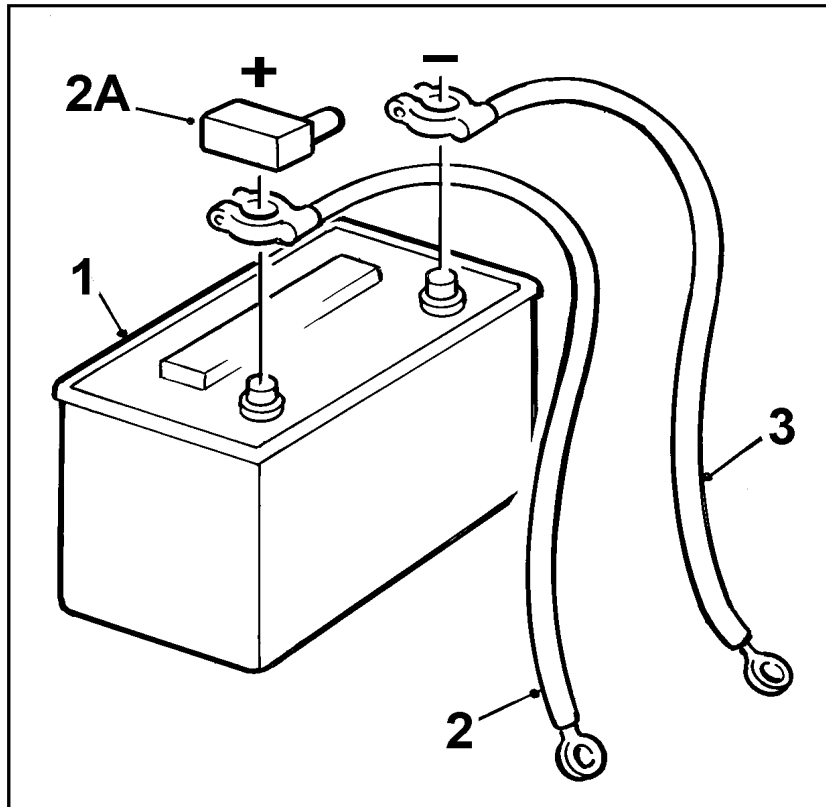

**BATTERY, LEADS & INSTRUMENT PANEL**  
**Lister TS3 & TR3 engines**

**5 - A - 4**

<b>Item</b>	<b>Part no</b>	<b>Serial no</b>	<b>Description</b>	<b>Qty</b>
1	109S08		BATTERY	1
2	10989A01		CABLE, positive	1
2A	V2004204		INSULATOR, battery positive	1
3	10990A02		CABLE, negative	1
20	20313A05		PANEL, instrument	1
21	11S04B		SCREW, set	2
22	17S05		WASHER, spring	2
23	7S04		NUT	2
24	V602634		LIGHT, light warning	1
25	V2004189		SWITCH, engine start	1
.....	V601179		KEY, engine start	
.....	V2003540		RING, key	
26	30231A11		LOOM, wiring	1
27	V2003377		CLIP, loom	1



# ROAD LIGHTING CIRCUIT

5 - B - 1

Item	Part no	Serial no	Description	Qty
		/ 0796	<b>4B2500</b>	
		/ 0808	<b>4B3000</b>	
-	20105A12		WIRING LOOM	1
2	20013A0112		HEADLAMP	2
3	10216A01		GUARD, stone	2
4	V2003147		LIGHT, rear, L.H.	1
4	V2003148		LIGHT, rear, R.H.	1
5	V2003146		LIGHT, side/indicator	2
-	11S01AA		SCREW	16
-	7S01		NUT	16
-	267S03		WASHER, flat	16
6	V2003167		LIGHT, number plate	1
7	10617A01		SWITCH, indicator	1
-	82S07C		SCREW	2
-	85S03		NUT	2
8	10616A01		FLASHER UNIT	1
-	82S03C		SCREW	1
-	12S01		WASHER, flat	1
-	85S01		NUT	1
9	10619A01		BUTTON, horn	1
10	V2003150		HORN	1
-	82S07E		SCREW	2
-	85S03		NUT	2
11	V2003278		SWITCH, light	1
12	10644A01		FUSE BOX	1
-	82S03E		SCREW	1
-	85S01		NUT	1
14	V2003168		SWITCH, brake	1
-	116S02		WASHER	1
-	8S02A		BOLT	2
-	7S02		NUT	2
-	267S16		WASHER, flat	2
-	V2003111		TIE, cable, small	AR
-	V2003166		TIE, cable, large	AR



## ROAD LIGHTING CIRCUIT

5 - B - 2

Item	Part no	Serial no	Description	Qty
		0797 /	<b>4B2500</b>	
		0809 /	<b>4B3000</b>	
1	20105A16		LOOM, wiring	1
2	143200900		CLIP, 'P', nylon	10
3	16S05B		SCREW, set	10
4	267S02		WASHER, flat	10
5	17S10		WASHER, spring	10
6	7S09		NUT	10
7	V2003111		TIE, cable (200mm long)	35
7	V2003253		TIE, cable (400mm long)	6
10	V2003638		LIGHT, head	2
12	11038A01		BRACKET, head light	2
13	11S05H		SCREW, set	4
14	267S07		WASHER, flat	4
15	17S06		WASHER, spring	4
16	7S06		NUT	
20	.....		BRACKET, <i>(make from bracket 11038A01 for dumpers with high discharge or rotating skips)</i>	
21	11S03E		SCREW, set	4
22	267S05		WASHER, flat	4
23	17S04		WASHER, spring	4
24	7S03		NUT	4
25	V2003637		LIGHT, front L/H. assembly	1
26	V2003652		LIGHT, front R/H. assembly	1
27	.....		BULB, indicator, 12V 21W	1
28	.....		BULB, sidelight, 12V 5W	1
29	11S01C		SCREW, set	2
30	17S02		WASHER, spring	2
31	7S01		NUT	2
34	V2003636		LIGHT, rear L/H. assembly	1
35	V2003651		LIGHT, rear R/H. assembly	1
36	.....		BULB, indicator, 12V 21W	1
37	.....		BULB, brake/rear side, 12V 21/5W	1
40	V2003639		LIGHT, number plate	1
41	191906000		CONNECTOR, Lucar 1/4" female	2
45	V2003168		SWITCH, brake light	1
46	10S04		WASHER, flat	2
47	95S05		NUT, brake light switch	1

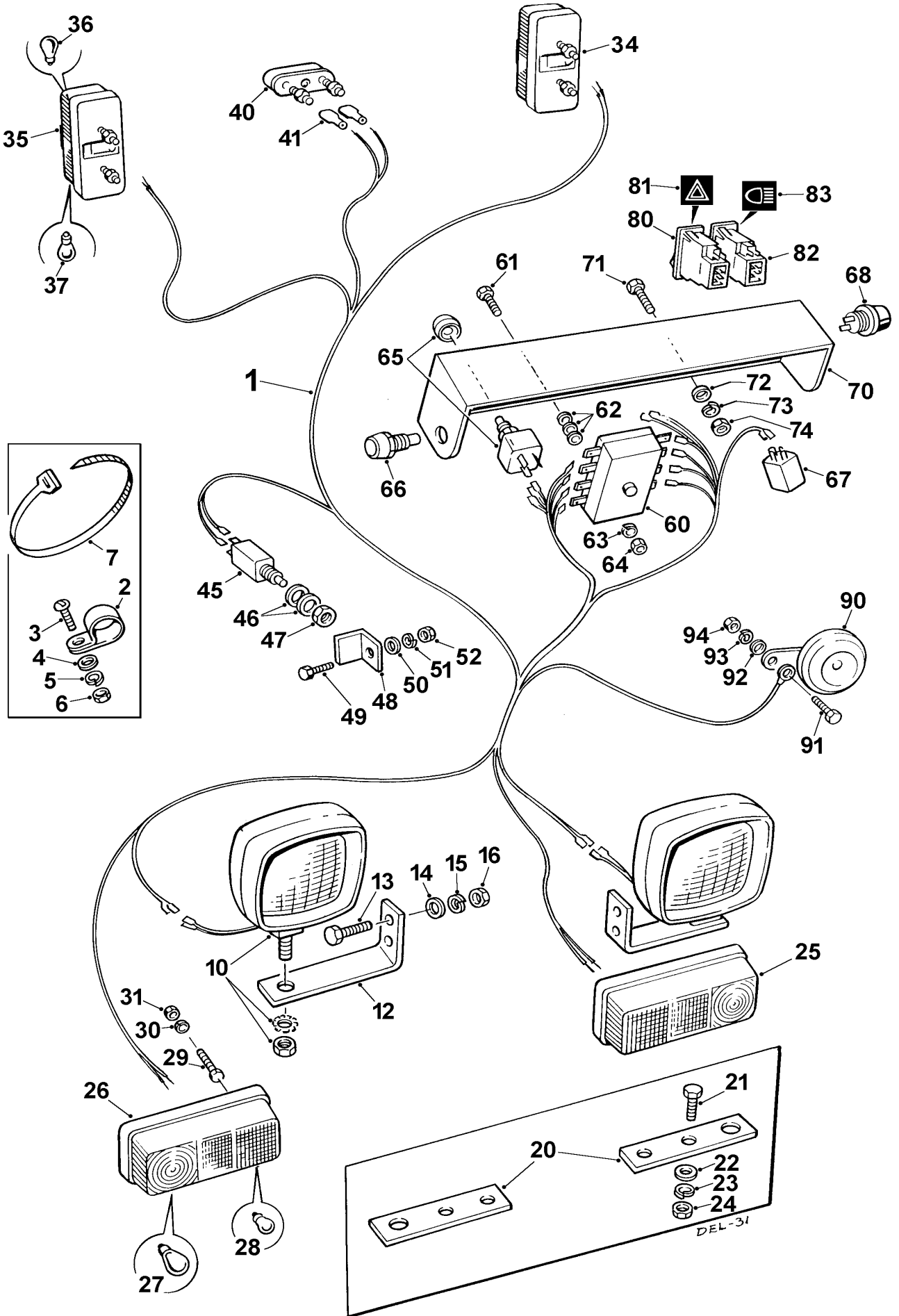



## ROAD LIGHTING CIRCUIT

5 - B - 2

Item	Part no	Serial no	Description	Qty
48	V2004768		BRACKET, brake light switch.	1
49	11S03C		SCREW, set	1
50	267S05		WASHER, flat	1
51	17S04		WASHER, spring	1
52	7S03		NUT	1
60	V2003176		FUSE BOX, obsolete use item 60A	1
60A	V601177		FUSE BOX	1
60B	V2003177		FUSE, bullet, use with item 60	AR
60C	V601173		FUSE, blade, use with item 60A	AR
61	11S01A		SCREW, set	2
62	267S03		WASHER, flat	6
63	17S02		WASHER, spring	2
64	7S01		NUT	2
65	V2003642		SWITCH, direction indicators	1
66	V2000326		LIGHT, warning Indicator	1
67	V2003640		UNIT, flasher	1
68	V2003570		BUTTON, horn	1
70	20313A11		PANEL, instruments	1
71	11S02B		SCREW, set	2
72	267S04		WASHER, flat	2
73	17S03		WASHER, spring	2
74	7S02		NUT	2
80	V2003641		SWITCH, hazard lights	1
81	V2006347		INSERT, hazard lights	1
82	V2003644		SWITCH, lights	1
83	V2003646		INSERT, mainbeam	1
90	V2003144		HORN	1
91	11S03B		SCREW, set	1
92	267S05		WASHER, flat	1
93	17S04		WASHER, spring	1
94	7S03		NUT	1

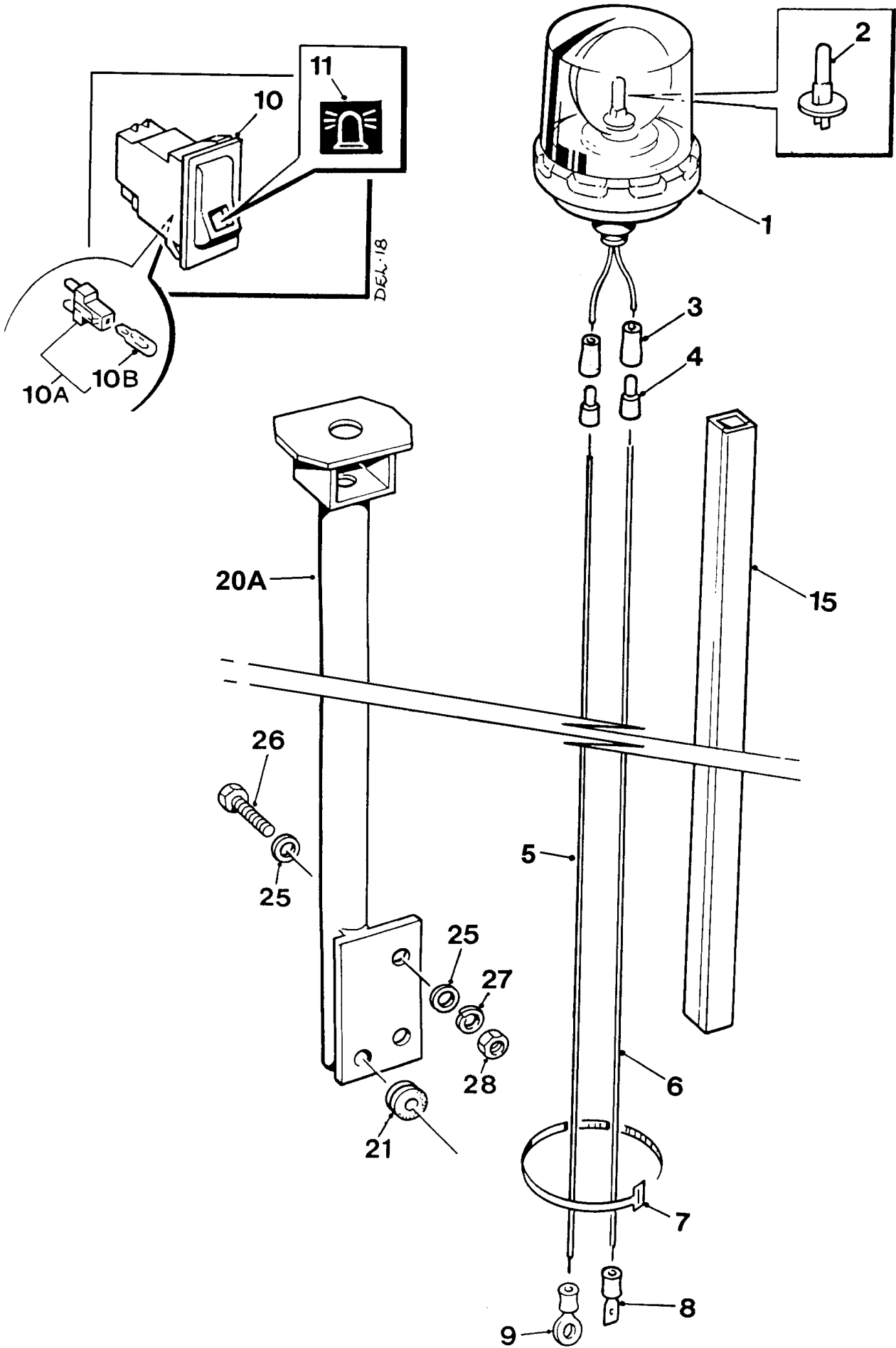

Item	Part no	Serial no	Description	Qty
1	V2003576		BEACON, assembly	1
2	V600430		BULB, beacon	1
3	191901100		CONNECTOR, 'Bullet' female	2
4	191901800		CONNECTOR, 'Bullet' male	2
5	144779002		WIRE, black, 'earth'	3 metres
6	144776002		WIRE, orange, 'positive'	3 metres
.....	208143001		SLEEVE, black ( <i>not illustrated</i> )	2
7	V2003111		TIE, nylon	2
8	V2003583		CONNECTOR, Lucar, male, 'positive'	1
9	191901700		CONNECTOR, ring 8mm, 'earth'	1
10	V2003577		SWITCH, off/on, assembly	1
10A	V601800		RETAINER & BULB, assembly	1
10B	V602399		BULB	
11	V2003578		INSERT, beacon switch	1

**Beacon with ROPS**

15	V2004043		CONDUIT	( <i>order by meter</i> )	AR
21	V2003252		GROMMET, open		1

**Beacon without ROPS**

20A	V2004999		SUPPORT, beacon		1
21	V2003252		GROMMET, open		1
25	267S06		WASHER, flat		4
26	11S04D		SCREW, set		2
27	17S05		WASHER, spring		2
28	7S04		NUT		2

***Section***

**6**

# ***SKIPS***

## **SKIP, forward tipping**

**1.13m<sup>3</sup>**

---

**6 - A - 1**

**1.1m<sup>3</sup> & 1.3m<sup>3</sup>**

---

**6 - A - 2**

## **SKIP, rotating**

---

**6 - A - 3**

## **SKIP, high discharge**

---

**6 - A - 4**

***< To begining of Parts***

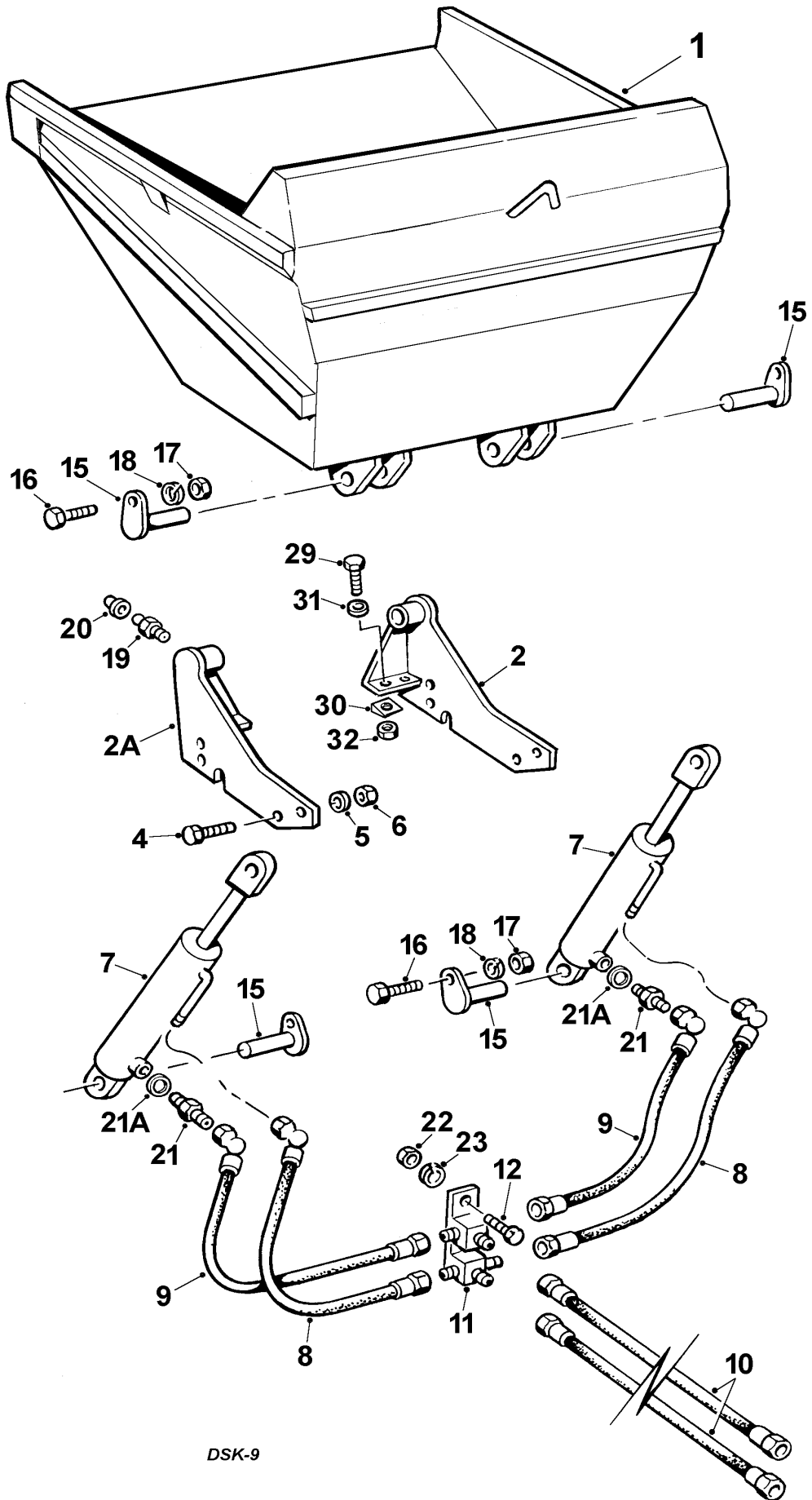

DSK-9

Item	Part no	Serial no	Description	Qty
1	40088A04		SKIP, <b>4B2500</b>	1
1	40107A04		SKIP, <b>4B3000</b>	1
2	30126A12	/ 0174	BRACKET, skip pivot, R.H., <b>4B2500</b>	1
2	30126A18	0175 /	BRACKET, skip pivot, R.H., <b>4B2500</b>	1
2	30126A12	/ 0155	BRACKET, skip pivot, R.H., <b>4B3000</b>	1
2	30126A18	0156 /	BRACKET, skip pivot, R.H., <b>4B3000</b>	1
2A	30126A13	/ 0174	BRACKET, skip pivot, L.H., <b>4B2500</b>	1
2A	30126A19	0175 /	BRACKET, skip pivot, L.H., <b>4B2500</b>	1
2A	30126A13	/ 0155	BRACKET, skip pivot, L.H., <b>4B3000</b>	1
2A	30126A19	0156 /	BRACKET, skip pivot, L.H., <b>4B3000</b>	1
4	8S06J		BOLT	8
5	267S09		WASHER, flat	8
6	59S11		NUT, nylon insert	8
7	.....		RAM, hyd ( <i>see Hydraulics Section</i> )	2
8	33S02H	/ 0141	HOSE, 470mm long, <b>4B2500</b>	2
8	33S02J	0142 /	HOSE, 570mm long, <b>4B2500</b>	2
8	33S02H	/ 0110	HOSE, 470mm long, <b>4B3000</b>	2
8	33S02J	0111 /	HOSE, 570mm long, <b>4B3000</b>	2
9	31S02GG		HOSE, bracket to ram	2
10	35S02AF		HOSE, bulkhead to bracket	2
11	435388		BRACKET, tee	1
12	11S02C		SCREW, set	1
15	10470A02		PIN, ram pivot	4
16	11S04E		SCREW, set	4
17	7S04		NUT	4
18	17S05		WASHER, spring	4
19	131S03	/ 0783	NIPPLE, grease, <i>push-in</i> , <b>4B2500</b>	2
19	131S03	/ 0788	NIPPLE, grease, <i>push-in</i> , <b>4B3000</b>	2
19	131S01	0784 /	NIPPLE, grease, <i>threaded</i> , <b>4B2500</b>	2
19	131S01	0789 /	NIPPLE, grease, <i>threaded</i> , <b>4B3000</b>	2
20	176S01		CAP, grease nipple	2
21	122S03		ADAPTOR	2
21A	100S03		SEAL, bonded	2
22	7S02		NUT	2
23	17S03		WASHER, spring	2
29	11S06G		SCREW, set	4
30	105S07		WASHER, taper	4
31	267S09		WASHER, flat	4
32	59S11		NUT, 'Nylloc' nylon insert	4

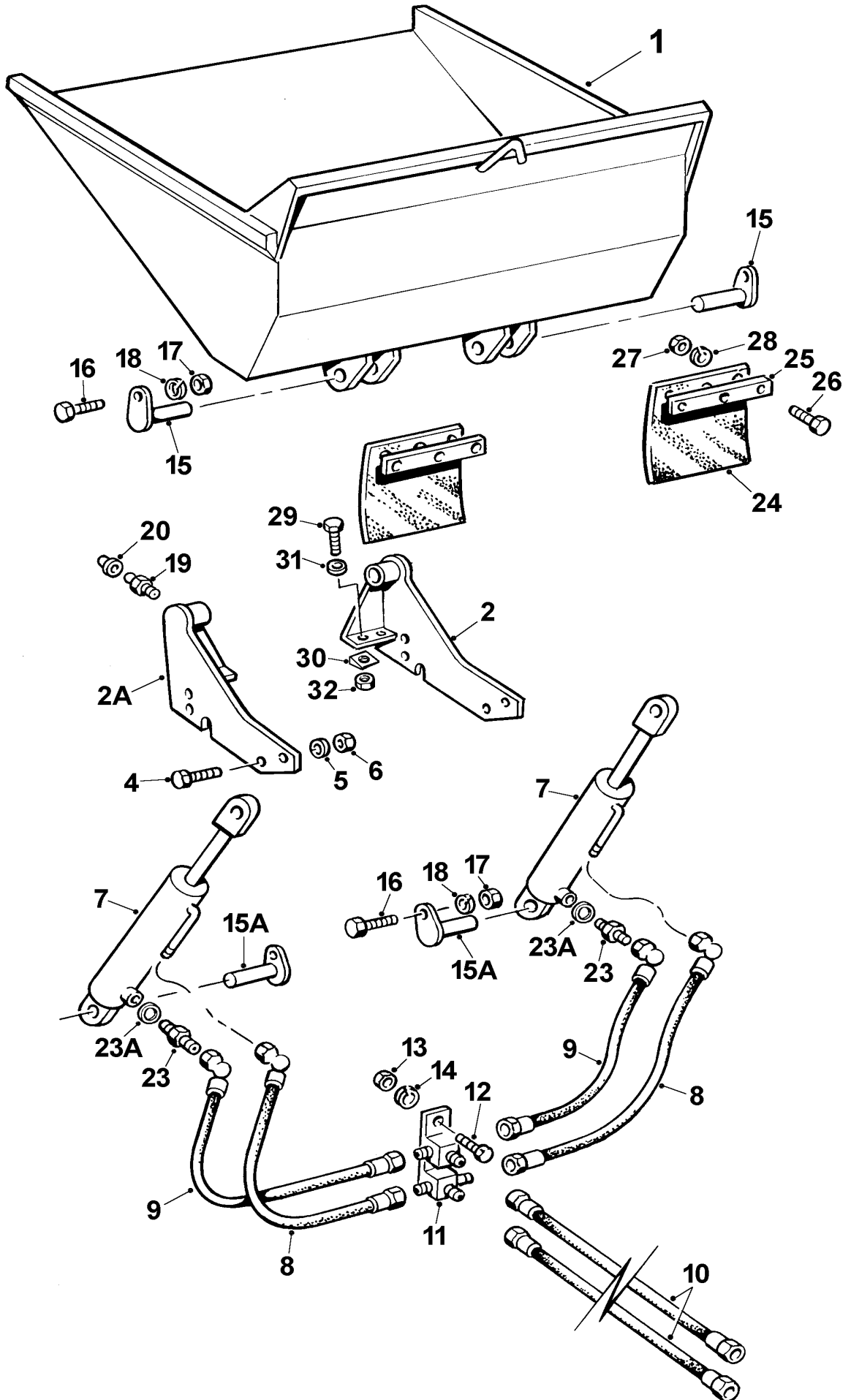



**SKIP, forward tipping, 1.1m<sup>3</sup>(35ft<sup>3</sup>) and 1.3m<sup>3</sup>(45ft<sup>3</sup>)**

**6 - A - 2**

<b>Item</b>	<b>Part no</b>	<b>Serial no</b>	<b>Description</b>	<b>Qty</b>
1	40276A03		SKIP, <b>4B2500</b>	1
1	40277A03		SKIP, <b>4B3000</b>	1
2	30126A12	/ 0174	BRACKET, skip pivot, R.H., <b>4B2500</b>	1
2	30126A18	0175 /	BRACKET, skip pivot, R.H., <b>4B2500</b>	1
2	30126A12	/ 0155	BRACKET, skip pivot, R.H., <b>4B3000</b>	1
2	30126A18	0156 /	BRACKET, skip pivot, R.H., <b>4B3000</b>	1
2A	30126A13	/ 0174	BRACKET, skip pivot, L.H., <b>4B2500</b>	1
2A	30126A19	0175 /	BRACKET, skip pivot, L.H., <b>4B2500</b>	1
2A	30126A13	/ 0155	BRACKET, skip pivot, L.H., <b>4B3000</b>	1
2A	30126A19	0156 /	BRACKET, skip pivot, L.H., <b>4B3000</b>	1
4	8S06J		BOLT	8
5	267S09		WASHER, flat	8
6	59S11		NUT, nylon insert	8
7	.....		RAM, hyd ( <i>see Hydraulics Section</i> )	2
8	33S02H	/ 0141	HOSE, 470mm long, <b>4B2500</b>	2
8	33S02J	0142 /	HOSE, 570mm long, <b>4B2500</b>	2
8	33S02H	/ 0110	HOSE, 470mm long, <b>4B3000</b>	2
8	33S02J	0111 /	HOSE, 570mm long, <b>4B3000</b>	2
9	31S02GG		HOSE, bracket to ram	2
10	35S02AG		HOSE, bulkhead to bracket	2
11	435388		BRACKET, tee	1
12	11S02C		SCREW, set	1
13	7S02		NUT	2
14	17S03		WASHER, spring	2
15	10470A03		PIN, ram upper pivot	2
15A	10470A02		PIN, ram lower pivot	2
16	11S04E		SCREW, set	4
17	7S04		NUT	4
18	17S05		WASHER, spring	4
19	131S03	/ 0783	NIPPLE, grease, <i>push-in</i> , <b>4B2500</b>	2
19	131S03	/ 0788	NIPPLE, grease, <i>push-in</i> , <b>4B3000</b>	2
19	131S01	0784 /	NIPPLE, grease, <i>threaded</i> , <b>4B2500</b>	2
19	131S01	0789 /	NIPPLE, grease, <i>threaded</i> , <b>4B3000</b>	2
20	176S01		CAP, grease nipple	2



**SKIP, forward tipping, 1.1m<sup>3</sup>(35ft<sup>3</sup>) and 1.3m<sup>3</sup>(45ft<sup>3</sup>)****6 - A - 2**

<b>Item</b>	<b>Part no</b>	<b>Serial no</b>	<b>Description</b>	<b>Qty</b>
23	122S03		ADAPTOR	2
23A	100S03		SEAL, bonded	2
24	10483A01		FLAP, rubber	2
25	10484A01		PLATE, clamp	2
26	11S04E		SCREW, set	6
27	7S04		NUT	6
28	17S05		WASHER, spring	6
29	11S06G		SCREW, set	4
30	105S07		WASHER, taper	4
31	267S09		WASHER, flat	4
32	59S11		NUT, 'Nyloc' nylon insert	4

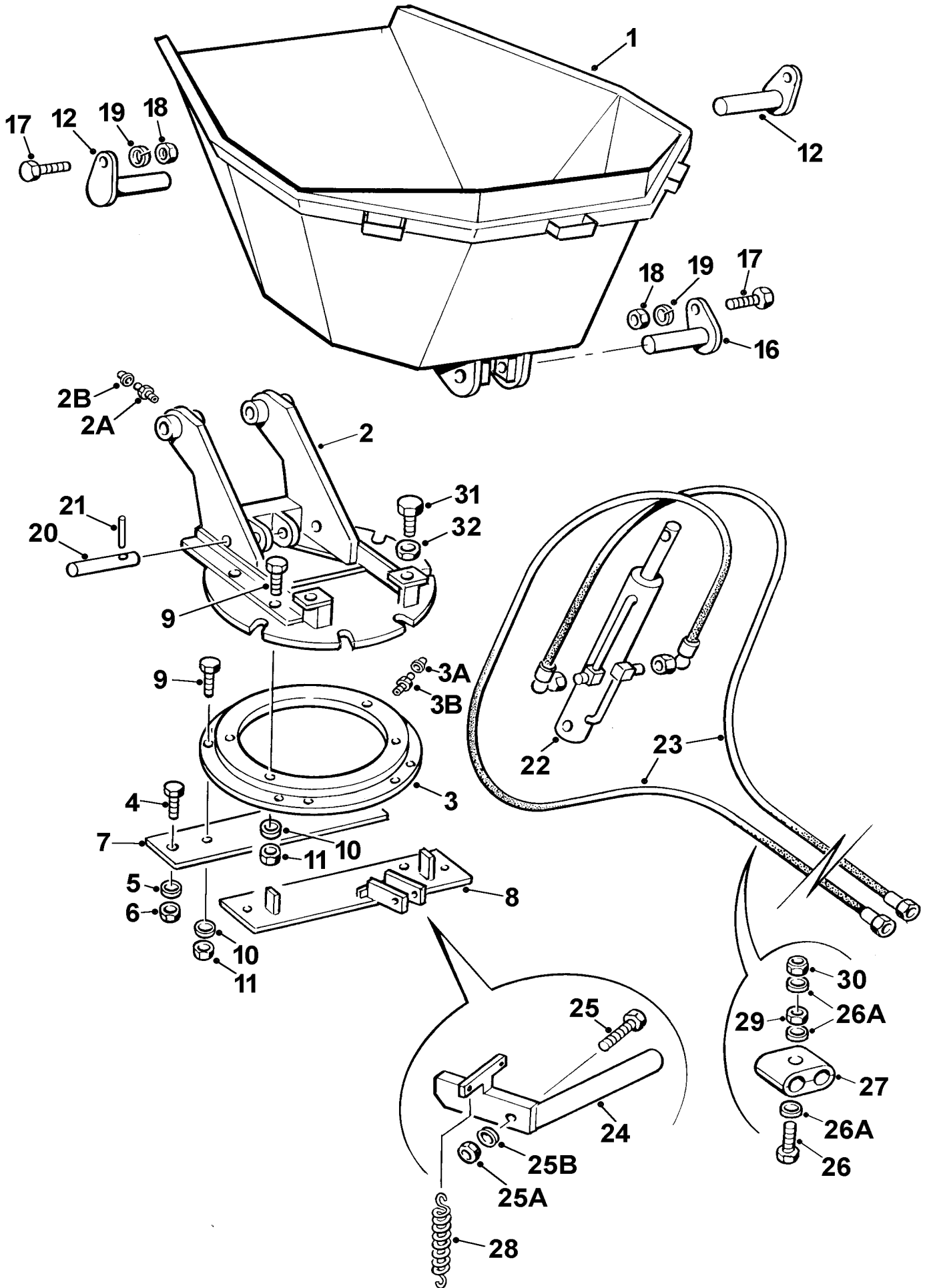

Item	Part no	Serial no	Description	Qty
1	40217A01		SKIP, narrow mouth	1
1	40217A02		SKIP, wide mouth	1
2	40116A03		FRAME, skip	1
2A	131S01		NIPPLE, grease	2
2B	176S01		CAP, grease nipple	2
3	10640A02		RING, slewing turntable	1
3A	176S01		CAP, grease nipple	4
3B	.....		NIPPLE, grease	4
4	8S05D		BOLT	4
5	267S07		WASHER, flat	8
6	59S04		NUT, nylon insert	4
7	10833A04		PLATE, front mount	1
8	30306A01		PLATE, rear mount	1
9	8S05E		BOLT	4
10	267S07		WASHER, flat	8
11	59S04		NUT, nylon insert	4
12	10522A04		PIN, skip pivot	2
16	10919A01		PIN, ram upper pivot	1
17	11S04C		SCREW, set	3
18	7S04		NUT	3
19	17S05		WASHER, spring	3
20	10720A02		PIN, ram lower pivot	1
21	55S07Q		PIN, tension	1
22	.....		RAM, hyd (see Hydraulics Section)	1
23	31S02K		HOSE, ram to bulkhead	2
24	40296A03		CATCH, skip locking	1
25	8S05H		BOLT	1
25A	59S04		NUT, 'Nyloc' self-locking	1
25B	267S07		WASHER, flat	1
26	11S02H		SCREW, set	1
26A	267S04		WASHER, flat	3
27	187S08JJ		CLAMP, hose	1 pair
28	C173D		SPRING, skip catch	2
29	7S02		NUT	1
30	61S02		NUT, 'Binx' self locking	1
31	11S07P		SCREW, set	2
32	7S07		NUT	2
.....	V2003111		TIE, nylon ( <i>not illustrated</i> )	2
.....	V2003253		TIE, nylon ( <i>not illustrated</i> )	1

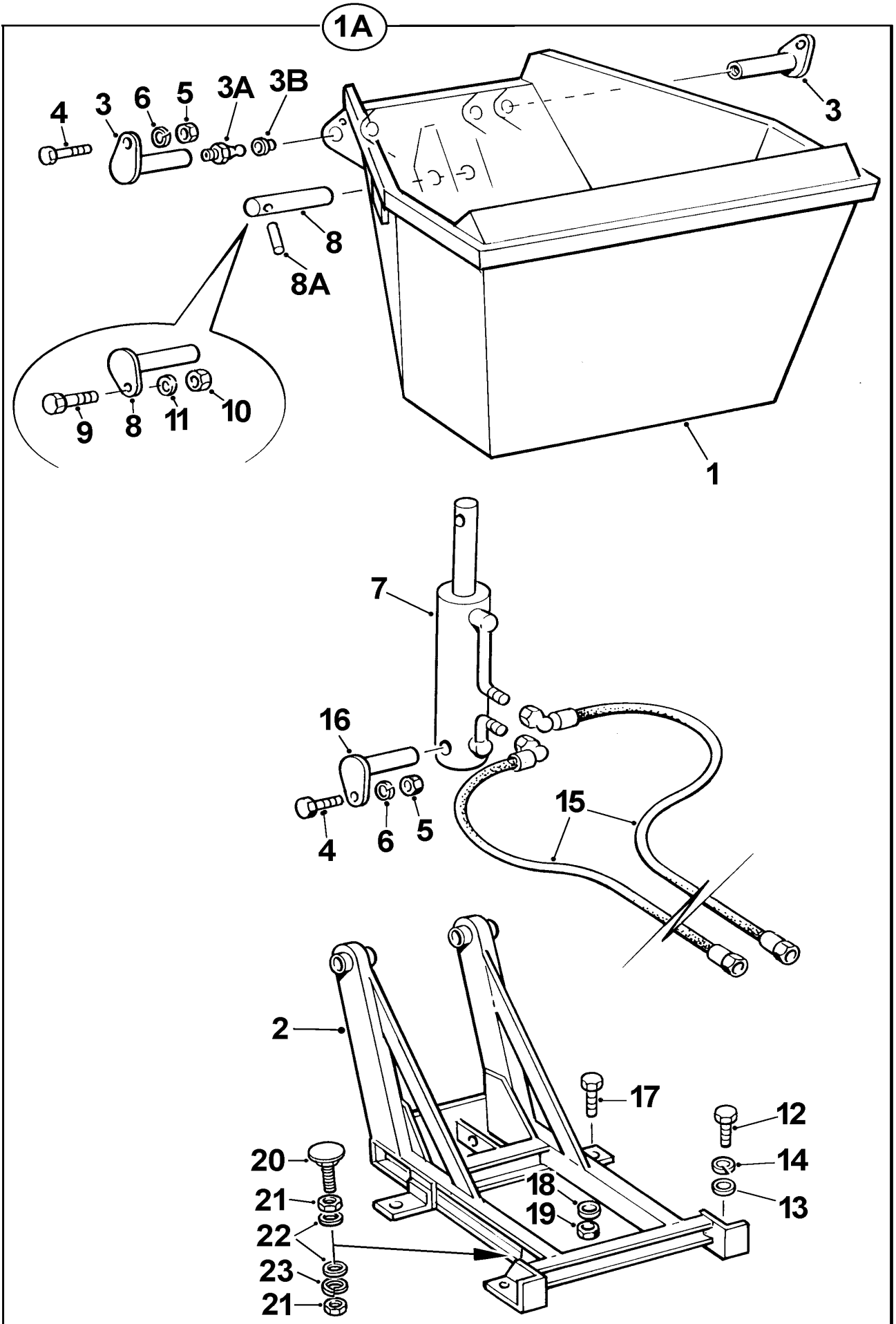

**SKIP, high discharge**

**6 - A - 4**

Item	Part no	Serial no	Description	Qty
1A	40313A01		SKIP, high discharge, assembly	1
1	40299A01		SKIP, high discharge	1
2	40252A02		FRAME	1
3	10932A01		PIN, skip pivot	2
3A	131S01		NIPPLE, grease	2
3B	176S01		CAP, grease nipple	2
4	11S04C		SCREW, set	3
5	7S04		NUT	3
6	17S05		WASHER, spring	3
7	.....		RAM, hyd ( <i>see Hydraulics Section</i> )	1
8	10919A02	/ April 90	PIN, ram upper pivot	1
8	10919A04	April 90 /	PIN, ram upper pivot	1
8A	55S07T	April 90 /	PIN, spirol	1
9	11S03C	/ April 90	SCREW, set	2
10	7S03	/ April 90	NUT	2
11	17S04	/ April 90	WASHER, spring	2
12	11S07K		SCREW, set	4
13	267S10		WASHER, flat	4
14	17S09		WASHER, spring	4
15	31S02P		HOSE, bulkhead to ram	2
16	10919A03		PIN, ram lower pivot	1
17	11S05F		SCREW, set	2
18	267S07		WASHER, flat	2
19	59S04		NUT, 'Nyloc' self-locking	2
20	V2004234		SKIP STOP	2
21	7S08		NUT	4
22	267S12		WASHER, flat	4
23	17S11		WASHER, spring	2

***Section***

**7**



# HYDRAULICS

---

<b>MAIN HYDRAULIC CIRCUIT</b>	<b>7 - A - 1</b>
<hr/>	
<b>PUMPS complete with adaptors</b>	<b>7 - A - 1A</b>
<hr/>	
<b>CONTROL VALVE, monobloc</b> <i>to serial no. 0329 for 4B2500</i> <i>to serial no. 0304 for 4B3000</i>	<b>7 - B - 1</b>
<hr/>	
<b>CONTROL VALVE, sectional</b> <i>serial no. from 0330 to 0797 for 4B2500</i> <i>serial no. from 0305 to 0808 for 4B3000</i>	<b>7 - C - 1</b>
<hr/>	
<b>SECTION of control valve</b> <i>serial no. from 0330 to 0797 for 4B2500</i> <i>serial no. from 0305 to 0808 for 4B3000</i>	<b>7 - C - 2</b>
<hr/>	
<b>CONTROL VALVE, monobloc</b> <i>from serial no. 0798 for 4B2500</i> <i>from serial no. 0809 for 4B3000</i>	<b>7 - C - 3</b>
<hr/>	
<b>RAMS, tipping: Earth skip</b>	<b>7 - R - 1</b> <b>7 - R - 1A</b>
<hr/>	
<b>RAM, tipping: High discharge skip</b>	<b>7 - R - 2</b>
<hr/>	
<b>RAM, tipping: Rotating skip</b>	<b>7 - R - 3</b>
<hr/>	
<b>RAMS, steering</b>	<b>7 - R - 4</b> <b>7 - R - 5</b>

---

**< [To begining of Parts](#)**

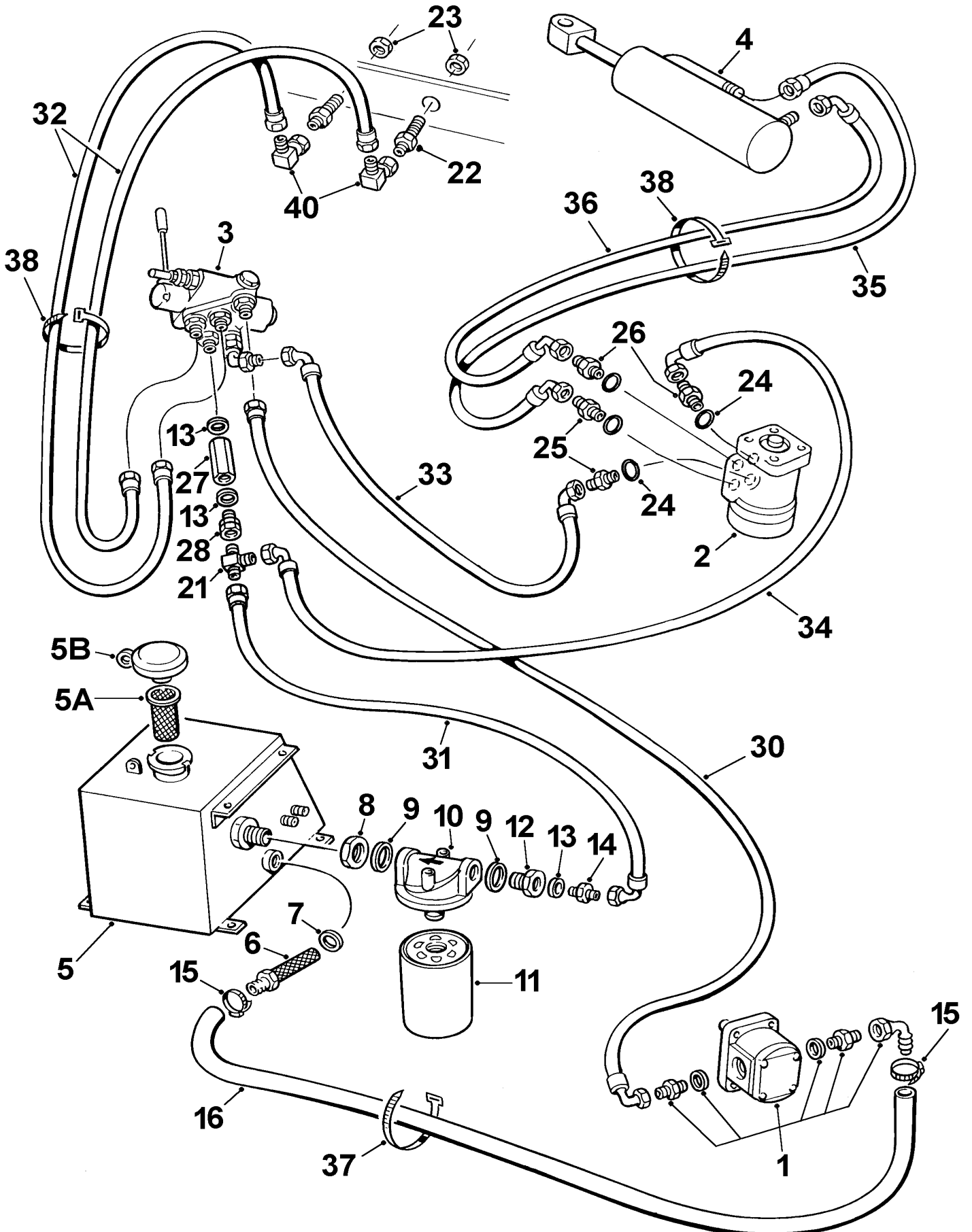

# MAIN HYDRAULIC CIRCUIT

7 - A - 1

Item	Part no	Serial no	Description	Qty
1	.....		PUMP & FITTINGS (see page 7-A-1A)	1
2	.....		VALVE, steer (see page 2-S-1)	1
3	.....		VALVE, control (see Section Index)	1
4	.....		RAM, steering (see Section Index)	1
5	40282A05		TANK, hydraulic oil <b>4B2500</b>	1
5	40282A06		TANK, hydraulic oil <b>4B3000</b>	1
5A	10379A03		FILTER/STRAINER	1
5B	10378A03		CAP, tank	1
6	901S01		FILTER/STRAINER	1
7	186S14		SEAL, nylon <b>Obsolete: use 100S08</b>	1
7	100S08		SEAL, bonded	1
8	72S07		NUT, locking	1
9	100S09		SEAL, bonded	2
10	10363A03		HEAD, filter	1
11	10363A02		ELEMENT, filter	1
12	111S01		FITTING, reducing	1
13	100S04		SEAL, bonded	3
14	122S04		FITTING, adaptor	1
15	V2003232		CLIP, hose	2
16	37S03BG		HOSE, suction (610mm), <i>Petter PH3</i>	1
16	37S03BC		HOSE, suction (1397mm), <i>Lister ST3</i>	1
16	37S03BH		HOSE, suction (1850mm), <i>Lister TS3</i>	1
21	113S01		FITTING, tee	1
22	93S01		ADAPTOR, bulkhead, c/w nut	2
23	72S01		NUT, locking	2
24	49S02		SEAL, 'O' ring	4
25	126S04		ADAPTOR, male/male	2
26	460115		FITTING, extended	2
27	10979A02		VALVE, check	1
28	112S01		ADAPTOR, male/female	1

continued >

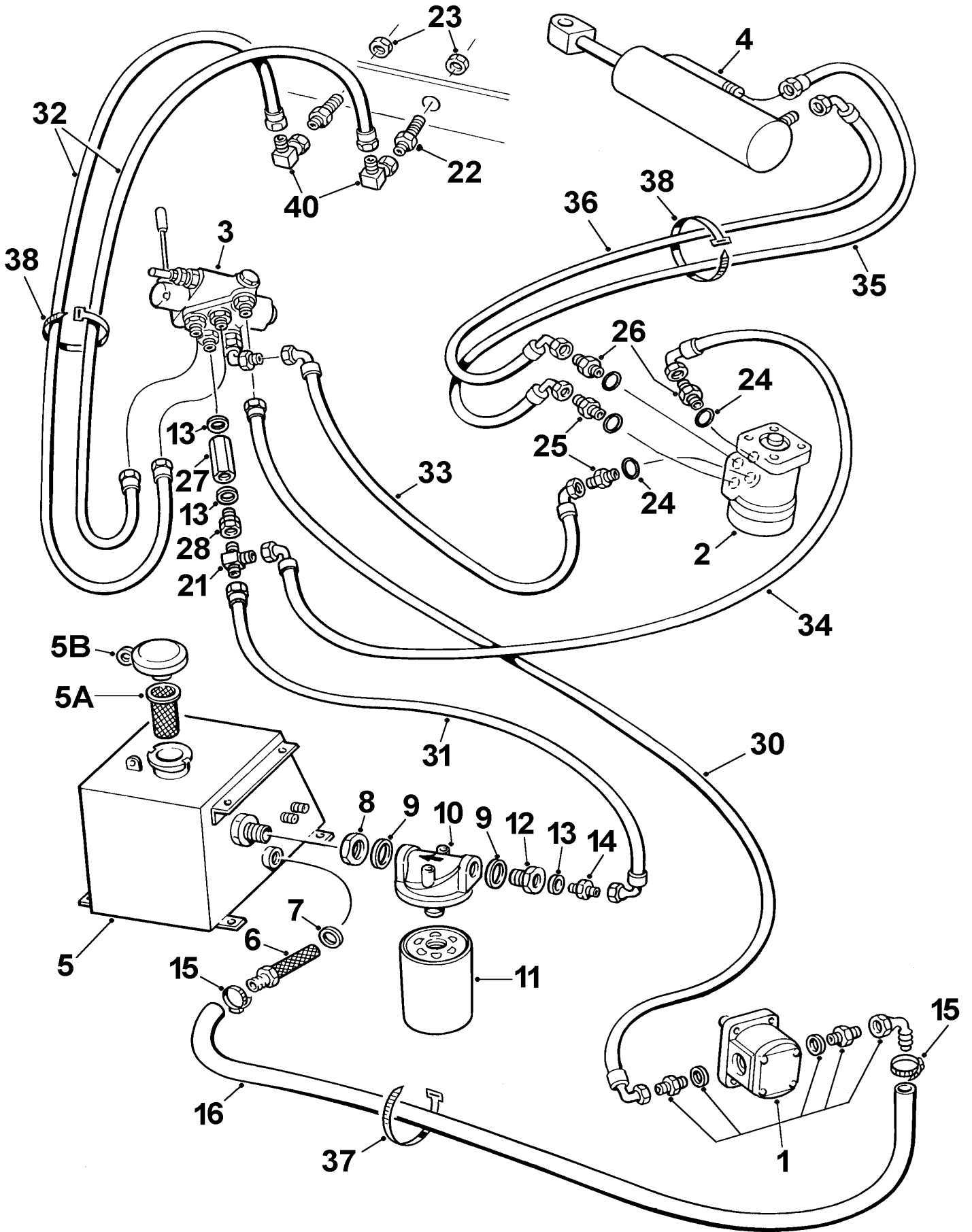

# MAIN HYDRAULIC CIRCUIT

7 - A - 1

Item	Part no	Serial no	Description	Qty
<b>Petter PH3</b>				
30	31S02Q		HOSE, (34.5"), pump to control v. inlet	1
<b>4B2500 with Lister engine</b>				
30	31S02G	/ 0784	HOSE, (77"), pump to control v. inlet	1
30	31S03I	0785 /	HOSE, (73"), pump to control v. inlet	1
<b>4B3000 with Lister engine</b>				
30	31S02G	/ 0304	HOSE, (77"), pump to control v. inlet	1
30	31S03I	0305 /	HOSE, (73"), pump to control v. inlet	1
31	36S03SS		HOSE, tee to filter	1
32	35S02AE		HOSE, control v. to bulkhead fittings	2
33	36S02B		HOSE, control v. to steer v.	1
34	36S02HH		HOSE, steer v. to return tee	1
35	31S02G		HOSE, steer v. to steer ram RETRACT	1
36	36S02HH		HOSE, steer v. to steer ram EXTEND	1
37	V2003253		TIE, cable, nylon	3
38	V2003111		TIE, cable, nylon	3
40	96S09		FITTING, elbow, compact	2

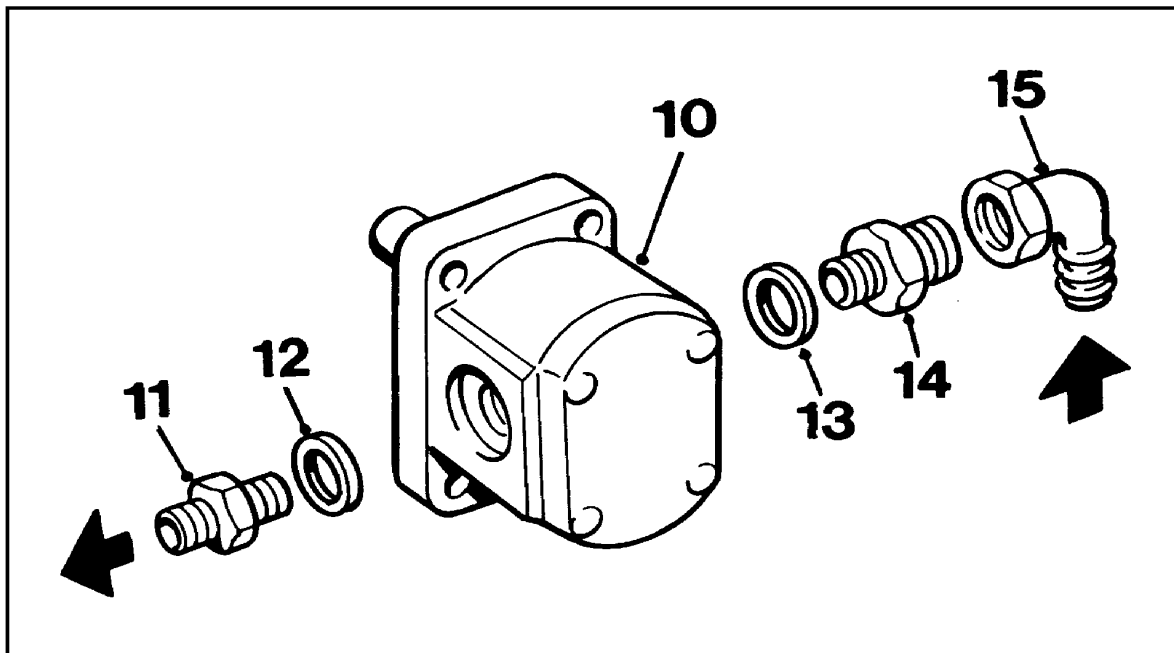
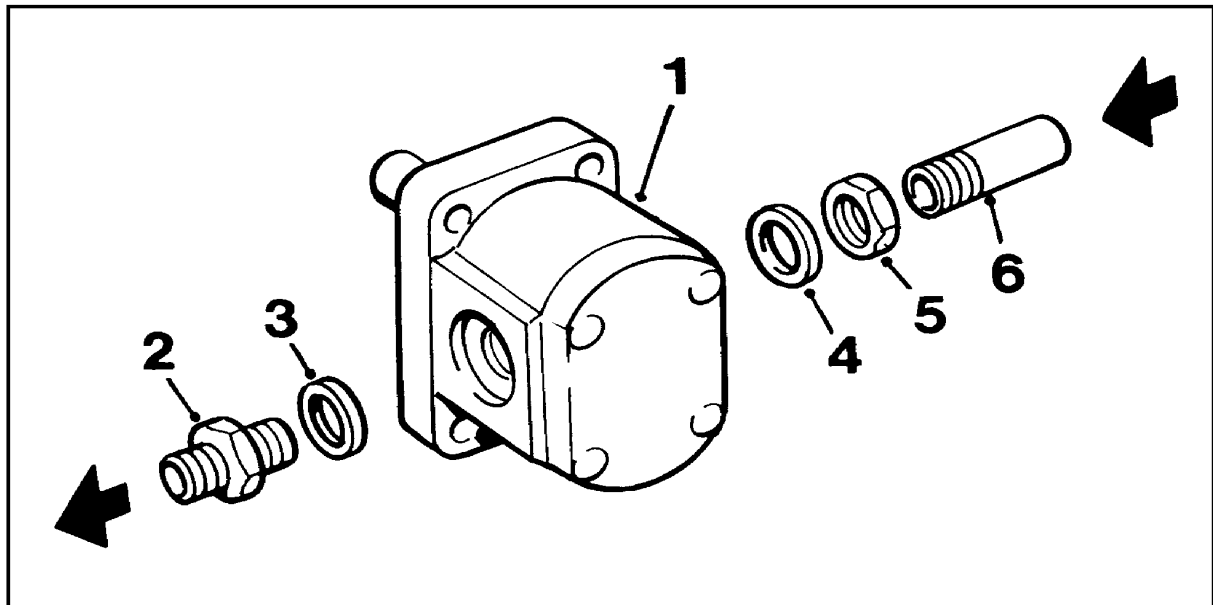

Item	Part no	Serial no	Description	Qty
------	---------	-----------	-------------	-----

When ordering a hydraulic pump, state whether DOWTY', SUNDSTRAND' or 'ULTRA', as indicated on the pump casing or serial plate.

### Dumpers with Petter PH2 or Lister ST3 engines

1	10535A02		# PUMP, 'DOWTY', Petter PH2	1
1	11041A05		# PUMP, 'SUNDSTRAND', Petter PH2	1
1	10539A02		# PUMP, 'DOWTY', Lister ST3	1
1	11041A02		# PUMP, 'SUNDSTRAND', Lister ST3 # (pumps have 3/4" inlet & 3/4" outlet)	1
2	119S10		ADAPTOR, (outlet)	1
3	100S06		SEAL, bonded	1
4	186S12		SEAL, nylon	1
5	72S03		NUT	1
6	10910A01		PIPE, stub, (inlet)	1

### Dumpers with Lister TS3 engines

10	10539A03		PUMP, 'ULTRA', Lister TS3 (pump has 3/4" inlet & 3/4" outlet)	1
11	119S13		ADAPTOR, (outlet)	1
12	100S06		SEAL, bonded	2
13	100S06		SEAL, bonded	1
14	119S15		ADAPTOR, (inlet)	1
15	V2003053		ELBOW	1
10	11041A03		\$ PUMP, 'SUNDSTRAND', Lister TS3 (pump has 3/4" inlet & 1/2" outlet) \$ <b>Obsolete: use Kit 10539A04</b>	1
.....	10539A04		KIT, PUMP & FITTINGS Replacement for 11041A03	1
11	122S04		ADAPTOR, (outlet)	1
12	100S04		SEAL, bonded	2
13	100S06		SEAL, bonded	1
14	119S15		ADAPTOR, (inlet)	1
15	V2003053		ELBOW	1

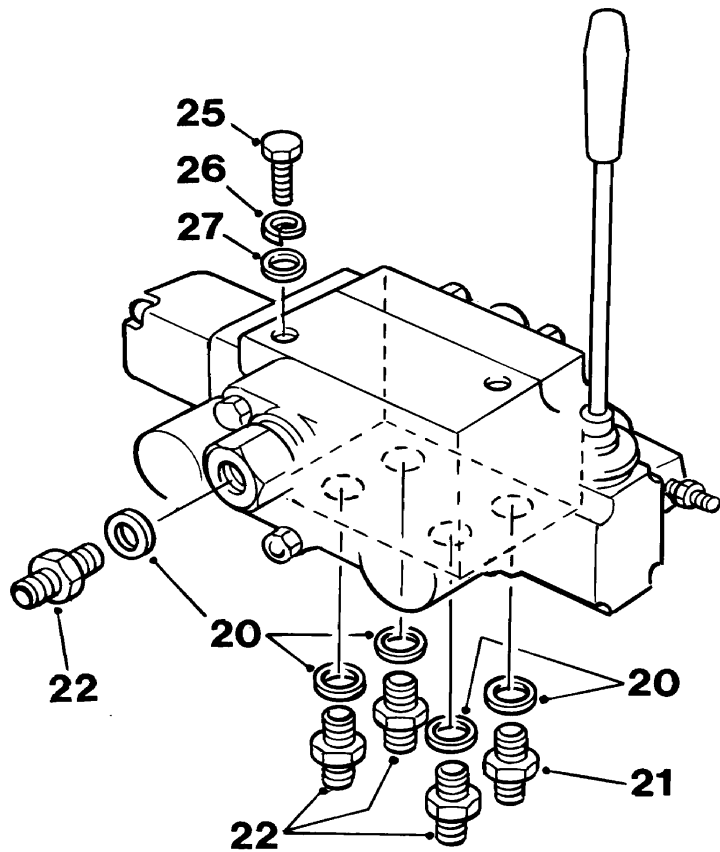
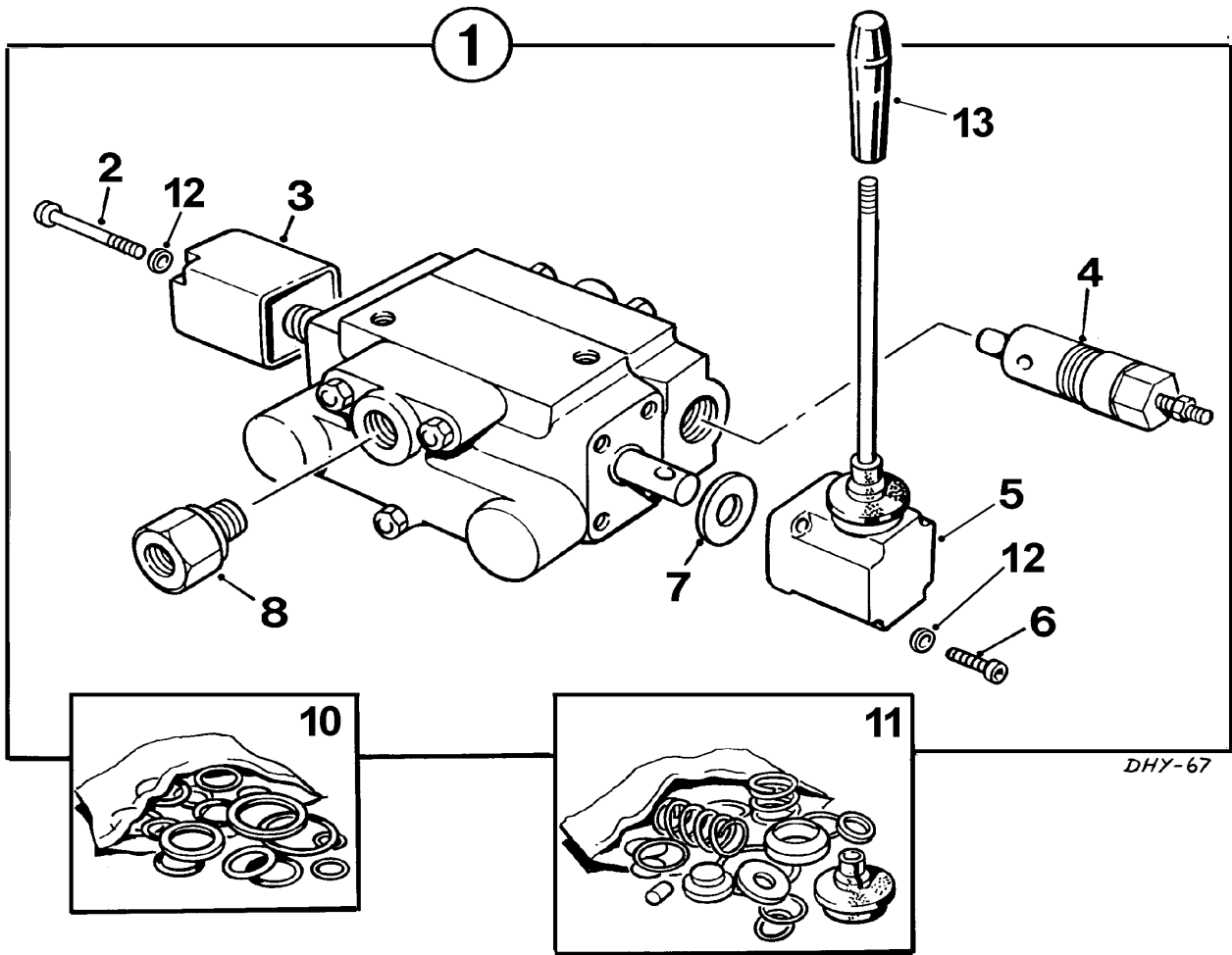



**CONTROL VALVE****7 - B - 1**

<b>Item</b>	<b>Part no</b>	<b>Serial no</b>	<b>Description</b>	<b>Qty</b>
		/ 0329	<b>4B2500</b>	
		/ 0304	<b>4B3000</b>	
1	30322A05		CONTROL VALVE	1
2	30322A0502		SCREW, socket cap head	2
3	30322A0204		CAP, end	1
4	30322A0102		VALVE, relief	1
5	30322A0503		HANDLE, assembly	1
6	68S02B		SCREW, socket cap head	4
7	10S05		SPACER, washer	1
8	30322A0504		ADAPTOR	1
10	451441502		KIT, seals	1
11	30322A0203		KIT, repair	1
12	13S01		WASHER	8
13	30322A0505		KNOB	1
20	100S04		WASHER, bonded	5
21	122S04		ADAPTOR	1
22	119S08		ADAPTOR	4
25	11S03AA		SCREW, set	2
26	267S05		WASHER, flat	2
27	17S04		WASHER, spring	2



**CONTROL VALVE, (sectional)****7 - C - 1**

Item	Part no	Serial no	Description	Qty
		0330 / 0797	<b>4B2500</b>	
		0305 / 0808	<b>4B3000</b>	
1	V2000003		CONTROL VALVE, assembly	1
2	V600017		COVER, inlet	1
4	-		"NOT USED"	
5	100S06		SEAL, bonded	1
6	V2003124		COVER, end	1
7	V600178		KIT, seals	1
8	V600022		VALVE, relief	1
9	V600023		KIT, seals	1
10	V600024		STUD	3
11	9S03		NUT	3
12	41S05		WASHER, spring	3
13	-		SECTION, valve (see page 7 - C - 2)	
14	451431029		ADAPTOR, carryover	1
14A	451431005		SEAL, 'O' ring	1
22	8S04J		BOLT	3
23	17S05		WASHER, spring	3
24	7S04		NUT	3
<b>4B2500</b>				
25	119S13		ADAPTOR, to check v. (illustrated)	1
25	119S10	/ 0784	ADAPTOR, supply hose (not illustrated)	1
25	119S13	0785 /	ADAPTOR, supply hose (not illustrated)	1
<b>4B3000</b>				
25	119S13		ADAPTOR, to check v. (illustrated)	1
25	119S10	/ 0789	ADAPTOR, supply hose (not illustrated)	1
25	119S13	0790 /	ADAPTOR, supply hose (not illustrated)	1
26	100S06		SEAL, bonded	2
27	119S08		ADAPTOR	2
27A	119S08		ADAPTOR	1
28	100S04		SEAL, bonded	2
28A	100S04		SEAL, bonded	1

1A

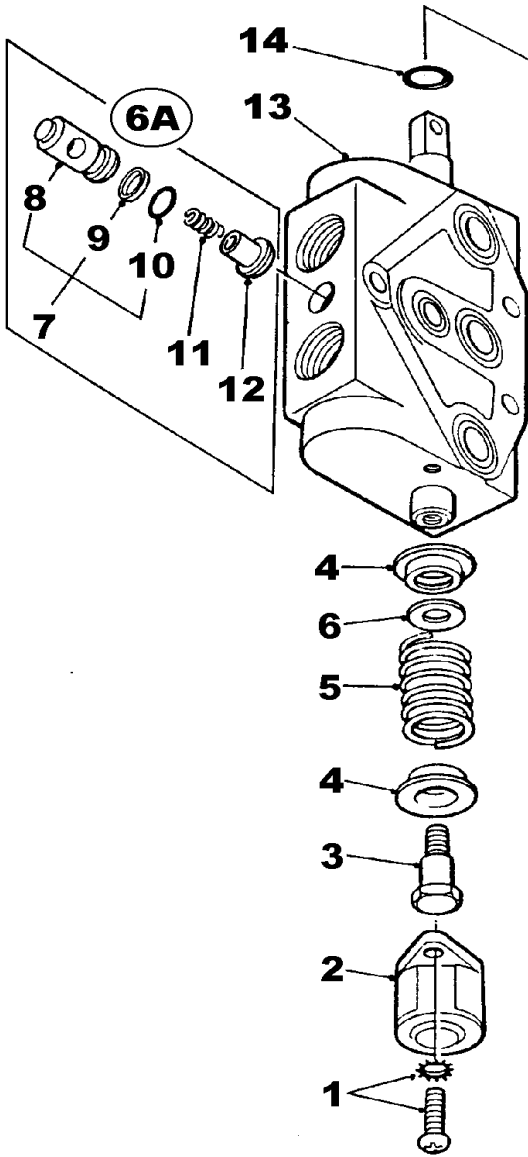

14A

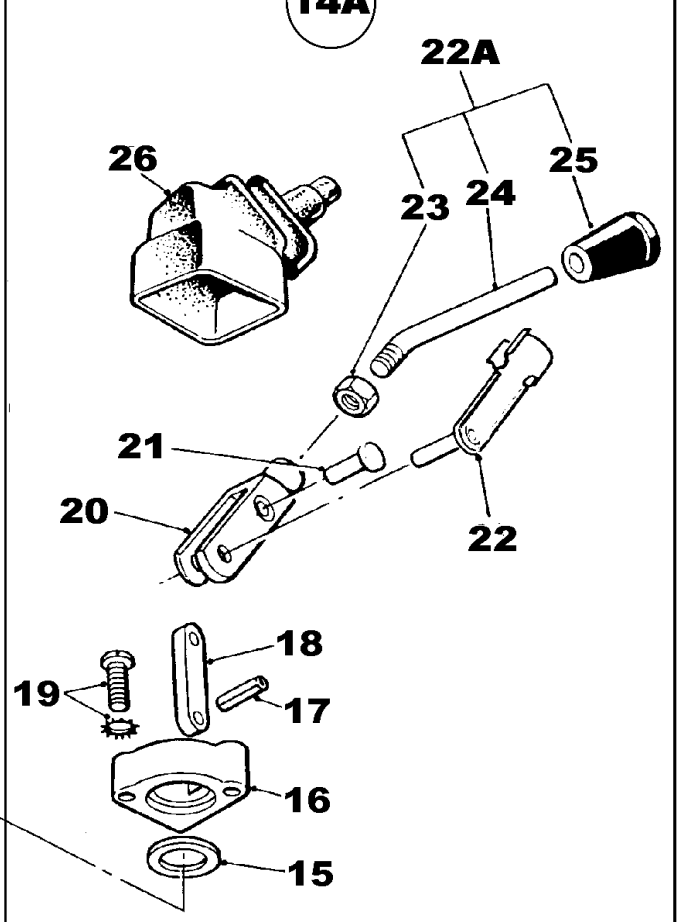

14B

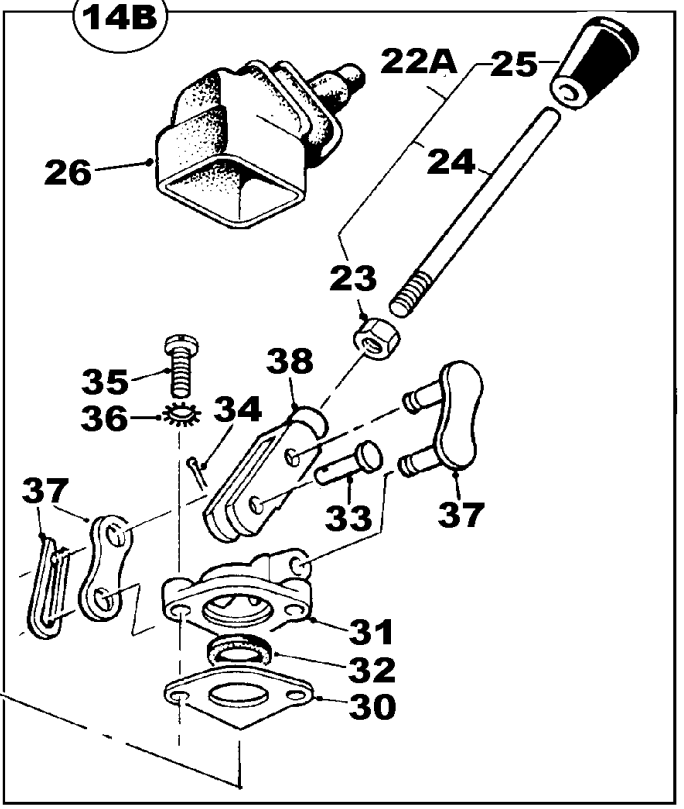

DHY-15

## SECTION, control valve

7 - C - 2

Item	Part no	Serial no	Description	Qty
1A	V600025	0330 / 0797	SECTION c/w handle, <b>4B2500</b>	1
1A	V600025	0305 / 0808	SECTION c/w handle, <b>4B3000</b>	1
1	V600026		SCREW, c/w washer	2
2	V600190		CAP, end	1
3	V2003115		SCREW, shoulder	1
4	V2003117		SEAT, spring	2
5	V2003114		SPRING	1
6	V600179		SPACER	1
6A	V600180		CHECK VALVE, assembly	1
7	V600181		KIT, REPAIR, check valve	1
8	V2003118		GUIDE, check valve	1
9	V600182		RING, back up	1
10	V600183		SEAL, 'O' ring	1
11	V2003119		SPRING	1
12	V2003120		POPPET	1
13	V600176		BODY, c/w spool	1
14	V2003113		SEAL, 'O' ring	2
14A	V600057	JAN-88/ Oct-93	LEVER, control valve, assembly	1
14B	V602166	OCT-93/	LEVER, control valve, assembly	1
15	V2003122	JAN-88/ Oct-93	SEAL, wiper	1
16	V600059	JAN-88/ Oct-93	BRACKET, handle	1
17	V600060	JAN-88/ Oct-93	PIN, roll	1
18	V600061	JAN-88/ Oct-93	LINK	1
19	V600062	JAN-88/ Oct-93	SCREW, c/w washer	2
20	V600063	JAN-88/ Oct-93	CLEVIS	1
21	V600064	JAN-88/ Oct-93	PIN	1
22	V600065	JAN-88/ Oct-93	PIN, clip	1
22A	V600159		LEVER, assembly	1
23	V600066		NUT	1
24	V602478		HANDLE	1
25	V600068		KNOB	1
26	V600069		GAITER	1
30	V602448	OCT-93/	PLATE, seal	1
31	V602449	OCT-93/	BRACKET	1
32	V2003122	OCT-93/	SEAL, wiper	1
33	V602476	OCT-93/	PIN, clevis	1
34	V602475	OCT-93/	PIN, split	1
35	V602447	OCT-93/	SCREW	2
36	V602446	OCT-93/	WASHER	2
37	81S02	OCT-93/	LINK	1
38	V602477	OCT-93/	CLEVIS	1

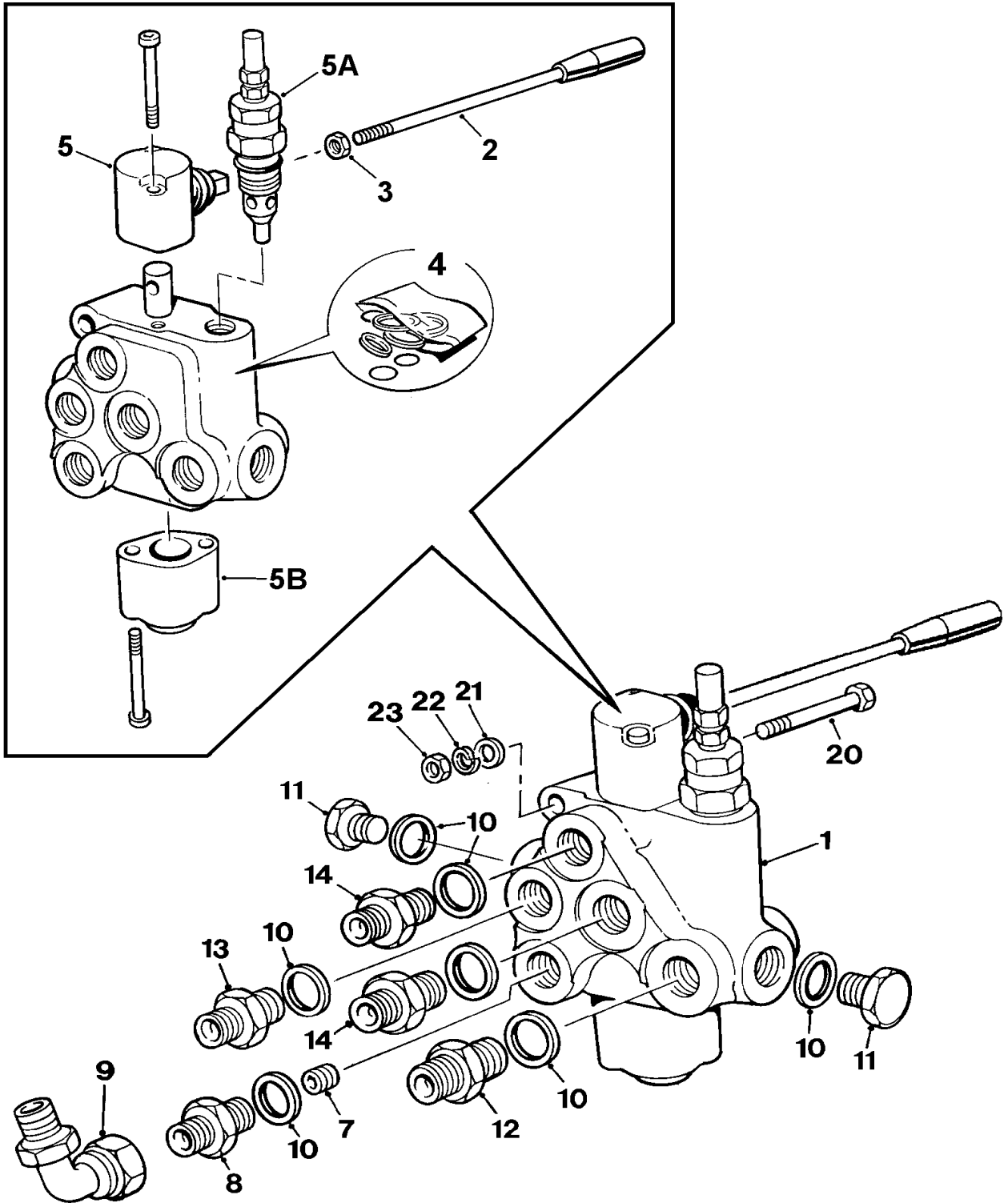

# CONTROL VALVE

7 - C - 3

Item	Part no	Serial no	Description	Qty
		0798 /	<b>4B2500</b>	
		0809 /	<b>4B3000</b>	
1	V2004606		CONTROL VALVE	1
2	V602630		HANDLE	1
3	7S04		NUT	1
4	V602629		KIT, control valve repair	AR
5	V603565		END CAP, lever	1
5A	V603605		VALVE, relief	1
5B	V603606		END CAP, spring base	1
7	V2004607		SCREW, socket head, H.P.C. <i>[Fitted inside valve]</i>	1
8	122S03		ADAPTOR, male/male	1
9	96S09		ELBOW, 90 <sup>o</sup> , male/female <i>[To steer valve hose]</i>	1
10	100S03		SEAL, bonded	7
11	127S03		PLUG	2
12	119S08		ADAPTOR, male/male <i>[Inlet from pump (RED)]</i>	1
13	119S08		ADAPTOR, male/male <i>[To tank (BLUE)]</i>	1
14	122S03		ADAPTOR, male/male <i>[Pressure to cylinder (GREEN)]</i>	2
20	8S03H		BOLT	2
21	267S05		WASHER, flat	2
22	17S04		WASHER, spring	2
23	7S03		NUT	2

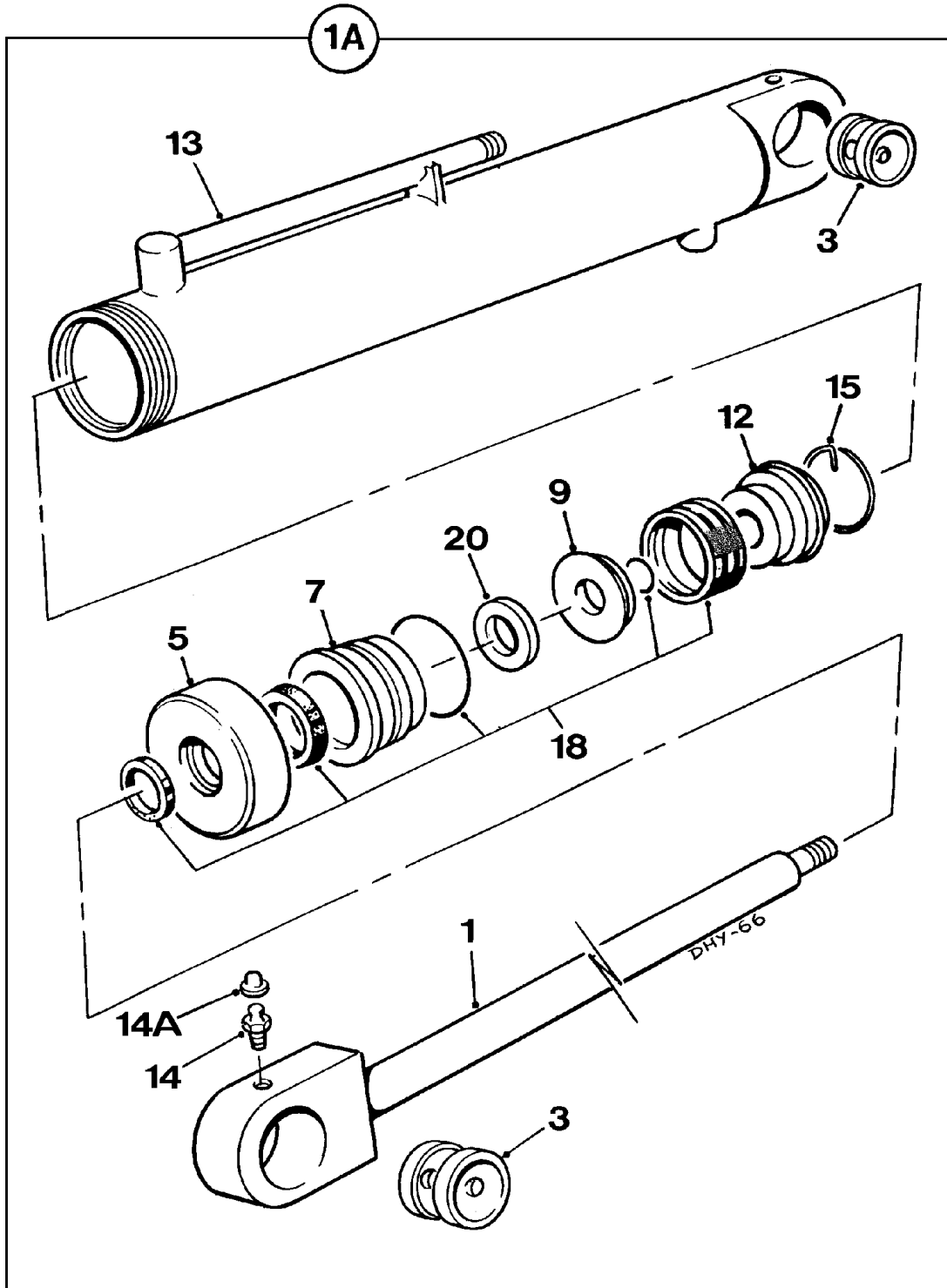
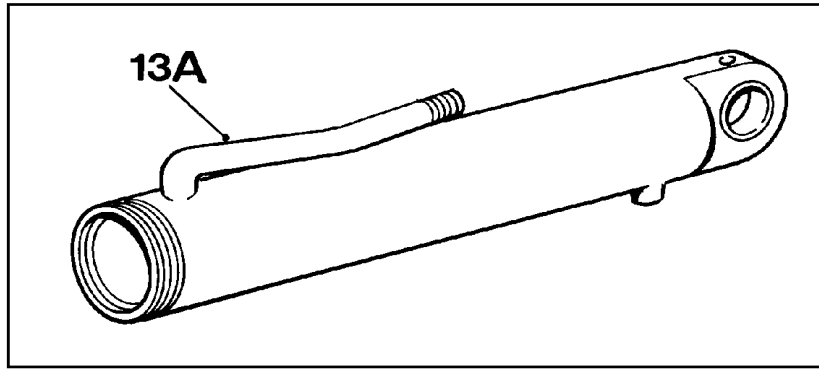



**RAM, tipping: Earth skip**

**7 - R - 1**

<b>Item</b>	<b>Part no</b>	<b>Serial no</b>	<b>Description</b>	<b>Qty</b>
1A	30161A08	/ 600141	# RAM, tipping, assy. <b>4B2500</b>	2
1A	30161A08	/ 600110	# RAM, tipping, assy. <b>4B3000</b>	2
1A	30161A09	600142 / ..... 0803	\$ RAM, tipping, assy. <b>4B2500</b>	2
1A	30161A09	600111 / ..... 0814	\$ RAM, tipping, assy. <b>4B3000</b>	2
1	30161A0802		ROD, ram	1
3	30161A0201		BUSH	2
5	30121A0105		CAP	1
7	30121A0107		SLEEVE	1
9	30121A0109		WASHER, backing	1
12	30121A0112		PISTON	1
13	30161A0801		# CYLINDER, for ram 30161A08	1
13A	30161A0901		\$ CYLINDER, for ram 30161A09	1
14	30162A0102		NIPPLE, grease	2
14A	176S01		CAP, grease nipple	2
15	30121A0115		RING, spring	1
18	CSE 204		KIT, seal	1
20	30161A0902		RESTRICTOR ( <i>install as required</i> )	1

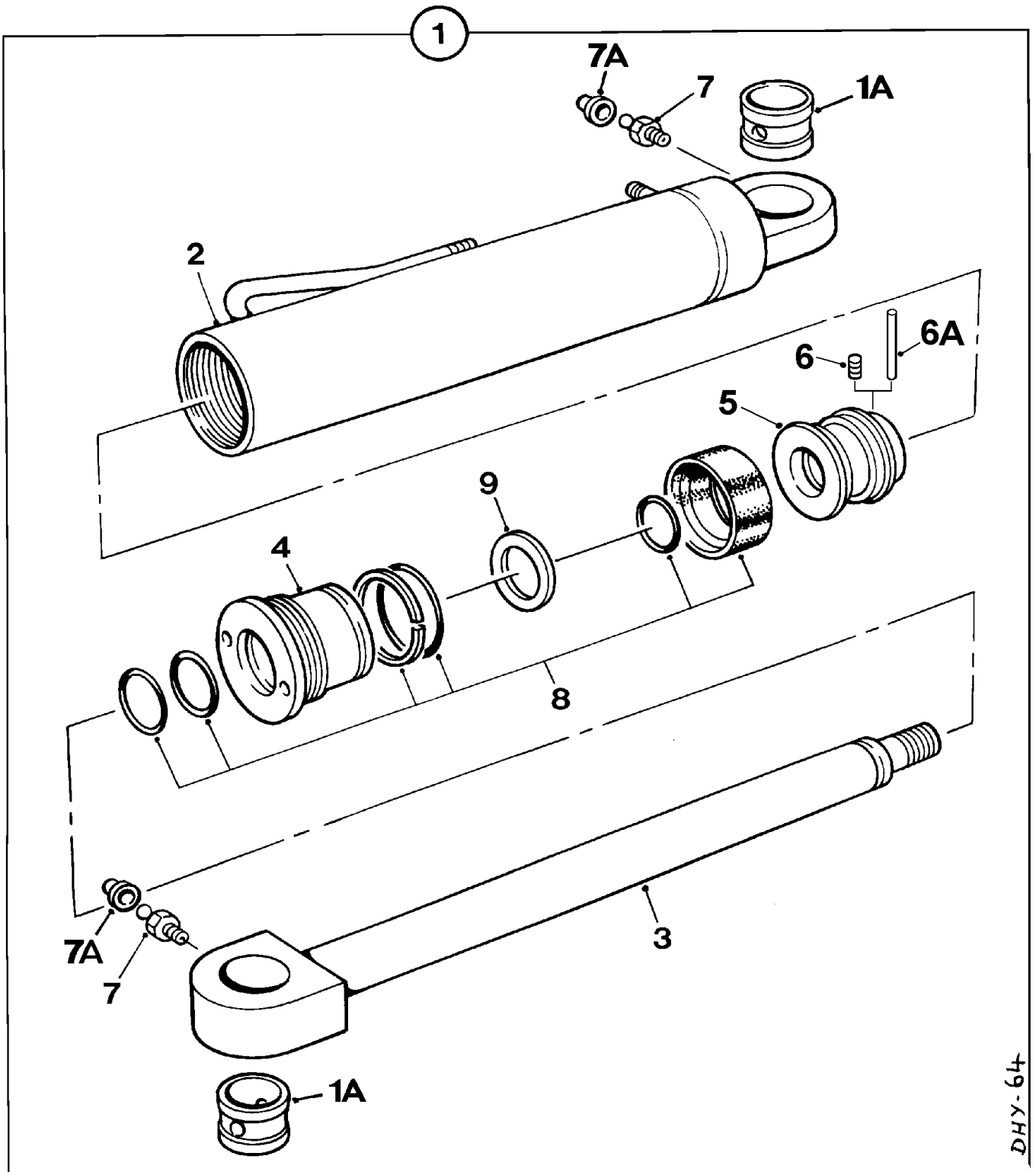

**RAM, tipping: Earth skip**

**7 - R - 1A**

<b>Item</b>	<b>Part no</b>	<b>Serial no</b>	<b>Description</b>	<b>Qty</b>
	<i>From.....</i>	0804 /	<b>4B2500</b>	
		0815 /	<b>4B3000</b>	
1	30161A10		RAM, tipping, assembly	2
1A	30161A0803		BUSH, ram pivot	1
2	30161A1005		CYLINDER, ram	1
3	30161A1004		ROD, piston	1
4	30121A0402		RETAINER (one piece)	1
5	30121A0401		PISTON (one piece)	1
6	57S04D2	/ Oct-99	SCREW, grub	1
6A	54S04N	Oct-99 /	PIN, roll	1
7	131S01		NIPPLE, grease	2
7A	176S01		CAP, grease nipple	2
8	CSE204		KIT, seals	1
9	30161A0902		RESTRICTOR	1

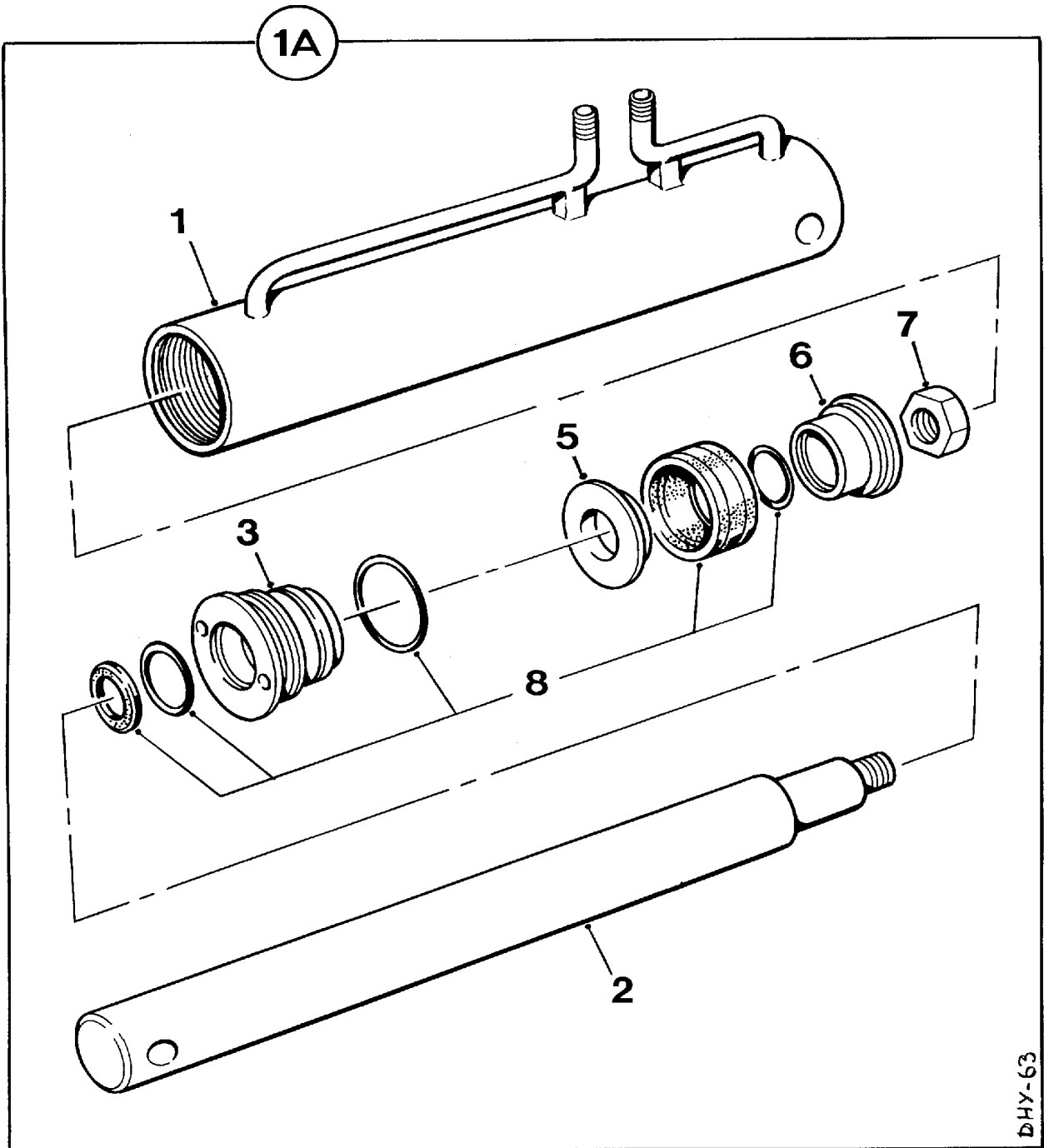

**RAM, tipping: High discharge skip****7 - R - 2**

<b>Item</b>	<b>Part no</b>	<b>Serial no</b>	<b>Description</b>	<b>Qty</b>
1A	30302A01		RAM, assembly	1
1	30302A0101		CYLINDER	1
2	30302A0102		ROD, piston	1
3	30302A0103		RETAINER	1
4	30302A0104		NUT, ring	1
5	30302A0105		PISTON, front	1
6	30302A0106		PISTON, rear	1
7	30302A0107		NUT, locking	1
8	30302A0108		KIT, seal	1

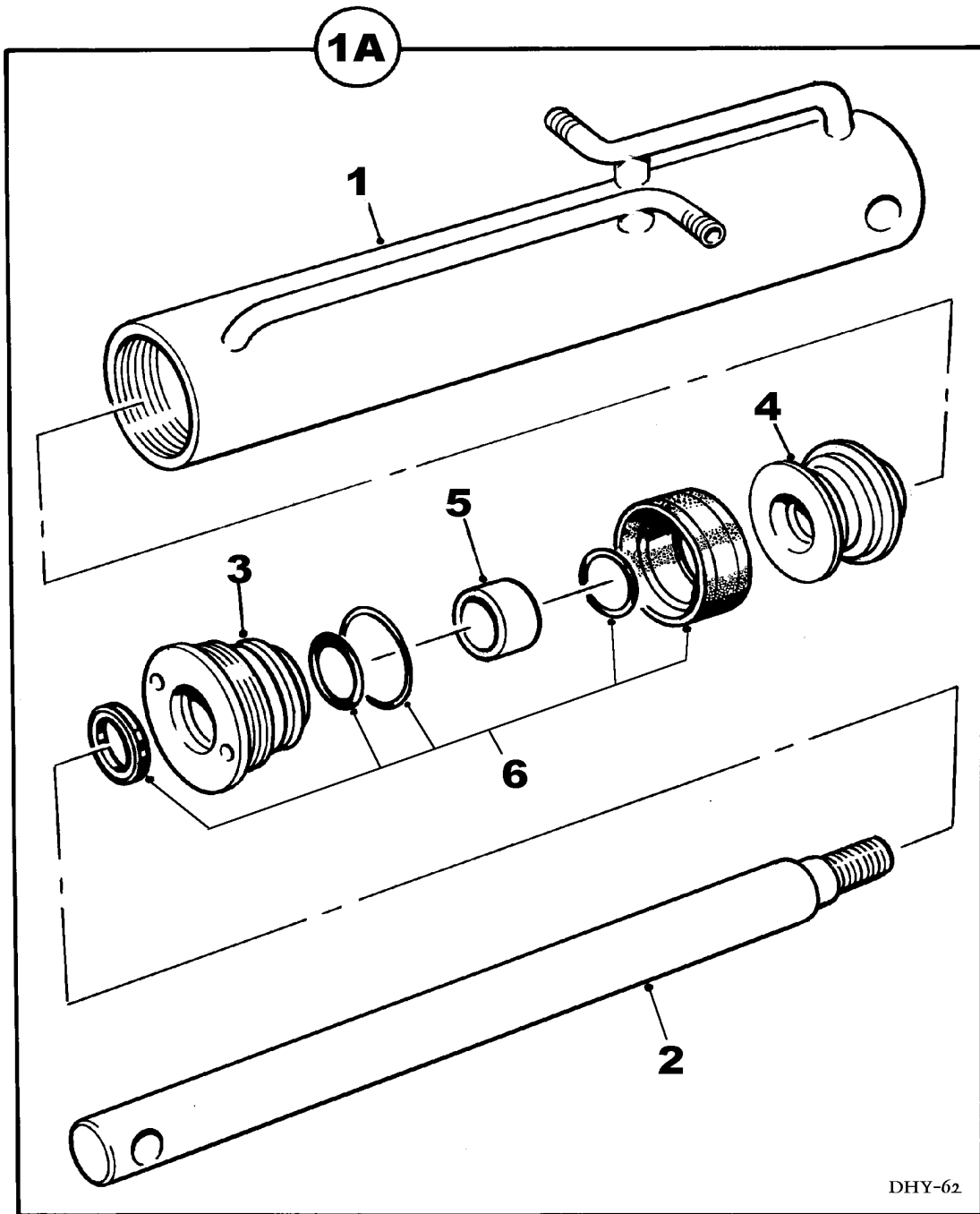

**RAM, tipping: Rotating skip****7 - R - 3**

<b>Item</b>	<b>Part no</b>	<b>Serial no</b>	<b>Description</b>	<b>Qty</b>
1A	30113A05		RAM, assembly	1
1	30113A0501		CYLINDER	1
2	30113A0402		ROD, piston	1
3	30113A0403		RETAINER	1
4	30113A0404		PISTON	1
5	30113A0405		RESTRICTOR	1
6	30113A0406		KIT, seals	1

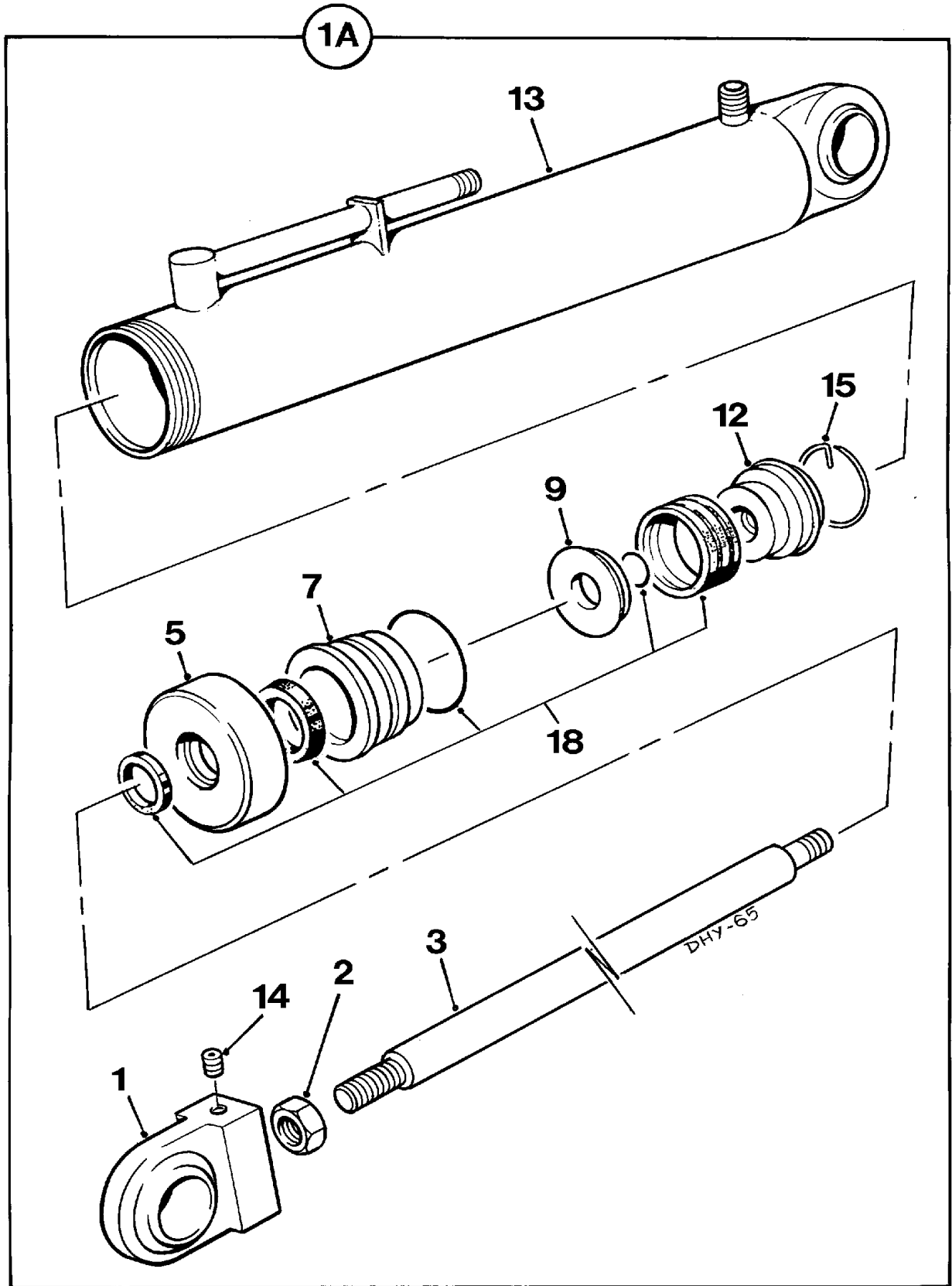



Item	Part no	Serial no	Description	Qty
		/ 0803	<b>4B2500</b>	
		/ 0810	<b>4B3000</b>	
1A	30121A03		RAM, steering, assembly	1
1	20100A02		HEAD	1
2	95S09		NUT, locking	1
3	30121A0302		ROD, ram	1
5	30121A0105		RETAINER	1
7	30121A0303		SLEEVE	1
9	30121A0109		WASHER, backing	1
12	30121A0112		PISTON	1
13	30121A0113		CYLINDER	1
14	30121A0114		SCREW, grub	1
15	30121A0115		RING, spring	1
18	CSE204		KIT, seals	1
...	V2003163		GRUBSCREW (where fitted to lock item 12)	1

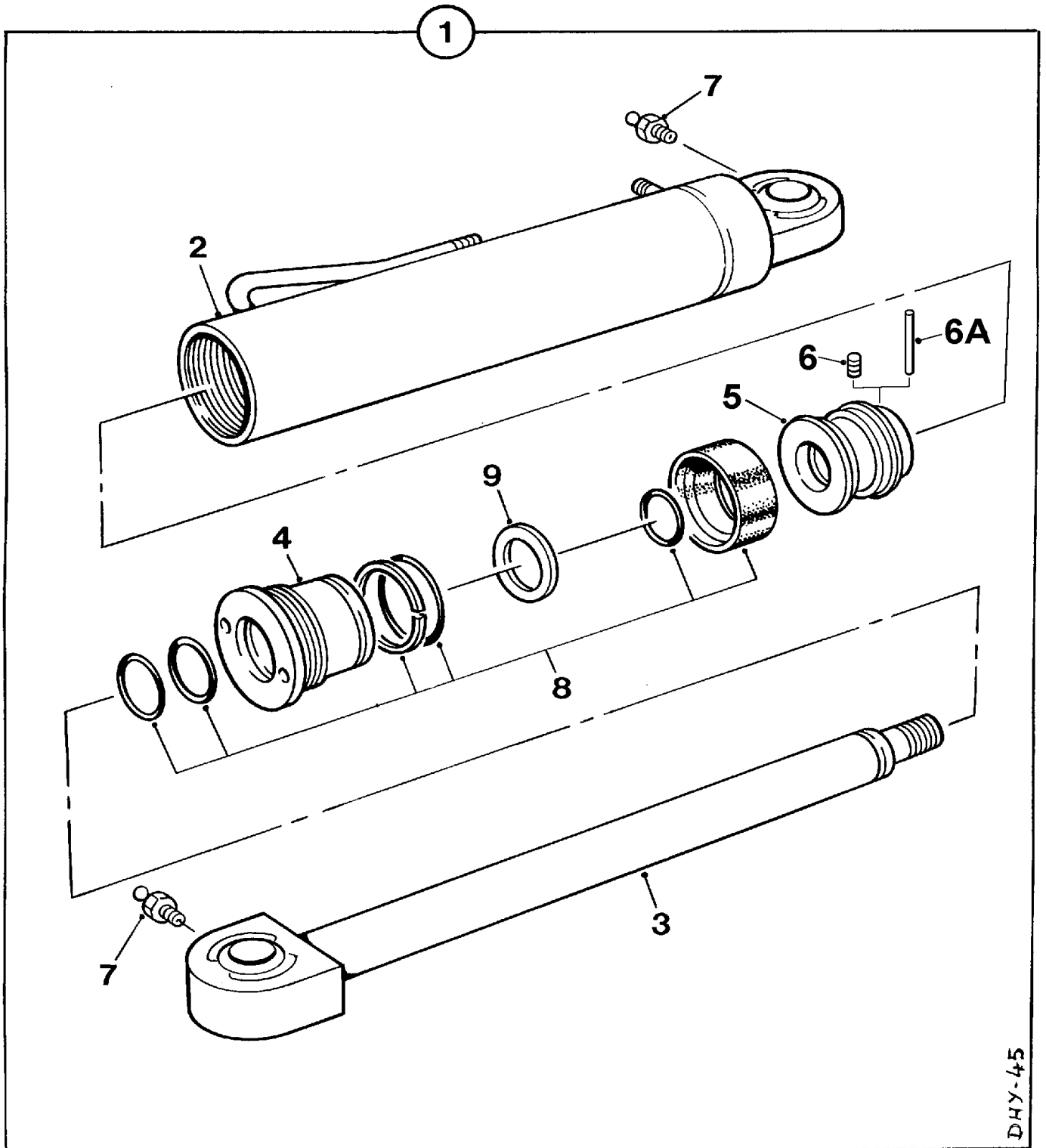

# RAM, steering

7 - R - 5

Item	Part no	Serial no (date)	Description	Qty
		0804 /	<b>4B2500</b>	
		0811 /	<b>4B3000</b>	
1A	30121A04		RAM, steering, assembly	1
2	30121A0405		CYLINDER	1
3	V2002566		ROD, piston	1
4	30121A0402		RETAINER	1
5	30121A0401		PISTON	1
6	57S04D2	/ Oct-99	SCREW, grub	1
6A	54S04N	Oct-99 /	PIN, roll	1
7	131S01		NIPPLE, grease	2
8	CSE204		KIT, seals	kit 1
9	30121A0403		RESTRICTOR	1

***Section***

**8**

# ***CHASSIS & PANELS***

<b>CHASSIS</b>	<b>8 - A - 1</b>
----------------	------------------

---

<b>BATTERY TRAY</b>	<b>8 - A - 2</b>
---------------------	------------------

---

<b>PANELS</b>	<b>8 - B - 1</b>
---------------	------------------

---

<b>R.O.P.S. FRAME</b>	<b>8 - C - 1</b>
-----------------------	------------------

---

<b>SEAT "KAB"</b>	<b>8 - C - 2</b>
-------------------	------------------

---

***< To begining of Parts***

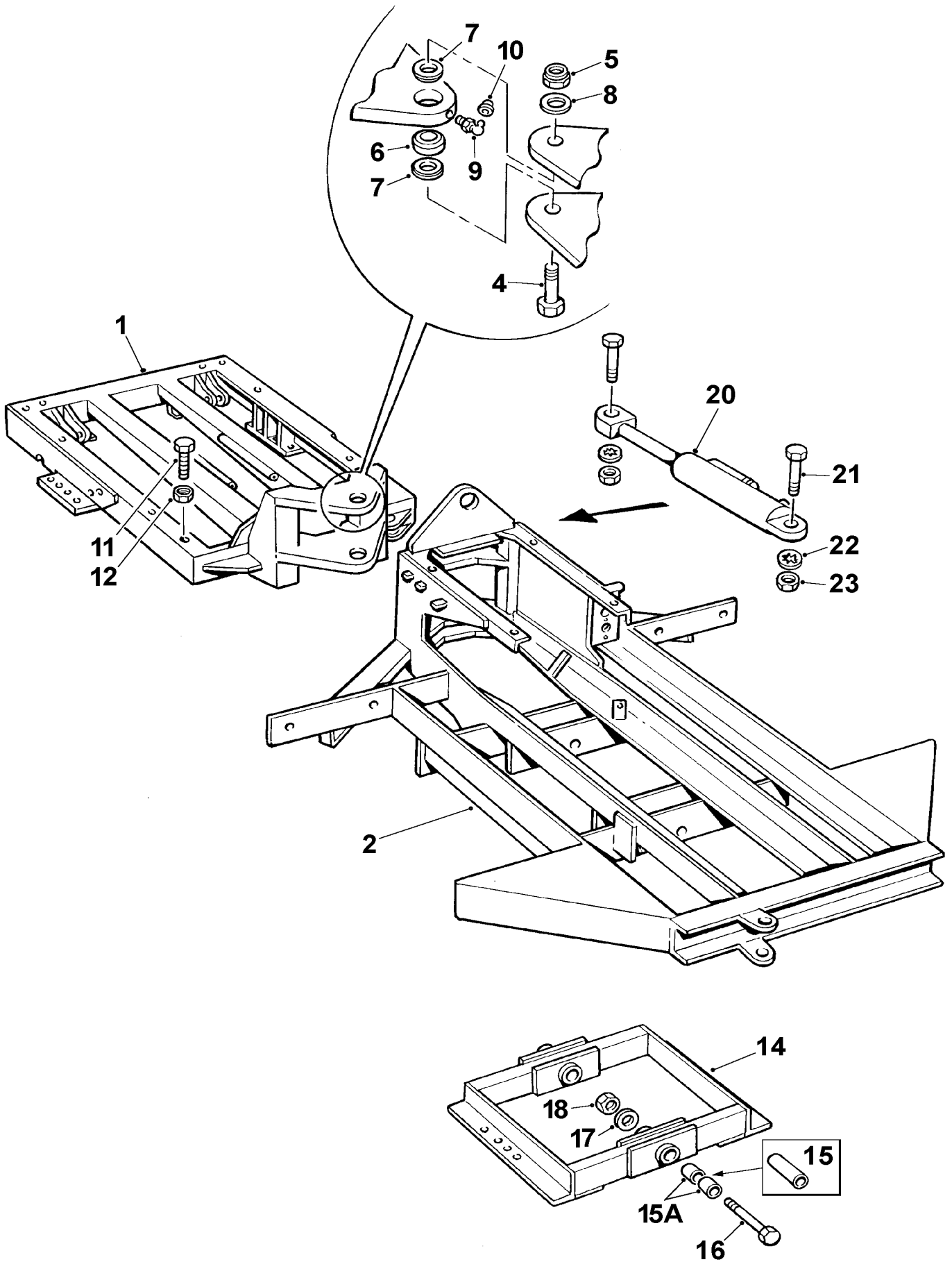

# CHASSIS

8 - A - 1

Item	Part no	Serial no	Description	Qty
<b>4B2500</b>				
1	40100A34	/600174	CHASSIS, front	1
1	40100A39	600175 /	CHASSIS, front	1
2	40076A03		CHASSIS, rear	1
<b>4B3000</b>				
1	40100A35	/ 600158	CHASSIS, front	1
1	40100A39	600159 /	CHASSIS, front	1
2	40076A04		CHASSIS, rear	1
4	10375A07		BOLT	2
5	107S11		NUT	2
6	460214		BEARING	2
7	10609A02		SPACER, tapered	4
8	10S43		WASHER	2
9	131S02		NIPPLE, grease	2
10	176S01		CAP, grease nipple	2
11	11S07P		BOLT, skip support	2
12	7S07		NUT	2
14	30127A01		FRAME, axle pivot, <b>4B2500</b>	1
14	30127A02	/ 600158	FRAME, axle pivot, <b>4B3000</b>	1
14	30127A01	600159 /	FRAME, axle pivot, <b>4B3000</b>	1
15	10588A01	/ Mar 89	# BUSH, pivot (OBSOLETE)	2
15A	V2001647	April 89 /	# BUSH, pivot	4
<p># 10588A01 is obsolete. If a replacement is required for one of 10588A01, then two of V2001647 must be fitted in its place. Because the two items are made of different materials, which vibrate at a different rate, thus affecting wear, it is recommended that both 10588A01 bushes are replaced by four V2001647</p>				
16	8S08S		BOLT	2
17	267S12		WASHER, flat	2
18	61S08		NUT, self-locking	2
20	.....		RAM, steering ( <i>see Hydraulic Section</i> )	1
.....	176S01		CAP, grease nipple ( <i>for steering ram</i> )	2
21	10599A01		BOLT, steering ram	2
22	67S13		WASHER, shakeproof	2
23	10600A01		NUT, steering ram	2

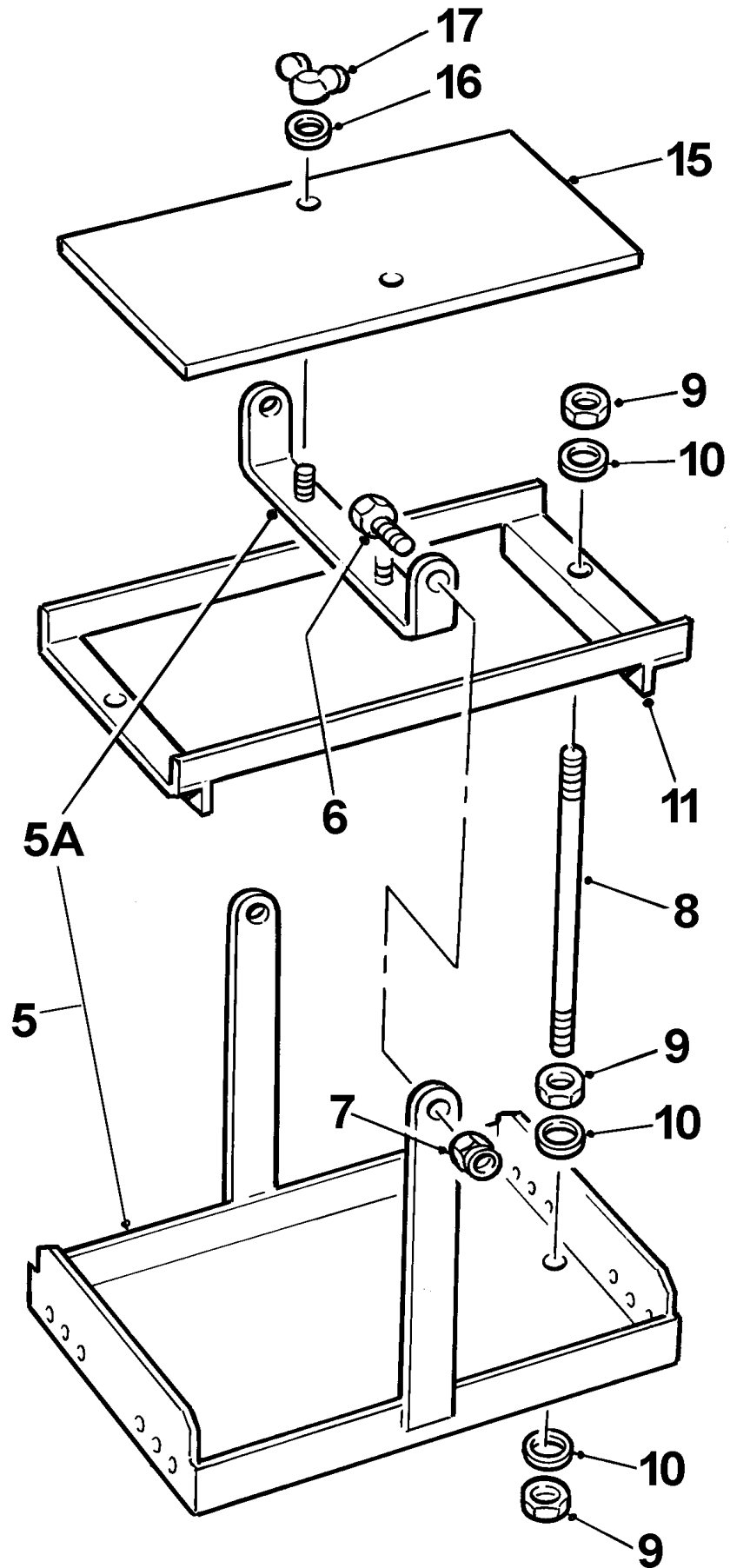



**BATTERY TRAY****8 - A - 2**

<b>Item</b>	<b>Part no</b>	<b>Serial no</b>	<b>Description</b>	<b>Qty</b>
5	30080A03		CARRIER, battery	1
5A	30080A0303		BAR, locking	1
6	11S04C		SCREW, set	2
7	59S03		NUT, 'Nyloc' self-locking	2
8	40SA17		TIE BAR	2
9	9S01		NUT	6
10	267S04		WASHER, flat	6
11	10559A01		CLAMP, battery	1
15	10742A05		COVER, battery	1
16	267S04		WASHER, flat	2
17	177S03		NUT, wing	2

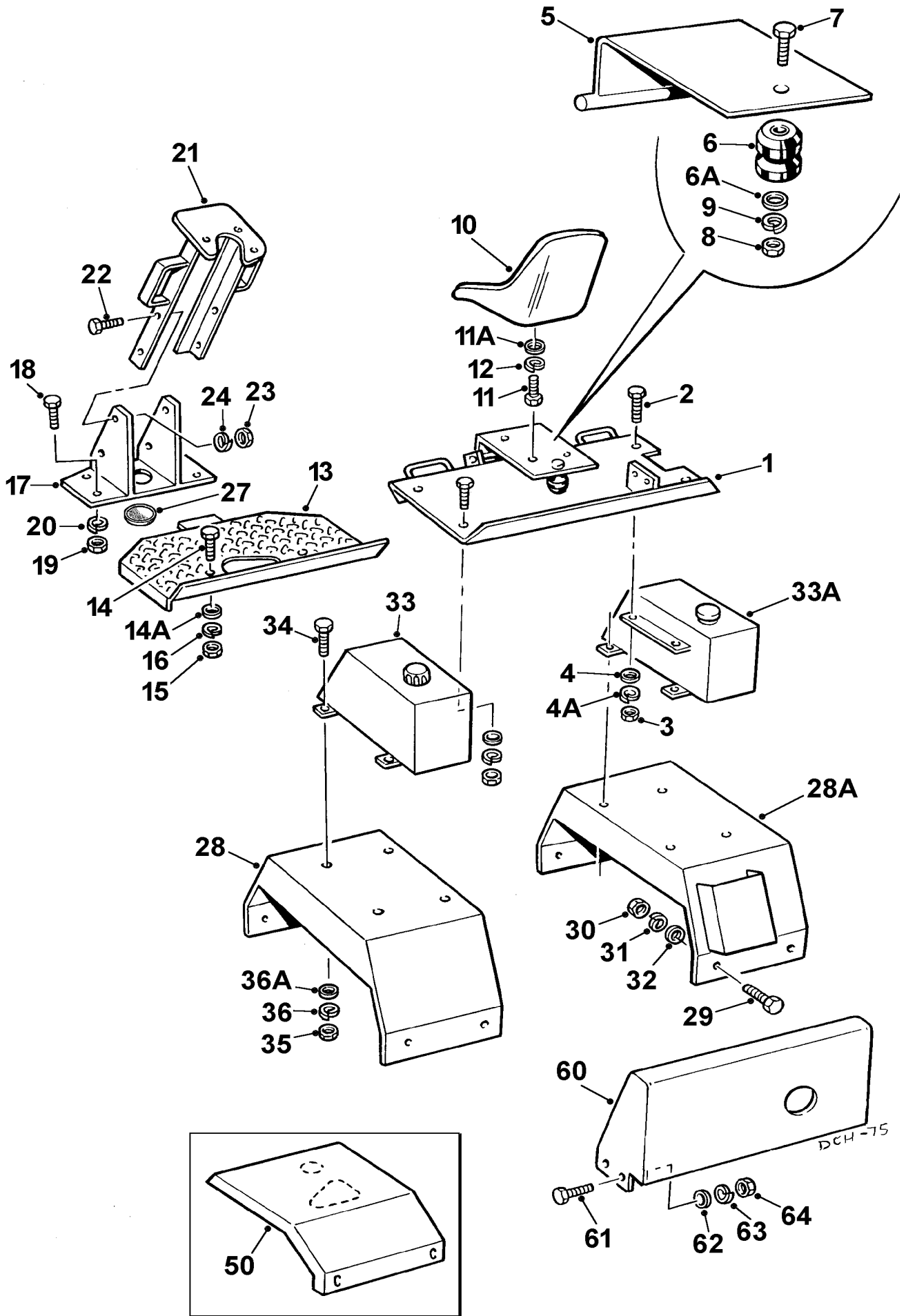

# PANELS

8 - B - 1

Item	Part no	Serial no	Description	Qty
1	30025A13	/ Jan-88	PLATE, seat, Lister engine	1
1	30025A14	/ Jan-88	PLATE, seat, Petter engine	1
1	30025A17	800305/	PLATE, seat support, <b>4B3000</b>	1
1	30025A18	800330/	PLATE, seat support, <b>4B2500</b>	1
2	11S04C		SCREW, set	4
3	7S04		NUT	4
4	267S06		WASHER, flat	4
4A	17S05		WASHER, spring	4
5	30148A04		FRAME, seat, <i>Petter engine</i>	1
5	30148A06		FRAME, seat, <i>Lister TR3 &amp; TS3 eng.</i>	1
6	10519A01		SPRING, rubber	1
6A	C180B		WASHER, flat	1
7	206S03C		SCREW, countersunk	1
8	7S04		NUT	1
9	17S05		WASHER, spring	1
10	20072A01		SEAT ( <i>OBSOLETE: use V2000954</i> )	
10	V2000954		SEAT	
<p><b>Note:</b> When replacing seat 20072A01 with V2000954, refer to Bulletin SB2 (August 1991) for fitting instructions.</p>				
11	11S03B		SCREW	4
11A	267S05		WASHER, flat	4
12	17S04		WASHER, spring	4
13	30163A05		PANEL, floor, <i>Petter engine</i>	1
13	30163A03		PANEL, floor, <i>Lister TR3 &amp; TS3 eng.</i>	1
14	11S04C		SCREW, set	2
14A	267S06		WASHER, flat	2
15	7S04		NUT	2
16	17S05		WASHER, spring	2
17	30184A02		PLATE, mounting	1
18	11S04C		SCREW, set	4
19	7S04		NUT	4
20	17S05		WASHER, spring	4
21	30125A02		SUPPORT, steering column	1
22	11S04C		SCREW, set	4
23	7S04		NUT	4
24	17S05		WASHER, spring	4

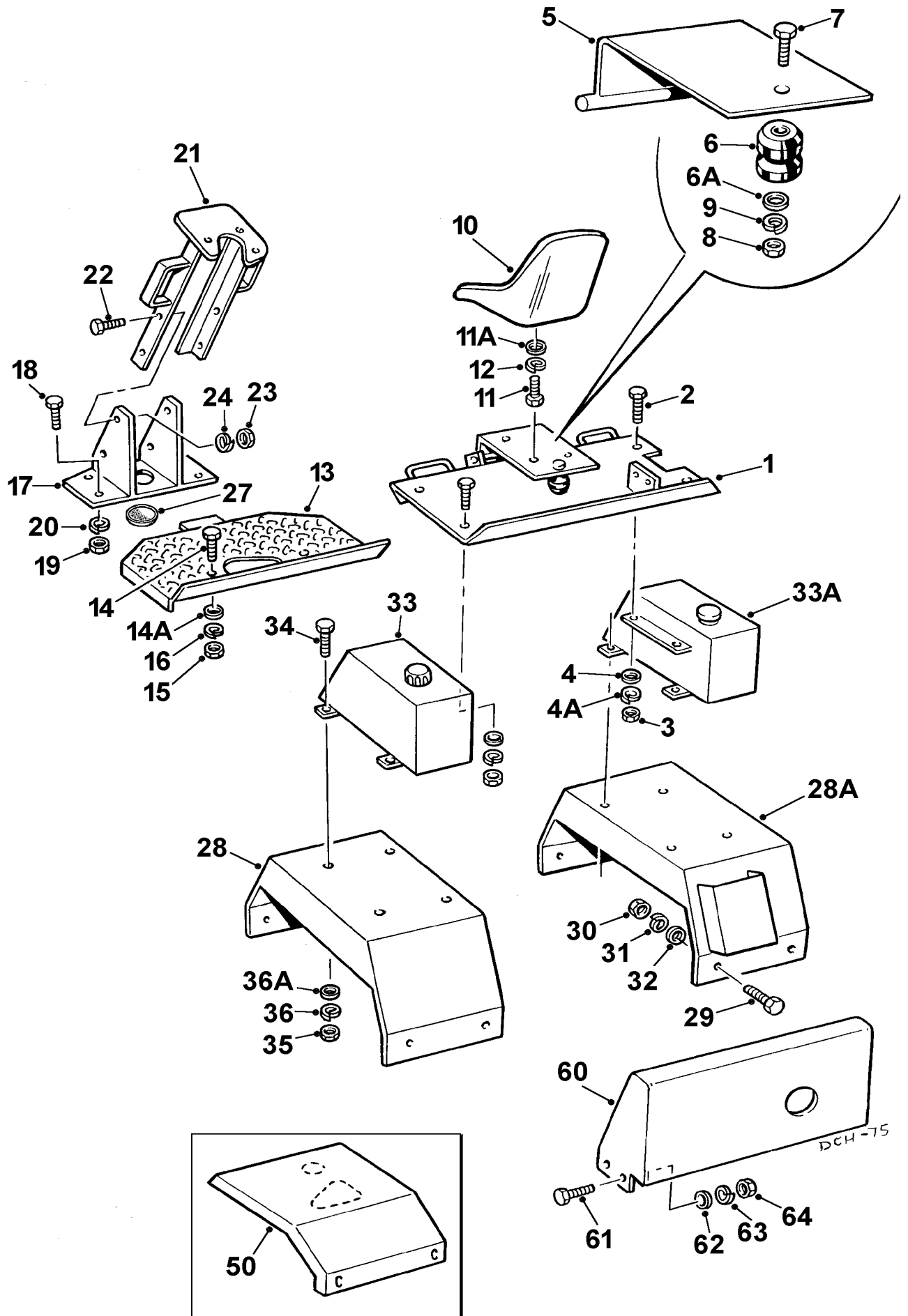

**PANELS**

**8 - B - 1**

Item	Part no	Serial no	Description	Qty
27	435375		GROMMET	1
28	40280A09		MUDWING, L.H. <b>4B2500</b>	1
28	40280A10		MUDWING, L.H. <b>4B3000</b>	1
28A	40279A05		MUDWING, R.H. <b>4B2500</b>	1
28A	40279A03		MUDWING, R.H. <b>4B3000</b>	1
29	11S04C		SCREW, set	8
30	7S04		NUT	8
31	17S05		WASHER, spring	8
32	267S06		WASHER, flat	8
33	.....		TANK, hydraulic ( <i>see page 7 - A - 1</i> )	1
34	11S04C		SCREW, set	4
35	7S04		NUT	4
36	17S05		WASHER, spring	4
33A	.....		TANK, fuel ( <i>see page 3 - C - 1</i> )	1
34	11S04C		SCREW, set	4
35	7S04		NUT	4
36	17S05		WASHER, spring	4
36A	267S06		WASHER, flat	4
50	30063A04		COVER, <i>Petter engine</i>	1
50	30063A02		COVER, <i>Lister ST3 engine</i>	1
.....	11S04C		# SCREW, set	4
.....	7S04		# NUT	4
.....	17S05		# WASHER, spring	4
.....	267S06		# WASHER, flat	4
			# <i>Fittings to retain engine cover (item 50)</i>	
<b>4B2500</b>				
60	40105A06		COVER, rear, <i>Petter engine</i>	1
60	40105A07		COVER, rear, <i>Petter engine (with air cleaner mounting)</i>	1
60	40105A10		COVER, rear, <i>Lister TS3 &amp; TR3 eng.</i>	1
<b>4B3000</b>				
60	40105A10		COVER, rear	1
61	11S04C		SCREW, set	4
62	267S06		WASHER, flat	4
63	17S05		WASHER, spring	4
64	7S04		NUT	4

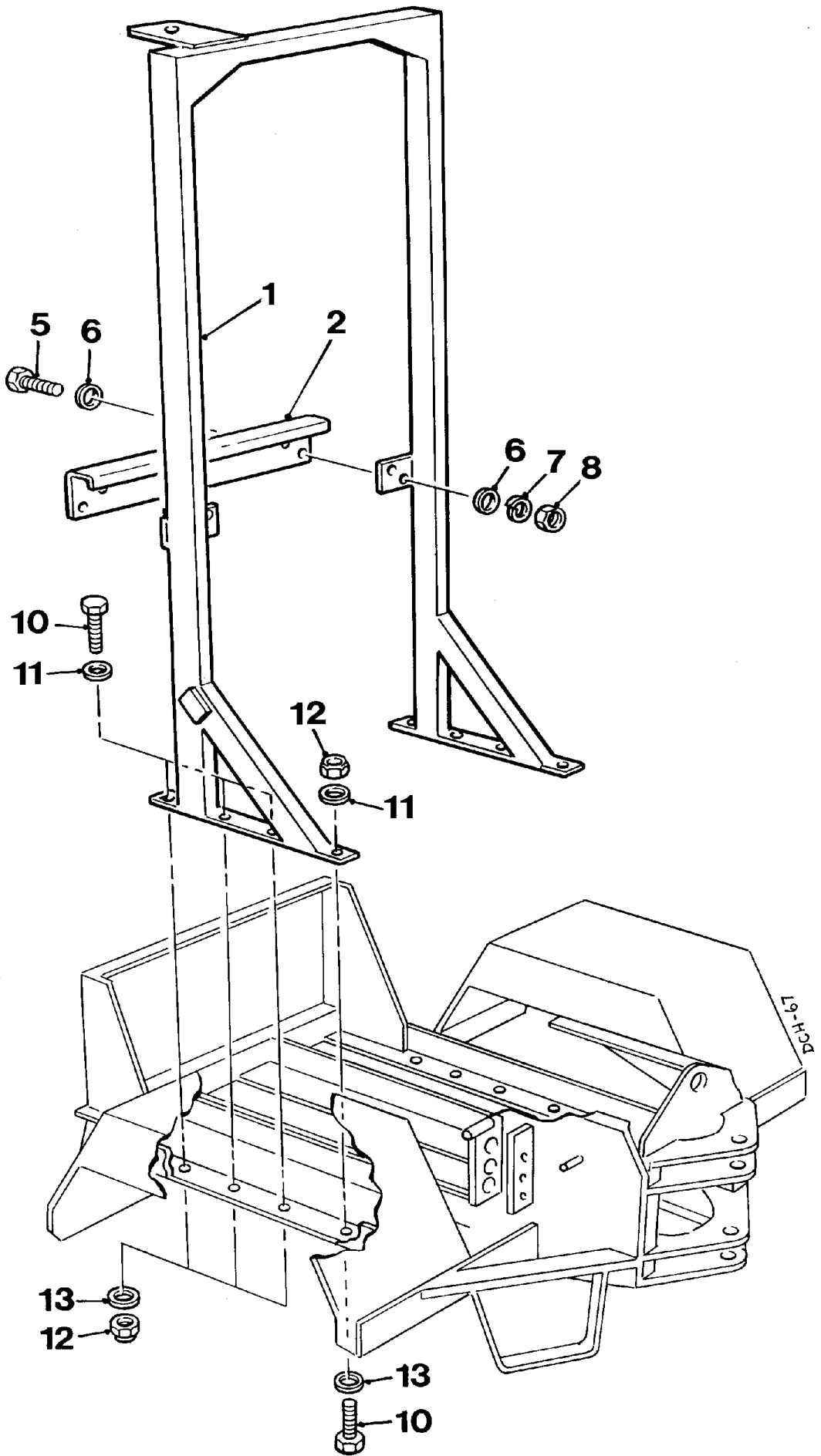

Item	Part no	Serial no	Description	Qty
.....	V602756		ROPS KIT, includes items 1 to 15 listed below. <i>Plus.....</i> Seat assembly KAB XH2/P2N to ISO 6683 <b>V2005013 (see page 8 - C - 2).</b>	
1	V2005026	May-99 /	FRAME (ROPS) c/w stiffener, assy	1
2	V2005029		SUPPORT	1
.....	V2004754		DECAL, damage ( <i>not illustrated</i> )	1
5	11S04C		SCREW, set	4
6	267S06		WASHER, flat	8
7	17S05		WASHER, spring	4
8	7S04		NUT	4
10	11S13H		SCREW, set	8
11	V2003892		WASHER, special	8
12	59S15		NUT, Nyloc	8
13	267S08		WASHER, flat	8
.....	V2005030		PLATE, R.O.P.S. ident. ( <i>not illustrated</i> )	
.....	101S05D		RIVET, pop ( <i>not illustrated</i> )	4

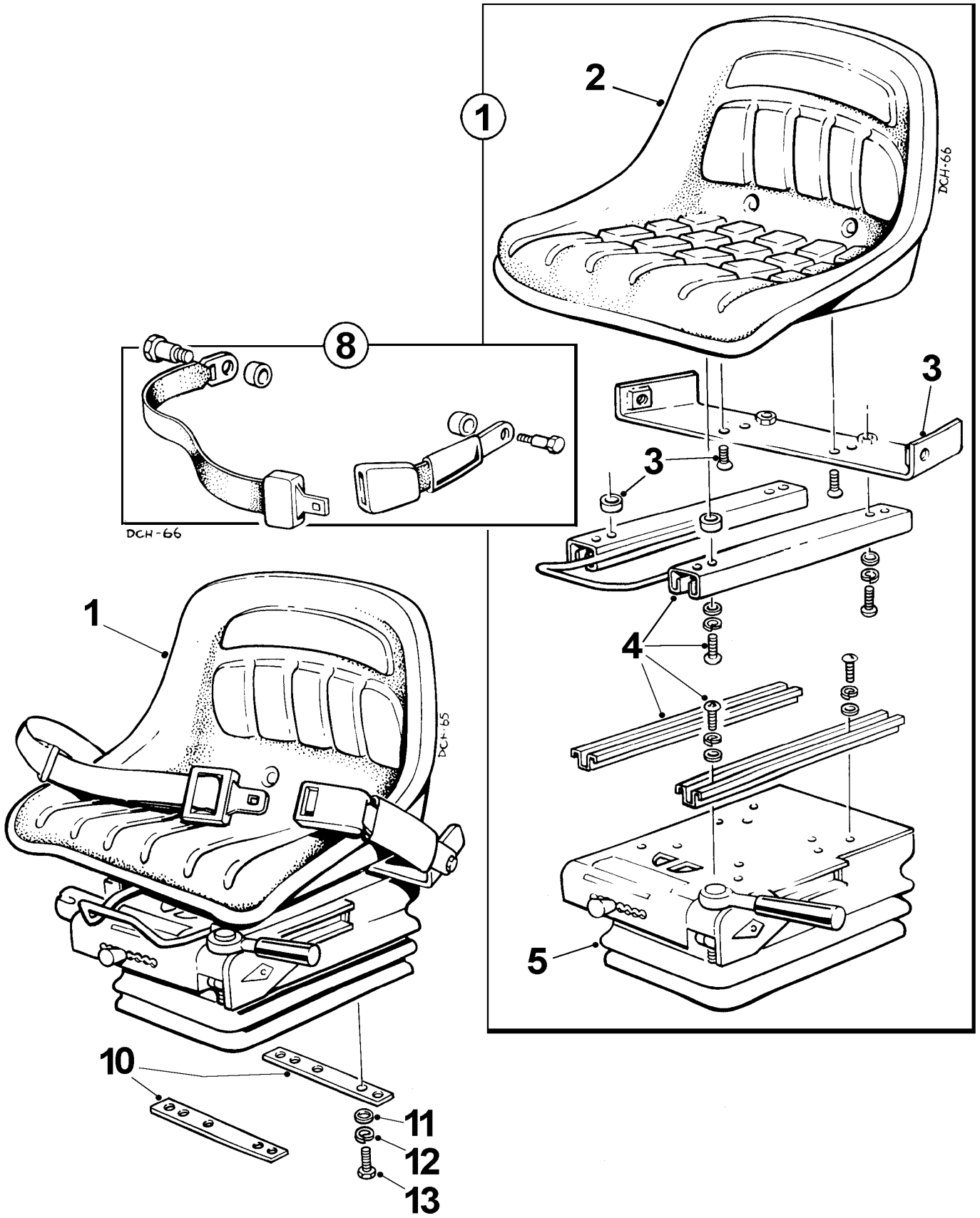



**SEAT, assembly****8 - C - 2****'KAB XH2/P2N' to ISO 6683**

<b>Item</b>	<b>Part no</b>	<b>Serial no</b>	<b>Description</b>	<b>Qty</b>
<b>This seat assembly is used with and is included with R.O.P.S. kit V602756 (see page 8 - C - 1)</b>				
<i>All 4B2500 &amp; 4B3000 dumpers which are fitted with a R.O.P.S. (Roll Over Protective Structure) including 'Export' models must be fitted with this seat assembly.</i>				
<i>Earlier versions of the KAB seating XL or XH suspension unit do not meet the requirements of the ISO 6683 (Seat Belt Pull Test) and should not be used in conjunction with a R.O.P.S.</i>				
1	V2005013	May-99 /	SEAT, assembly c/w with seat belt	1
2	V2000954		SEAT, 'KAB P2N'	
3	V602750		BRACKET, anchorage	1
4	V602752		SLIDE RAIL, assembly	1
5	V602751		UNIT, suspension 'XH2' (ISO 6683)	1
8	V602749		BELT, seat	1
10	V2004206		PLATE, clamp	2
11	267S05		WASHER, flat	4
12	17S04		WASHER, spring	4
13	11S03C		SCREW, set	4

***Section***

**9**

# ***DECALS & PLATES***

**DECALS & PLATES**

**9 - A - 1 to 9 - A - 4**

---

***< To begining of Parts***

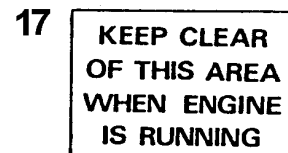
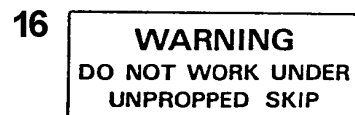
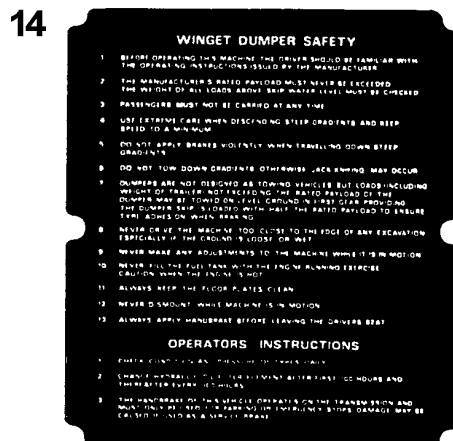
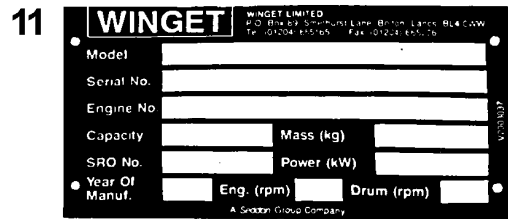
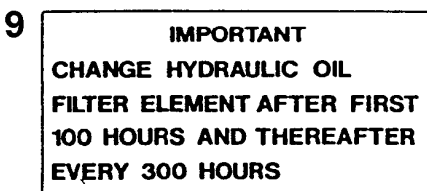
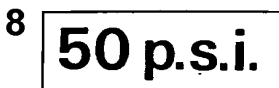
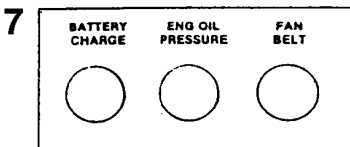
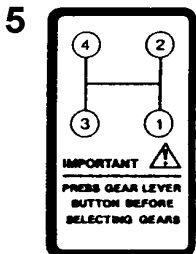
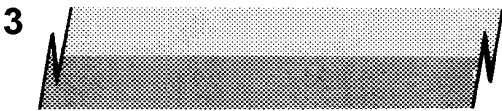
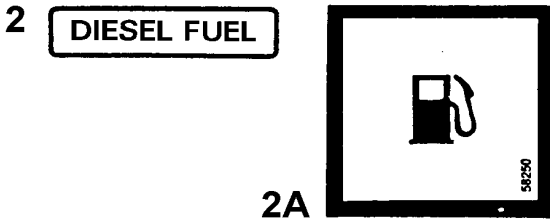
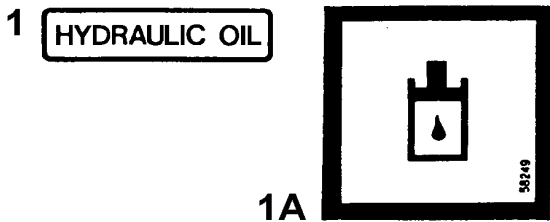

Item	Part no	Serial no	Description	Qty
.....	V601780		KIT, decals, <b>4B2500</b> <i>The kit contains all current decals required for one machine.</i>	
.....	V601263		KIT, decals, <b>4B3000</b> <i>The kit contains all current decals required for one machine.</i>	
1	.....		HYDRAULIC OIL, <i>OBSOLETE: use 1A</i>	
1A	V2003100		HYDRAULIC OIL	
2	.....		DIESEL FUEL, <i>OBSOLETE: use 2A</i>	
2A	V2003101		DIESEL FUEL	
3	V2003038		STRIPE, bodywork, 2 colour	
4	V2003039		WINGET, logo	
5	V2003157		GEAR POSITIONS	
7	V2000348		WARNING LIGHTS	
8	10166A02		50 psi tyre pressure	
9	10215A03		CHANGE HYDRAULIC OIL FILTER	
10	10284A01		DUMP / RETURN	
11	V2003037		PLATE, serial	
.....	101S05D		RIVET (for serial plate)	
12	10536A02		NON FREE-RUNNING LOADS	
13	10541A27		MAXIMUM PAYLOAD 4000KGS	
14	20132A03		PLATE, safety instructions	
.....	101S07E		RIVET (for safety plate)	
15	4602331		NEGATIVE EARTH	
16	DM157		SKIP WARNING	
17	DM198		KEEP CLEAR WARNING	
18	FSE357		ENGINE STOP	



**DECALS & PLATES****9 - A - 2**

<b>Item</b>	<b>Part no</b>	<b>Serial no</b>	<b>Description</b>	<b>Qty</b>
3	DM196		LUBRICATION OIL	
4	V2003155		4B2500	
5	V2003156		4B3000	
6	10540A01		40 psi tyre pressure	
7	V2003142		WARNING - TIGHTEN WHEEL NUTS	
9	10540A02		35 psi tyre pressure	
10	10540A13		MAXIMUM PAYLOAD 2000kgs	
13	V2003143		FLASHING BEACON	
14	DM106		HANDBRAKE WARNING	
15	10541A20		MAXIMUM PAYLOAD 2500kgs	
16	10541A22		MAXIMUM PAYLOAD 3000kgs	
17	V2003598		BRITISH MADE	
18	V2004790		1630kg 4B2500 narrow rotating skip	
19	V2004608		2000kg 4B2500 high discharge skip	
20	10541A17		2245kg 4B2500 wide rotating skip	
21	V2004789		2500kg 4B2500 standard skip	
22	V2004788		3000kg 4B3000 standard skip	

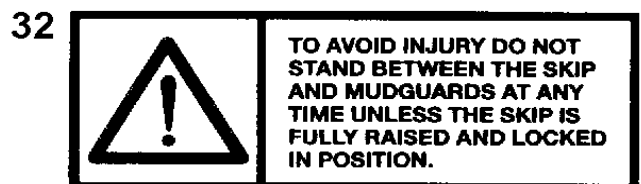
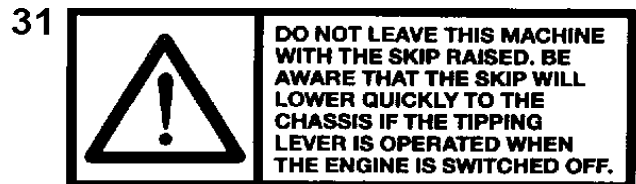
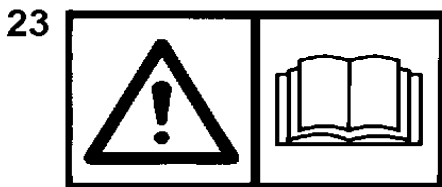
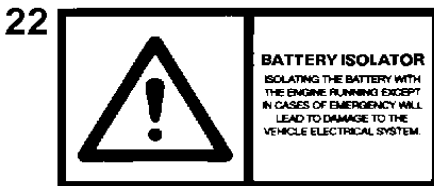
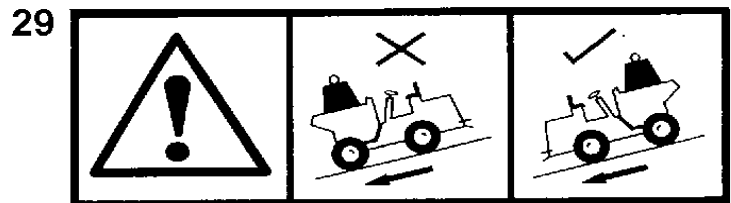
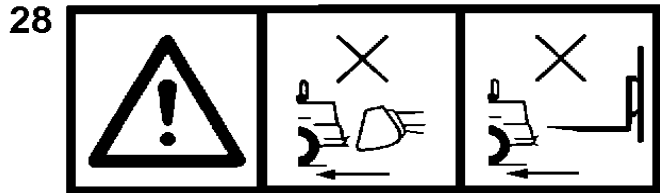
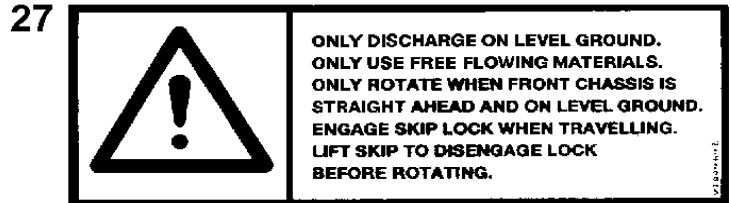
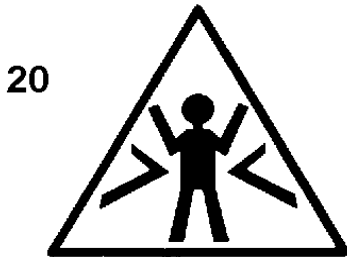
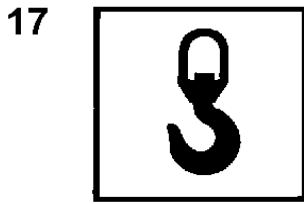



**DECALS & PLATES****9 - A - 3**

<b>Item</b>	<b>Part no</b>	<b>Serial no</b>	<b>Description</b>	<b>Qty</b>
17	V2003665		SLING POINTS	
20	V2004191		CRUSH ZONE	
21	V2004307		ELECTRICAL HAZARD	
22	V2004227		BATTERY ISOLATOR	
23	V2004229		OPERATOR'S HANDBOOK	
24	V2004235		NEGATIVE EARTH	
25	V2004282		HOT SURFACE	
26	V2004288		STARTING HANDLE	
27	V2004642		ROTATING HAZARD	
28	V2004245		NO BUCKETS	
29	V2004450		GRADIENTS	
30	V2004744		EYE PROTECTION	
30A	V2004137		EAR PROTECTION	
31	V2004798		SKIP RAISED	
32	V2004799		TO AVOID INJURY	

1

<h2 style="text-align: center;"><b><u>SAFETY WARNING</u></b></h2>	
1	Before starting this machine, the operator should be familiar with the operating instructions issued by the manufacturer.
2	The manufacturer's rated capacity must never be exceeded.
3	Before carrying out any maintenance, servicing, or greasing, always ensure that the engine has been switched off. Never work on a machine while it is running.
<small>W504694600</small>	

2

	<b>ENSURE HEAPED LOAD DOES NOT RESTRICT FORWARD VISIBILITY</b>
---	--

3

	<b>TIGHTEN SLEW RING BOLTS EVERY WEEK</b>
---	---

4

	<b>ROPS/FOPS STRUCTURE NOT TO BE REPAIRED. IF DAMAGED A REPLACEMENT STRUCTURE MUST BE INSTALLED. ANY UNAUTHORISED MODIFICATION WILL VOID CERTIFICATION AND RESULT IN INJURY.</b>
---	--

5

	<b>TO AVOID DAMAGE TO THE TRANSMISSION AND DRIVE TRAIN BRING MACHINE TO A STANDSTILL BEFORE CHANGING FORWARD OR REVERSE DIRECTION.</b>
---	--

---

<b>Item</b>	<b>Part no</b>	<b>Serial no</b>	<b>Description</b>	<b>Qty</b>
1	504694600		SAFETY WARNING	
2	V2005126		HEAPED LOAD	
3	V2004680		TIGHTEN SLEW RING BOLTS	
4	V2004754		ROPS/FOPS STRUCTURE	
5	V2004748		TRANSMISSION DAMAGE	

## **CALIFORNIA**

### **Proposition 65 Warning**

**Diesel engine exhaust and some of its constituents are known to the state of California to cause cancer, birth defects, and other reproductive harm.**