

WINGET

**OPERATING
INSTRUCTIONS
&
SPARE PARTS
LIST**

**5SHD DIESEL
DUMPER
(CAPACITY 40 CWT)**

ISSUED FEBRUARY 1971

REPRINTED JULY 2002

WINGET LIMITED
PO BOX 41
EDGEFOLD INDUSTRIAL ESTATE
PLODDER LANE
BOLTON
LANCS
BL4 OLS
TEL: ++ 44 (0) 1204 854650
FAX: ++ 44 (0) 1204 854663
service@winget.co.uk
parts@winget.co.uk
winget.co.uk

INTRODUCTION

This Parts & Operators Manual is a re-print of the manual last published in 1971 and contains some amended part numbers.

Health & Safety legislation and working practices applicable to Site Dumpers, both 2 and 4 wheel Drive, Rigid Chassis and Articulated Chassis have changed considerably in the years since this manual was last published and immediately following this Introduction are notes on the Safe Use of Site Dumpers. These notes supersede and replace all previous 'Dumper Safety' notes issued with Winget 5SHD Two Wheel Drive Dumpers

Reference is made on a number of pages to 'bolt c/w nut and washer', this no longer the case, fixings such as nuts, bolts, screws and washers should be ordered as individual items. A number of Whitworth and B.S.F fixings are now no longer available, in these cases the nearest metric equivalent size will be supplied.

The contents of this manual although correct at the time of publication, may be subject to alteration by the manufacturers without notice and Winget Limited can accept no responsibility for any errors or omissions contained within the following pages. Nor can we accept any liability whatsoever arising from the use of this manual howsoever caused.

Winget Limited operate a policy of continuous product development. Therefore, some illustrations or text within this publication may differ from your machine.

WINGET LIMITED
PO BOX 41
EDGEFOLD INDUSTRIAL ESTATE
PLODDER LANE
BOLTON
LANCS
BL4 OLS
TEL ++ 44 (0) 1204 854650
FAX ++ 44 (0) 1204 854663
E mail service@winget.co.uk
parts@winget.co.uk
www.winget.co.uk

Safety is the responsibility of all persons working with this machine. Think "safety" at all times. ***Read and remember the contents of this handbook.***

The safe working recommendations for specific tasks are found with the instructions for the relevant operation in this Handbook.

MACHINE MODIFICATION

WARNING Any modifications to the machine will affect its working parameters and safety factors. Refer to the Manufacturers before fitting any non-standard equipment or parts.



The Manufacturers accept no responsibility for any modifications made after the machine has left the factory, unless previously agreed by the Manufacturers in writing; the Manufacturers will accept no liability for damage to property, personnel or the machine if failure is brought about due to such modifications, or fitment of spurious parts.

TRAINING

WARNING Only trained operators should use this machine.



Operators should hold an appropriate full motor vehicle driving licence and undergo both a safety awareness course and a driver training course for Site dumpers run by the C.ITB or equivalent body leading to the award of a CTA.

It is strongly recommended that operators read the H.S.E. publication "Safe Working with Small Dumpers" which is available from government bookshops (HMSO) or from other bookshops quoting the following number ISBN O11 8836935. Another useful publication is British Standard number BS 6264, "Procedure for Operator Training For Earth Moving Machinery" available from the British Standard Institution.

RUNNING-IN

WARNING While a gradual 'running-in' of a new engine is not necessary, it is extremely important that the instructions given in *Section 2 "Operation"* on "Running-in a new engine" should be followed very closely during the first fifty hours of operation.



DRIVING

WARNING **NEVER** use the machine for purposes other than those for which it was designed. This machine was designed to carry loads such as soil, clay, sand, wet concrete, stone or other similar materials. It was not designed to carry loads which may move around in the skip uncontrollably, nor to carry any loads or materials which overhang the skip in any way. If in any doubt as to the suitability of this machine for a particular task, contact your nearest Distributor or the Manufacturer for advice.



ALWAYS be aware of local and national regulations governing the use of the machine.

NEVER commence work with the machine until the "Daily (or every ten hours)" service checks have been made. (*See Service Section* for details)

ALWAYS check wheel nut tightness daily.

NEVER carry passengers.

Ensure that the seat is securely fixed to the machine. Where seat belt restraints are fitted as part of Rops/Fops protection they must be worn. Check that the seat belt is in good condition, free from cuts and frayed edges.

ALWAYS remain in the driving seat whenever the engine is running. Never attempt to operate any controls unless seated.

ALWAYS apply the parking brake before leaving the driver's seat.

NEVER dismount with the engine running, and never leave the machine unattended with the key in the starter switch.

When Battery Isolators are fitted they must be activated only when the engine is turned off except in cases of emergency.

Activating a Battery Isolator when the engine is running can result in damage to the electrical components and circuits.

NEVER fill the fuel or hydraulic tanks with the engine running.

ALWAYS drive only on surfaces that are known to be stable.

ALWAYS keep the floor plates and walkways clean.

NEVER drive the machine close to the edge of any excavation. Always use effective wheel stops to prevent the machine running close to the edge. Make sure that the stops are in proportion to the size of the wheels and are set sufficiently far enough back from the edge of any excavation to prevent the weight of the load causing a collapse.

NEVER adjust the tyre pressures in an attempt to improve traction on soft ground or obtain a softer ride on hard ground. Incorrectly adjusted tyres can affect the steering and handling characteristics.

NEVER attempt to free a machine which is 'bogged down' by pushing with the bucket of a backhoe loader, tracked excavator or other similar machine.

NEVER make unnecessary "crash stops" when travelling at speed, especially in forward direction.

NEVER work under an unpropped skip. If the dumper was supplied with a special skip support always ensure that it is used.

SKIPS AND LOADING

WARNING NEVER exceed the rated payload. The weights of all loads above skip water level must be checked.



NEVER remain on the machine when loading the skip with excavators or loaders. Stop the engine, apply the parking brake, dismount, and stand well clear.

ALWAYS ensure that the load is evenly distributed in the skip.

NEVER carry loads or heap materials in such a manner as to affect the forward vision.

ALWAYS take extra care when tipping non free running loads.

NEVER use the skip in a tipped position to bulldoze heaped materials level or to backfill material into excavations.

TOWING

WARNING NEVER attempt to start the engine of a dumper by towing or pushing.



Dumpers are not designed as towing vehicles. However, trailers may be towed provided that:

- 1 The combined weight of the trailer and its load does not exceed the dumper "drawbar pull of 250kg (2500N)" and dumper "drawbar load of 50kg (500N)".
- 2 Trailers may be towed in first gear on level dry ground, provided a purpose made towing pin is used.
- 3 The dumper skip must be loaded with half the rated payload to ensure tyre adhesion when braking.

NEVER tow loads up, down or across gradients.

GRADIENTS

WARNING NEVER operate **Two Wheel Drive rigid chassis dumpers** on any gradients which exceed 10% (1 in 10), or across gradients which exceed 10% (1 in 10).



ALWAYS remember that slippery or loose surface conditions can adversely affect safe machine operation, including braking, particularly on gradients.

ALWAYS choose routes that avoid steep, slippery or loose gradients.

NEVER coast down gradients. Always negotiate gradients in first gear.

ALWAYS drive forwards up gradients when loaded.

ALWAYS reverse down gradients when loaded.

ALWAYS keep the load facing uphill.

NEVER park on a gradient. If this is unavoidable, *ALWAYS* chock the wheels.

NEVER attempt to turn on a gradient

NEVER tow up, down or across a gradient.

NEVER operate high discharge or rotating skips on gradients.

HYDRAULICS

WARNING *ALWAYS* "Dump" residual pressure from the system before leaving the machine or before carrying out any maintenance or adjustments.



If maintenance work requires the skip to be in the raised position, then it must be raised and supported before dumping the pressure.

Dump pressure by switching off the engine, then moving the hydraulic control lever several times in each direction.

NEVER leave the machine unattended with pressure in the system.

ALWAYS purge hydraulic rams before commencing work. With the engine running operate the hydraulic control to fully extend and retract the rams.

ALWAYS practise the greatest cleanliness in maintaining hydraulic components.

SERVICING

WARNING *ALWAYS* report any defect at once, before an accident or consequential damage can occur.



ALWAYS conform to service schedules except where:

- 1 Warning lights or warning indicators call for immediate attention.
- 2 Adverse conditions necessitate more frequent servicing.

ALWAYS wear correctly fitting protective clothing. Loose or baggy clothing can be extremely dangerous when working on running engines or machinery.

ALWAYS, where possible, work on or close to engines or machinery only when they are stopped. If this is not practical, remember to keep tools, test equipment and all parts of your body well away from the moving parts.

ALWAYS "Dump" pressure from the hydraulic system before carrying out any kind of maintenance or adjustment. (**see Service - Hydraulic system**).

ALWAYS avoid contact with exhaust pipes, exhaust manifolds and silencers when the engine is running; these can be very hot.

ALWAYS work out of doors, or in a well-ventilated area.

NEVER run an engine in an enclosed space. Exhaust fumes in enclosed areas can kill.

ALWAYS disconnect battery cables and remove battery before using an external charger, carrying out welding repairs or to prevent unauthorised usage when unattended or during a repair.

NEVER allow unqualified personnel to attempt to repair, remove or replace any part of the machine, or anyone to remove large or heavy components without adequate lifting tackle.

NEVER attempt to modify or repair Rops Frames or Fops Canopies by welding, drilling or any other means. Attempts to do so will invalidate Rops/Fops Certification.

ALWAYS obtain advice before mixing oils; some are incompatible. If in doubt drain and refill.

NEVER allow oils and fuels to come into regular contact with skin. This can lead to serious skin diseases including, medical evidence suggests, skin cancer. *ALWAYS* wear protective gloves when handling oils and fuels whether topping up, draining or refilling. *ALWAYS* wash hands if oils or fuels come into contact with the skin.

Many liquids used in this machine are harmful if taken internally or splashed into the eyes. In the event of accidentally swallowing oils, fuels, anti-freeze, battery acid etc, *DO NOT* encourage vomiting, seek qualified medical assistance immediately.

ALWAYS dispose of waste oils and fuels into waste oil storage tanks. If storage tanks are not available consult your distributor or local authority for addresses of local designated disposal points. It is illegal to dispose of waste oil into drains or water courses or to bury it.

Equipment which includes friction materials will sometimes contain asbestos. When removing friction material dust from components, such as when servicing brakes or clutches, do not blow out with an airline; it could be harmful to inhale the dust. Remove the dust with a vacuum cleaner or wipe clean with a damp rag. Waste should be placed in a sealed container, marked, and disposed of in accordance with local or national regulations.

The accumulated dust found in clutch housings may contain lead/antimony. No food should be eaten at a work place contaminated by this dust. Hands must be washed before eating. Do not blow out dust with an airline.

NEVER work under an unpropped skip. ***If the dumper was supplied with a special Skip Support always ensure that it is used.***

ALWAYS ensure that when using a starting handle that it is clean and in good condition. Keep the engine starting dog and the part of the starting handle that mates with it lightly lubricated (*Refer to the Engine Handbook*).

PREPARATION FOR USE

Fig. 1
BEFORE THE DUMPER IS PUT INTO SERVICE, ALWAYS CHECK THE FOLLOWING POINTS.

1. **Engine**
Check the oil level on the dipstick (A), topping up if necessary to the full mark. See also 'Recommended Oils' page 14.
2. **Gearbox**
Check the oil level on the dipstick (B), topping up if necessary to the full mark. See also 'Recommended Oils', page 14.
3. **Drive Axle**
Remove level/filler plug (C) and check that oil is up to bottom of hole. Top up if necessary. See also 'Recommended Oils', page 14.
4. **Fuel Tank**
Fill tank (D) with diesel oil until approximately 1" from the top.

NOTE: Never allow fuel level to fall to below 2" deep in the bottom of the tank.
5. **Hydraulic Tank**
Fill the hydraulic tank (E). Before removing the cap, clean the surrounding area, to prevent the possible entry of foreign matter. DO NOT MIX OILS. See also 'Recommended Oils', page 14.
6. **Brake System**
Ensure that the brake master cylinder reservoir (F) is full of brake fluid. Top up if necessary, to within 1/4" of the top of the reservoir. Use only Girling Crimson Brake Fluid.
7. **Miscellaneous**
Check wheel nuts for tightness.
Check all nuts and bolts for tightness. Loose nuts and bolts may lead to damage not covered by the Dumper Warranty.

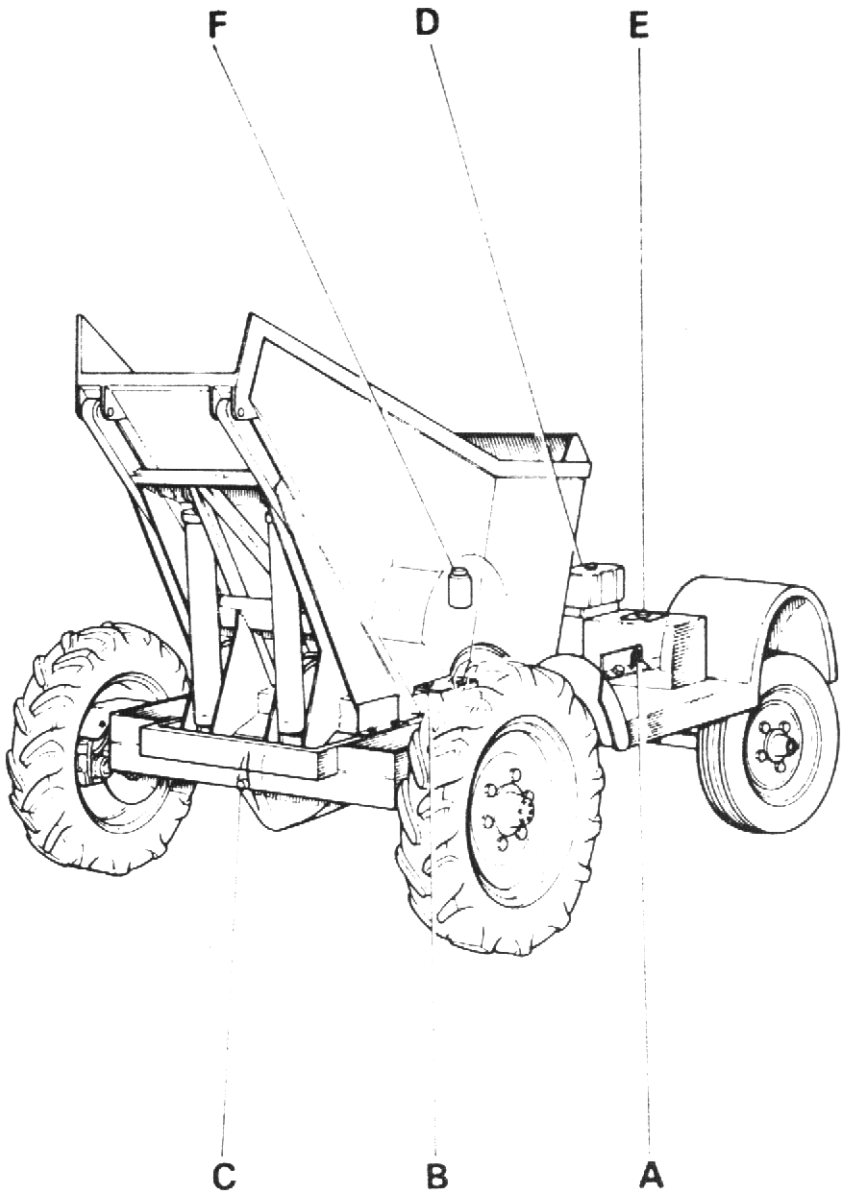

FIG 1

OPERATION

Starting

Fig. 2

1. Lift red-painted overload stop (A) situated on fuel pump immediately above priming lever (B), and move fuel pump racks (C) into fully-open position.
2. Operate priming lever (B) six times.

NOTE: This is unnecessary if engine is already warm.

3. Lift decompression levers (D), positioned on top of engine and turn engine as fast as possible using starting handle. When engine is turning at a good speed, knock down decompression levers and engine should fire.
4. If engine does not fire, lift decompression lever and slowly crank engine a few times before attempting to start again. Where ambient temperature is 5°F (-15°C) or below, a cold starting aid should be fitted.

Stopping

Fig. 2

Hold the fuel pump rack (C) in the fully forward position, or lift the priming lever to the horizontal, until engine stops and then release.

IMPORTANT:

1. DO NOT stop engine by means of decompression levers, this will lead to damaged valve seats and cylinder head joints.
2. DO NOT stop engine by closing fuel tap or by allowing fuel tank to run dry. This will allow air into fuel lines and necessitate bleeding and priming system.

Gear Shift Lever

Fig. 3

The dumper is fitted with three forward gears and one reverse gear. When changing gear, the clutch pedal is used in the normal manner.

Skip Control Lever

Fig. 4

1. Control lever (A) has three positions DUMP (B), HOLD (C) and RETURN (D).
2. Pull lever up to DUMP (B) to deposit load.
3. Push lever down to RETURN (D) to return the skip to the carrying position.

NOTE: If lever is released when the DUMP or RETURN positions, it will automatically return to HOLD (C) position and motion of skip will cease. In this way, speed at which load is deposited can be finely controlled.

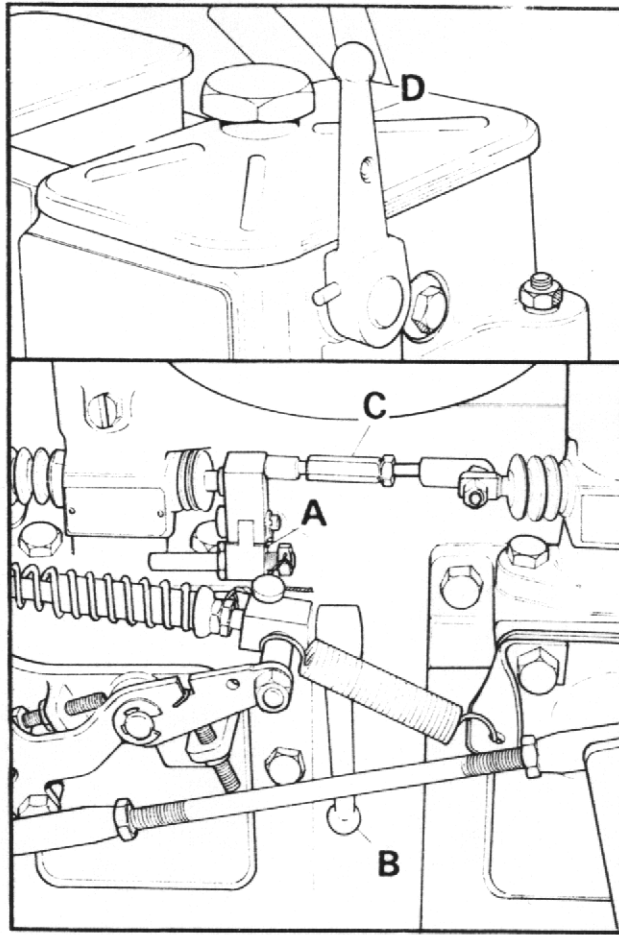

FIG 2

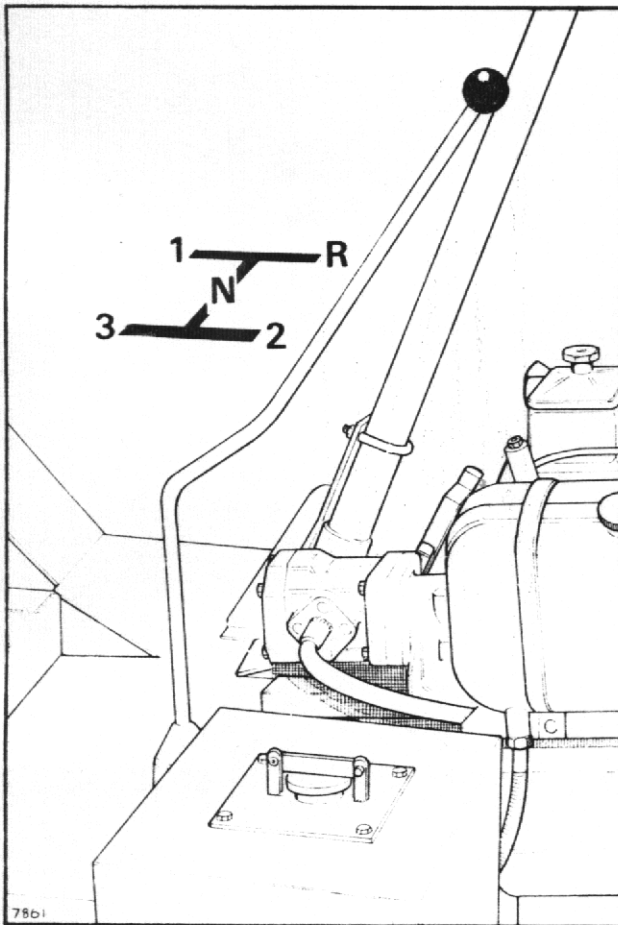

FIG 3

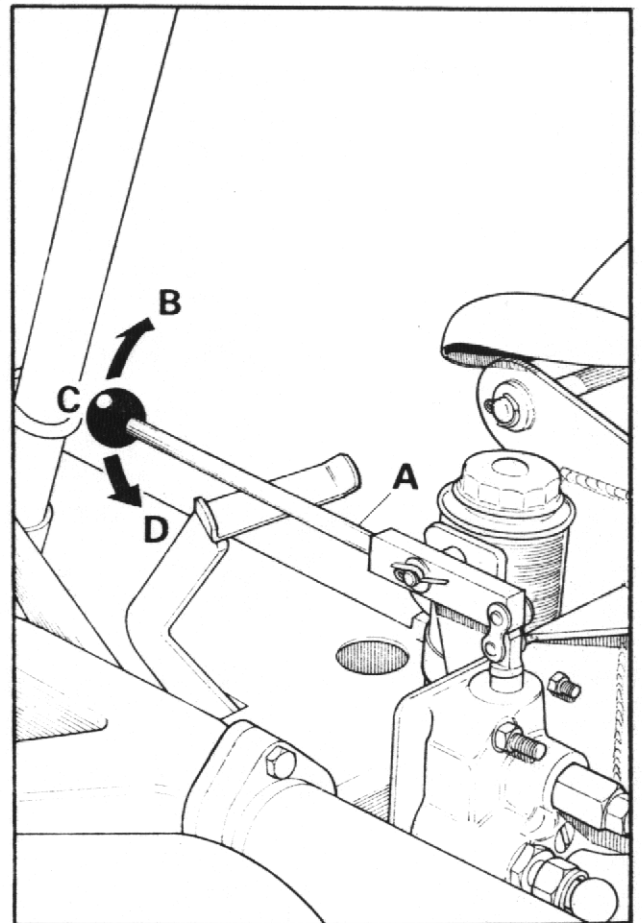

FIG 4

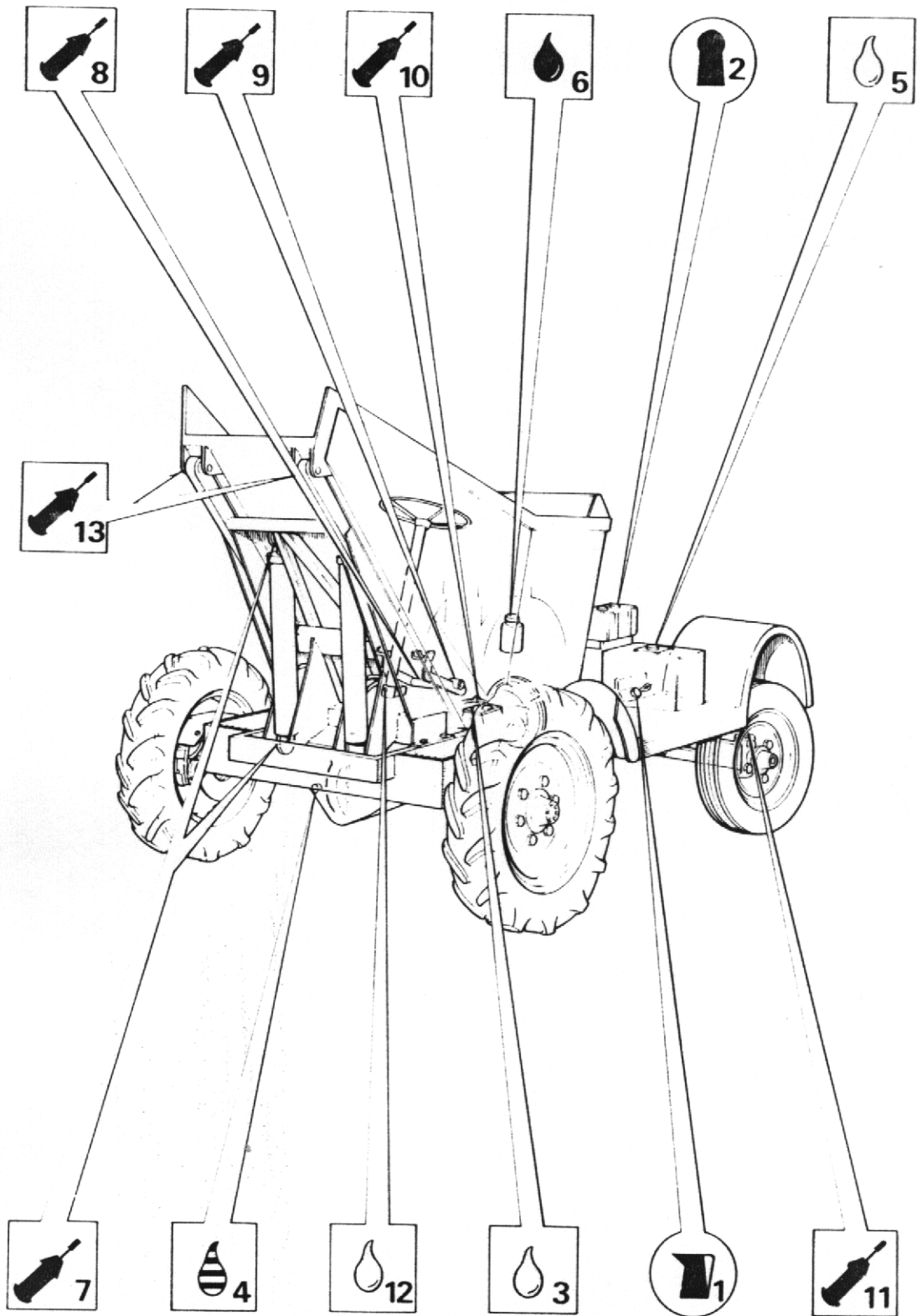









FIG 5

GENERAL MAINTENANCE

Lubrication Fig. 5

		No. of points
Daily		
1	Engine oil	1
2	Fuel Tank	1
Weekly		
3	Gearbox – oil	1
4	Drive Axle – oil	1
5	Hydraulic Tank – oil	1
6	Brake Master Cylinder Reservoir – brake fluid	1
7	Ram Bearings – grease	4
8	Footbrake Pedal – grease	1
9	Clutch Pedal – grease	1
10	Clutch Cross Shaft – grease	3
11	Steering Axle and Ball Ends – grease	8
12	Steering Box – oil	1
13	Skip Pivot – grease	1

Key

 Engine oil  Gearbox oil  Axle oil  Hydraulic fluid	 Brake fluid  Grease gun  Diesel fuel
---	---

- NOTES:-
1. Rear Axle Articulation Points consist of silentbloc bushes and do not require lubrication.
 2. For full details on the lubrication and maintenance of the engine, refer to the appropriate manufacturer's manual.

Recommended Lubricating Oils

see page 14.

Periodic Maintenance

1. DAILY check engine oil level and fill to full mark on dipstick, if necessary.
2. DAILY fill fuel tank, or as often as proves necessary, to within approximately 1" of top of tank. Never allow there to be a depth of less than 2" of fuel in the tank.
3. WEEKLY check oil level in gearbox and fill to full mark on dipstick, if necessary.
4. WEEKLY remove level/filler plug from drive axle. Oil level should be to bottom of hole. Top up if necessary.
5. WEEKLY check oil level in hydraulic tank. Always clean surrounding area before removing cap, to prevent possible entry of foreign matter. Fill tank if necessary, to within 1" of top.
6. WEEKLY check brake fluid in master cylinder reservoir and top up if necessary, to within 1/4" of top.
7. WEEKLY apply grease to all grease nipples.
8. WEEKLY check all wheel nuts and tighten, if necessary.
9. OCCASIONALLY check all nuts and bolts and tighten, if necessary.

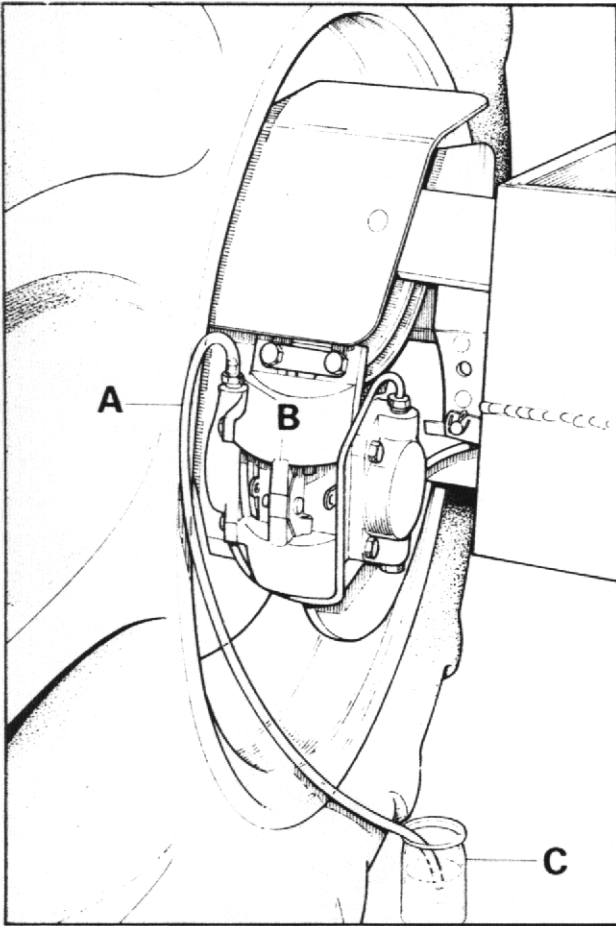

FIG 6

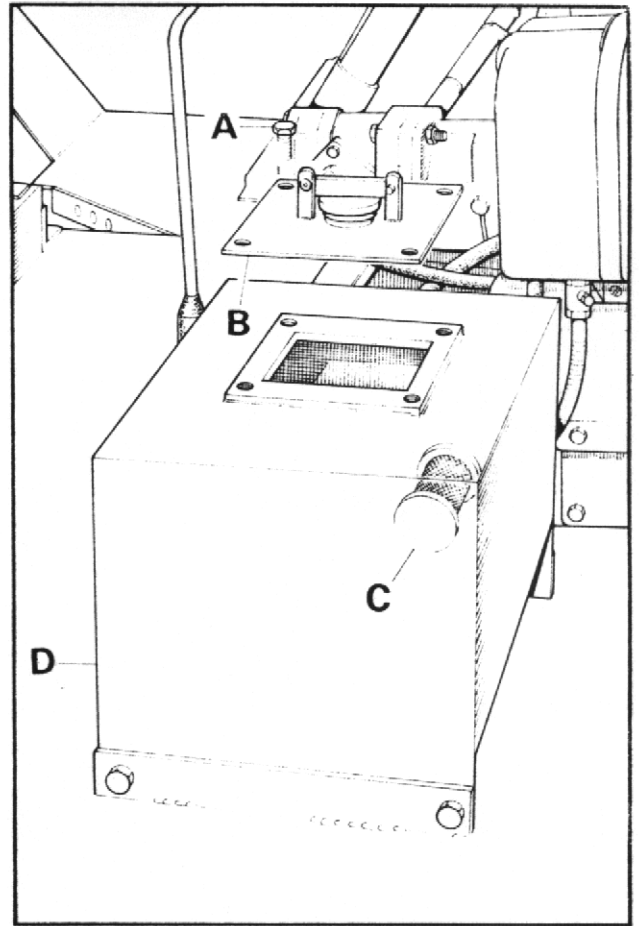

FIG 7

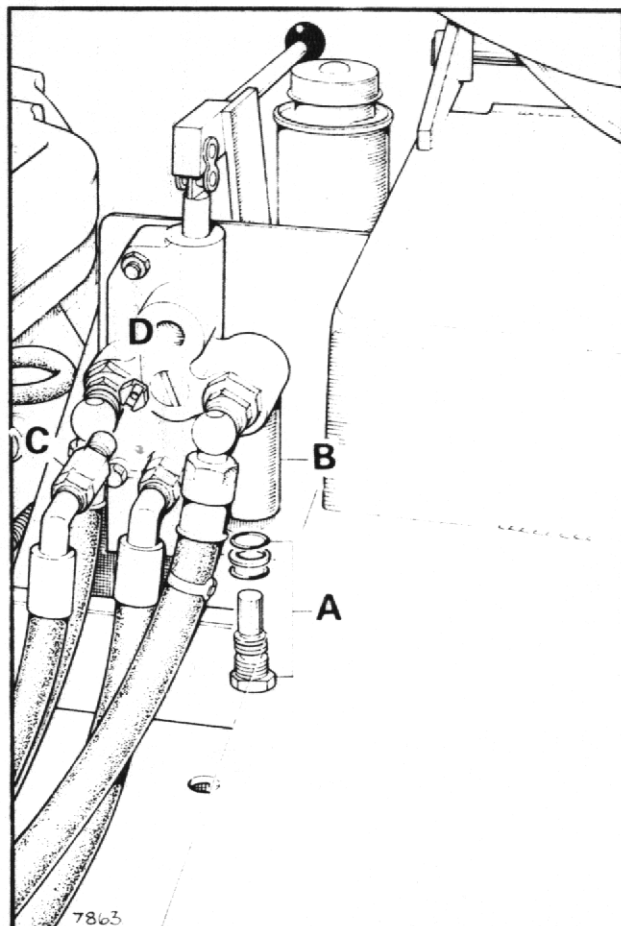

FIG 8

Brake System

The brake system is designed to require the minimum of maintenance, and, providing that the hydraulic fluid in the reservoirs is not allowed to fall below the recommended level no defect should normally occur. Fluid loss must be supplemented by topping up the reservoir with Girling Crimson Brake Fluid. No other fluid may be used. If air is present in the system, it will be indicated by sluggish response of the brake or by spongy action of the brake pedal. This may be due to air being introduced at a loose joint or by the reservoir fluid level being allowed to fall to a very low level. These defects must be remedied immediately and the complete system bled.

To bleed the system, proceed as follows. During the operation it is essential that the reservoir level is kept topped up to prevent further air from being drawn into the system. Only use new fluid for topping-up.

Fig. 6

1. Check that all connections are tight and all bleed screws are closed.
2. Fill reservoir with Girling Crimson Brake Fluid.
3. Attach bleeder tube (A) to bleed screw (B) of one wheel and immerse other end in a small quantity of brake fluid contained in a glass jar (C). Slacken bleed screw and operate brake pedal up and down through its full stroke until fluid pumped into jar contains no air bubbles. Hold down pedal and close bleed screw. Remove bleeder tube and release pedal.
4. Repeat on other wheel.
5. Lock both bleed screws and top up reservoir to correct level.
6. Apply normal working load on brake pedal for two or three minutes and examine entire system for leaks.

Main Hydraulic System

The main hydraulic system controls the dumping and return of the skip. If the skip fails to operate or does so extremely slowly, carry out the following procedures until the fault is rectified.

1. Check that hydraulic tank is full of oil.

Fig. 7

2.
 - a) Remove four setscrews (A) securing filler cap assembly (B) and remove assembly
 - b) Unscrew suction filter (C) from inside of tank (D) and wash in white spirits. Dry with moisture-free compressed air.
 - c) Replace suction filter and filler cap assembly.

NOTE: If suction filter cannot be thoroughly cleaned, fit a new one.

3. Check that hydraulic pressure is correct.
 - a) Fit a 2500 p.s.i. gauge into hydraulic line to base of rams.
 - b) Operate control lever to dump skip and check that pressure reading on gauge is 2000 p.s.i. when ram is fully-extended and relief valve is 'blowing'.

Fig. 8

4. Remove relief valve cartridge (A) (hexagon head) from end of control valve (B) opposite to control lever
5. Remove hose adaptor (C) from control valve, remove hexagonal orifice plate (D) and wash in white spirit. Dry using moisture-free compressed air. DO NOT poke wire, etc. into orifice. Re-fit plate and hose adaptor, with slot of orifice plate facing outwards.

If none of these procedures correct the fault, contact your local Winget agent

Periodically check the hose between the pump and the hydraulic tank to ensure that it is not deformed. Any deformation in the hose may result in a flow and damage the pump.

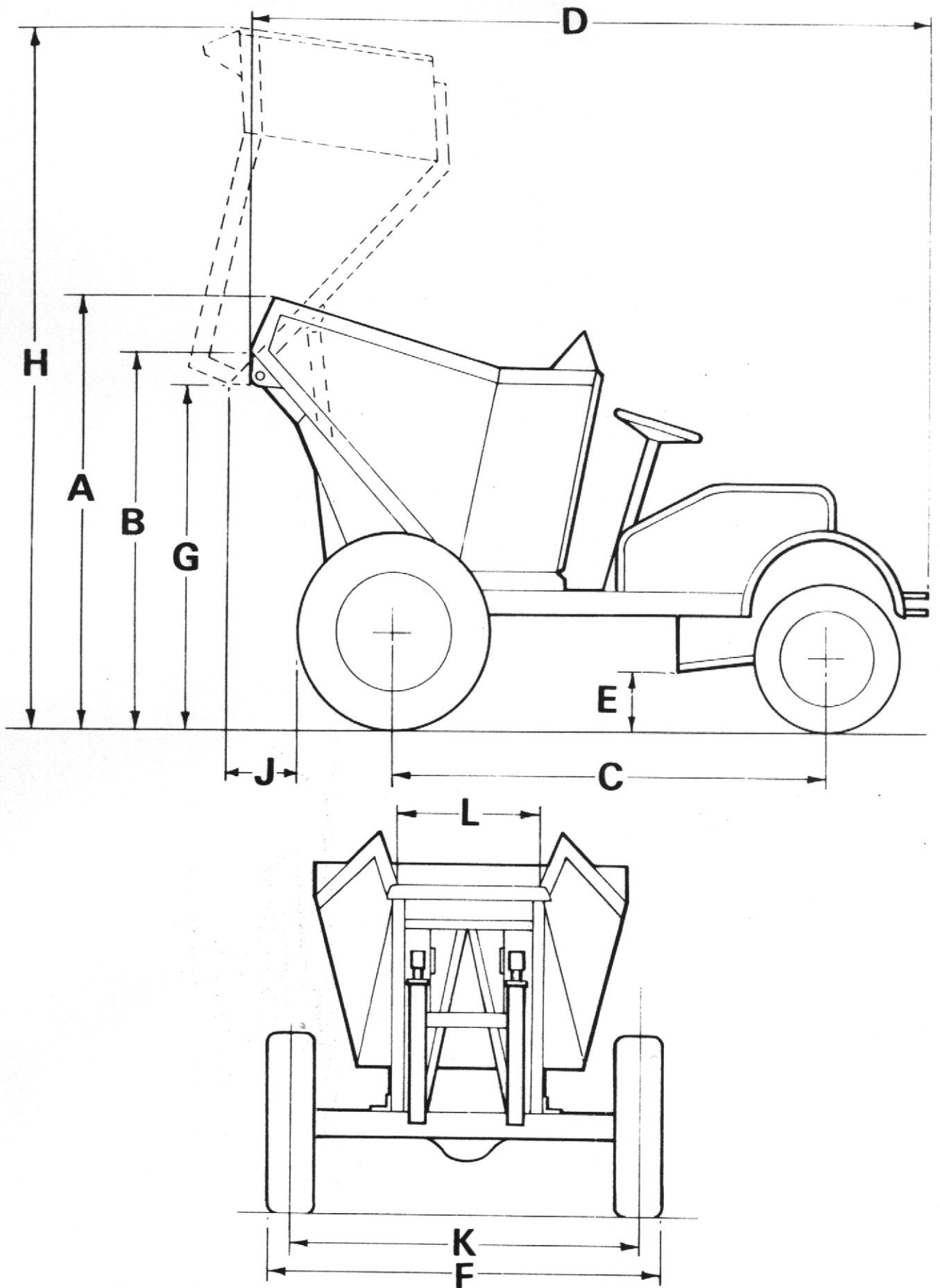

FIG 9

SPECIFICATION 5S HD DUMPER

Dimensions

A. Overall height	6' 5"	(1.95m)
B. Skip loading height	5' 10"	(1.78m)
C. Wheelbase	6' 7"	(2.01m)
D. Overall length	10' 7"	(3.22m)
E. Ground clearance	11"	(0.28m)
F. Overall width	6' 0"	(1.83m)
G. Skip ground clearance when tipped	5' 5"	(1.65m)
H. Overall height tipped	10' 8"	(3.25m)
J. Skip discharge distance/Reach from tyres	11½"	(0.29m)
K. Wheel track	5' 4"	(1.62m)
L. Skip discharge width	2' 2½"	(0.67m)

Turning circle	29' 9"	(9.06m)
Vehicle weight	1 ton 11 cwt. (1575kg)	
Rear axle articulation		

Skip Capacities

Water Level	34ft ³	(963 litres)
Maximum Payload	2 tons	(2032kg)

Tank Capacities

Diesel fuel tank		
Hydraulic oil tank	4 imp. galls.	(18.2 litres)

RECOMMENDED LUBRICATING OILS

COMPANY	ENGINE	DRIVE AXLE TRANSFER BOX & STEERING BOX	GEARBOX	WHEEL BEARINGS & OTHER GREASE POINTS	HYDRAULIC SYSTEM
(U.K.) ESSO (Overseas)	ESSOLUBE HDX 20W ESSOLUBE HDX 30 ESSOLUBE HDX 20W ESSOLUBE HDX 10W	GEAR OIL GP85W/140 GEAR OIL GP 85W/140 GEAR OIL GP 85W/140 GEAR OIL GP 80W	ESSOLUBE HDX 30 ESSOLUBE HDX 30	BEACON 2 BEACON 2	NUTO H32 NUTO H68 NUTO H32 NUTO H22
(U.K.) CASTROL	DEUSOL CRB 20 DEUSOL CRB 30 DEUSOL CRB 20 DEUSOL CRB 10	DEUSOL GEAR EP 90 DEUSOL GEAR EP 140 DEUSOL GEAR EP 90 DEUSOL GEAR EP 80	DEUSOL CRB 30 DEUSOL CRB 30	CASTROL SPEEROL APT 2 CASTROL SPEEROL APT 2	CASTROL HYSPIN AWS 32
(U.K.) SHELL (Overseas)	ROTELLA SX OIL 20/20W ROTELLA SX OIL 30 ROTELLA SX OIL 20/20W ROTELLA SX OIL 10W	SPIRAX 90 EP SPIRAX 140 EP SPIRAX 90 EP SPIRAX 80 EP	ROTELLA SX OIL 30 ROTELLA SX OIL 30	RETINAX A RETINAX A	TELLUS OIL 37
(U.K.) BP (Overseas)	VANELLUS M20W VANELLUS M30 VANELLUS M20W VANELLUS M10W	GEAR OIL SAE 90 EP GEAR OIL SAE 140 EP GEAR OIL SAE 90 EP GEAR OIL SAE 80 EP	VANELLUS M30 VANELLUS M30	ENERGREASE L2 ENERGREASE L2	ENERGOL HLP 65
(U.K.) MOBIL	DELVAC 1220 DELVAC 1230 DELVAC 1220 DELVAC 1210 DELVAC SPECIAL 10W-30	MOBILUBE HD 90 MOBILUBE GX 90 MOBILUBE HD 140 MOBILUBE GX 140 MOBILUBE HD 90 MOBILUBE GX 90 MOBILUBE HD 80 MOBILUBE GX 80	DELVAC 1230 DELVAC 1230	MOBILGREASE MP MOBILGREASE SUPER	DTE 24
(Overseas) ALL TEMPERATURES	CENTLUBE HD 20 CENTLUBE HD 30 CENTLUBE HD 20 CENTURY ROIL 10W	CENTURY EP 90 CENTURY EP 140 CENTURY EP 90 CENTURY EP 80	DELVAC 1230 CENTLUBE HD 30 CENTLUBE HD30	REGULUS A2 REGULUS A2	CENTURY PWLA HYD OIL CENTURY PWLA HYD OIL
(U.K.) WALKERS CENTURY (Overseas)	CENTLUBE HD 20 CENTLUBE HD 30 CENTLUBE HD 20 CENTURY ROIL 10W	CENTURY EP 90 CENTURY EP 140 CENTURY EP 90 CENTURY EP 80	CENTLUBE HD 30 CENTLUBE HD30	REGULUS A2 REGULUS A2	CENTURY PWLA HYD OIL CENTURY PWLA HYD OIL

IN THE UNLIKELY EVENT OF THE ABOVE OILS NOT BEING AVAILABLE
EQUIVALENT OILS SUPPLIED BY A REPUTABLE MANUFACTURER MAY BE USED

SPARE PARTS SECTION

LIST OF CONTENTS

TITLE	PAGE NO.
CHASSIS	20-21
SKIP & FRAME	22-23
CLUTCH ASSEMBLY	24
GEARBOX	25-28
DRIVE AXLE SALISBURY 10HA-001-35	29-30
PROPSHAFT & COUPLING	31
DRIVE WHEELS/FRONT 7.50 X 20	32
DRIVE WHEELS/FRONT 10.5 X 18	33
STEERING WHEELS/REAR	34
STEERING AXLE	35-36
STEERING GEAR (CAM & ROLLER)	37-38
PEDALS & CONTROLS	39-40
HANDBRAKE ASSEMBLY	41
BRAKE CALIPER	42
BRAKE PIPES & FITTINGS	43
MASTER CYLINDER	44
HYDRAULIC HOSES & FITTINGS	45-46
TIPPING CYLINDER	47
HYDRAULIC PUMP	48
HYDRAULIC CONTROL VALVE	49-50

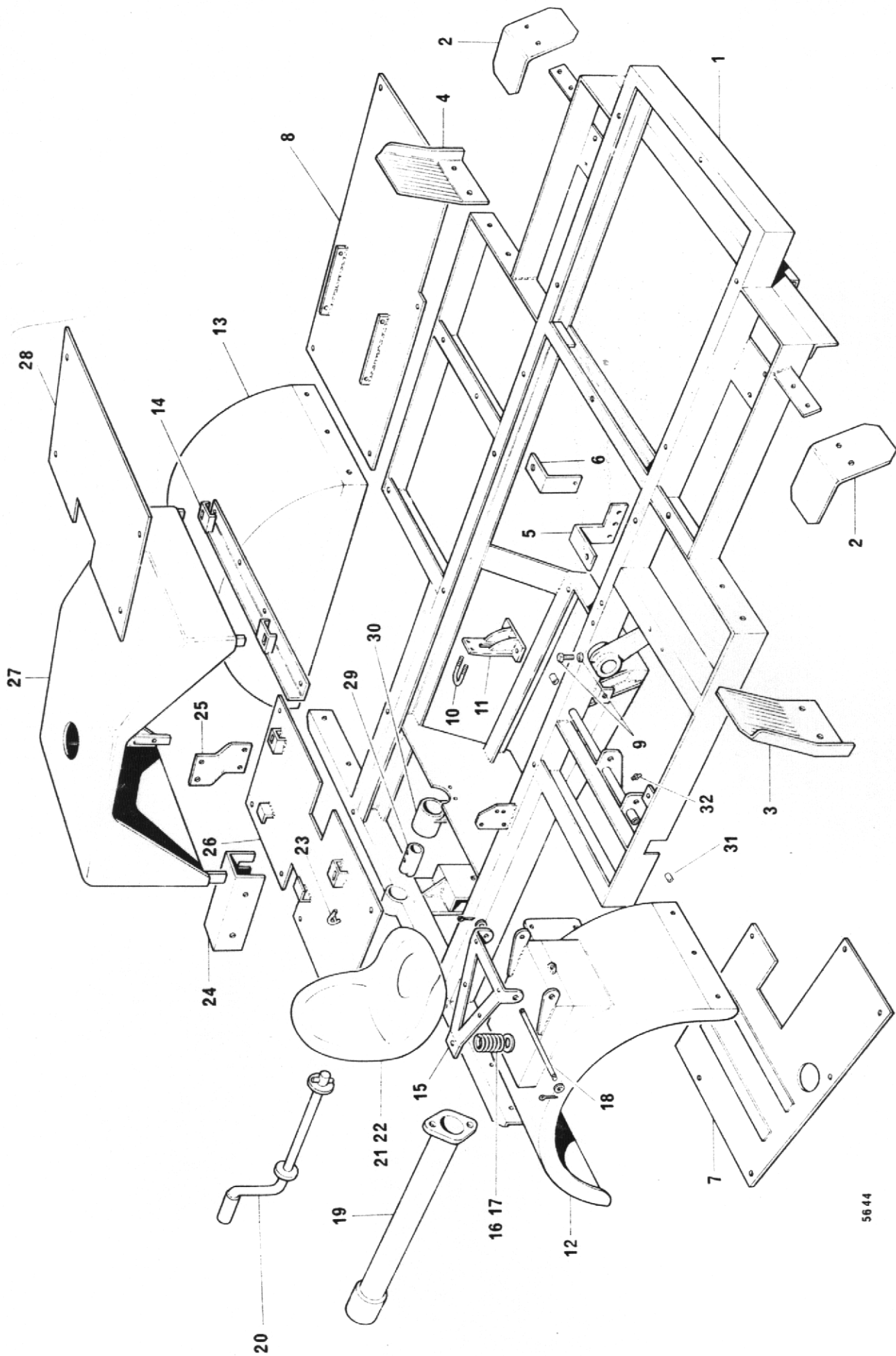

CHASSIS, WINGS, ENGINE COVER ETC.

<i>Item No.</i>	<i>Part No.</i>	<i>Description</i>	<i>No. Off</i>
1	5SHD 52	Chassis	1
2	5S - 109	Cowling, Disc Brake	2
3	L283 - RH	Mudflap R.H.	1
4	L283 - LH	Mudflap L.H.	1
5	T10	Support, Gearbox R.H.	1
6	T9	Support, Gearbox L.H.	1
7	T27	Footplate R.H.	1
8	5SHD 55	Footplate L.H.	1
9	C212	Lockbolt and Nut	2
10	C125	'U' Bolt and Nuts	1
11	C117	Support, Steering Column	1
12	5ST105	Mudwing R.H.	1
13	L252B	Mudwing L.H.	1
14	5ST90	Support, Engine Cover	1
15	5ST80	Frame, Seat	1
16	5ST99	Spring, Seat	1
17		Nut and Bolt 3/8" UNF x 3" Long	1
18	4-35-79	Rod, Seat	1
19	5S111	Pipe, Exhaust	1
20	F534	Handle, Starting	1
21	4-35-75	Seat	1
22	4-35-198	Upholstery (Not Illustrated)	1
23	L287-B	Spring and Clip, Starting Handle	1
24	F539	Support, Engine Fuel Tank	1
25	F540	Support, Engine Fuel Tank	1
26	5ST91	Footplate, Rear	1
27	5ST3	Cover, Engine	1
28	5ST-29	Footplate, Centre	1
29	L259 P	Dog, Starter	1
30	4SI00B/21A	Siroud, Starter Dog	1
31	WB0808	Bush	2
32	TST	Grease Nipple	1

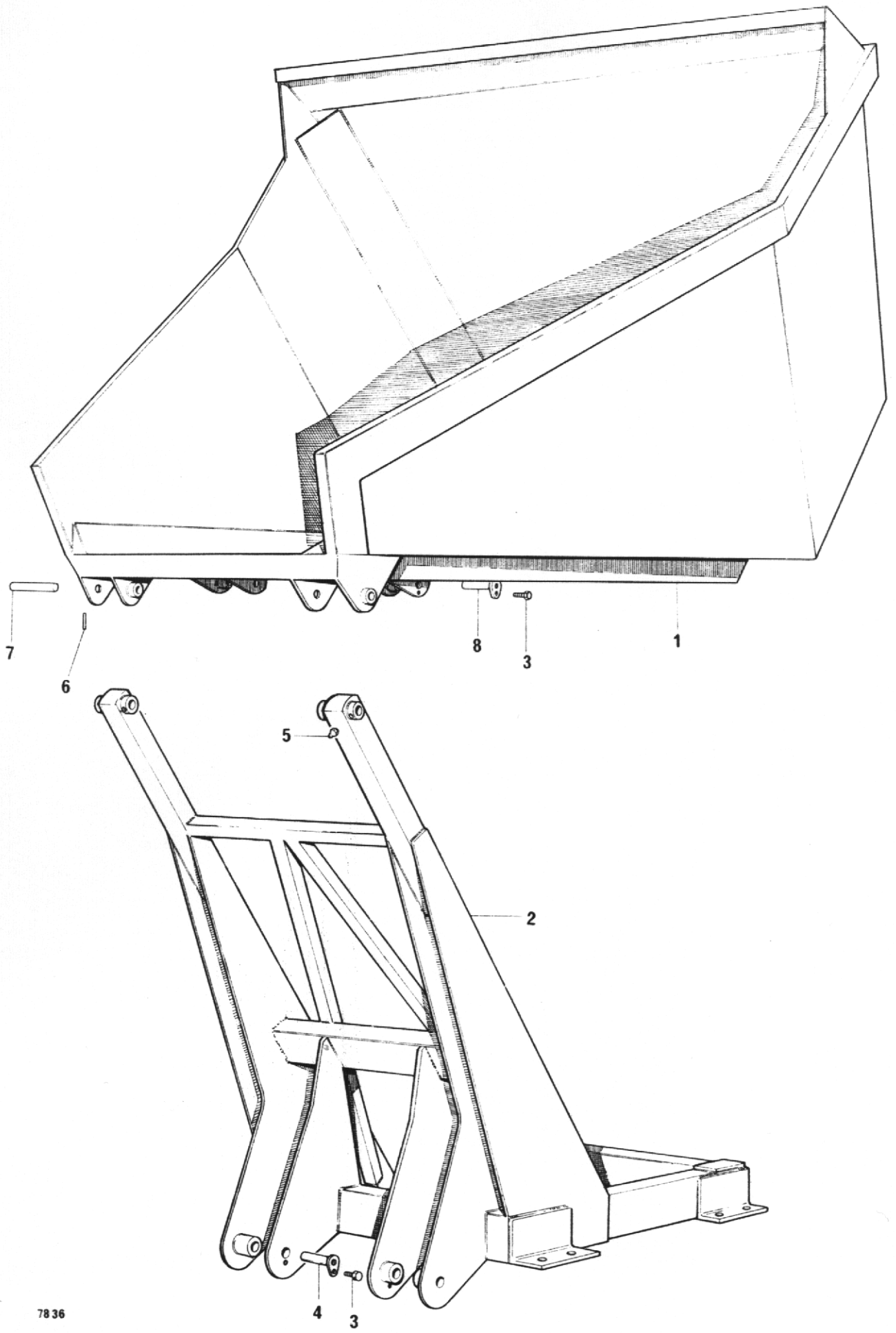

SKIP & FRAME

<i>Item No.</i>	<i>Part No.</i>	<i>Description</i>	<i>No. Off</i>
1	4-35-210	Skip	1
2	5SHD 51	Frame	1
3		Bolt 5/16" UNF x 3/4" Long	4
4	4-35-226	Lower Ram Pin	2
5	T-ST	Grease Nipple	2
6	4-35-29 A	Tension Pin 5/16" Dia. x 2.1/4" Long	2
7	ST105	Skip Pivot Pin	2
8	4-35-178	Ram Pin	2

FLYWHEEL AND CLUTCH ASSEMBLY

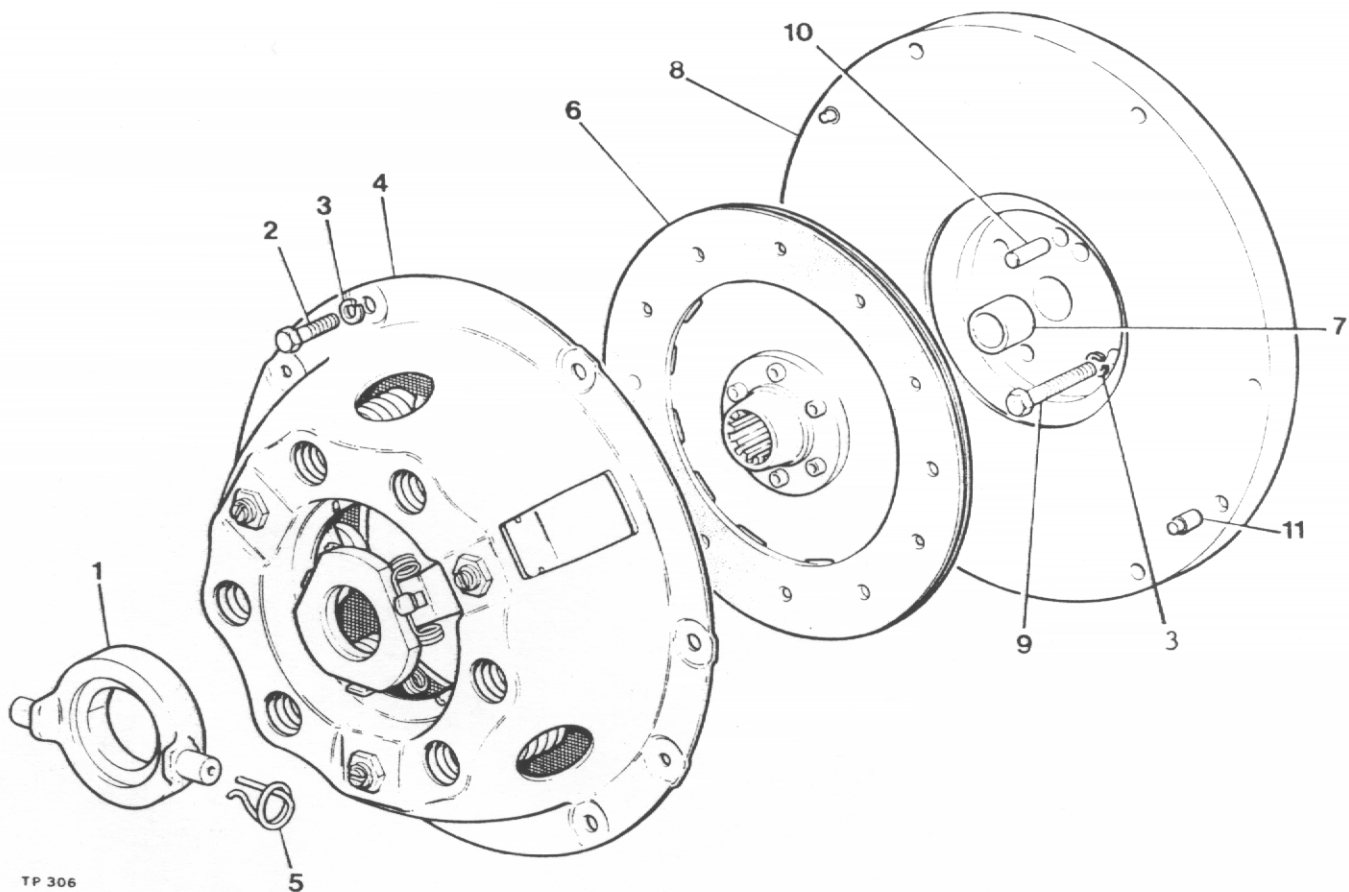

TP 306

Item No.	Part No.	Description	Qty.
1	10579A01	Clutch Release Bearing	1
2	28S02D	Screw Set	6
3	41S04	Washer Spring	10
4	10597A01	Cover Assembly	1
5	10579A101	Retainer Spring	2
6	10598A02	Drive Plate	1
7	10580A0101	Bush	1
8	10580A02	Flywheel Assembly (comprises of items 7, 8, & 11)	1
9	1S02C	Bolt, Petter PH Engine (drill for locking wire)	4
9A	6S02B	Bolt, Lister Engine (drill for locking wire)	4
10	C321	Dowel	1
11	10580A0102	Dowel	2
	10948A02	Clutch Kit (comprises of items 1, 4, 5 & 6)	1

It is recommended that instead of drilling the head of the bolts (item 9) for locking wire that one of each of tabwashers part no's 10531A02 and 10531A03 are used to prevent the bolts working loose.

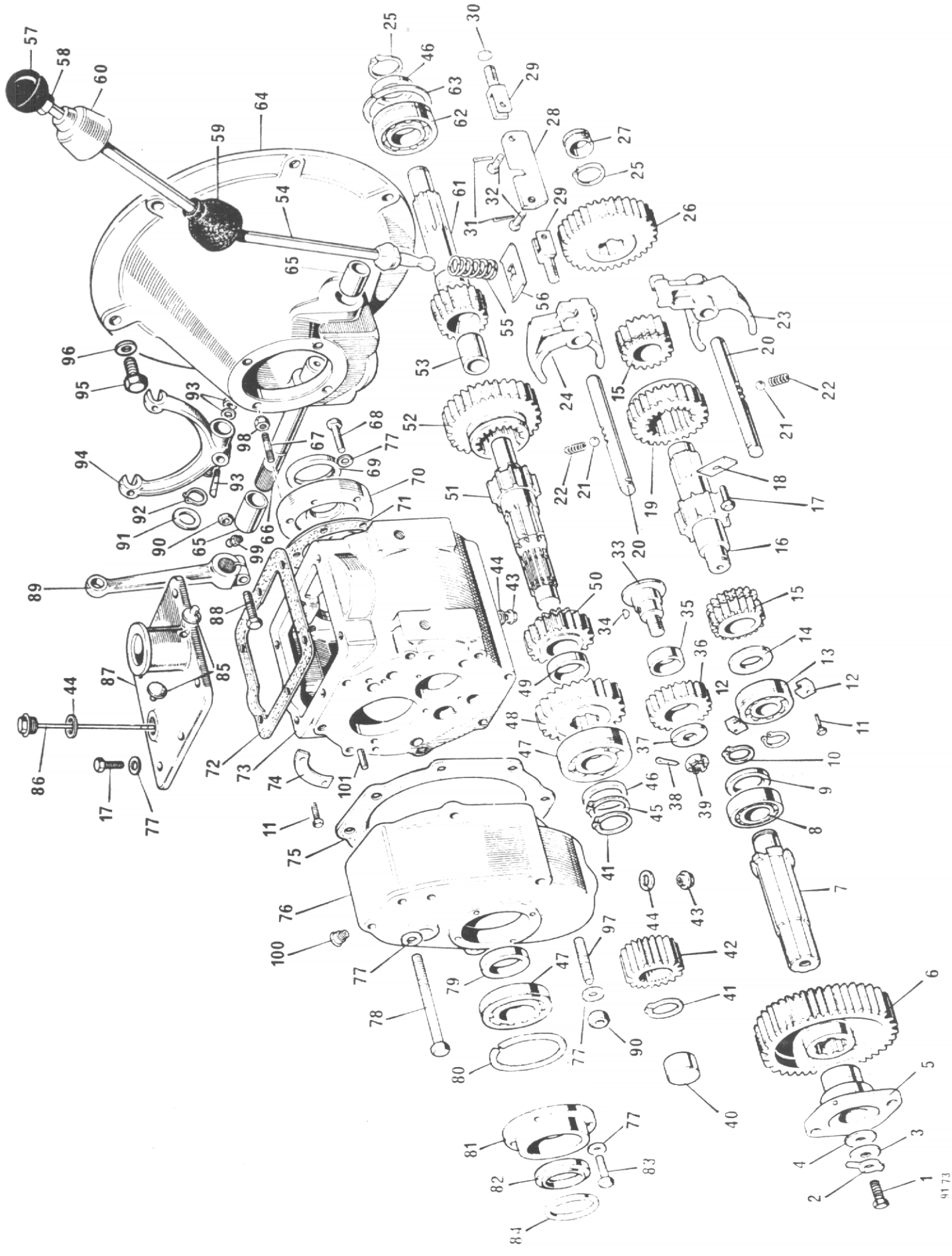

GEARBOX 40M/83D

<i>Item No.</i>	<i>Part No.</i>	<i>Description</i>	<i>No. Off</i>
1	US F55	Screw, Coupling	1
2	CM2050	Lockwasher	1
3	CM2123	Washer, Coupling	1
4	40M/340	Washer, Fibre	1
5	40M/383	Flange, Drive (Type 70) 9/16" Bolts	1
6	40M/314	Gear, Driven	1
7	40M/313	Shaft, Output	1
8	40M/327	Bearing	1
9	40M/325	Spacer, Bearing	1
10	40M/148	Circlip	1
11	USF11	Screw, Bearing Retaining	2
12	40M/299	Clip, Layshaft Bearing	3
13	40M/146	Bearing, Rear Layshaft	2
14	40M/130	Spacer, Bearing	1
15	40M/114	Gear, Reverse Speed	1
16	40M/118	Layshaft	2
17	USF21	Screw, Top Cover and Lock Strip	1
18	40M/136	Strip, Locking (Selector)	13
19	40M/116	Gear, Second Speed Sliding	1
20	40M/135	Shaft, Selector	1
21	CP1077	Ball, Detent CM2051 up to Serial No.4615	2
22	CM2103	Spring, Detent	2
23	40M/501	Fork, Selector (First and Reverse) 40M/228 up to Serial No.4615	2
24	40M/502	Fork, Selector (Second and Third) 40M/229 up to Serial No.4615	1
25	CM2053	Circlip, Primary Shaft	1
26	40M/360	Gear, First Reduction	3
27	40M/162	Bush, Layshaft	1
28	40M/505	Plate, Interlock	1
29	40M/231	Stud, Interlock	1
30	CM2113	Disc Sealing	2
31	40M/244	Split Pin, Interlock	3
32	40M/232	Clevis Pin, Interlock	2
33	40M/119	Shaft, Reverse Pinion	2
34	40M/222	Key, Reverse Pinion Shaft	1
35	40M/161	Bush, Reverse Pinion	1
36	40M/111	Pinion, Reverse	1
37	40M/155	Washer, Reverse Pinion Shaft	1
38	CP1004	Pin, Split	1
39	UN507	Nut, Reverse Spindle	1
40	40M/346	Roller, Needle	1
41	40M/347	Circlip	1
42	40M/349	Gear, Drive	2
43	CP1002	Plug, Drain	1
44	CP1068	Washer, Drain Plugs and Dipstick	2
45	40M/348	Circlip	3
46	40M/174	Spacer, Bearing	1
47	CM2052	Bearing, Rear Mainshaft	2
48	40M/110	Gear, Output	2
49	40M/128	Spacer, Output Shaft	1
50	40M/113	Gear, Second Speed	1
51	40M/516	Shaft, Main 40M/345 up to Serial No.5415	1
52	40M/115	Gear, First Speed	1
53	40M/513	Bush, Primary Shaft	1
54	40M/372	Lever, Gear	1
55	40M/367	Spring, Gear Lever	1
56	40M/245	Plate, Gear Lever Retaining	1
57	40M/133	Knob, Gear Lever	1
58	UN512	Nut, Gear Lever	1
59	40M/129	Cover, Gear Lever	1
60	40M/377	Cover, Protective	1

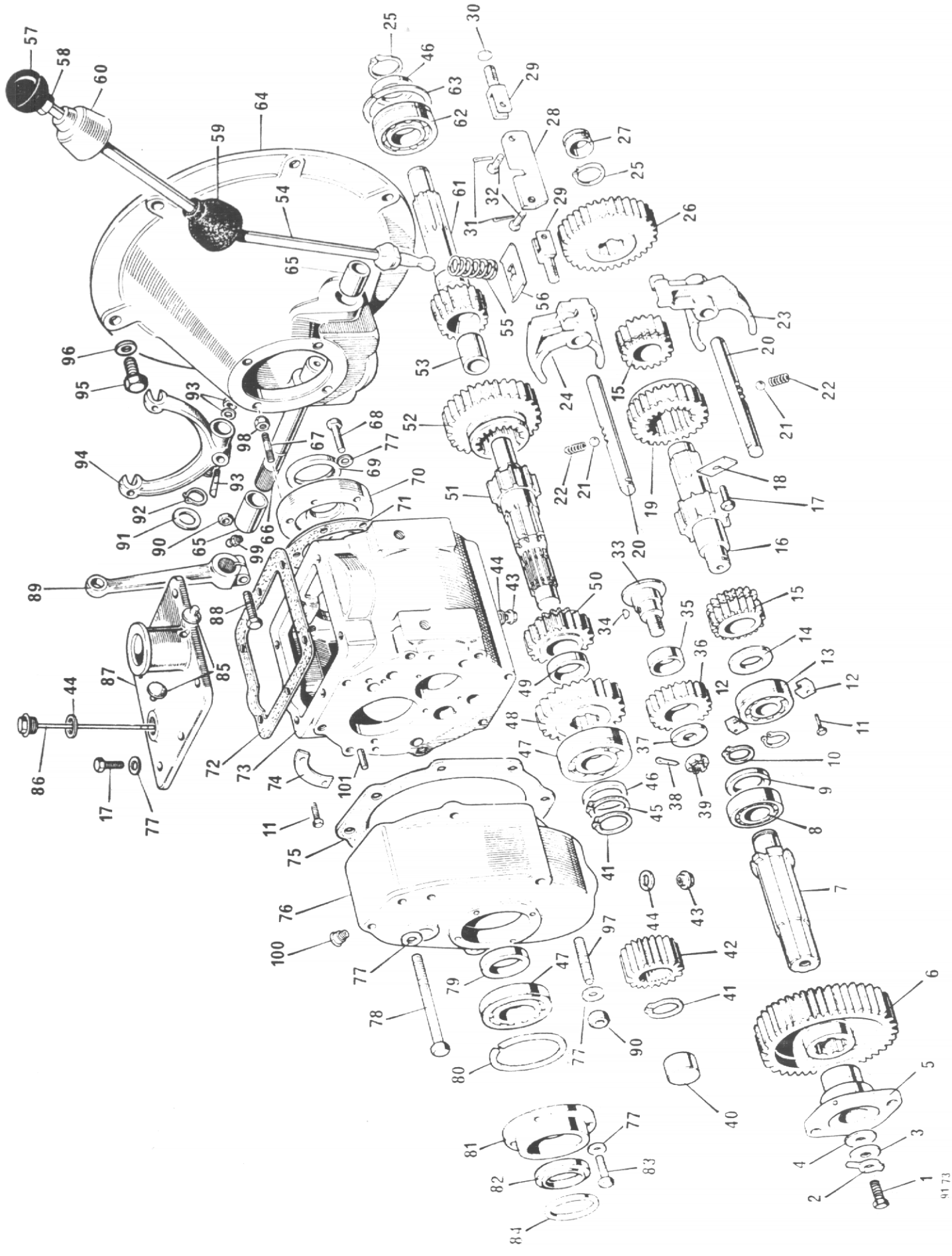

GEARBOX 40M/83D Cont'd.

<i>Item No.</i>	<i>Part No.</i>	<i>Description</i>	<i>No. Off</i>
61	40M/117	Shaft, Primary	1
62	40M/143	Bearing, Input	1
63	40M/252	Ring, Snap	1
64	40M/392	Housing, Clutch	1
65	CM2179	Bush, Clutch Cross Shaft	2
66	40M/394	Cross Shaft, Clutch	1
67	40M/177	Stud	6
68	UBF71	Bolt, Front Cover	4
69	40M/150	Oil Seal , Input	1
70	40M/126	Cover, Front	1
71	40M/172	Joint, Front Cover	1
72	40M/169	Joint, Top Cover	1
73	40M/101/H	Casing, Gearbox	1
74	40M/141A	Retainer, Large Bearing	1
75	40M/626	Joint, Reduction Housing	1
76	40M/312	Housing, Reduction	1
77	W104	Washer, Front Cover, Top Cover Lock Strip and Reduction Housing	25
78	UBF191	Bolt, Reduction	4
79	40M/320	Spacer, Output Shaft	1
80	CM2060	Retainer Bearing	1
81	40M/622	Housing, Rear Oil Seal	1
82	40M/167	Oil Seal, Rear	1
83	USF31	Screw Reduction Housing	8
84	CM2201	Excluder, Dust	2
85	40M/254	Pin, Gear Lever	2
86	40M/153	Dipstick	1
87	40M/220	Cover, Gearbox	1
88	UBF91	Bolt, Clutch Lever	1
89	CM2090	Lever Clutch Release	1
90	UN501	Nut, Clutch and Reduction Housing	3
91	40M/398	Washer, Cross Shaft	1
92	CP1006	Circlip, Cross Shaft	1
93	CM2084/SA	Cotter, Nut and Washer	1
94	CM2083	Fork, Clutch Release	1
95		Bolt, Clutch Assembly 3/8 BSF x 1" long (Petter P.H.2) 3/8 UNC x 1" long (Lister S.R.2)	6 6
96		Spring Washer 3/8" dia.	6
97	40M/329	Stud	2
98	UNL106	Nut, Clutch Housing	6
99	CP1069	Nipple, Grease (Straight)	1
100	CM2106	Breather	1
101	40M/359	Dowel	1
102	5ST98	Gear Lever Extension	1

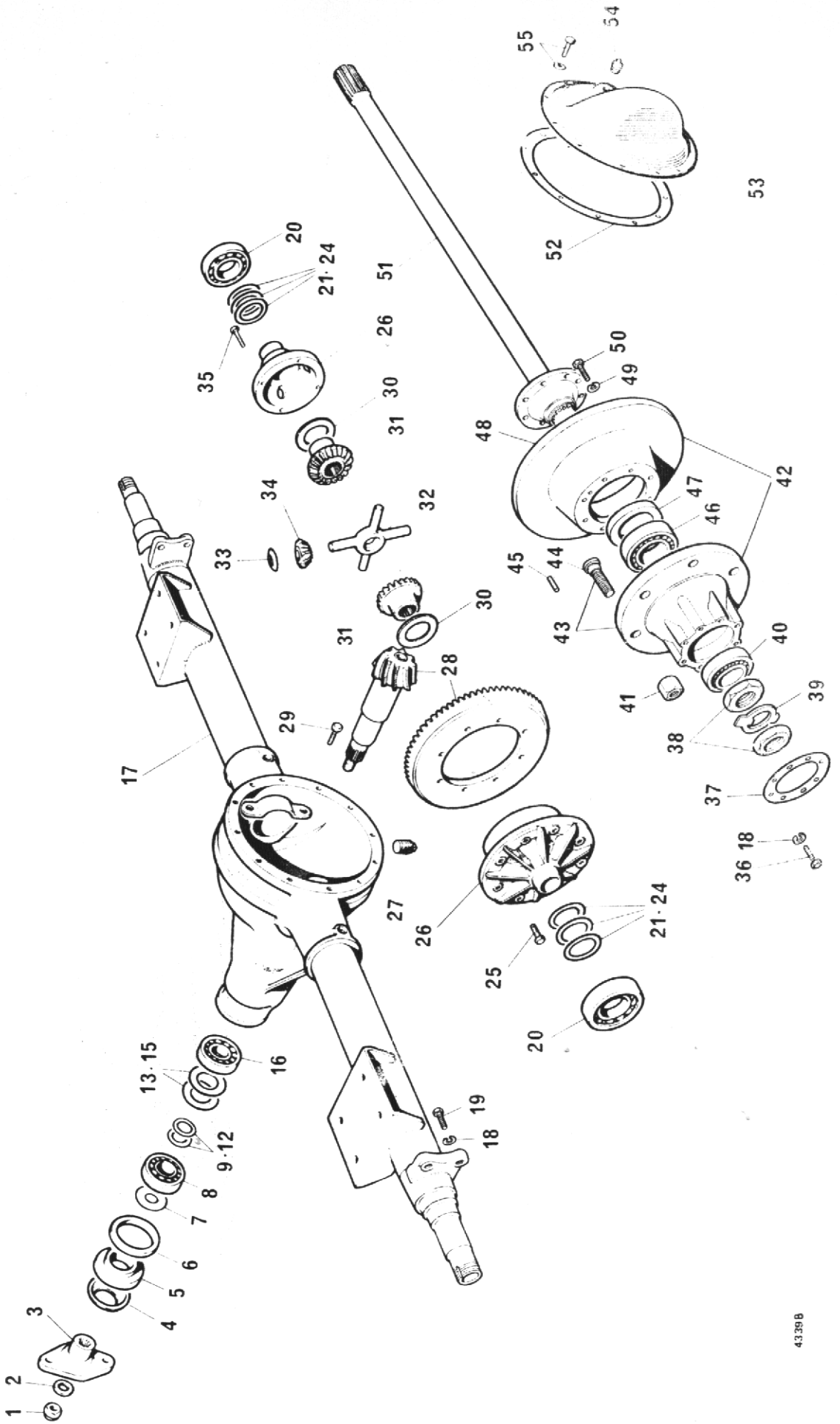

DRIVE AXLE 10HA-001-35

<i>Item No.</i>	<i>Part No.</i>	<i>Description</i>	<i>No. Qty</i>
1	14LN NF10A	Pinion Nut	1
2	14W-24	Pinion Nut Washer	1
3	10HA-083-7	Companion Flange (Type 70-4 5/16" Ctrs).	1
4	10HA-021-2	Companion Flange Dust Shield	1
5	8HA-019-3	Pinion Oil Seal	1
6	2HA-020	Pinion Oil Seal Gasket	1
7	10HA-036	Pinion Oil Slinger	1
8	10HA-022	Pinion Bearing Outer	1
9	5HA-039	Pinion Adjusting Shim Outer (.003 in.)	2 A/R
10	5HA-040	Pinion Adjusting Shim Outer (.005 in.)	2 A/R
11	5HA-041	Pinion Adjusting Shim Outer (.010 in.)	2 A/R
12	5HA-042	Pinion Adjusting Shim Outer (.030 in.)	2 A/R
13	10HA-043	Pinion Adjusting Shim Inner (.003 in.)	2 A/R
14	10HA-044	Pinion Adjusting Shim Inner (.005 in.)	2 A/R
15	10HA-045	Pinion Adjusting Shim Inner (.010 in.)	2 A/R
16	10HA-023	Pinion Bearing Inner	1
17	10HA-101-1	Service Carrier and Tube Assembly	1
18	7LW-13	Axle Shaft Flange Lock Washer	20
19	7BNF-22B	Brake Caliper Mounting Bolt	4
20	8HA-0242	Differential Bearing	2
21	8HA-046	Differential Bearing Shim (.003 in.)	2 A/R
22	8HA-047	Differential Bearing Shim (.005 in.)	2 A/R
23	8HA-048	Differential Bearing Shim (.010 in.)	2 A/R
24	8HA-049	Differential Bearing Shim (.030 in.)	2 A/R
25	8HA-075-1	Drive Gear Screw	12
26	21084X	Differential Case	1
27	HA-059	Drain Plug	1
28	21092X	Drive Gear and Pinion Assembly	1
29	8B NC 36	Differential Bearing Cap Screw	4
30	8HA 038	Differential Case Side Gear Thrustwasher	2
31	30788	Differential Side Gear	2
32	8HA-012-1	Differential Pinion Mate Shaft	1
33	30842	Pinion Mate Thrust Washer	4
34	8HA-008-1	Pinion Mate	4
35	30836	Differential Case Screw	8
36	7B-NC 20A	Axle Shaft Flange Driving Bolt	16
37	10HA-031	Axle Shaft Flange Gasket	2
38	32N-NF-4	Wheel Bearing Locknut	4
39	8HA-091-2	Wheel Bearing Locking Washer	2
40	8HA-025-6	Wheel Bearing Outer	2
41	T-23	Wheel Nut	12
42	10HA-028-7	Hub and Disc Assembly	2
43	10HA-028-9	Wheel Hub with Studs	2
44	10HA-005	Wheel Stud	12
45	6D-16	Brake Disc Dowel	4
46	8HA-025-5	Wheel Bearing Inner	2
47	5HA-032-6	Hub Oil Seal	2
48	10HA-136	Brake Disc	2
49	6WL-105	Brake Disc Retaining Washer	10
50	6BNF-21	Brake Disc Retaining Screw	10
51	10HA-005-5	Axle Shaft	2
52	31978	Gear Carrier Cover Gasket	1
53	30809	Gear Carrier Cover	1
54	HA-059	Filler Plug	2
55	6B-NC10	Cover Screw and Washer	10

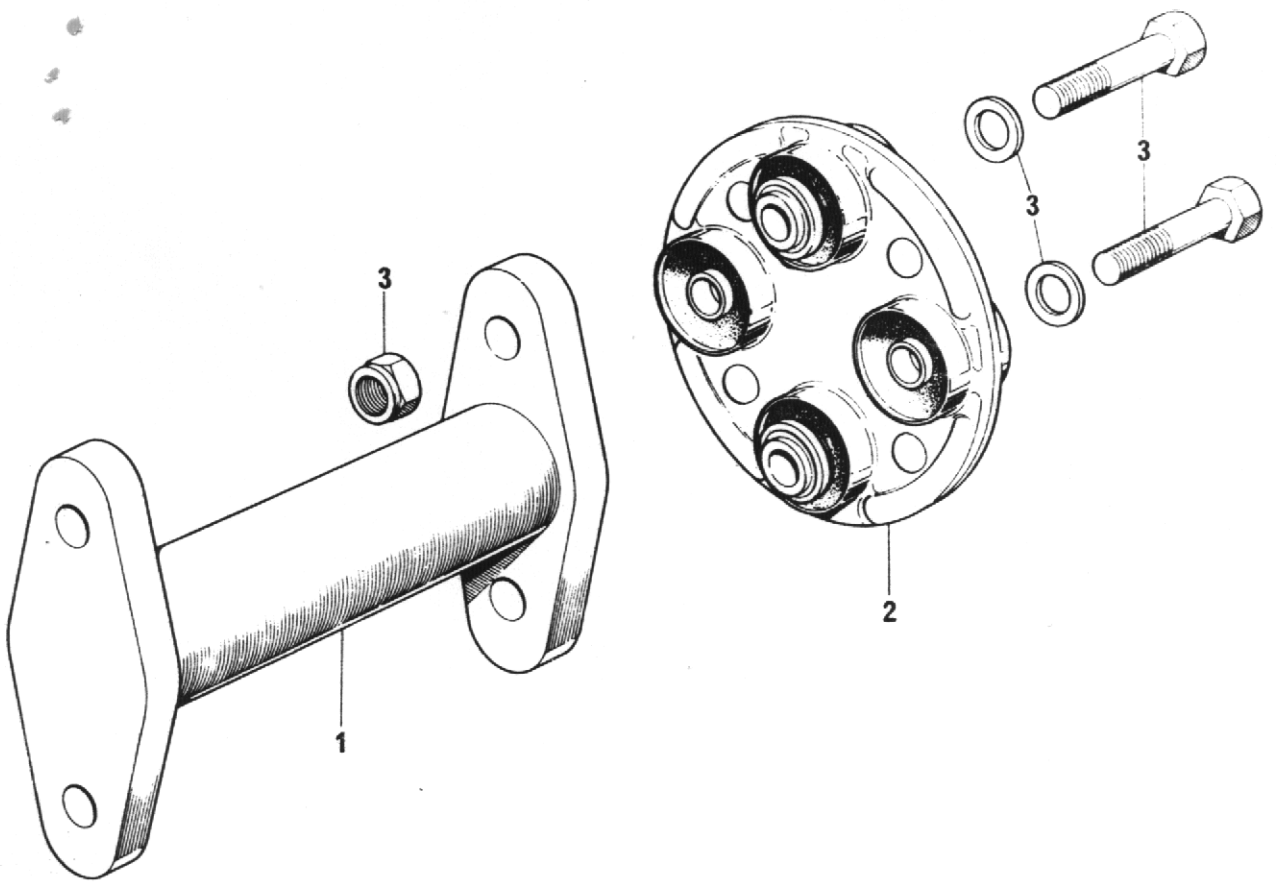

PROPELLOR SHAFT, COUPLING ETC.

<i>Item No.</i>	<i>Part No.</i>	<i>Description</i>	<i>No. Off</i>
		Propellor Shaft Assembly Complete comprising:-	1
1	5SHD 53	Propellor Shaft (9/16" Bolts - 4.5/16" CTRS)	1
2	10323A01	Coupling (Type 70) 4.5/16" CTRS	2
3	10203A	Bolt and Washer 9/16"	8

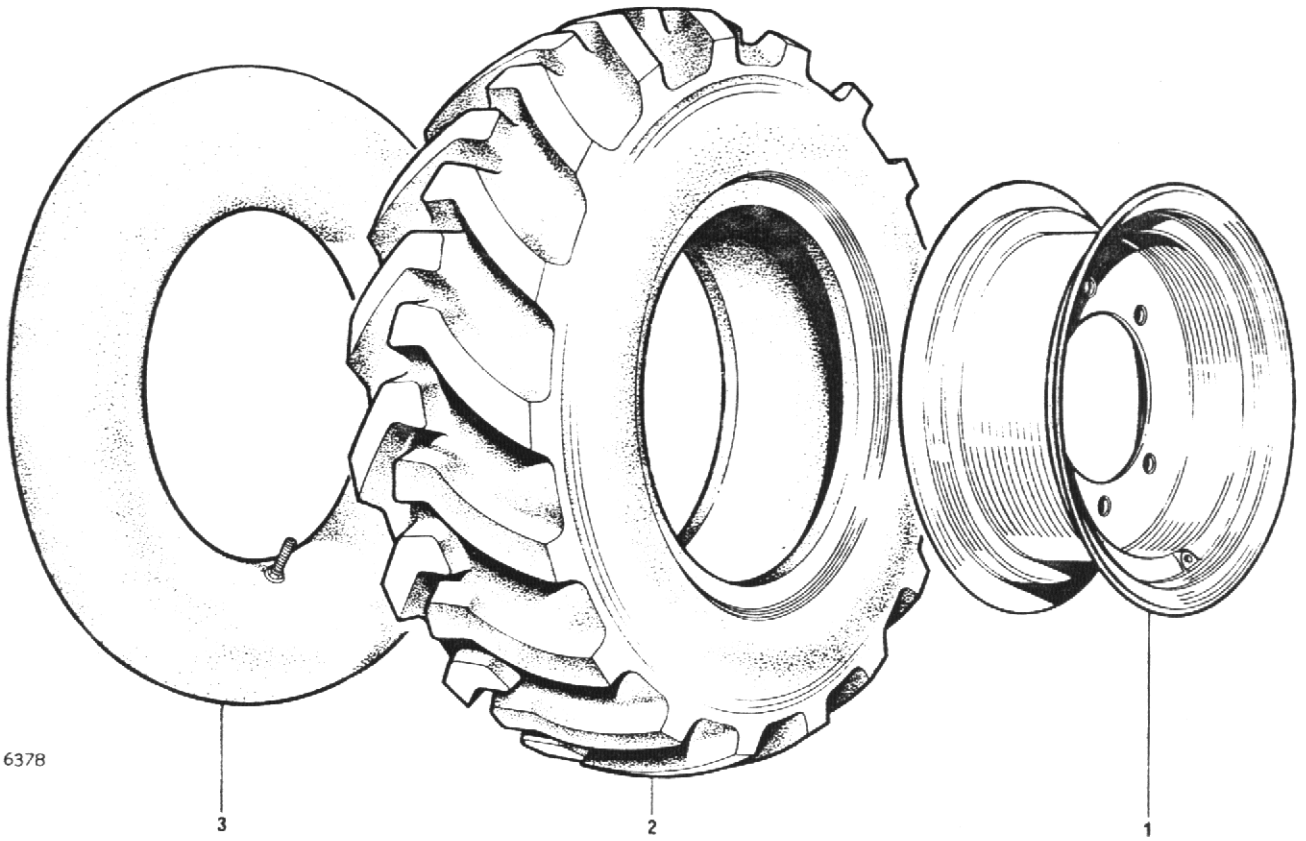

DRIVE WHEELS AND TYRES

Item No.	Part No.	Description	Qty.
	N.P.N.	R/H Wheel Assembly	1
	N.P.N.	L/H Wheel Assembly	1
1	30192A01	Wheel rim 5.50 x 16	2
2	20S07	Tyre 7.50 x 20-8 ply	2
3	23S14	Tube 7.50 x 20	2

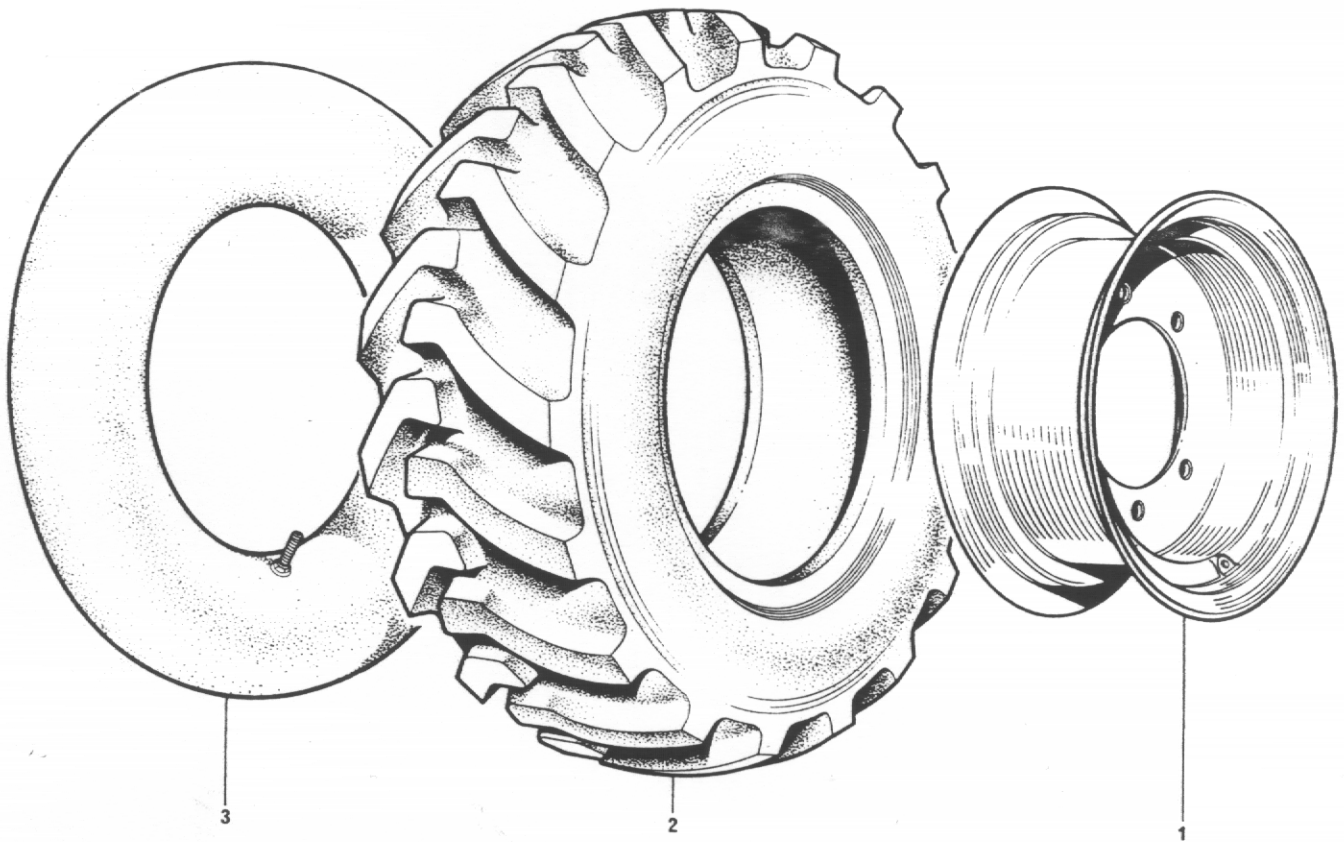

DRIVE WHEELS AND TYRES

Item No.	Part No.	Description	Qty.
1	24S16	R/H Wheel Assembly	1
1	24S15	L/H Wheel Assembly	1
2	30193A01	Wheel rim 9 x 18	2
2	20S01	Tyre 10.5 x 18-6 ply	2
3	23S04	Tube 10.5 x 18	2

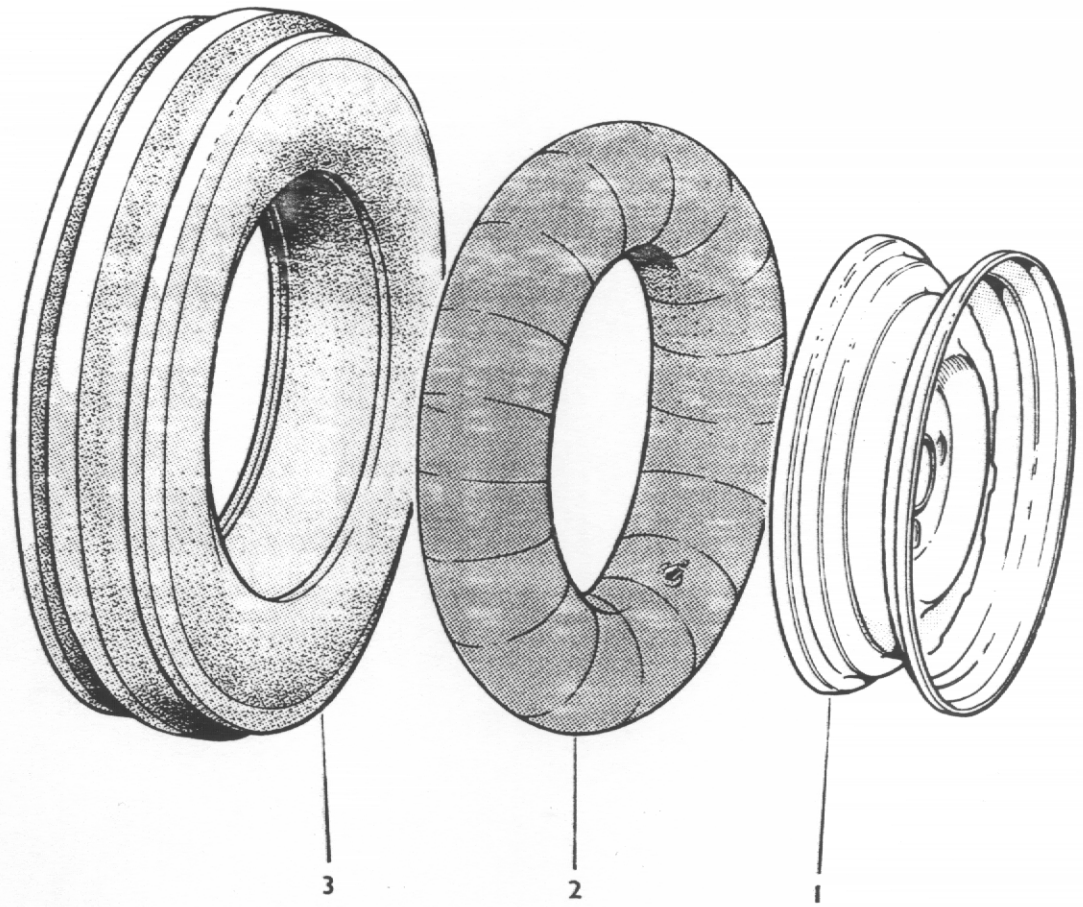

STEERING WHEELS AND TYRES

Item No.	Part No.	Description	Qty.
1	24S31	Steering wheel complete	2
2	30033A01	Wheel rim 4.00 x 16	2
3	23S02	Tube 6.00 x 16	2
	21S03	Tyre 6.00 x 16-4 ply	2

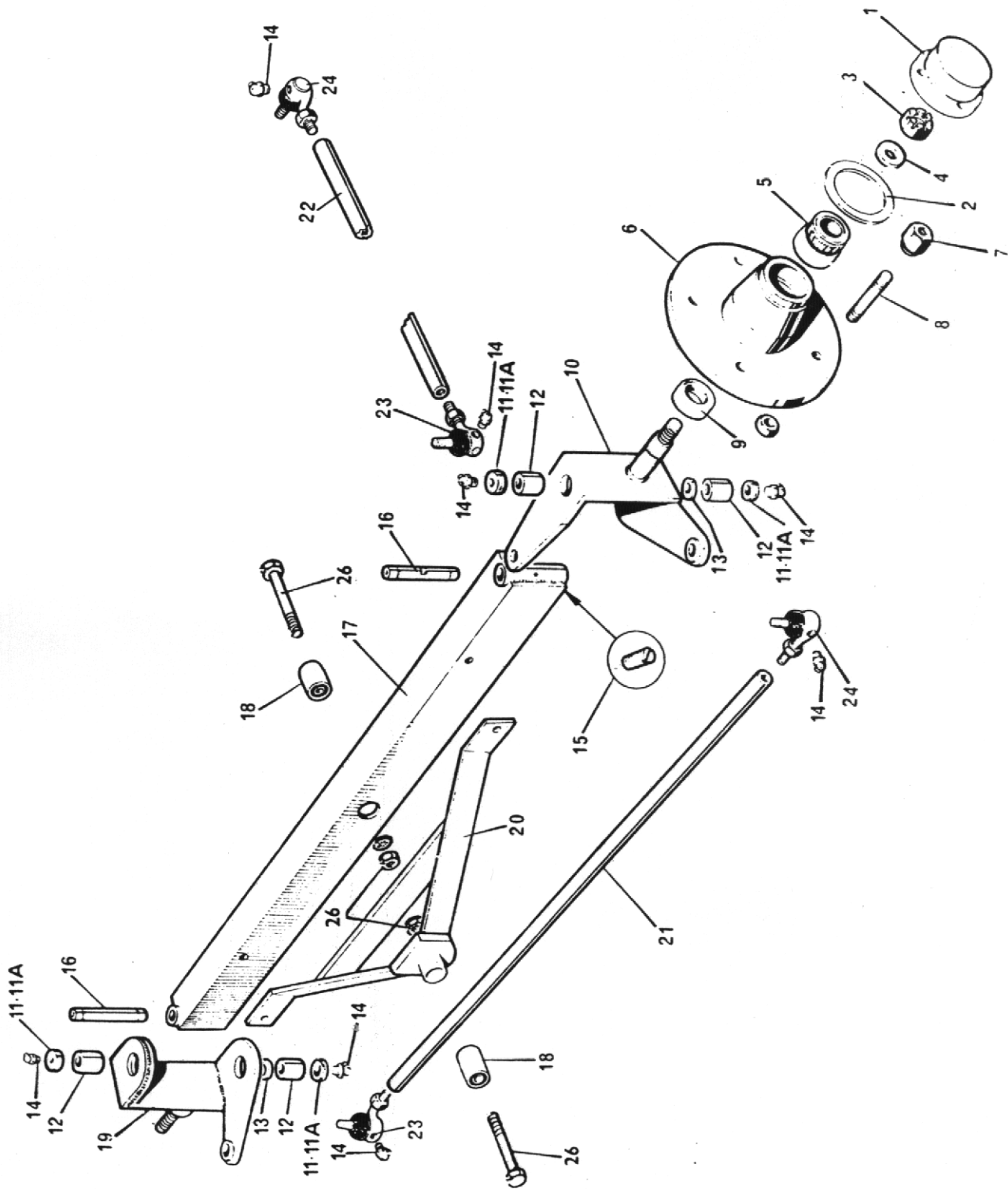

STEERING AXLE

<i>Item No.</i>	<i>Part No.</i>	<i>Description</i>	<i>No. Off</i>
1	R344	Hub Cap	2
2	R345	Gasket, Hub Cap	2
3	R305-A	Slotted Nut	2
4	4S149	Washer	2
5	K18690-K18620	Bearing, Hub	2
6	0190	Hub Assembly, including Items 1, 2, 5, 7, 8 & 9	4
7	R340	Wheel Nut	2
8	0190-S	Wheel Stud	10
9	R343	Oil Seal, Hub Bearing	10
10	F505-OS	Stub Axle Assembly O/S	2
11	C180-A	Washer, King Pin (Felt)	1
11A	C180-B	Washer, King Pin (Steel)	4
12	C190	Bush, King Pin	4
13	C175	Thrust Washer	4
14	T90	Grease Nipple	2
15	C111-A	Screw, King Pin Retaining	8
16	R320	King Pin	2
17	T17	Steering Axle Beam	2
18	E2245	Bush, Steering Axle and Stabiliser	1
19	F505-NS	Stub Axle Assembly N/S	2
20	L262	Steering Axle Stabiliser	1
21	5ST 31	Track Rod	1
22	T32	Drag Link	1
23	C159/LH	Steering Ball Joint with Nut	1
24	C159/RH	Steering Ball Joint with Nut	2
26		Bolt, 7/8" UNF x 4" Long & Nut	2

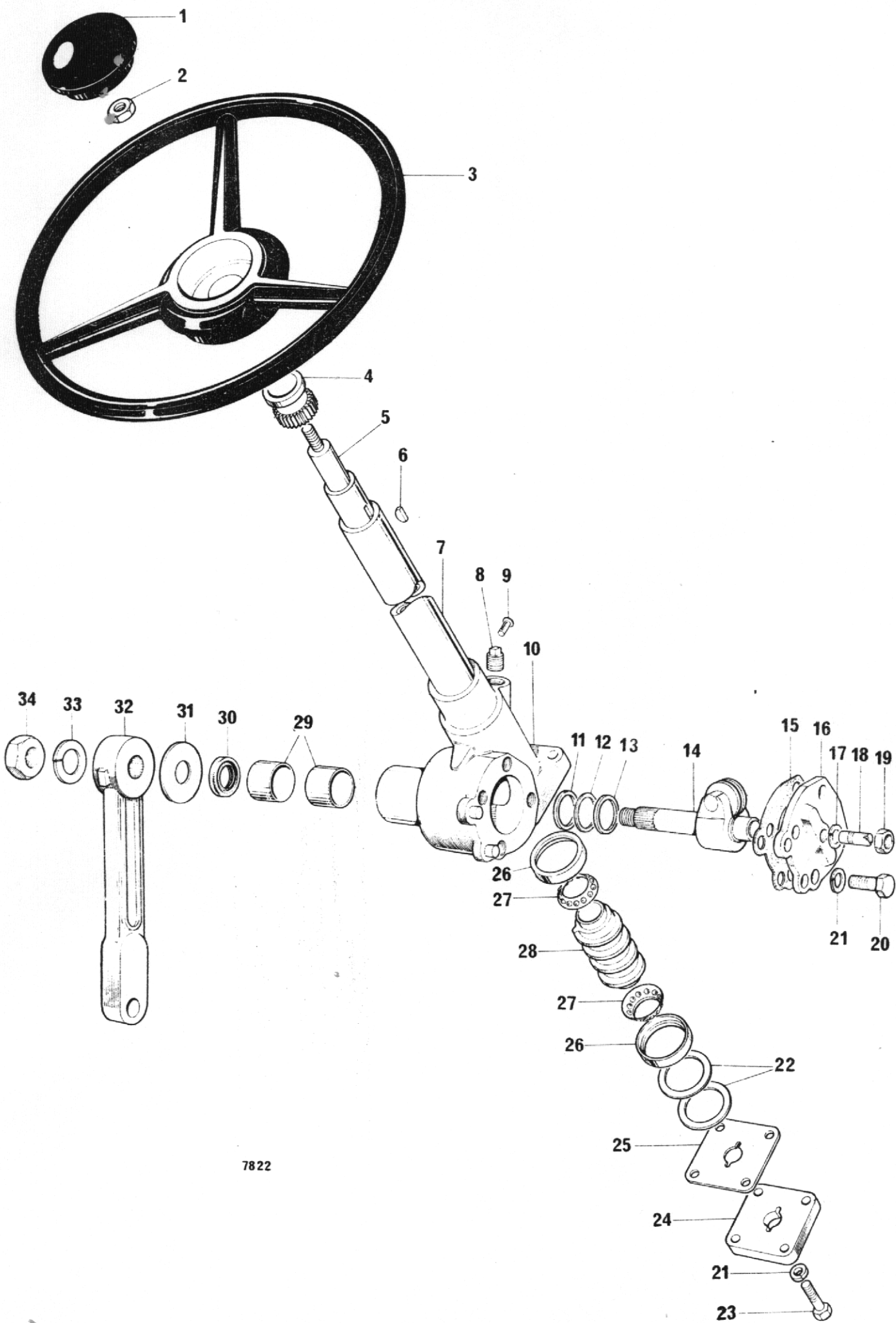

7822

STEERING GEAR

<i>Item No.</i>	<i>Part No.</i>	<i>Description</i>	<i>No. Off</i>
	562	Steering Column Assembly Only, Complete less items 1, 2, 3, & 32	1
1	153/A	Steering Wheel Cap	1
2	C 197	Nut	1
3	153	Steering Wheel	1
4	PA 3904	Bush, Column Top	1
5	M 24 733	Inner Shaft	1
6	No. 9	Woodruff Key	1
7	P 3911	Outer Tube	1
8	S 9033	Oil Plug	1
9	S 9166	Pin	1
10	P 3689	Steering Box	1
11	P 4151	Thrust Washer	1
12	P 3308	Shim	A/R
13	P 4151	Thrust Washer	1
14	PA 4044	Rocker Shaft	1
15	P 3306	Gasket	A/R
16	P 3695	Cover Plate and Bush	1
17	S 999	Spring Washer	1
18	P 3202	Adjuster Screw	1
19	P 3203	Nut	1
20	S 914	Bolt	4
21	S 902	Spring Washer	8
22	P 3342	Washer	2
23	S 948	Bolt	4
24	S 3907	Bottom Cap	1
25	P 3301	Shim	A/R
26	P 3341	Outer Race	2
27	PA 2733	Cage and Balls	2
28	P 3340	Cam	1
29	P 3309	Bush	2
30	P 2766	Oil Seal	1
31	P 2743	Plug	1
32	M 29629	Drop Arm	1
33	S 955	Spring Washer	1
34	S 9156	Nut	1

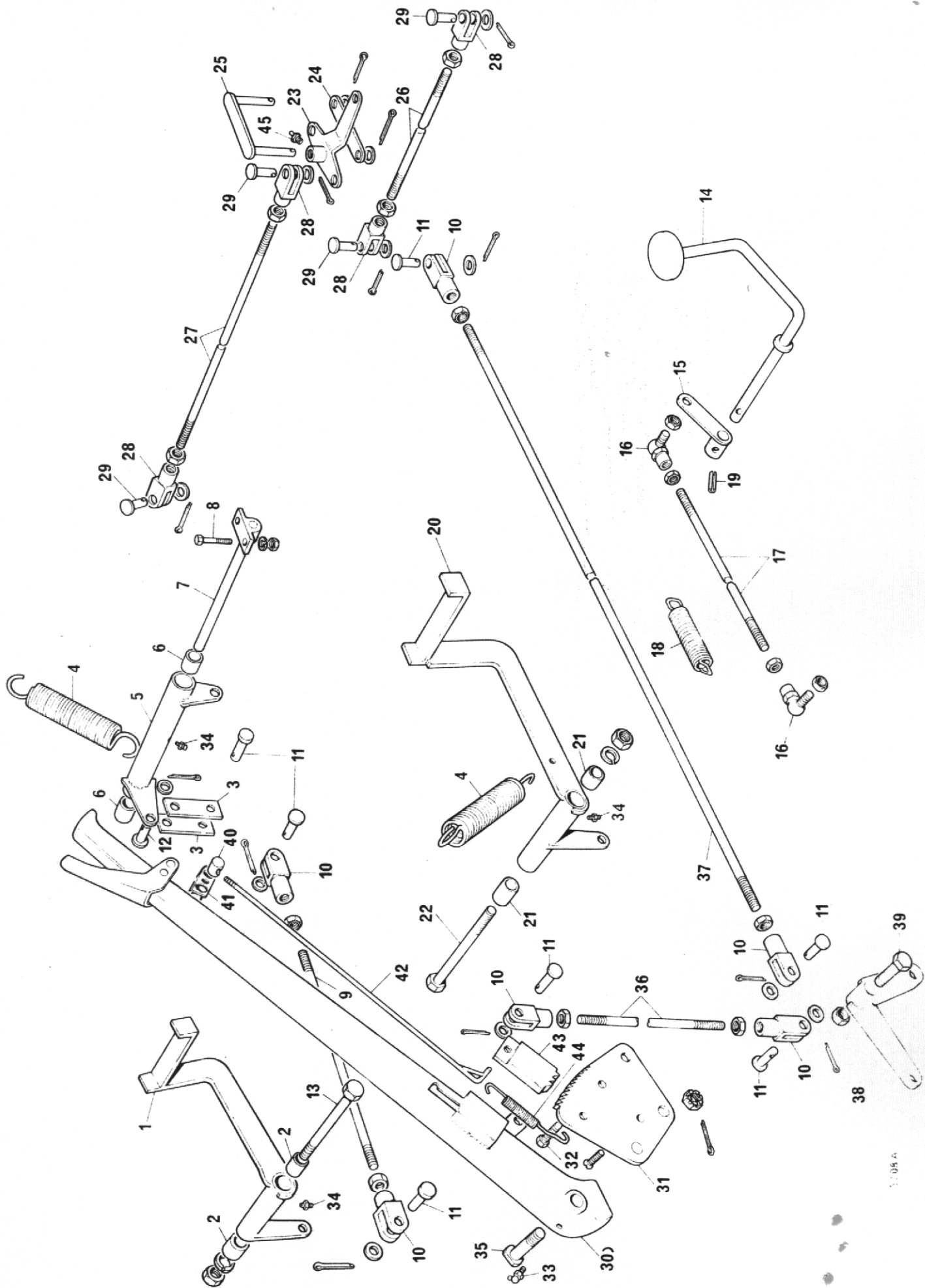

CLUTCH, HANDBRAKE AND FOOTBRAKE ASSEMBLY

Item No.	Part No.	Description	No. Off
1	5ST 13	Pedal, Clutch	1
2	WB1010	Bush, Clutch Pedal	2
3	F537	Link, Clutch Lever	2
4	C173 B	Spring, Return (Clutch and Footbrake Pedal)	2
5	F519	Lever, Clutch Transfer	1
6	WB0808	Bush, Transfer Lever (Clutch)	2
7	F519A	Rod, Clutch Transfer Lever	1
8		Nut and Bolt, 3/8" BSF x 1.1/4" Long	1
9	5ST21A	Rod, Clutch Adjusting	1
10	VBO 8360Y	Clevis	6
11	C174 X	Clevis Pin	7
12	5ST 101	Clevis Pin	1
13		Nut and Bolt 5/8" BSF x 4.1/2" Long	1
14	5ST 30	Pedal, Accelerator	1
15	F522	Lever, Accelerator (Petter PH2)	1
16	C160 B	Ball End, Accelerator Rod	2
17	5ST 22	Rod, Accelerator	1
18	C173 D	Spring, Return (Accelerator Rod)	1
19		Pin, Tension	1
20	5ST 12	Pedal, Footbrake	1
21	WB1212	Bush, Footbrake Pedal	2
22		Nut and Bolt, 3/4" BSF x 8" Long	1
23	5ST 76	Arm, Compensator Lever	1
24	C189 A	Link, Compensator	1
25	C271	Compensator Link Assembly	1
26	5ST20 A	Rod, Brake	1
27	5ST20 B	Rod, Handbrake	1
28	C174 C	Forkend	4
29	C174 Y	Clevis Pin	4
30	F517	Handbrake Lever Complete	1
31	F517 A	Quadrant, Handbrake Lever	1
32		Bolt, 5/16" BSF x 1" Long	2
33	T90	Nipple, Grease (90°)	1
34	TS	Nipple, Grease (Straight)	3
35	F517B	Bolt, Handbrake Carrier	1
36	5ST21 C	Rod, Lever Connecting	1
37	5SHD 54	Rod, Handbrake	1
38	LT292	Lever, Handbrake Transfer	1
39		Nut and Bolt, 5/8" BSF x 3.1/4" Long	1
40	000022/A	Pin, Latch Pivot Arm	1
41	14425 A	Arm, Latch Pivot	1
42	10291C	Rod, Handbrake Rod	1
43	6266A	Pawl, Handbrake Pawl	1
44	12873 A	Spring, Handbrake	1
45	5ST100	Grease Nipple	1

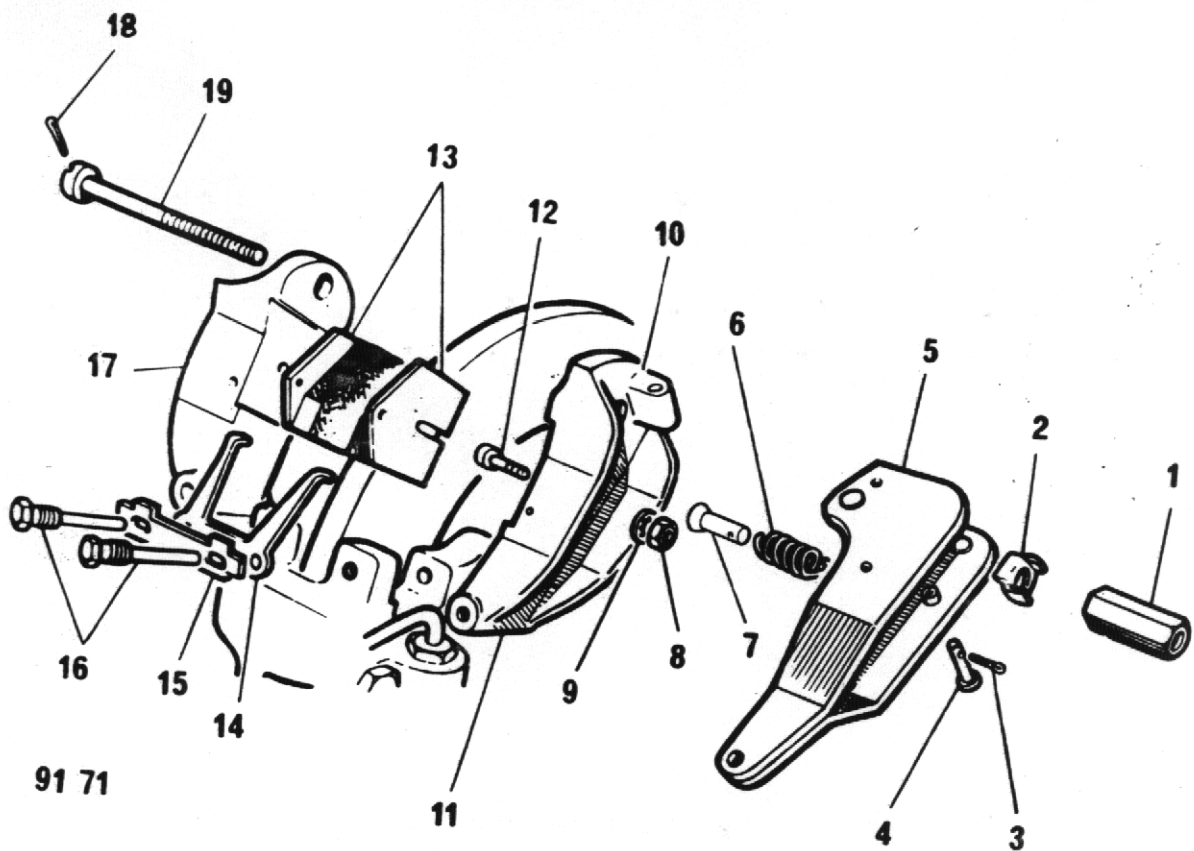

HANDBRAKE ASSEMBLY

Item No.	Part No.	Description	No. Off
1	CB20258	Nut, Adjustment	2
2	VBO8307	Spring, Friction	2
3	VBO6135D	Split Pin	2
4	VBO8315	Pin, Hinge	2
5	CB20526	Lever Assembly	2
6	VBO7329	Spring, Return	2
7	VBO7330	Spring Anchor	2
8	VBO6050	Nut 2BA	4
9	VBO6101F	Washer	4
10	VBO8308	Pivot Seat	2
11	CB60249/8308	Carrier Pad Assembly/Inner c/w Pivot Seat	2
12	VBC4124	Bolt	4
13	CB20311/Y	Friction Pad (4 per set)	1 set
14	VBM4635/1	Plate, Retraction	2
15	VBO4226	Washer, Tab	2
16	VBO4190	Bolt	4
17	VBM4573	Carrier Pad (Outer)	2
18	VBO6158/G	Split Pin	2
19	CB20289	Bolt	2
	CB90256	H/B Right Complete	1
	CB90257	H/B Left Complete	1

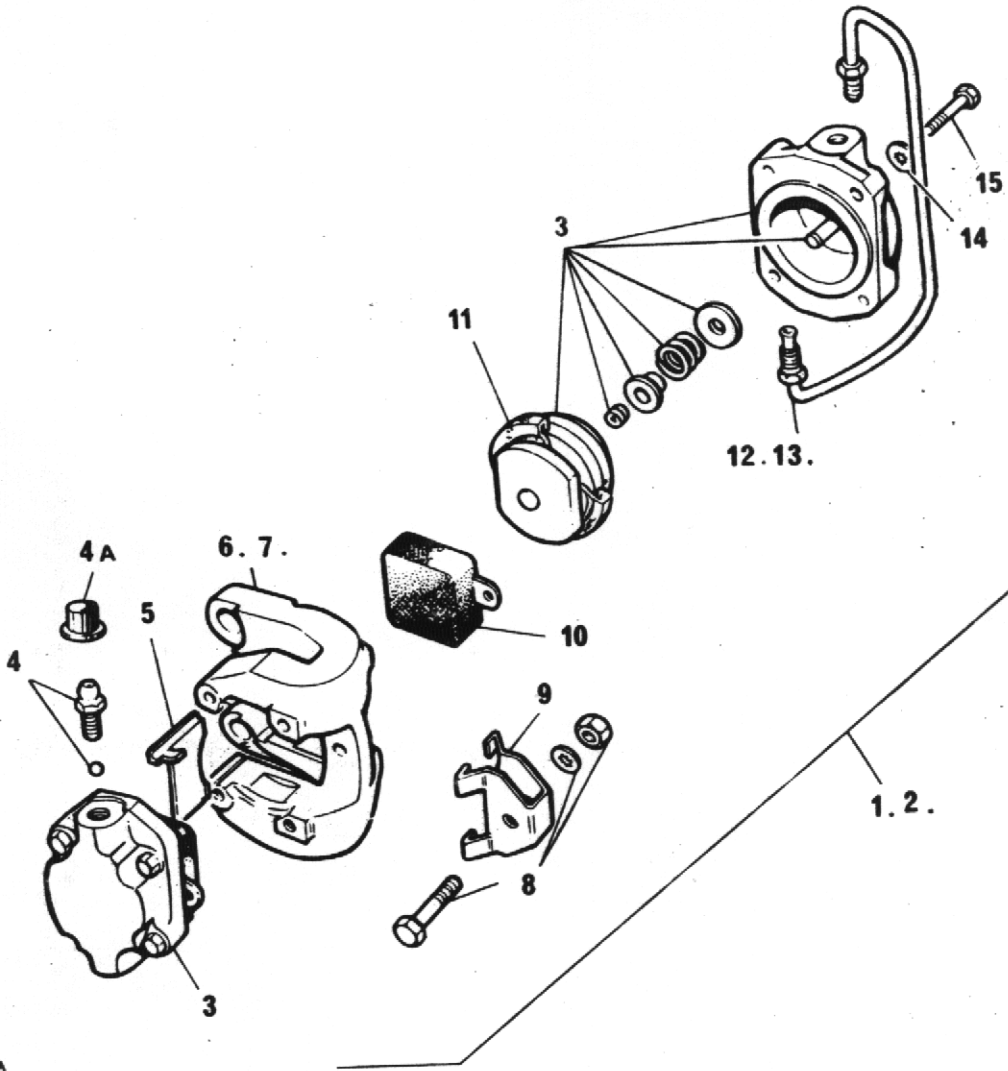

5873A

CALIPER ASSEMBLY

Item No.	Part No.	Description	No. Off
1	CB90262	Caliper Assembly Complete (LH)	1
2	CB90263	Caliper Assembly Complete (RH)	1
3	VB05505	Piston and Cylinder Assembly	4
4	VB08378	Bleed Screw and Ball Assembly	2
4A	CB0849	Dust Cover (Bleedscrew)	2
5	VB05133	Plate, Support	4
6	CB60253	Body, Caliper (RH)	1
7	CB60252	Body, Caliper (LH)	1
8	VB08491	Nut, Bolt and Washer (Keep Plate)	2
9	VB05123	Keep Plate	2
10	VB08360Y	Friction Pad Complete (Set of 4)	1
11	VB08210A	Seal Kit (Dust and Piston)	4
12	VB03927	Bridge Pipe Assembly (RH)	1
13	VBO3926	Bridge Pipe Assembly (LH)	1
14	VB0610L	Washer, Shakeproof	16
15	VB05100	Bolt, Retaining (Cylinder)	16

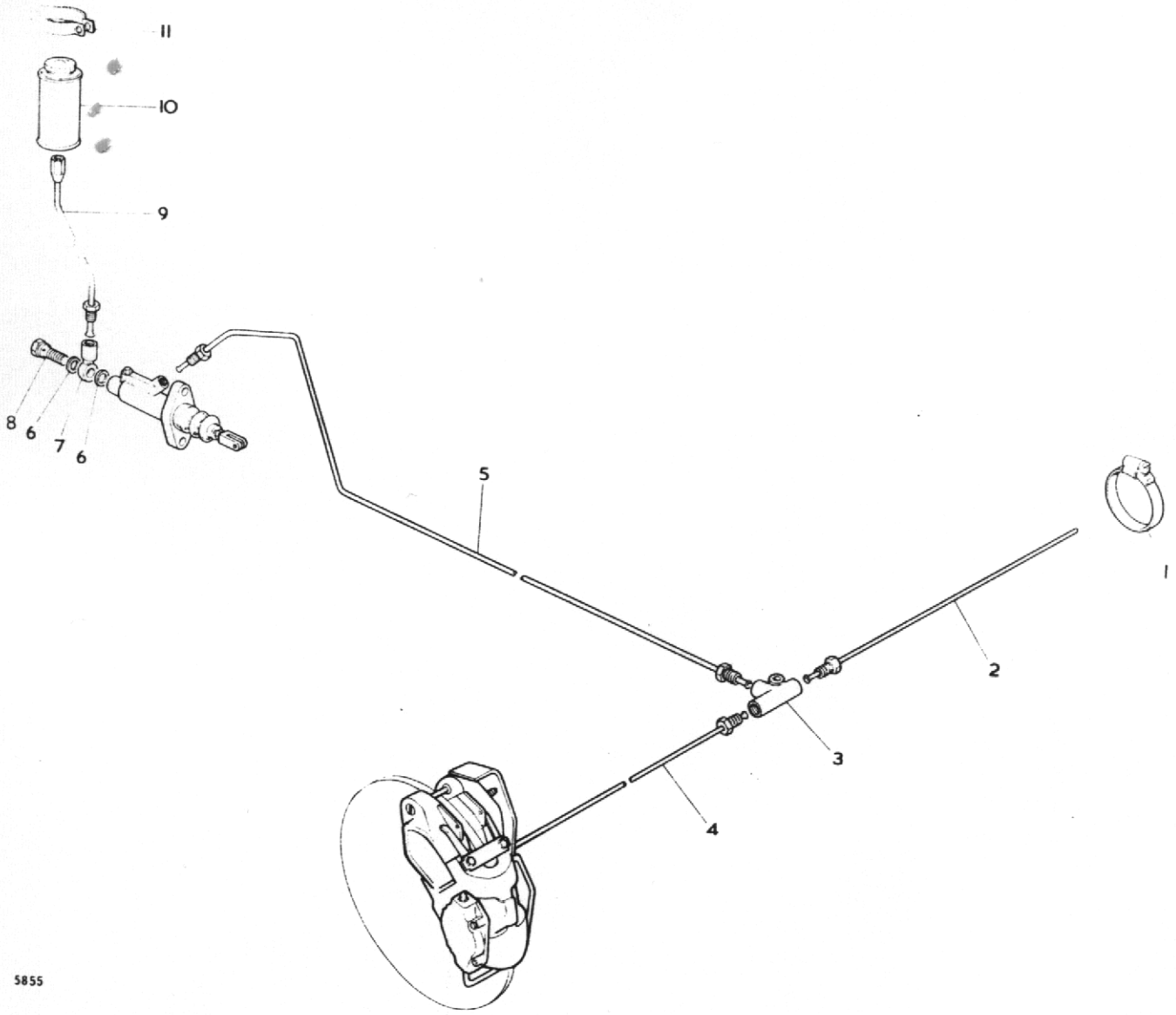

5855

HYDRAULIC BRAKE SYSTEM

<i>Item No.</i>	<i>Part No.</i>	<i>Description</i>	<i>No. Off</i>
1	4-350 S	Hose Clip	4
2	64474422	Pipe (45")	1
3	64474341	Tee Piece	1
4	64473383	Pipe (21")	1
5	64475767	Pipe (81")	1
6	378700	Washer	2
7	64474291	Banjo	1
8	644703063	Banjo Bolt	1
9	3424240 W	Pipe (21")	1
10	64047211	Header Tank	1
11	378620	Clip	1

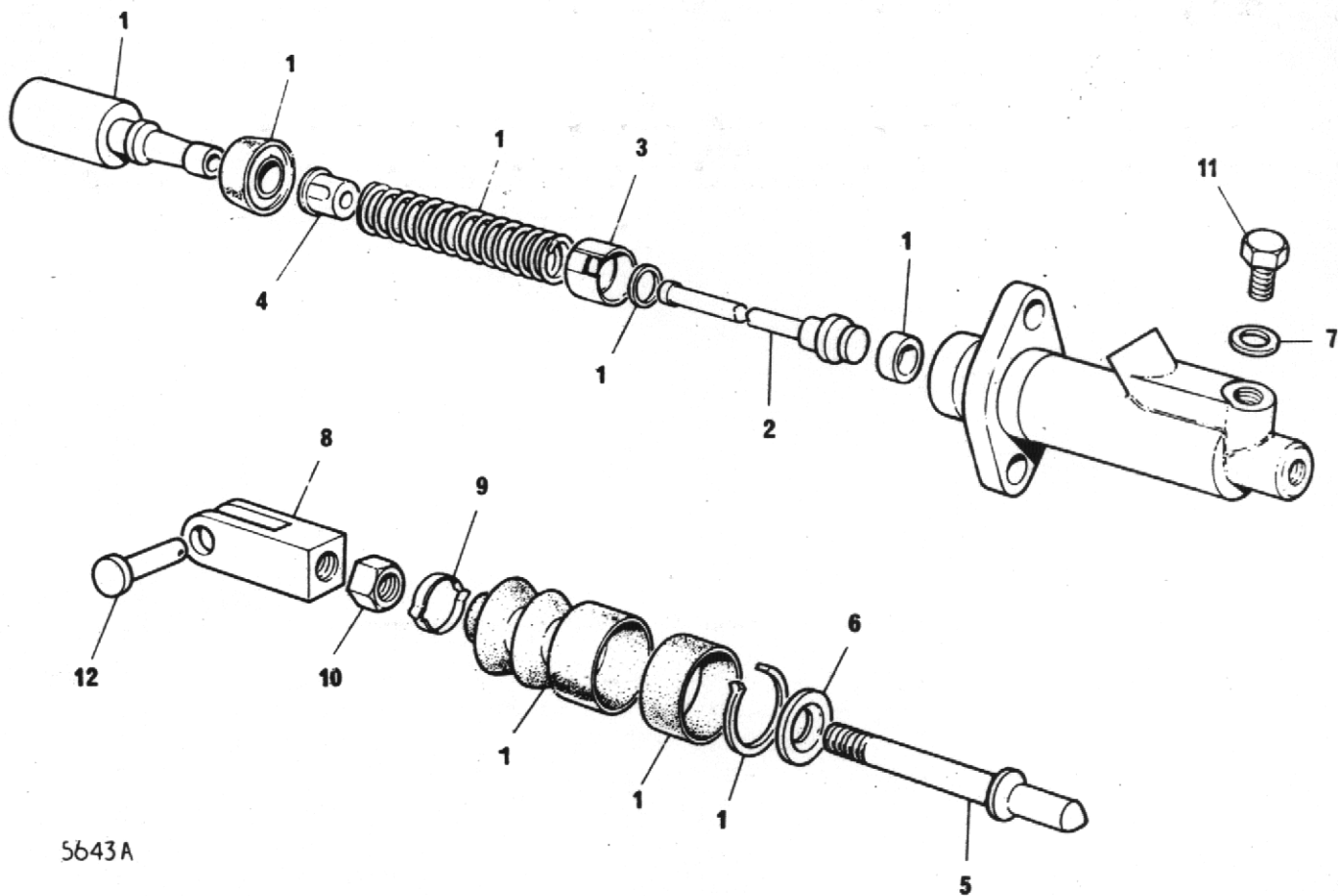

5643A

MASTER CYLINDER

<i>Item No.</i>	<i>Part No.</i>	<i>Description</i>	<i>No. Off</i>
	64067970	Master Cylinder Complete	1
1	SP 1996-2	Seal Kit	1
2	378641	Valve Stem	1
3	318001	Valve Spacer	1
4	64673391	Valve Spring Retainer	1
5	351257W	Push Rod	1
6	378242	Retaining Washer	1
7	378700	Washer	1
8	64671286	Clevis	1
9	378312	Dust Cover Retainer	1
10	64100052	Lock Nut	1
11	64110348	Plug	1
12	C 174 Y	Clevis Pin	1

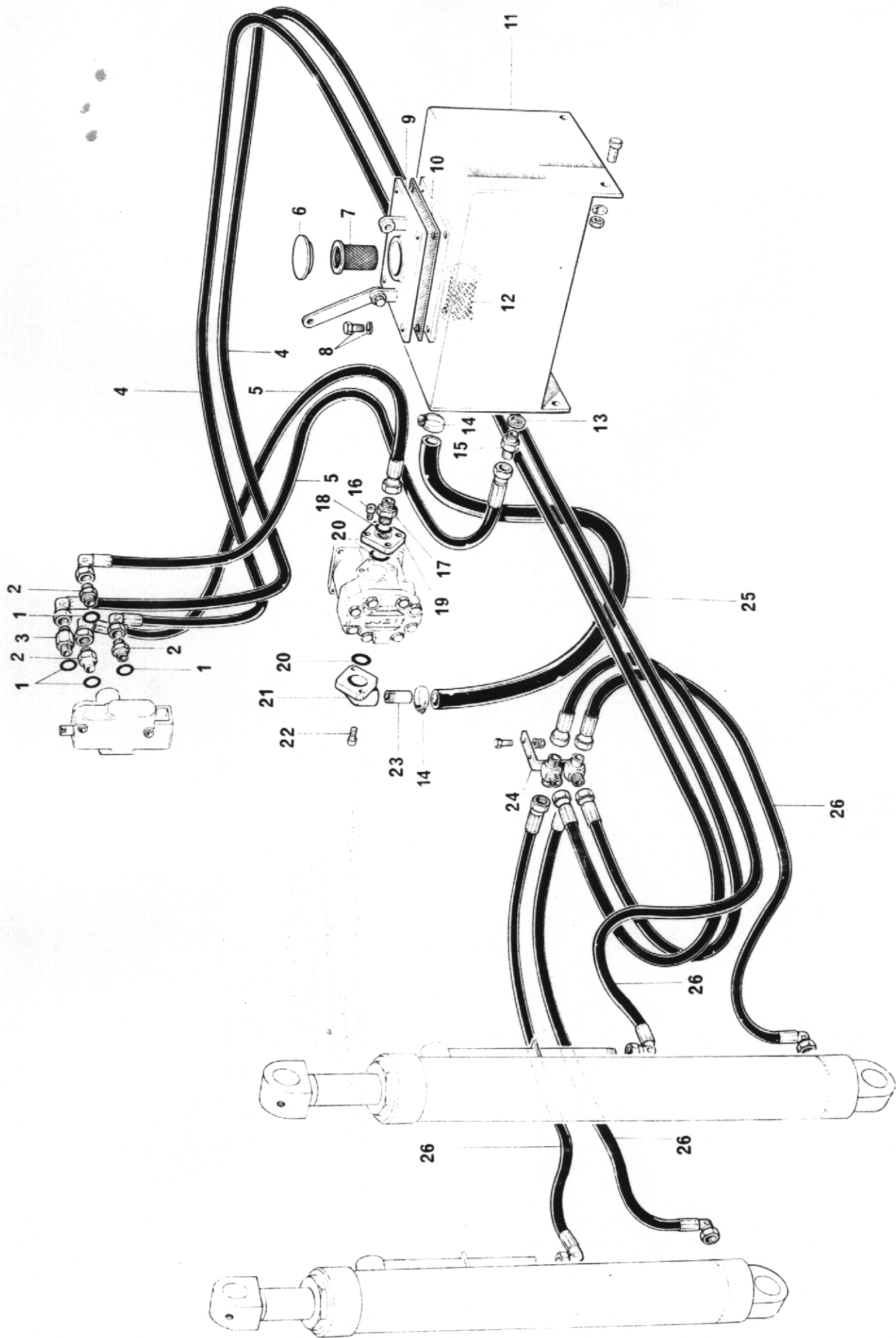

HYDRAULIC HOSES & FITTINGS

<i>Item No.</i>	<i>Part No.</i>	<i>Description</i>	<i>No. Off</i>
1	2ST 72 J	'O' Ring	4
2	4-35-40 K	3/4" Jic x 3/8" BSP Adaptor	3
3	4-60-115	3/4" Jic x 3/8" BSP Adaptor (Long)	1
4	T 63 C	Hose	2
5	T 63 E	Hose	2
6	P2578-2	Cap	1
7	P1145	Strainer	1
8		Bolt 5/16" UNF x 3/4" Long and Washer	4
9	4-35-187	Cover Plate Assembly	1
10	T 18 B	Gasket	1
11	2ST118	Tank	1
12	UC 1457	Filter	1
13	T 14 I	Sealing Washer	1
14	T 63 M	Hose Clip	2
15	T 14 J	3/8" BSP x 3/8" BSP Adaptor	1
16		Capscrew 5/16" UNF x 1" Long	4
17	T 63 K	3/8" BSP x 1/2" BSP Adaptor	1
18	T 14 H	1/2" Sealing Washer	1
19	PD 4352-21 A	Pump Outlet	1
20	DH 25-19	'O' Ring Seal	2
21	EP 2 A 2	Pump Elbow	1
22		Capscrew 5/16" UNF x 1.1/4" Long	2
23	T 48	Pump Inlet	1
24	5ST 93	Hydraulic Connector	1
25	5ST 95-5	Hose - 3/4" Cotton Braided, 3'-7" Long	1
26	4-35-179	Hose	4

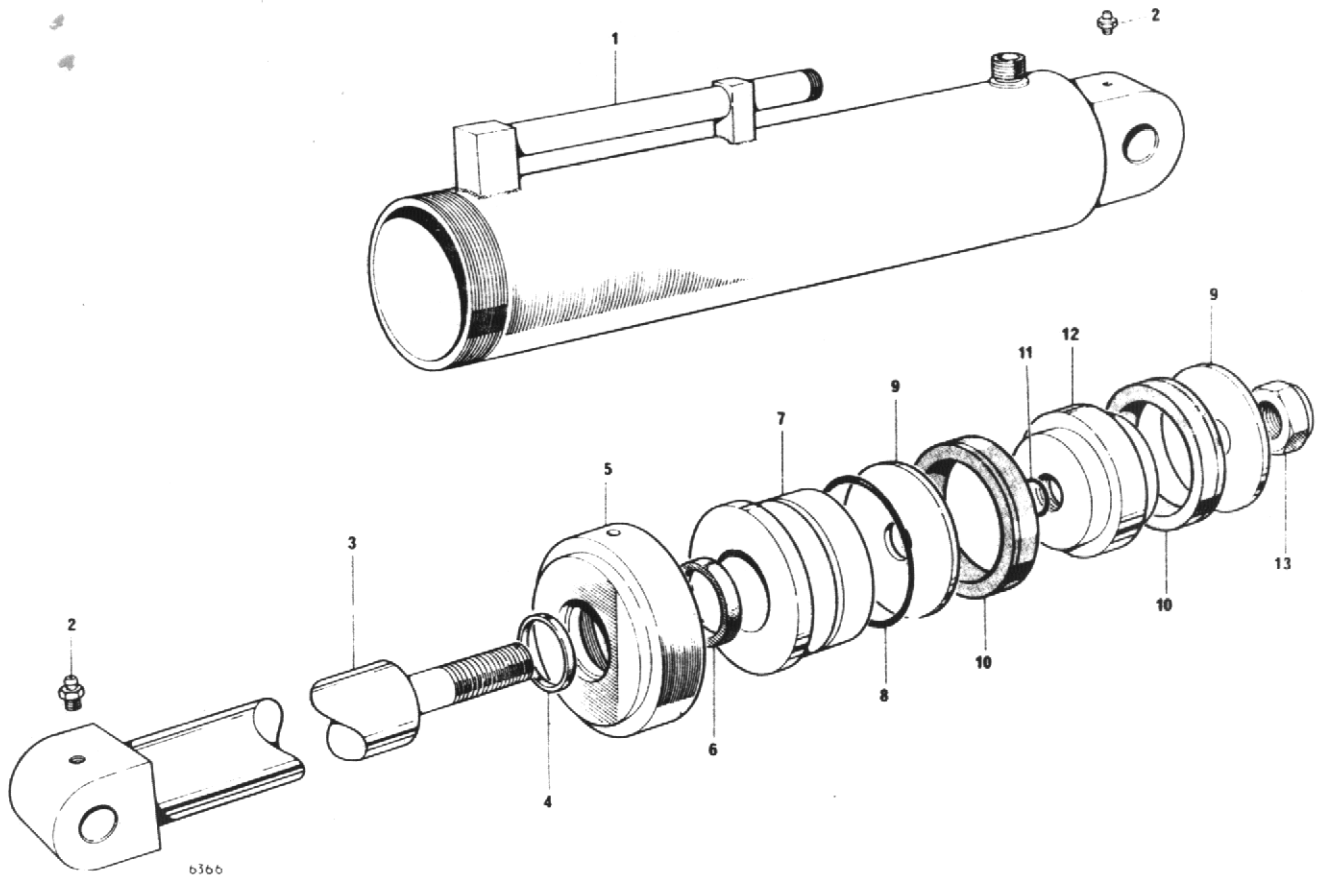

TIPPING CYLINDER

Item No.	Part No.	Description	No. Off
	30162A01	Cylinder Assembly Complete (Two per M/C)	
1	30162A0101	Cylinder Body	1
2	131808	Grease Nipple	2
3	BE3-22	Piston Rod Assembly	1
4	30162A0104	Wiper	1
5	30162A0105	Tube Cap	1
6	30162A0106	Sleeve Seal	1
7	30162A0107	Sleeve	1
8	49819	Sleeve 'O' Ring	1
9	BE3-10	Backing Washer	2
10	BE3-14	Piston Seal	2
11	49818	Piston 'O' Ring	1
12	30162A0112	Piston Head	1
13	BE3-11	Lock Nut	1

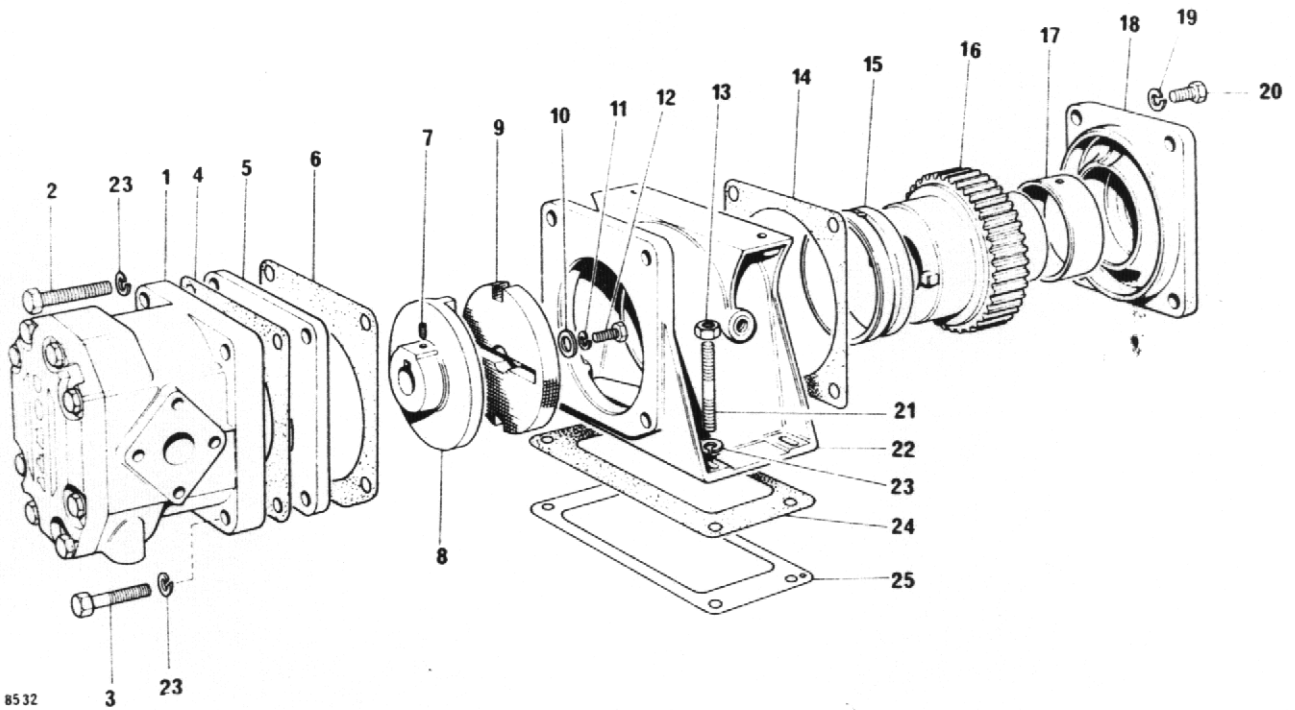

HYDRAULIC PUMP AND DRIVE GEAR

Item No.*	Part No.	Description	No. Off
1	GP265CU	Pump	1
2	NSD110	Bolt 3/8" x 2.1/2" Long	2
3	NSD110	Bolt 3/8" x 2" Long	2
4	263871	Joint	1
5	266158	Plate, Spigot	2
6	266159	Joint	2
7	NSD840	Screw, Socket 1/4" x 3/8" Long	1
8	266156	Coupling, Pump	1
9	265413	Block, Coupling	1
10	264705	Washer, Plain	1
11	NSD137	Washer, Spring x 1/4"	1
12	NSD1004	Set Screw, Pump Shaft 1/4" UNF x 1/2" Long	1
13	NSD20	Nut 3/8"	6
14	264702	Joint	1
15	2-264704	Bearing Housing	1
16	2-264703	Gearwheel	1
17	2-202485	Bush, Housing	1
18	264701	Cover, Pump Housing	1
19	NSD137	Washer, Spring x 5/16"	4
20	NSD111	Set Screw 5/16" x 5/8" Long	4
21	NSD60	Stud 3/8" x 1.1/2"	4
22	2-197597	Housing, Pump	1
23	NSD137	Washer, Spring x 3/8"	8
24	264700	Joint	1
25	264706	Shim	1

A/R

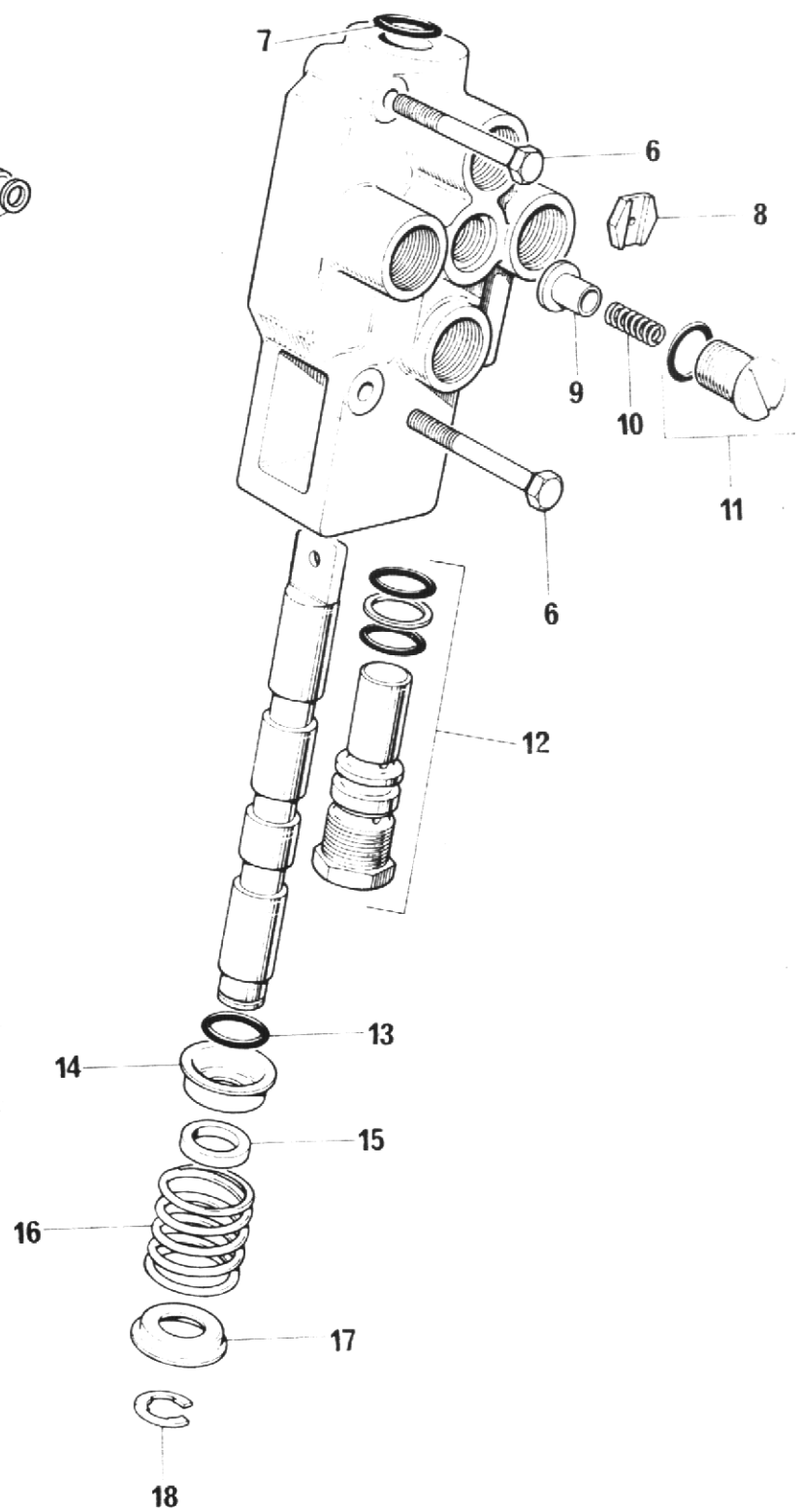
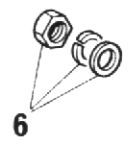
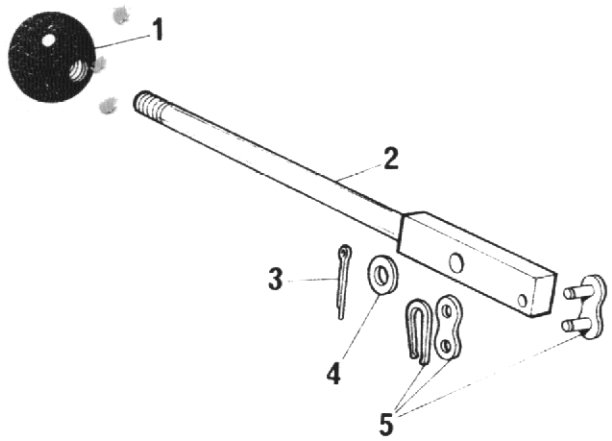

8751

HYDRAULIC CONTROL VALVE

<i>Item No.</i>	<i>Part No.</i>	<i>Description</i>	<i>No. Off</i>
	300-024-AAD	Hydraulic control Valve	1
1	2ST 88	Control Knob	1
2	4-60-143	Valve Control Lever	1
3		Cotter, Split	1
4		Washer, Plain	1
5	4-60-178	Connecting Link	1
6		Bolt 5/16" UNF x 2.1/2" Long, Nut and Washers	2
7	16004-63	'O' Ring	1
8	16097-451	Orifice Plate	1
9	30501-12	Lift Check Plunger	1
10	30501-13	Lift Check Spring	1
11	30501-17	Lift Check Plug Assembly	1
12	32018-L9	Relief Valve Assembly	1
13	16003-12	'O' Ring 3/32" Dia. x 5/8" i/d	1
14	30501-10	Deep Washer	1
15	16048-31	Washer, Spacer	1
16	30501-39	Spool Spring	1
17	15546-6	Shallow Washer	1
18	16124-50	Clip Ring 1/2" Shaft	1

DECIMAL, FRACTIONAL AND METRIC EQUIVALENTS

Inches		Milli- metres	Inches		Milli- metres
Fractions	Decimals		Fractions	Decimals	
1/64	0.015625	0.397	33/64	0.515625	13.097
1/32	0.03125	0.794	17/32	0.53125	13.494
3/64	0.046875	1.191	35/64	0.546875	13.891
1/16	0.0625	1.588	9/16	0.5625	14.288
5/64	0.078125	1.984	37/64	0.578125	14.684
3/32	0.09375	2.381	19/32	0.59375	15.081
7/64	0.109375	2.778	39/64	0.609375	15.478
1/8	0.125	3.175	5/8	0.625	15.875
9/64	0.140625	3.572	41/64	0.640625	16.272
5/32	0.15625	3.969	21/32	0.65625	16.669
11/64	0.171875	4.366	43/64	0.671875	17.066
3/16	0.1875	4.763	11/16	0.6875	17.463
13/64	0.203125	5.159	45/64	0.703125	17.859
7/32	0.21875	5.556	23/32	0.71875	18.256
15/64	0.234375	5.953	47/64	0.734375	18.653
1/4	0.250	6.350	3/4	0.750	19.050
17/64	0.265625	6.747	49/64	0.765625	19.447
9/32	0.28125	7.144	25/32	0.78125	19.844
19/64	0.296875	7.541	51/64	0.796875	20.241
5/16	0.3125	7.938	13/16	0.8125	20.638
21/64	0.328125	8.334	53/64	0.828125	21.034
11/32	0.34375	8.731	27/32	0.84375	21.431
23/64	0.359375	9.128	55/64	0.859375	21.828
3/8	0.375	9.525	7/8	0.875	22.225
25/64	0.390625	9.922	57/64	0.890625	22.622
13/32	0.40625	10.319	29/32	0.90625	23.019
27/64	0.421875	10.716	59/64	0.921875	23.416
7/16	0.4375	11.113	15/16	0.9375	23.813
29/64	0.453125	11.509	61/64	0.953125	24.209
15/32	0.46875	11.906	31/32	0.96875	24.606
31/64	0.484375	12.303	63/64	0.984375	25.003
1/2	0.500	12.700	1	1.000	25.400

INCHES INTO MILLIMETRES

Inches	0	1	2	3	4	5	6	7	8	9
0	0	25.40	50.80	76.20	101.60	127.00	152.40	177.80	203.20	228.60
10	254.00	279.40	304.80	330.20	355.60	381.00	406.40	431.80	457.20	482.60
20	508.00	533.40	558.80	584.20	609.60	635.00	660.40	685.80	711.20	736.60
30	762.00	787.40	812.80	838.20	863.60	889.00	914.40	939.80	965.20	990.60
40	1016.00	1041.40	1066.80	1092.20	1117.60	1143.00	1168.40	1193.80	1219.20	1244.60
50	1270.00	1295.40	1320.80	1346.20	1371.60	1397.00	1422.40	1447.80	1473.20	1498.60
60	1524.00	1549.40	1574.80	1600.20	1625.60	1651.00	1678.40	1701.80	1727.20	1752.60
70	1778.00	1803.40	1828.80	1854.20	1879.60	1905.00	1930.40	1955.80	1981.20	2006.60
80	2032.00	2057.40	2082.80	2108.20	2133.60	2159.00	2184.40	2209.80	2235.20	2260.00
90	2286.00	2311.40	2336.80	2362.20	2387.60	2413.00	2438.40	2463.80	2489.20	2514.60

Use in conjunction with above table.

Example: Find equivalent mm. for 84 5/8".

$$84'' = 2133.60 \text{ mm.}$$

$$5/8'' = 15.875 \text{ mm.}$$

$$84 \text{ } 5/8'' = 2149.475 \text{ mm.}$$

CALIFORNIA

Proposition 65 Warning

Diesel engine exhaust and some of its constituents are known to the State of California to cause cancer, birth defects, and other reproductive harm