

WINGET

OPERATORS HANDBOOK TD500 & TD500HL TRACKED DUMPER

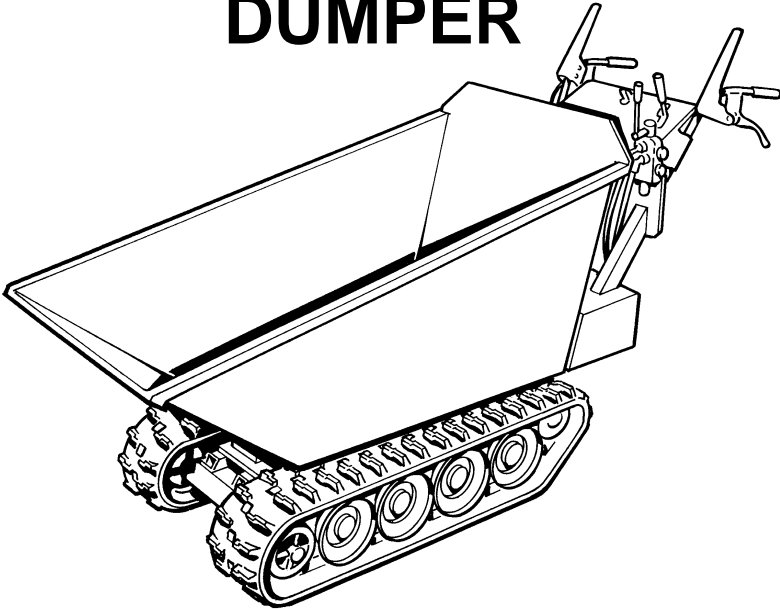

WINGET LIMITED
PO BOX 41
EDGEFOLD INDUSTRIAL ESTATE
PLODDER LANE
BOLTON
LANCS
BL4 0LR

Tel: ++ 44 (0) 1204 854650
parts@winget.co.uk
service@winget.co.uk
www.winget.co.uk

ISSUE 11 2017

CONTENTS

- 1 Introduction**
- 2 Declaration of Conformity**
- 4 Warranty Terms & Conditions**
- 6 Safe Working**
- 11 Operation**
- 13 Maintenance and Service**
- 20 Technical Information**
- 23 Parts Information**

The WINGET TD500 & TD500HL Tracked Dumper are based on the HONDA HP500H Power Carrier donor unit and this Handbook must be read in conjunction with HONDA HP500H Owners Manual.

The contents of this Handbook although correct at the time of publication, may be subject to alteration by the manufacturers without notice.

Winget Limited operates a policy of continuous product development. Therefore, some illustrations or text within this publication may differ from your machine.

WARNING: The operator must read both this handbook and the Honda publication and be familiar with all the controls before attempting to operate this machine.

DECLARATION OF CONFORMITY

WINGET

WINGET LIMITED
Registered in England No. 1977110

Registered Office:
P.O. Box 41
Edgefold Industrial Estate
Plodder Lane
Bolton Lancs. BL4 0LS

Tel: (01204) 854650
Fax: (01204) 854663 Parts/Purchasing
Fax: (01204) 854664 Winget Sales
Fax: (01204) 854663 Croker Sales
Fax: (01204) 854663 Service/Engineering
Fax: (01204) 854620 Accounts Enquiries
E mail: service@winget.co.uk
Web Site: www.winget.co.uk

We: WINGET LIMITED

Of P.O. Box 41 Edgefold Industrial Estate, Plodder Lane, Bolton, Lancs,
England BL4 0LR declare that the product type:-

Machine Type:- 500Kg Tracked Dumper

Model:- TD500 & TD500HL

Serial Number:- TD5001001-TD5002599

To which this declaration relates, with a net installed power of 3.6Kw and
having been tested in accordance with the Conformity Assessment Procedure
detailed in Annexe VI of Directive 2000/14/EC and verified by:-

AV Technology Limited
AVTECH House
Birdhall Lane
Cheadle Heath
Stockport
Cheshire
SK3 0XU

is in conformity with the provisions of the Noise Emission in the Environment
by Equipment for use Outdoors Directive 2000/14/EC. A representative sample
of this equipment was tested and Sound Power Levels (L_{wa}) recorded of:-

99db

We guarantee under the provisions of the above Directive (2000/14/EC) that
the Sound Power Levels for this equipment will not exceed:-

101db

We also declare that the above equipment is also in accordance with the following EC Directives:-

2006/42/EC

2004/108/EC

Bolton 29.03.17

Place and date of issue

S. Hodge



Name and signature or equivalent marking of authorised person.

Joint Managing Director

Position

The above named person is also responsible for holding the Technical Documentation applicable to the product to which this declaration relates and may be contacted at the address which appears at the head of this declaration

Please take care of this document, as duplicate copies are not available.

This document is in accordance with EN45014:1989

Winget Limited assures you that if any of the parts identified within the Parts section of this manual become defective due to faulty manufacture or materials within 12 months from the date of purchase, the part will be repaired or replaced under warranty free of charge by any authorised Winget Distributor.

Warranty repairs *must* be carried out by a Winget Distributor, unless prior agreement has been agreed in writing with the Warranty Department at Winget Limited.

This warranty is given to the first owner and may be transferred to subsequent owners for the balance of the Warranty period.

Winget Limited's liability only extends to the costs of repair or replacement of the faulty parts and necessary labour charges involved in the repairs. The company accepts no liability for any consequential loss, damage or injury, resulting directly or indirectly from any defect in the goods.

Items not covered by Warranty and considered to be the customers responsibility include normal maintenance services; replacement of service items and consumables; replacement required due to abuse, accident, misuse or improper operation; replacement of wearable items e.g. pins bushes etc.

All Warranty repairs on the Honda HP500H Power Carrier must be carried out by an Authorised Honda Distributor.

The Warranty will not apply where the equipment is modified, converted, or used for purposes other than those for which it was designed, unless clearance for the modifications etc. have been granted by Winget Limited in writing.

The Pre-delivery Inspection & Warranty Registration Document must be completed correctly and returned to Winget Limited within 7 days of the date of sale. Failure to do so could result in any subsequent Warranty claim being rejected.

No claim will be considered if other than genuine Winget Limited parts, which must be obtained via an authorised Winget distributor,

are used to effect a repair, or if lubricants other than those recommended by Winget Limited are used.

The equipment must be serviced and maintained in accordance with the service schedules laid down in this handbook by Winget Limited. Evidence that these have been complied with may be required before Warranty claims are reimbursed.

Winget Limited have a policy of continuous product improvement and reserve the right to change specifications without notice. No responsibility will be accepted for discrepancies, which may occur between the specification of machines and the descriptions contained in publications.

Safety is the responsibility of all persons working with and around this machine. Think “SAFETY” at all times. *Read and remember the contents of this and the Honda Operators Handbook.*

Any modifications to the machine will affect its working parameters and reduce built in safety factors. Refer to Winget Limited before fitting any non-standard equipment or parts. Winget Limited accepts no responsibility for any modifications made after the machine has left the factory, unless previously agreed in writing. Winget Limited will accept no liability for damage to property, persons or the machine if failure is brought about due to such modifications, or fitment of spurious parts.

***Never* use this machine for purposes other than those for which it was designed. This machine was designed to carry loads such as soil, clay, sand, wet concrete, light stone, garden rubbish or other similar materials. It was not designed to carry any loads or materials that may over hang the skip in any way, nor was it designed to carry loads that may move around in the skip uncontrollably. If in doubt as to the suitability of this machine for a particular task refer to Winget Limited or Honda Power Equipment.**

***Never* commence work until the daily service checks have made carried out.**

***Always* report faults as soon as they are discovered.**

***Never* fill fuel or hydraulic tanks whilst the engine is running. Stop the engine and allow the tanks to cool.**

***Never* leave the machine unattended with the engine running.**

***Never* ride on the machine and do not carry others as passengers.**

***Never* use this equipment in areas of poor lighting.**

***Always* operate on surfaces that are known to be stable.**

***Never* drive or operate the machine close to the edge of any excavation, *always* use effective track stops to prevent the machine running close to the edge. Ensure the stops are in proportion to the size of the tracks and are set sufficiently far back from the edge of any excavation to prevent the weight of the load causing a collapse.**

Never work under an unsupported or unpropped skip or scissors.

Always ensure that any load is evenly distributed in the skip.

Never carry loads or heap material in such a manner as to effect forward vision.

Always take care when tipping non free running loads, be aware that wet concrete when carried in a skip can settle and stick in the skip when tipped thereby affecting the centre of gravity and stability.

Never use the skip in a tipped position to bulldoze heaped materials level or backfill material into excavations.

Never tip the skip or raise the scissors to discharge materials unless on firm level ground.

Never tip the skip unless the machine is stationary and the clutch levers have been released.

Never exceed the rated payload, this machine is designed to carry 500kg on level ground, this should be reduced to 350kg when operating on gradients.

Never operate on any downward gradient which exceeds 15° or on any upward gradient which exceeds 20°

Always walk behind the machine on gradients, never in front of it; do not reverse down gradients.

Always remember that slippery or loose surface conditions can adversely affect the safe operation of this machine.

Never attempt to turn on or cross a gradient.

Never smoke whilst filling the fuel tank, mop up any fuel spills immediately and in any event before running the engine and allow time for any vapours from the spilled fuel to disperse before starting the engine.

Never run the engine in an enclosed or confined area, exhaust fumes in enclosed areas can kill.

Always avoid contact with the exhaust muffler, this can get very hot when the engine is running and remains so for some time afterwards.

Always “dump” residual hydraulic pressure from the system before leaving the machine. Lower the skip and scissors; stop the engine, then move the hydraulic control lever(s) several times in each direction.

Never leave the machine unattended with pressure in the hydraulic system.

Always, where possible, work on or close to engines or machinery when carrying out servicing or any maintenance, only when they are stopped, if this is not practical, remember to keep tools, test equipment and all parts of your person well away from moving parts.

Always wear correctly fitting clothing when carrying out servicing, loose or baggy clothing can be extremely dangerous when working on running engines or machinery.

Always “dump” pressure from the hydraulic system before carrying out any kind of maintenance or adjustment.

Never allow unqualified personnel to attempt to repair, remove or replace any part of the machine.

Always obtain advice before mixing oils; some are incompatible, if in doubt completely drain, flush and refill.

Many liquids used in this machine are harmful if taken internally or splashed into the eyes. In the event of accidentally swallowing oils or fuels, seek qualified medical assistance and advice.

Always dispose of waste oils and fuels into designated waste oil storage tanks. If storage tanks are not available, consult your distributor or local authority for the addresses of local designated disposal points. Improperly discarded waste oils pose a threat to wildlife. It is illegal to dispose of waste oil into drains, or water courses or to bury it. The Environment Agency have the power to impose heavy fines for breaches of the above advice.

Never allow oils and fuels to come into regular contact with skin. This can lead to serious skin diseases, including, medical evidence

suggests, skin cancer. **ALWAYS** wear protective gloves when handling oils and fuels whether topping up, draining or refilling. **ALWAYS** wash your hands if oils or fuels come into contact with the skin.

Always store fuels in small quantities in the correct specially designed containers, which can be securely fastened. Store fuel in a cool, well ventilated store away from sources of ignition.

Always ensure that any Warning, Safety or Advisory Decals attached to the machine are legible and clean, replace if damaged, defaced or missing.

The following warning and advisory decals are applied to the dumper

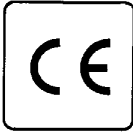

'CE' Decal



Wear Eye Protection

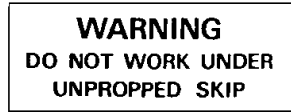

Do Not Work Under Skip



Hydraulic Control
(Not "HL")

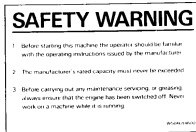

Safety Reminder



Hydraulic Oil



Keep Hands Clear



Reads Ops Book

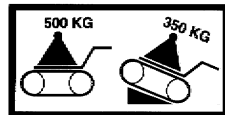

Load Carrying Capacity

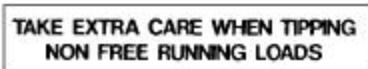

Take Care With Non Free Running Loads

The following additional advisory decals are applied to the 'HL' model



Do Not Track

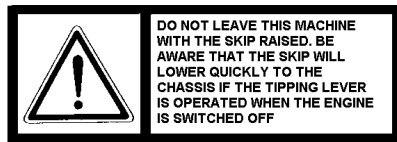

Do Not Leave Machine with Skip Raised

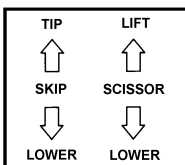

Hydraulic Control Functions

***Never* commence work until the daily service checks have been carried out.**

***Only* tip or discharge the skip on level ground.**

The hydraulic system control valve and operating lever is mounted on top of the hydraulic tank on the left-hand side of the machine.

The operating lever has three positions, forwards for 'Dump' or 'Tip', centre for 'Neutral' or 'Hold' and rearwards for 'Return'.

The hydraulics will not operate until the engine is running, although it is possible to lower a raised skip without engine power by moving the hydraulic control lever to the 'Dump' position. For this reason do not leave the machine unattended with the skip raised. Refer to the Honda HP500H Operators Handbook for instructions on starting the engine.

With the engine running and the engine speed set to fast idle push the lever forwards as indicated on the 'Dump/Return' Decal located top of the fuel tank. The rate of oil delivered to the skip tipping ram and therefore the speed at which the skip tips is proportional both to the distance the lever is moved and the speed at which the engine is set.

Holding the lever forwards until the skip reaches the maximum travel of the ram will cause the relief valve located in the control valve to 'blow off' allowing the oil to return to tank. Do not hold the lever forward when the 'relief valve' blows, this will cause the hydraulic oil temperature to increase and may cause damage to components. Once the ram reaches the end of its travel release the lever to the neutral or hold position.

Releasing the operating lever will allow it to automatically return to neutral position and movement of the skip will stop, even if the ram has not reached the full extent of its travel, or the skip is not seated on the stops. In this way once you are used to the controls, the speed at which the skip will tip can be finely controlled.

Once the skip is empty pull the lever to the rear and allow the skip to return down on to the skip stops. Do ***NOT*** allow the skip to return onto the stops with any force, control the speed of its return using

the operating lever and gently bring the skip back onto to stops. This is particularly important if you have not completely emptied the skip.

Allowing the skip to return onto the stops with force will damage the machine.

Holding the lever to the rear until the skip is fully lowered will cause the relief valve located in the control valve to 'blow off' allowing the oil to return to tank. Do not continue to hold the lever rearward when the 'relief valve' blows off, this will cause the hydraulic oil temperature to increase and may cause damage to components. Once the skip is seated on the stops release the operating lever to the neutral position.

Never commence work until the daily service checks have been carried out.

Only tip or discharge the skip or raise the scissors on level ground.

The hydraulic system control valve and operating levers are mounted on top of the hydraulic tank on the left-hand side of the machine.

The inner lever controls the scissor operation whilst the outer lever controls the skip tipping functions, the function of each lever is indicated on the decal on the rear of the valve mounting plate.

The operating levers have three positions, forwards for 'Scissor Lift' or 'Skip Tip', centre for 'Neutral' or 'Hold' and rearwards for 'Scissor Lower' or 'Skip Return'.

The hydraulics will not operate until the engine is running, although it is possible to lower a raised skip or scissors without engine power by moving the operating levers to the 'Dump' or 'Lower' positions. For this reason the machine should not be left unattended with either the skip or scissors raised. Refer to the Honda HP500H Operators Handbook for instructions on starting the engine.

With the engine running and the engine speed set to fast idle, refer to the decal on the rear of the valve mounting plate and identify the lever controlling the function required, slowly push the lever forwards. The rate of oil delivered to the skip tipping or scissor ram and therefore the speed at which the skip tips or the scissors lift is proportional both to the distance the lever is moved and the speed at which the engine is set.

Holding the lever forwards until the skip or scissors reaches the maximum travel of the ram will cause the relief valve located in the control valve to 'blow off' allowing the oil to return to tank. Do not hold the lever forward when the 'relief valve' blows, this will cause the hydraulic oil temperature to increase and may cause damage to components. Once the ram reaches the end of its travel release the lever to the neutral or hold position.

Releasing the operating lever will allow it to automatically return to neutral position and movement of the skip or scissors will stop, even if the ram has not reached the full extent of its travel, or the skip is

not seated on the stops or the scissors not completely lowered. In this way once you are used to the controls, the speed at which the skip will tip or the scissors raised or lowered can be finely controlled.

Once the skip is empty pull the outer lever to the rear and allow the skip to return down on to the skip stops. Move the inner lever to the rear and lower the scissors to the rest position.

Do *NOT* allow the skip or scissors to return onto the stops or rest position with any force, control the speed of their return using the operating lever and gently bring the skip back onto to stops or lower the scissors to the rest position. This is particularly important if you have not completely emptied the skip.

Allowing the skip or scissors to return onto the stops or rest position with force will damage the machine.

Holding the lever to the rear until the skip or scissors are fully lowered will cause the relief valve located in the control valve to 'blow off' allowing the oil to return to tank. Do not continue to hold the lever rearward when the 'relief valve' blows off, this will cause the hydraulic oil temperature to increase and may cause damage to components. Once the skip is seated on the stops or the scissors are lowered to the rest position release the operating lever to the neutral position.

SERVICE SCHEDULE

IMPORTANT; The Honda HP500H Power Carrier will require additional daily checks, services and adjustments in addition to those listed below, refer to the appropriate section of the HP500H Operators Handbook for details.

Daily or every 10 operating hours check, or carry out the following:-

- Hydraulic oil level & the condition of hoses
- Oil leaks, loose items and fixings
- All levers, controls and cables for correct operation, (binding)
- Lubricate (oil) control lever pivots and linkages as necessary
- Grease the skip pivot and scissor pins
- Lubricate (oil) the skip & scissor ram pivots & scissor pivot pins

First 100 hours of operation:-

Change the hydraulic oil, clean the hydraulic oil filter strainer.

Every 500 hours of operation (more frequently in dusty/dirty conditions)

Change the hydraulic oil, clean the hydraulic oil filter/strainer.
Clean the hydraulic oil filler strainer/breather assembly.

CHECKING HYDRAULIC OIL LEVEL

Note:- the oil level should only be checked when the engine is switched off, the skip is at rest on the stops, the scissors lowered to the rest position and any residual hydraulic pressure remaining in the system has been 'dumped' as described under 'Safe Working'. Wear suitable gloves to protect the skin.

On the rear vertical face of the hydraulic tank there is a small sight glass, the hydraulic oil level is correct when the oil is visible in the centre of the glass. If the oil level is too low, clean the area around the filler/breather on top of the hydraulic tank. Remove the cap and carefully top up the level until it reaches the centre of the glass.

Refer to the Technical Information section of this manual for the correct grade of hydraulic oil.

**CHANGING THE HYDRAULIC OIL AND
CLEANING THE SUCTION STRAINER AND
FILLER STRAINER/BREATHER**

Note:- the oil should only be changed when the engine is switched off, the skip is at rest on the stops, the scissors lowered to the rest position and any residual hydraulic pressure remaining in the system has been 'dumped' as described under 'Safe Working'. Wear suitable gloves to protect the skin.

Run the engine and operate the hydraulics until the hydraulic oil is warm, stop the engine, dump any residual pressure.

Place a suitable container below the hydraulic tank, clean the area around the filler/breather and remove the cap. Carefully undo the drain plug located under the tank, remove and allow the oil to collect in the container.

Replace the drain plug, fitting a new sealing washer if required.

Undo the suction hose connection on the rear vertical face of the tank, remove the hose from the tank and allow any oil to drain into the container.

Remove the four nuts and washers retaining the square cover to the face of the tank, take care not to lose the small sealing washers. Carefully pull the cover away from the tank body taking care not to damage the gasket between the two, pull the cover to the rear until it clears the four studs and continue until the suction strainer located on the back of the cover is clear of the tank.

Allow any oil to drain from the filter, carefully unscrew the strainer and wash out in solvent. Examine the strainer for damage, if punctured it should be replaced, as it will no longer be effective. Refit the strainer in the reverse order replacing the gasket and four small sealing washers if necessary. Take care not to strip the threads on the studs when securing the cover in place. Refit the suction hose.

Remove the three small slotted screws securing the filler/breather body into the top of the tank, carefully lift the assembly clear of the tank taking care not to damage the cork gaskets. Wash the filler

strainer in solvent and examine for damage, as with the suction if punctured it should be replaced as it will no longer be effective. Refit in the reverse order taking care that the three small screws correctly enter the tank and are not cross-threaded.

Wash the cap in solvent and dry off, ensure the vents in the cap are not blocked.

Carefully top up the hydraulic oil until it reaches the centre of the sight glass. Refit the cap.

Start the engine and operate the hydraulic operating lever(s) in both directions a number of times, raising and lowering the skip and scissors to purge the system of air. Bring the skip back onto the stops and lower the scissors to the rest position. Stop the engine, dump any residual pressure remaining in the hydraulic system. Check the level of the oil in the sight glass and top up as necessary. Check the tank for leaks and clean up any spilled oil.

Refer to the Technical Information section of this manual for the correct grade of hydraulic oil.

Dispose of waste oil into designated waste oil storage tanks.

HYDRAULIC CIRCUIT DIAGRAM STANDARD TIPPING MODEL

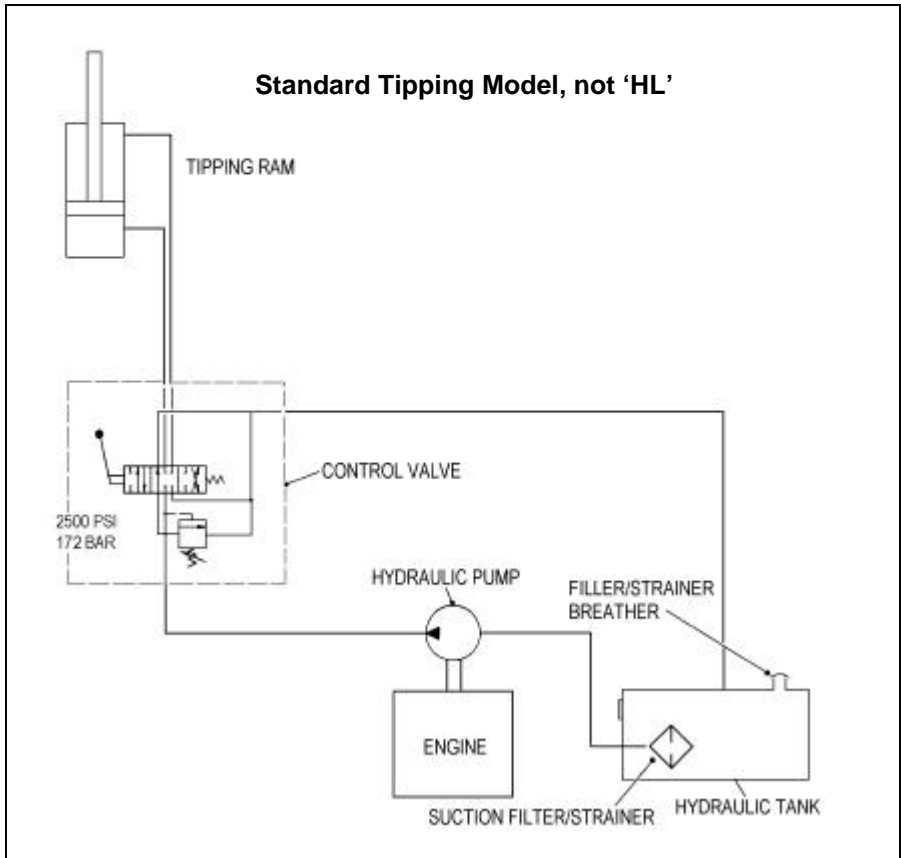

HYDRAULIC CIRCUIT DIAGRAM HL MODEL

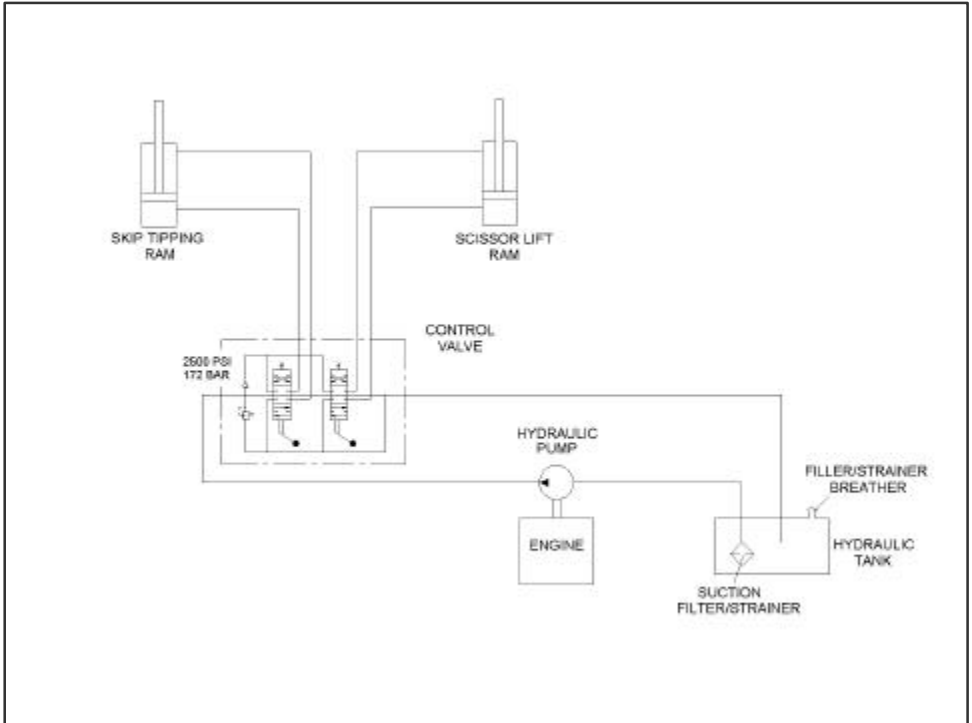

HYDRAULIC CIRCUIT DESCRIPTION

The hydraulic circuit provides power for skip tipping and return and scissor raising and lowering.

The system comprises of the following main components:-

TANK; the tank is filled through a filler/strainer, the cap for which incorporates a breather. In the base of the tank accessed via the end plate is a washable suction strainer.

PUMP; the hydraulic pump is driven directly from the crankshaft of the engine.

FILTER; the suction strainer filter is located in the base of the tank as described above, hydraulic is drawn from the tank through the strainer to the pump.

TIPPING/SCISSOR CONTROL VALVE; the control valve receives oil from the pump and when the outer operating lever is activated delivers oil to the tipping ram, when the inner lever is activated the valve delivers oil to the scissor ram. When the levers are in the neutral position the control valve directs the hydraulic oil back to the tank. The rate of oil flow to the tipping or scissor ram is directly proportional to the distance that the operating lever is moved from the neutral position. The control valve contains a safety device in the form of a preset relief valve. If the operating levers are held fully in either the 'dump' or 'return' or scissor 'raise' or 'lower' position the relief valve will 'blow off' when the ram reaches the end of its travel diverting oil back to the tank. This prevents excessive pressure from damaging the hydraulic pump and other components.

TIPPING RAM; the single tipping ram is of the double acting type, oil enters the lower part of the cylinder (full bore) when the operating lever is moved forwards and pushes the piston and rod out of the cylinder tipping the skip. When the lever is moved to the rear oil enters the upper part of the cylinder (annulus) and pushes the piston and rod into the cylinder lowering the skip. Oil displaced from the opposite part of the cylinder as the piston and rod move in or out is returned to the tank via the control valve.

SCISSOR RAM; the single scissor ram is of the double acting type, oil enters the lower part of the cylinder (full bore) when the operating lever is moved forwards and pushes the piston and rod out of the cylinder raising the scissors. When the lever is moved to the rear oil enters the upper part of the cylinder (annulus) and pushes the piston and rod into the cylinder lowering the scissors. Oil displaced from the opposite part of the cylinder as the piston and rod move in or out is returned to the tank via the control valve.

HYDRAULIC SYSTEM CHECKS

Note; Only qualified experienced personnel should attempt to carry out anything other than the basic checks, unless you have the

equipment and experience checking and adjusting hydraulic pressures should be left to your local distributors service personnel.

If the hydraulic system fails to operate completely or does so extremely slowly, check the following:-

Check that the hydraulic oil tank is full of oil to the correct level.

Check that the coupling between the engine and pump is still transmitting drive and has not broken.

Check that the suction hose between the tank and pump is not damaged or deformed and restricting the flow of oil.

Check that the system for leaks, loose hoses or fittings can allow air to be drawn into the system, causing the pump to cavitate and operate erratically.

Check that the suction strainer has been regularly cleaned in accordance with the maintenance schedule, if not clean the filter.

Check the hydraulic pressure is correct as follows:-

Fit a 0-3000 psi (0-207bar) pressure gauge into the hydraulic system at the base of the tipping ram or scissor ram, or if more accessible, at one of the hose connection to the control valve using a tee-piece and short length of suitable hydraulic hose. Start the engine, move the lever to activate the circuit into which the gauge was fitted and check the reading on the gauge when the ram is fully extended and the relief valve 'blows off', see *Technical Information section for correct pressure*.

If the reading is incorrect, adjust the relief valve setting to correct the pressure.

If the above checks and procedures fail to rectify the fault contact your local distributor.

If on releasing the operating lever to the neutral or hold position you notice that the skip continues to either tip or lower, or the scissors continue to raise or lower please refer the fault to your local distributor, It is possible that a fault has developed in the internal seals of the affected ram or within the control valve itself.

DIMENSIONS, STANDARD MODEL

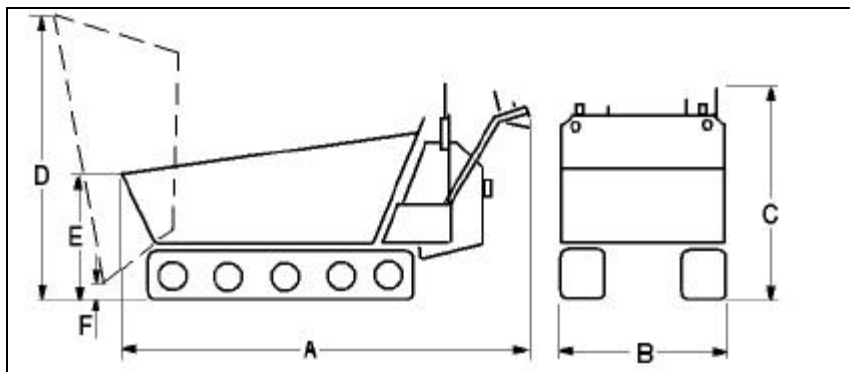

A	Overall length	1.96m
B	Overall width	0.68m
C	Overall height	1.13m
D	Maximum height when skip tipped	1.280m
E	Skip loading height	0.6m
F	Skip discharge height	0.02m

Unladen weight **240kg**

DIMENSIONS, HL MODEL

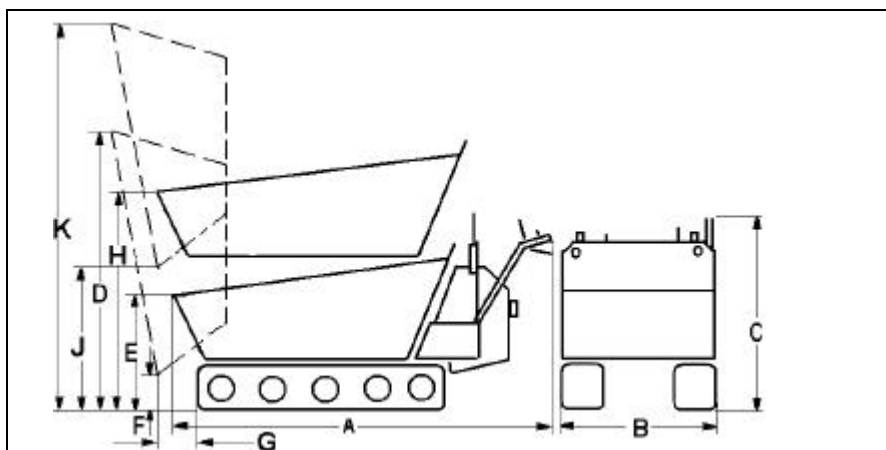

DIMENSIONS, HL MODEL, continued

A Overall length	1.96m
B Overall width	0.68m
C Overall height	1.130m
D Maximum height when skip tipped (scissors lowered)	1.960m
E Skip loading height (scissors lowered)	0.8m
F Skip discharge height (scissors lowered)	0.163m
G Forward discharge distance	0.26m
H Skip loading height (scissors raised)	1.290m
J Skip discharge height (scissors raised)	1.220m
K Maximum height skip raised (scissors raised)	2.460m
Unladen weight	317kg

LUBRICANTS & CAPACITIES (Total-Fina factory fill)

Hydraulic Oil	Azzola ZS46	Capacity 5 litres
Grease	Multis EP2	
General lubricating oil (pivot pins)	Rubia B20W/30	

PRESSURES

Hydraulic Pressure	2500psi (172)bar
---------------------------	-------------------------

MAXIMUM PAYLOAD CAPACITY

On level ground	500kgs
On gradients	350kgs

MAXIMUM GRADIENT

Maximum Downward gradient	15°
Maximum Upward gradient	20°

NOISE LEVELS

Operators Ear	85LPA
Directive 2000/14/EC	101LWA

TRAVEL SPEED

Forward travel	0-4.3 km/h
Reverse travel	0-3.6 km/h

VIBRATION AT HANDLEBARS

Hand/Arm Vibration (EN1033)	11 m/s²@3600 rpm
------------------------------------	------------------------------------

TD500 TD500HL

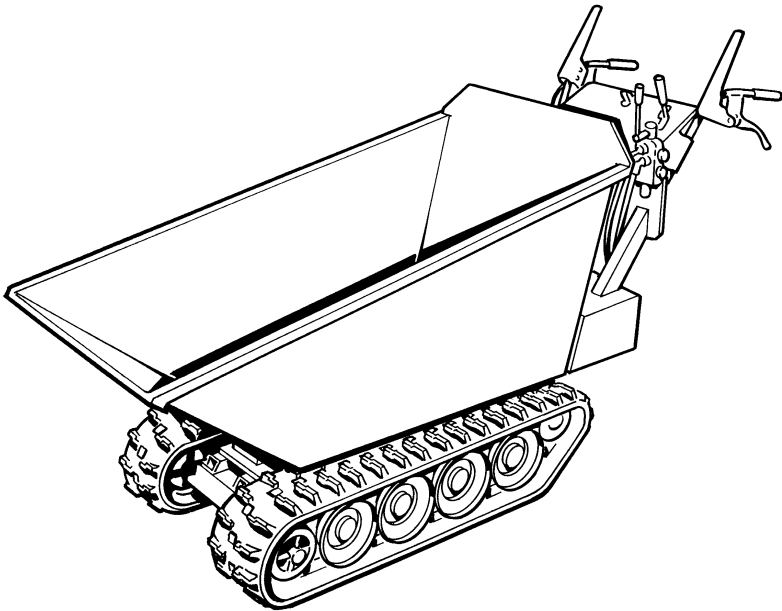

PARTS SECTION

TD500

Parts

SKIP & CHASSIS	1 - A - 1
HANDLEBAR SUPPORT RH	1 - A - 1A
HYDRAULIC CIRCUIT	2 - A - 1
RAM TIPPING	2 - A - 2
TANK & CONTROL VALVE	3 - A - 1
PUMP & COUPLING	4 - A - 1
DECALS	5 - A - 1

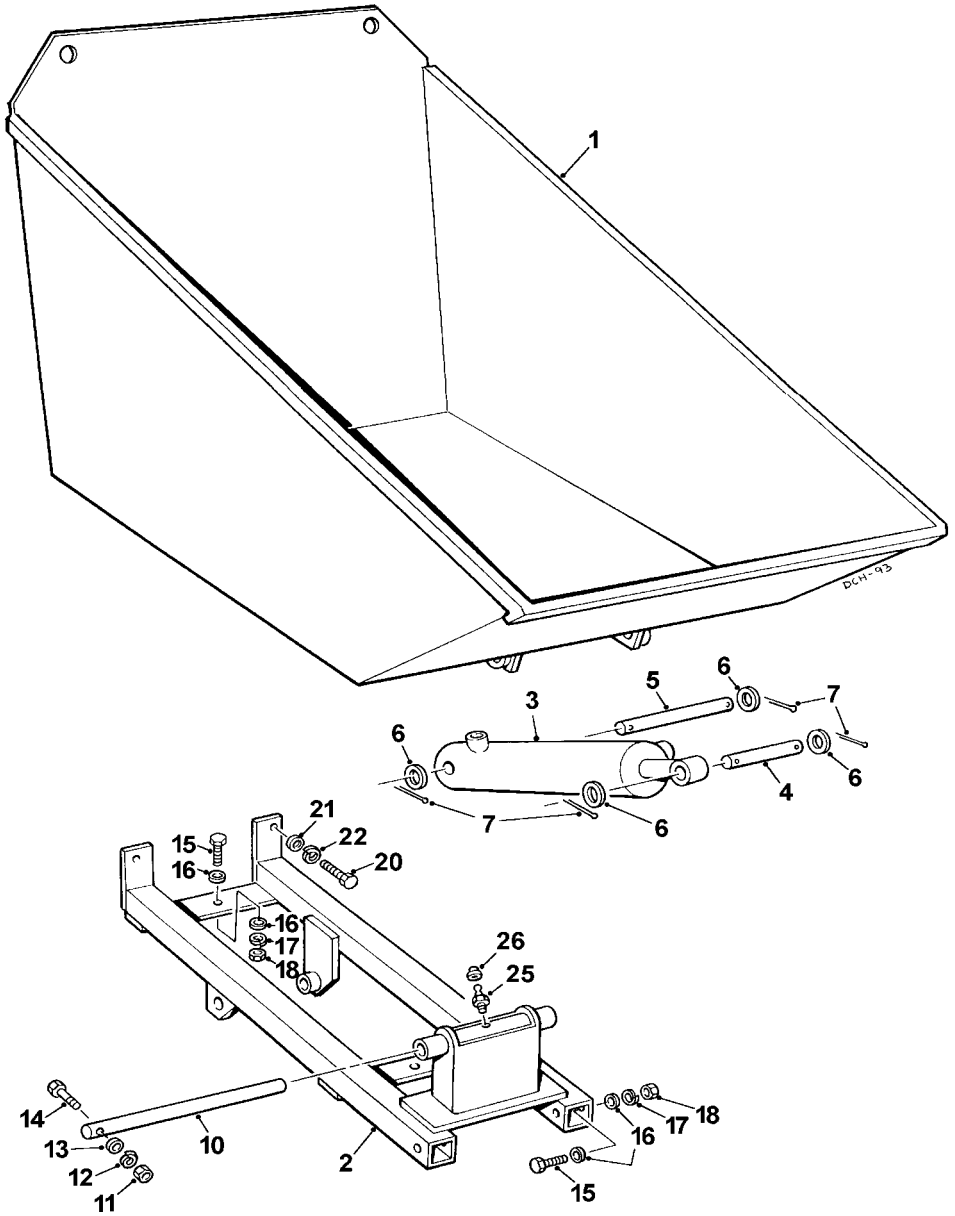

SKIP & CHASSIS**1 - A - 1**

Item	Part no	Serial no	Description	Qty
1	V2005333		SKIP	2
2	V2005320		CHASSIS, subframe	2
3	V2005330		RAM, skip tipping	2
4	V2005341		PIN, ram rod	1
5	V2005342		PIN, ram body	1
6	267S09		WASHER, flat	4
7	44S16J		PIN, split	4
10	V2005340		PIN, skip pivot	1
11	7S02		NUT	1
12	17S03		WASHER, spring	1
13	267S04		WASHER, flat	1
14	8S02D		BOLT	1
15	11S04D		SCREW, set	4
16	267S06		WASHER, flat	8
17	17S05		WASHER, spring	4
18	7S04		NUT	4
20	11S03C		SCREW, set	2
21	267S05		WASHER, flat	2
22	17S04		WASHER, spring	2
25	131S04		NIPPLE, grease	1
26	176S01		CAP, grease nipple	1

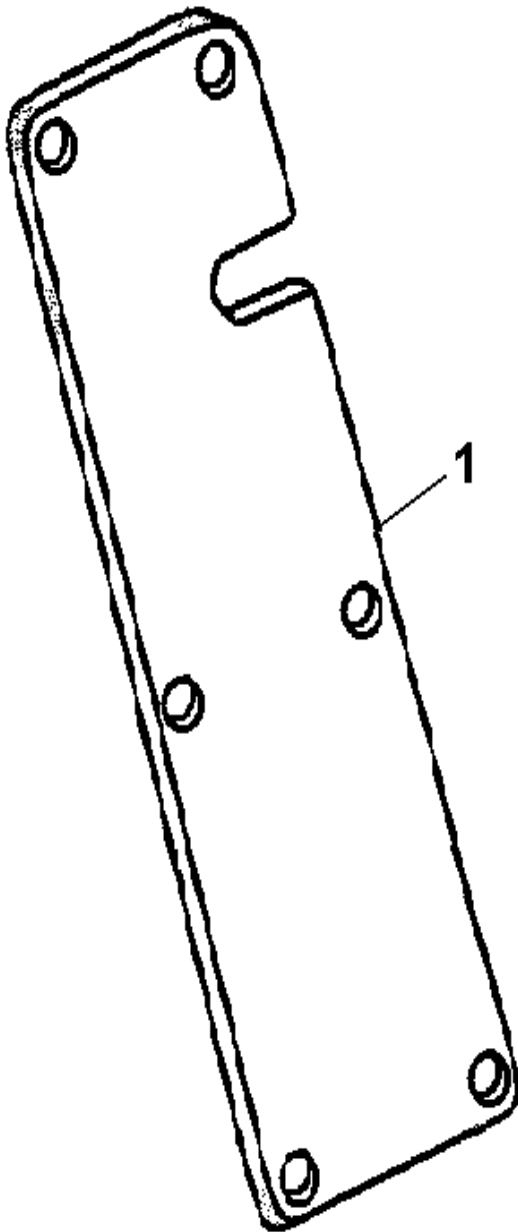

HANDLEBAR SUPPORT RH**1 - A - 1A**

Item	Part no	Serial no	Description	Qty
1	V2005765	/mid '07 Onwards	SUPPORT, Handlebar R/H	1
2	153S01		"U" CLAMP 29mm	2
3	153S02		"U" CLAMP 32mm	1
4	267S05		WASHER, Flat	6
5	17S04		WASHER, Spring	6

HYDRAULIC CIRCUIT

2 - A - 1

Item	Part no	Serial no	Description	Qty
1	32S02J		HOSE, pump to control valve	1
2	32S02J		HOSE, suction, tank to pump	1
3	34S01N		HOSE, control valve to ram lift	1
4	53S01J		HOSE, control valve to ram lower	1
5	36S02UU		HOSE, control valve return to tank	1
6	122S03		ADAPTOR, male/male	4
6A	119S03		ADAPTOR, male/male	1
7	100S03		SEAL, bonded	6
7A	100S02		SEAL, bonded	1
8	119S03		ADAPTOR, male/male	2
9		PLUG, blanking	2
10	122S02		ADAPTOR, male/male	2
11	100S02		SEAL, bonded	2
12	154S01		ADAPTOR, tee	1
13	120S01		CAP, blanking	1
15	V2005330		RAM, skip tipping, (<i>see page 2-A-2</i>)	1
16	V603013		BUSH	4
19		PUMP, hydraulic (<i>see page 4-A-1</i>)	1
20		TANK (<i>see page 3-A-1</i>)	1
21	V2003111		STRAP, nylon	AR

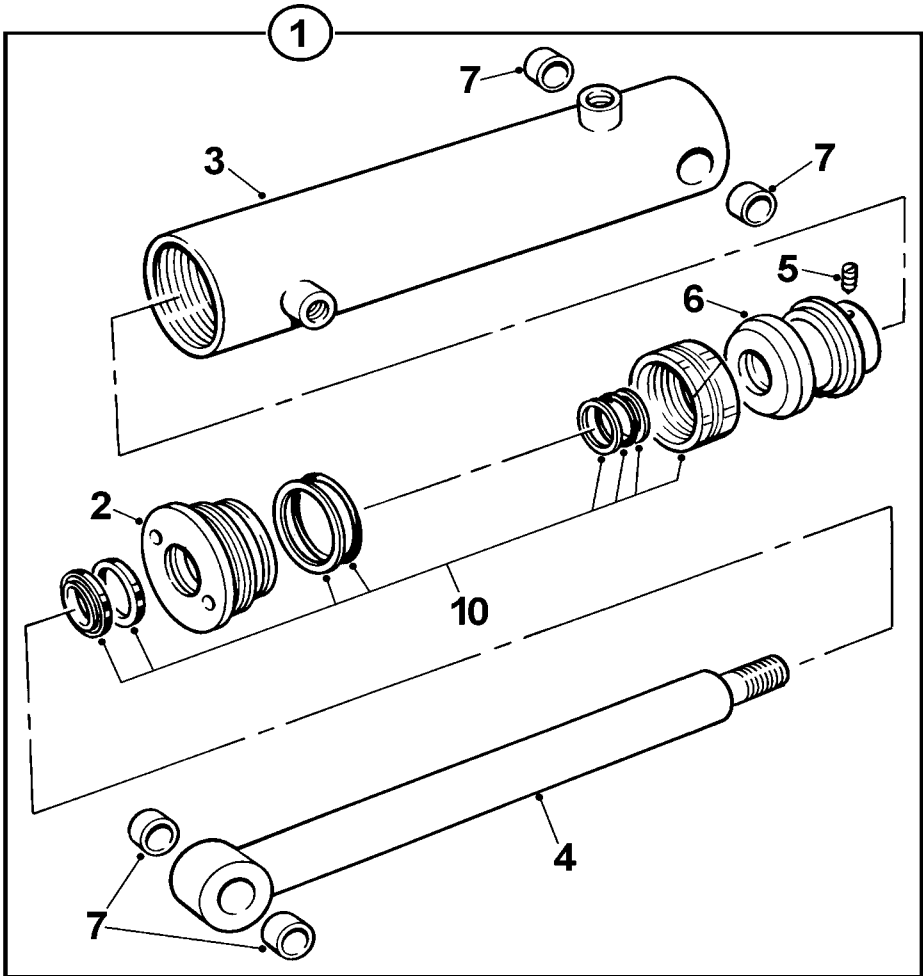

RAM, skip tipping**2 - A - 2**

Item	Part no	Serial no	Description	Qty
1	V2005330		RAM, skip tipping assembly	1
2	V603576		GLAND, cylinder	1
3	V603577		CYLINDER, ram	1
4	V603578		ROD, piston	1
5	V603578		SCREW, grub	1
6	V603580		PISTON	1
7	V603013		BUSH	4
10	V603574		KIT, seals	1

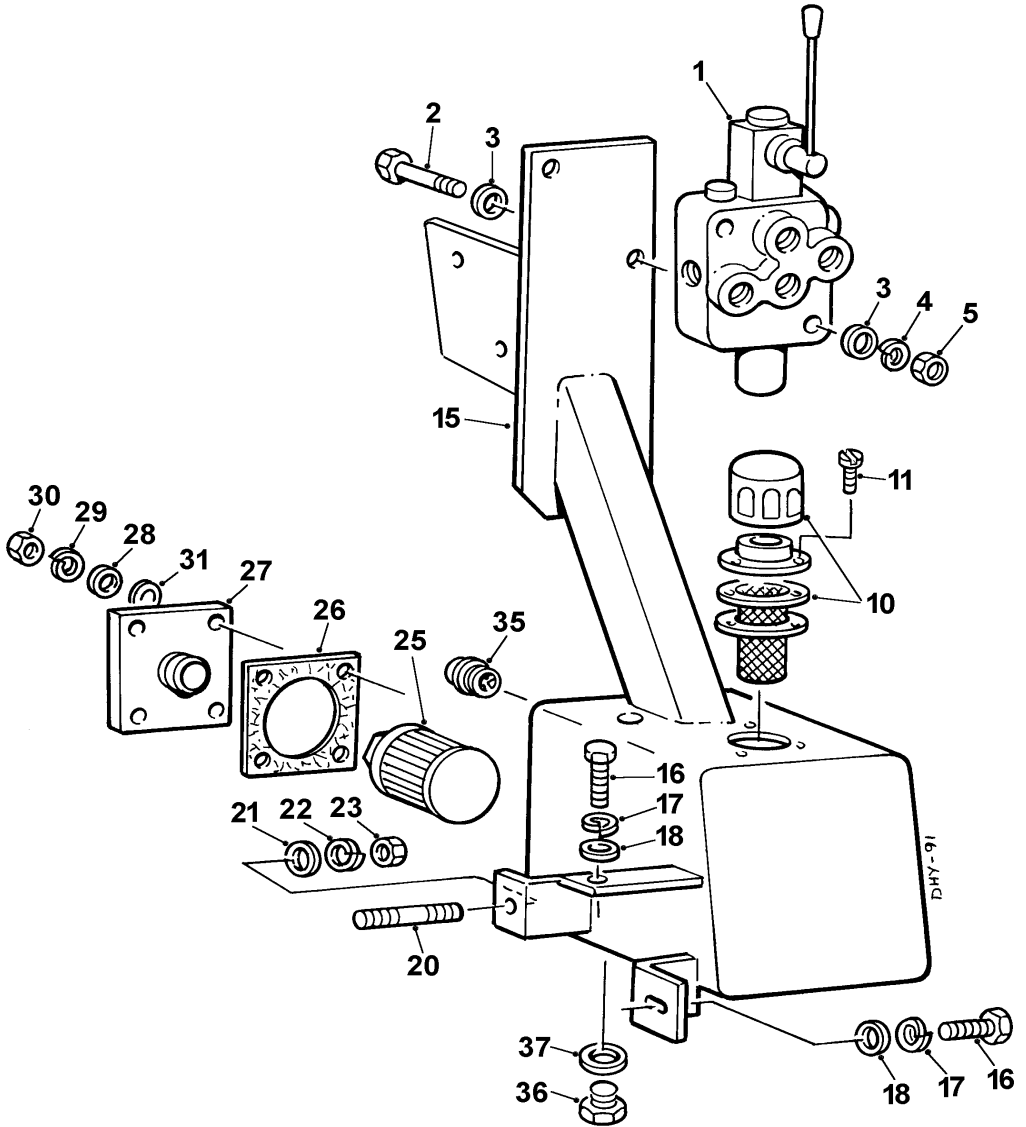

TANK & CONTROL VALVE

3 - A - 1

Item	Part no	Serial no	Description	Qty
1	V2005357	1647/	VALVE, tip control, N.L.A. use item 1A	1
.....	V603581		KIT, seals	1
.....	V603582		VALVE, relief	1
.....	V603583		HANDLE BODY	1
.....	V603573		HANDLE, c/w nut & knob	1
.....	V603684		END CAP & SPRING KIT, 2 bolt	1
V2005357 control valve is now obsolete, if a new valve assembly is required use item 1A				
1A	V2005764	/1648	VALVE, tip control,	1
.....	V603675		KIT, seals	1
.....	V603676		VALVE, relief	1
.....	V603677		HANDLE BODY	1
.....	V603678		HANDLE, c/w nut & knob	1
.....	V603685		END CAP & SPRING KIT, 4 bolt	1
2	8S03H		BOLT	2
3	267S05		WASHER, flat	4
4	17S04		WASHER, spring	2
5	7S03		NUT	2
10	V2005359		FILLER/BREATHER	1
11	68S02A		SCREW, slotted head	3
15	V2005347		TANK, hydraulic	1
15A	153S01		Clamp, "U" Bolt (not illustrated)	1
16	11S03C		SCREW, set	2
17	17S04		WASHER, spring	2
18	267S05		WASHER, flat	2
20	411411135		STUD	1
21	267S06		WASHER, flat	1
22	17S05		WASHER, spring	1
23	324S04		NUT	1
25	V2005355		FILTER, suction	1
26	V2005356		GASKET, filter mounting plate	1
27	V2005360		PLATE, filter mounting	1
28	267S04		WASHER, flat	4
29	17S03		WASHER, spring	4
30	7S02		NUT	4
31	186S02		WASHER, nylon	4
35	V2005269		INDICATOR, oil level	1
36	127S04		PLUG, drain	1
37	100S04		SEAL, bonded	1

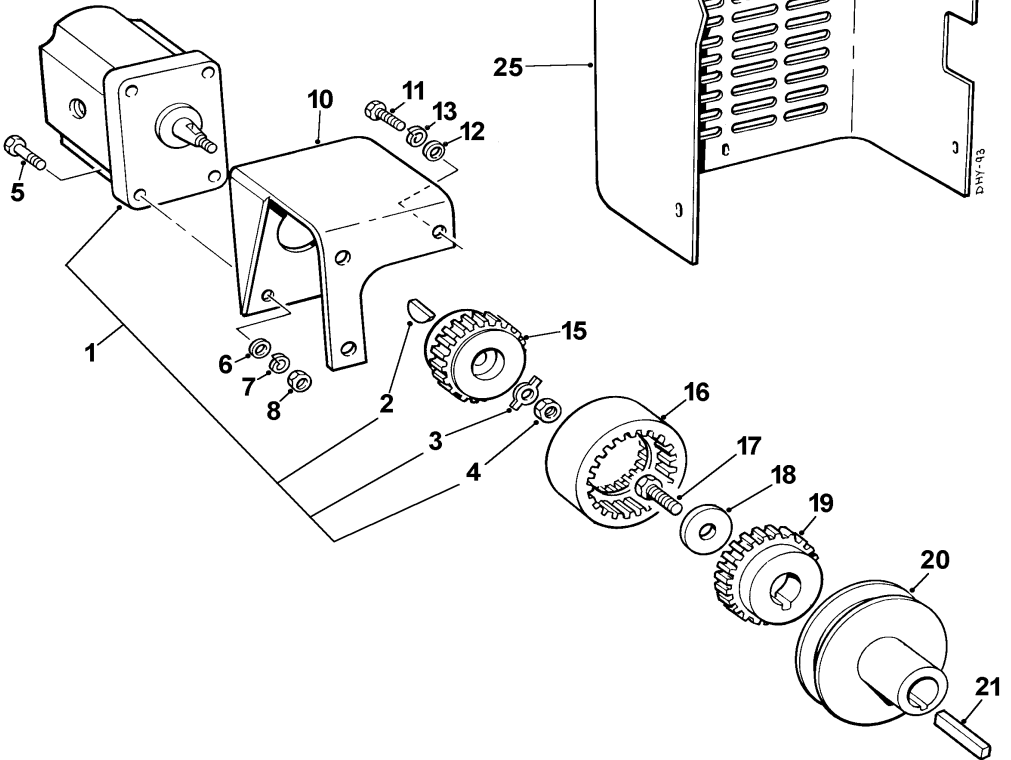
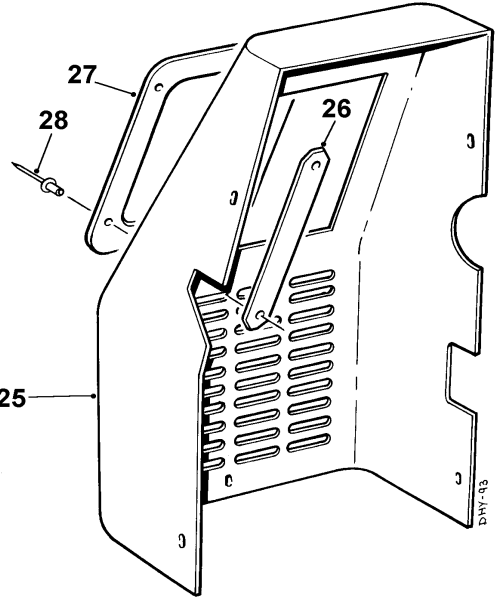
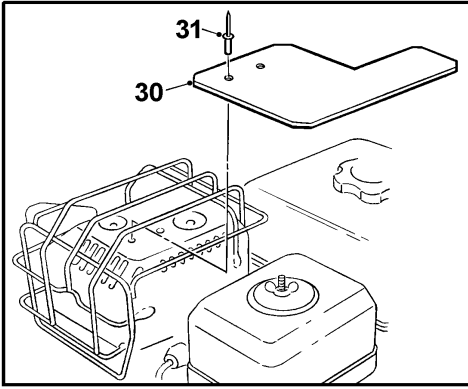

DHY-93

Item	Part no	Serial no	Description	Qty
1	V2005363	1588/	PUMP, hydraulic, assembly "Rocquet"	1
.....	V603575		KIT, repair, c/w seals "Rocquet"	A/R
1	V2005363	/1589	PUMP, hydraulic, assembly "Albroco"	1
.....	V603669		KIT, repair, c/w seals "Albroco"	A/R
2		KEY, (part of repair kit)	1
3		WASHER, tab (part of repair kit)	1
4		NUT (part of repair kit)	1
When ordering Hyd Pump Repair Kits state pump manufacturer				
5	8S02B		BOLT, "Rocquet" pumps	4
5	8S02C		BOLT, "Albroco" pumps	4
6	267S04		WASHER, flat	4
7	17S03		WASHER, spring	4
8	7S02		NUT	4
10	V2005358		BRACKET, pump mounting	1
11	11S03B		SCREW, set	3
12	267S05		WASHER, flat	3
13	17S04		WASHER, spring	3
*15	V2005346	1593/	COUPLING, pump 55mm dia UCC/Parker	1
*15	V603659	/1594	COUPLING, pump 53mm dia KTR	1
*16	147320303	1593/	SLEEVE, coupling, UCC/Parker	1
*16	V603660	/1594	SLEEVE, coupling, KTR	1
17		SCREW (see engine parts catalogue)	1
18		WASHER (see engine parts catalogue)	1
*19	V2005345	1593/	COUPLING, engine 55mm dia UCC/Parker	1
*19	V603661	/1594	COUPLING, engine 53mm dia KTR	1
20	V2005344		PULLEY	1
21	305110550		KEY, parallel	1
* see note below				
25	V2005365		GUARD, belt drive	1
26	V2005367		PLATE	1
27	V2005366		FLANGE, guard	1
28	101S05B		RIVET	4
30	V2005589		GUARD, engine	1
31	101S05D		RIVET	2

Note:- Up to Serial numbers 1593 UCC/Parker Pump-Engine Couplings and Sleeve assemblies where fitted. From Serial numbers 1594 KTR Pump-Engine Couplings and Sleeve assemblies replaced the UCC/Parker components. The individual component items from the two manufacturers are not interchangeable but the complete assemblies are. If a replacement UCC/Parker engine or pump coupling is required, either part number V2005345 or V2005346, order a complete replacement KTR Coupling Assembly under part no V2005762. The UCC/Parker Sleeve, part no 147320303 is still available and can be ordered separately if required for machines with UCC/Parker couplings.

1 **WINGET**



4 **TD 500**

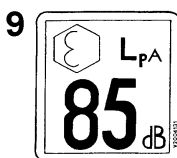
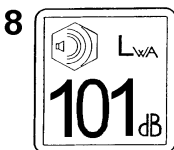
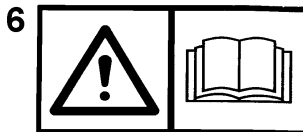
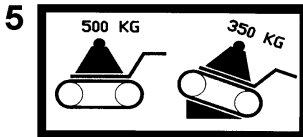

11 **TAKE EXTRA CARE WHEN TIPPING
NON FREE RUNNING LOADS**

12 **SAFETY WARNING**

- 1 Before starting this machine, the operator should be familiar with the operating instructions issued by the manufacturer.
- 2 The manufacturer's rated capacity must never be exceeded.
- 3 Before carrying out any maintenance, servicing, or greasing, always ensure that the engine has been switched off. Never work on a machine while it is running.

W504694600

13 **WARNING
DO NOT WORK UNDER
UNPROPPED SKIP**

14 **WINGET** WINGET LIMITED
P.O. Box 88, Smallhurst Lane, Bolton, Lancs BL6 0WW
Tel: (0204) 655195 Fax: (0204) 655205

Model			
Serial No.			
Engine No.			
Capacity	Mass (kg)		
SRO No.	Power (kW)		
Year Of Manuf.	Eng. (rpm)	Drum (rpm)	

A Seddon Group Company

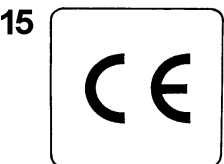

17 **JOHNSON CONSTRUCTION MACHINERY**
MANUFACTURED BY: SEDDONS (PLANT & ENGINEERS) LTD
P.O. BOX 41, BOLTON, LANCOS
Telephone: 01204 63123 Fax: 01204 658472

MODEL	SERIAL No.	
ENGINE	ENGINE No.	
ENGINE POWER	ENGINE R.P.M.	
	MACHINE WEIGHT (KG)	
	YEAR OF MANUFACTURE	

DECALS**5 - A - 1**

Item	Part no	Serial no	Description	Qty
1	V2004636		DECAL, "WINGET", 150mm long	2
2	JPP1201		DECAL, "JOHNSON"	2
3	V2004744		DECAL, eye protection	1
4	V2005368		DECAL, "TD500"	2
5	V2005369		DECAL, load capacity TD500	1
6	V2004229		DECAL, read operator's handbook	1
7	V2003100		DECAL, hydraulic oil	1
8	V2005311		DECAL, noise LWA 101	1
9	V2004131		DECAL, noise 85 LPA	1
10	10284A01		DECAL, dump/return	1
11	10536A02		DECAL, tipping non free running loads	1
12	504694600		DECAL, safety warning	1
13	DM157		DECAL, do not work under skip	1
14	V2003037		PLATE, serial number, Winget	1
.....	101S05D		RIVET, for serial number plate	4
15	V2004223		DECAL, "CE" mark	1
16	V2004281		DECAL, chain drive	1
17	JDD8089		PLATE, serial number, Johnson	1
.....	101S05D		RIVET, for serial number plate	2

TD500HL

Parts

SKIP & MOUNTING FRAME	1 - A - 1
HANDLEBAR SUPPORT RH	1 - A - 1A
SCISSOR & CHASSIS	1 - A - 2
HYDRAULIC CIRCUIT	2 - A - 1
CONTROL VALVE	2 - B - 1
TANK, hydraulic	2 - C - 1
RAMS, scissors lift & skip tipping	2 - R - 1
PUMP & COUPLING	3 - A - 1
DECALS	4 - A - 1

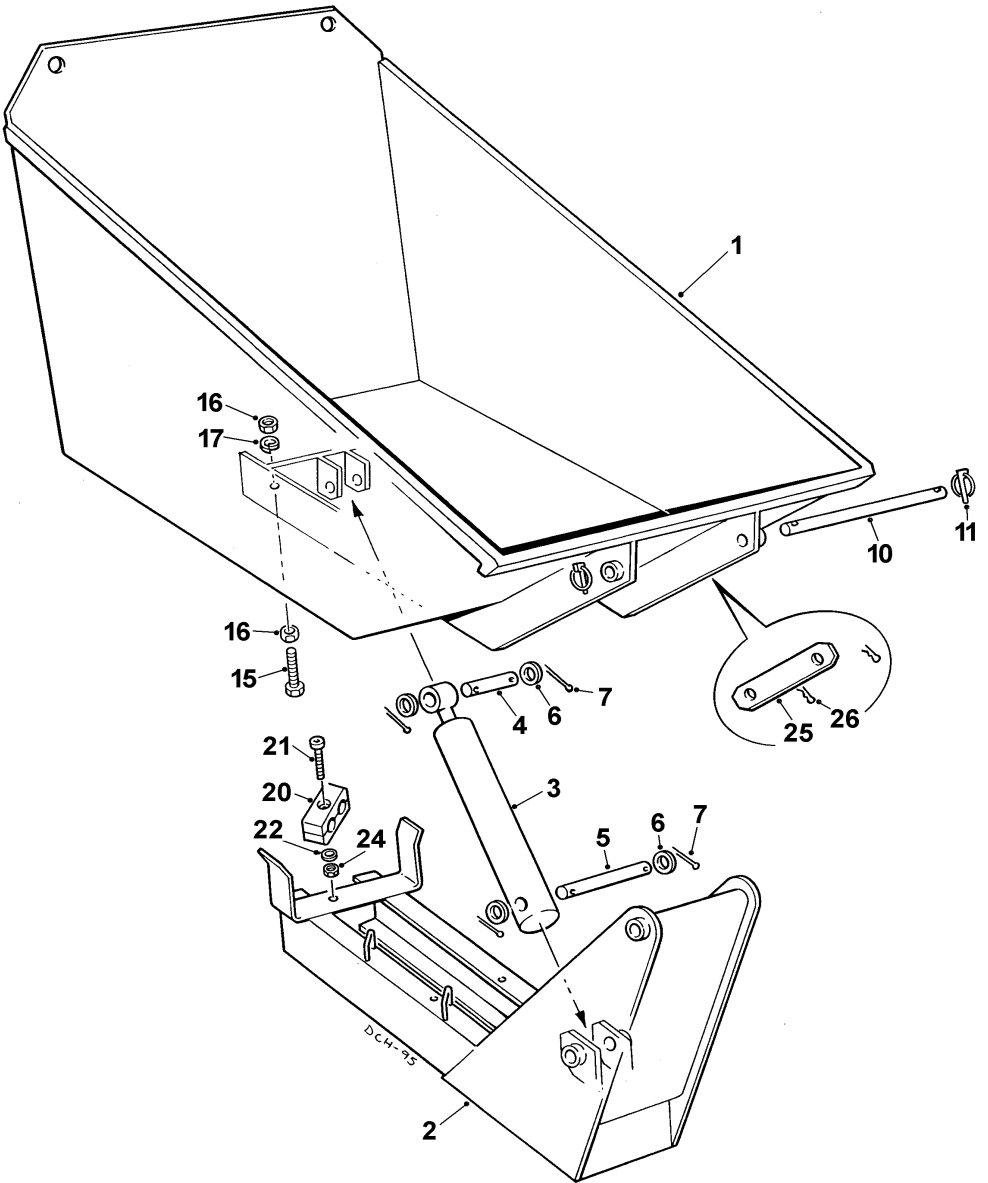

SKIP & MOUNTING FRAME**1 - A - 1**

Item	Part no	Serial no	Description	Qty
1	V2005429		SKIP	1
2	V2005410		FRAME, skip mounting	1
3	V2005397		RAM, skip tipping (<i>see page 2-R-1</i>)	2
4	V2005341		PIN, ram rod	1
5	V2005342		PIN, ram body	1
6	267S09		WASHER, flat	4
7	44S16J		PIN, split	4
10	V2005423		PIN, skip pivot	1
11	V2005403		PIN, lynch	2
15	11S05K		SCREW, set	2
16	7S05		NUT	4
17	17S06		WASHER, spring	2
20	187S08EE		CLAMP, hose	1
21	68S04F		SCREW, cap head	1
22	267S05		WASHER, flat	1
24	61S03		NUT, "Binx", self locking	1
25	SB1321		SUPPORT, skip	1
26	V601147		PIN, feather 'R' clip	2

1 - A - 1A

TD500HL Dumper

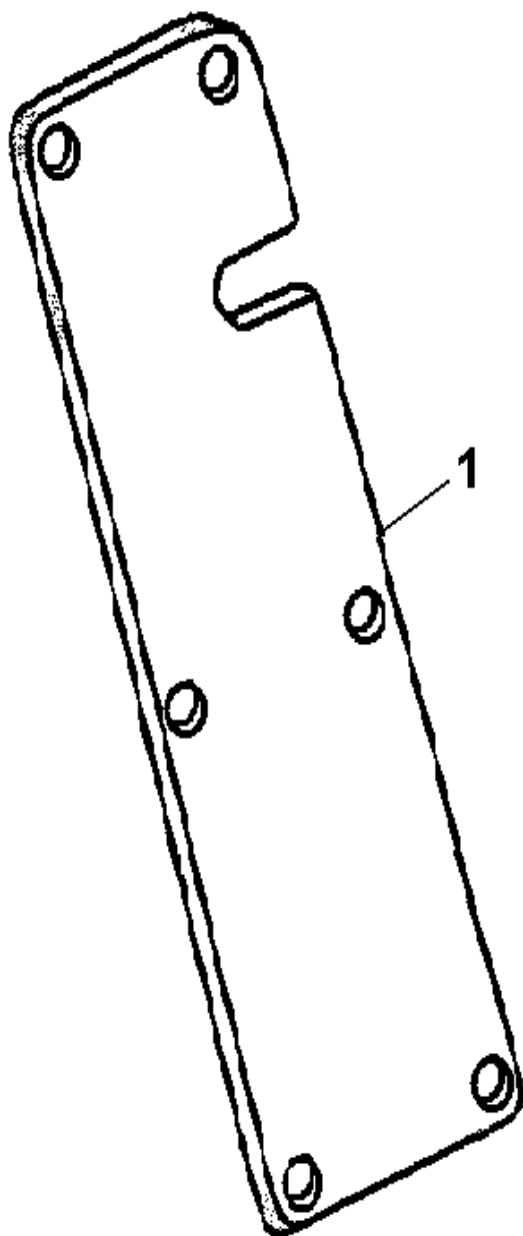

HANDLEBAR SUPPORT RH**1 - A - 1A**

Item	Part no	Serial no	Description	Qty
1	V2005765	/mid '07 Onwards	SUPPORT, Handlebar R/H	1
2	153S01		"U" CLAMP 29mm	2
3	153S02		"U" CLAMP 32mm	1
4	267S05		WASHER, Flat	6
5	17S04		WASHER, Spring	6

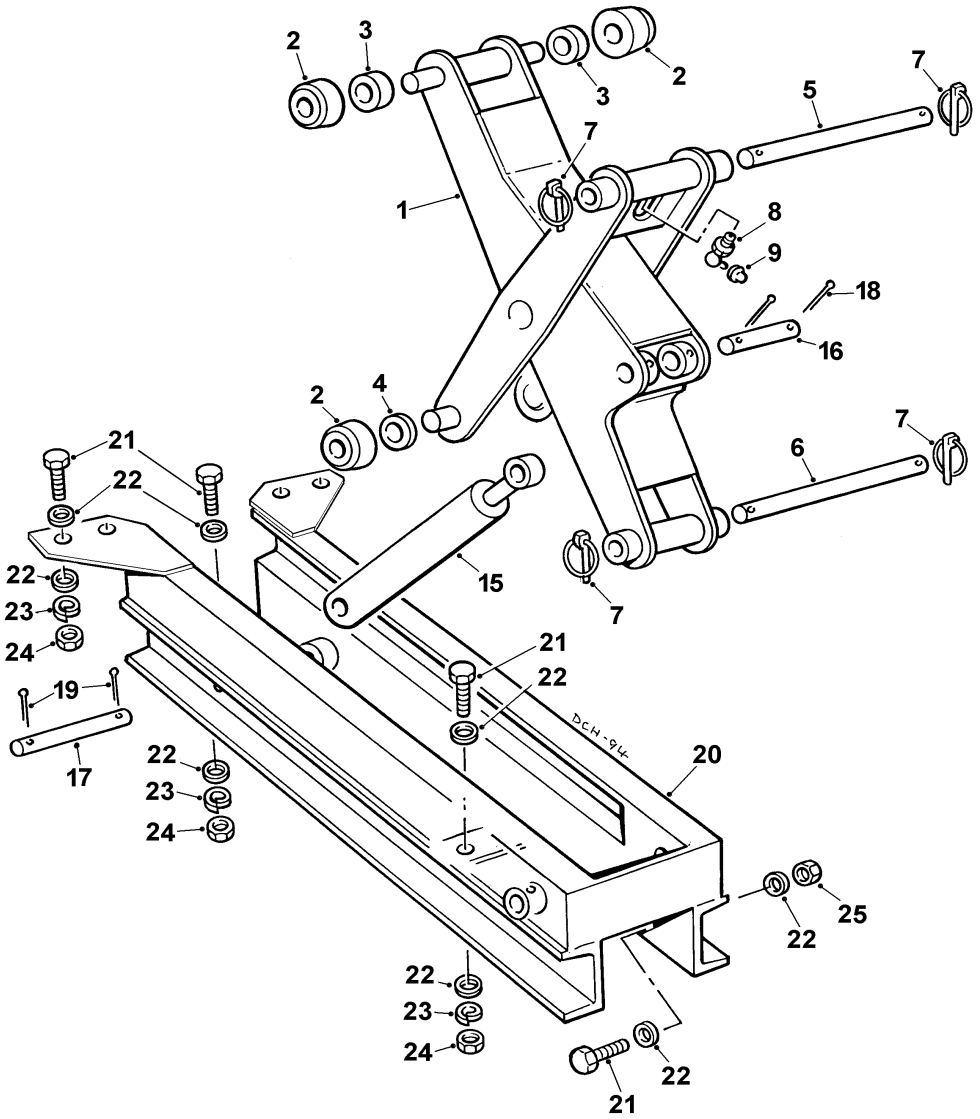

SCISSOR & CHASSIS**1 - A - 2**

Item	Part no	Serial no	Description	Qty
1	V2005436		SCISSOR, welded assembly	1
2	V2005415		ROLLER	4
3	V2005417		SPACER, upper	2
4	V2005416		SPACER, lower	2
5	V2005424		PIN, scissor upper pivot	1
6	V2005424		PIN, scissor lower pivot	1
7	V2005403		PIN, lynch	4
8	131S02		NIPPLE, grease	1
9	176S01		CAP, grease nipple	1
15	V2005330		RAM, scissor lift (see page 2-R-1)	2
16	V2005408		PIN, ram eye	1
17	V2005401		PIN, ram cylinder	1
18	44S03F		PIN, split	2
19	44S16J		PIN, split	2
19A	267S07		WASHER, flat	2
20	V2005392		CHASSIS, subframe	1
21	11S04D		SCREW, set	8
22	267S06		WASHER, flat	16
23	17S05		WASHER, spring	8
24	7S04		NUT	6
25	59S03		NUT, "Nyloc", self locking	2

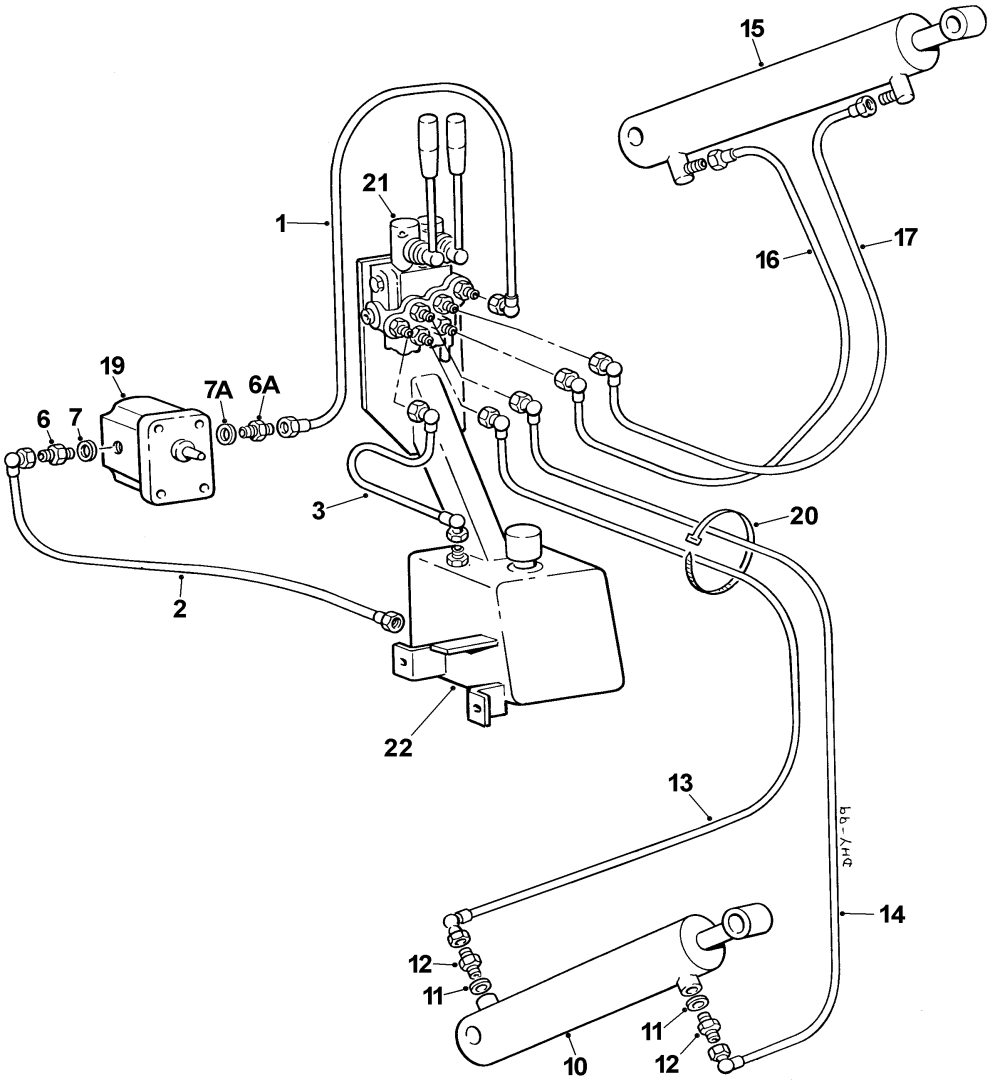

Item	Part no	Serial no	Description	Qty
1	32S02J		HOSE, pump to control valve	1
2	32S02J		HOSE, suction, tank to pump	1
3	36S02UU		HOSE, control valve return to tank	1
6	122S03		ADAPTOR, male/male	1
6A	119S03		ADAPTOR, male/male	1
7	100S03		SEAL, bonded	1
7A	100S02		SEAL, bonded	1
10	V2005330		RAM, scissor lift (<i>see page 2-R-1</i>)	1
11	100S02		SEAL, bonded	2
12	122S02		ADAPTOR, male/male	2
13	319S01D		HOSE, control valve to scissor lift	1
14	53S01J		HOSE, control valve to scissor lower	1
15	V2005397		RAM, skip tipping (<i>see page 2-R-1</i>)	1
16	318S01D		HOSE, control valve to skip tip	1
17	318S01M		HOSE, control valve to skip lower	1
19		PUMP, hydraulic (<i>see page 3-A-1</i>)	1
20	V2003253		STRAP, nylon	AR
21		VALVE, control (<i>see page 2-B-1</i>)	1
22		TANK (<i>see page 2-C-1</i>)	1

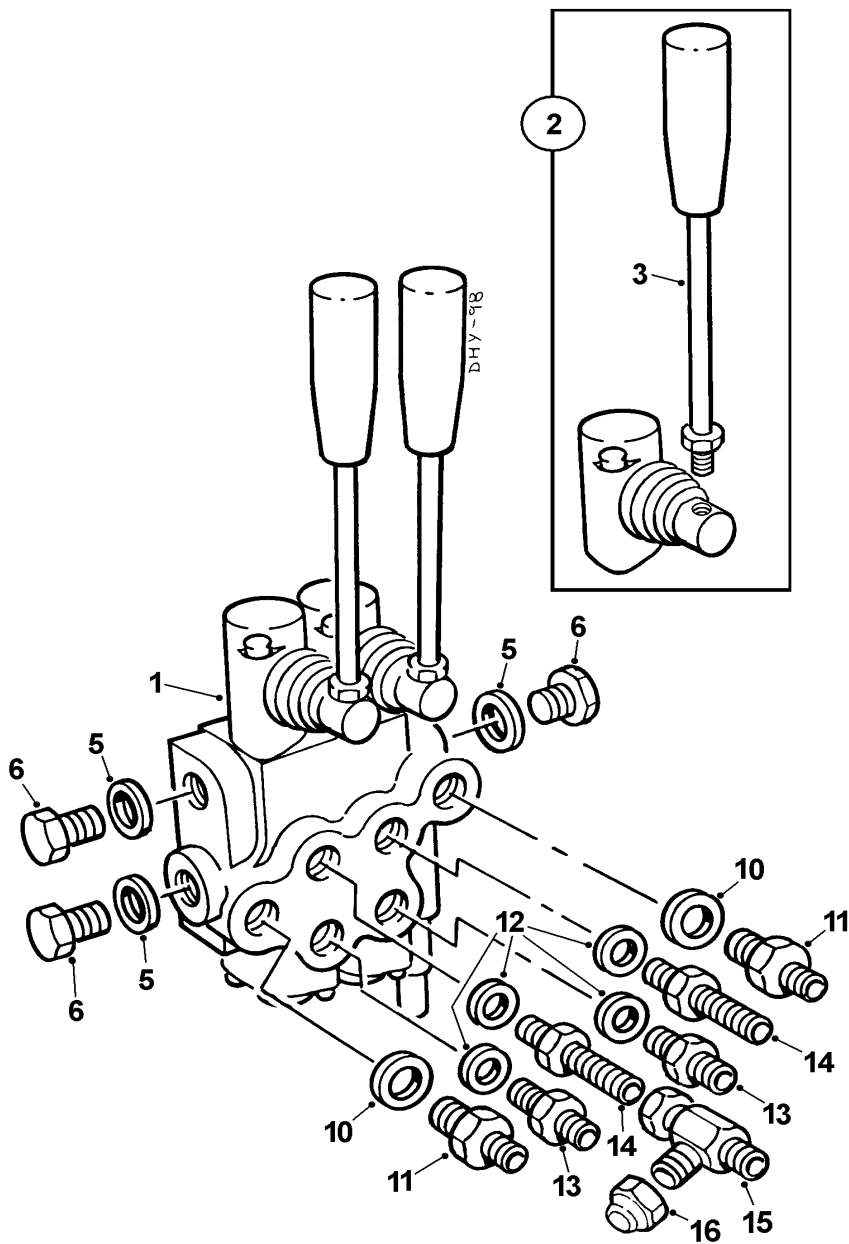

CONTROL VALVE**2 - B - 1**

Item	Part no	Serial no	Description	Qty
1	SB1015		VALVE, control, assembly	1
2	V603594		LEVER HOUSING, c/w lever	1
3	V603573		LEVER	1
.....	V603592		KIT, seals	1
.....	V603593		VALVE, relief	1
5	100S04		SEAL, bonded	3
6	127S04		PLUG, hex head	3
10	100S04		SEAL, bonded	2
11	119S08		ADAPTOR, male/male	2
12	100S03		SEAL, bonded	4
13	119S03		ADAPTOR, male/male	2
14	93S08		ADAPTOR, bulkhead	2
15	154S01		ADAPTOR, tee	1
16	120S01		CAP, blanking	1

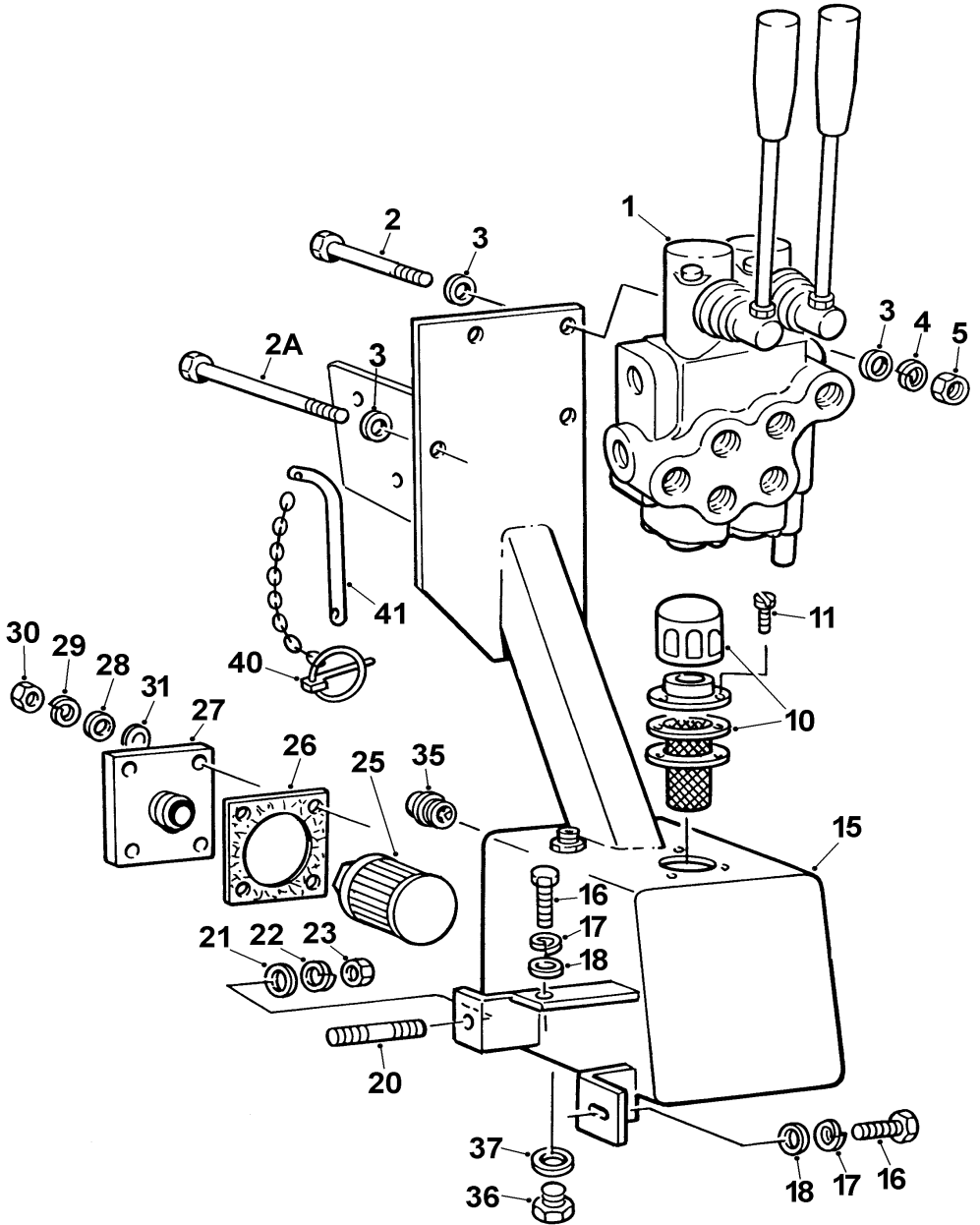

Item	Part no	Serial no	Description	Qty
1	SB1015		VALVE, control, (see page 2-B-1)	1
2	8S03F		BOLT, 50mm long	1
2A	8S03H		BOLT, 60mm long	1
3	267S05		WASHER, flat	4
4	17S04		WASHER, spring	2
5	7S03		NUT	2
10	V2005359		FILLER/BREATHER	1
11	68S02A		SCREW, slotted head	3
15	V2005347		TANK, hydraulic	1
15A	153S01		CLAMP "U" Bolt (not illustrated)	1
16	11S03C		SCREW, set	2
17	17S04		WASHER, spring	2
18	267S05		WASHER, flat	2
20	411411135		STUD	1
21	267S06		WASHER, flat	1
22	17S05		WASHER, spring	1
23	324S04		NUT	1
25	V2005355		FILTER, suction	1
26	V2005356		GASKET, filter mounting plate	1
27	V2005360		PLATE, filter mounting	1
28	267S04		WASHER, flat	4
29	17S03		WASHER, spring	4
30	7S02		NUT	4
31	186S02		WASHER, nylon	4
35	V2005269		INDICATOR, oil level	1
36	127S04		PLUG, drain	1
37	100S04		SEAL, bonded	1
40	902S02		PIN, lynch c/w chain	1
41	V2004217		PIN, scissor safety lock	1

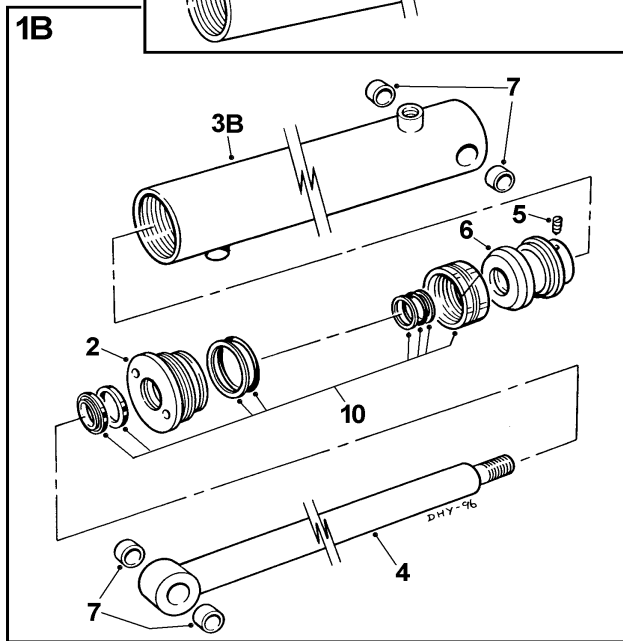
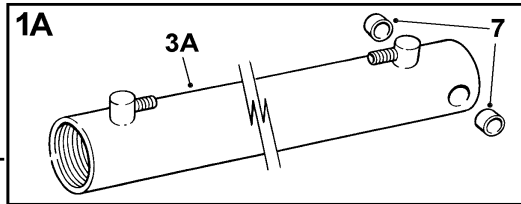
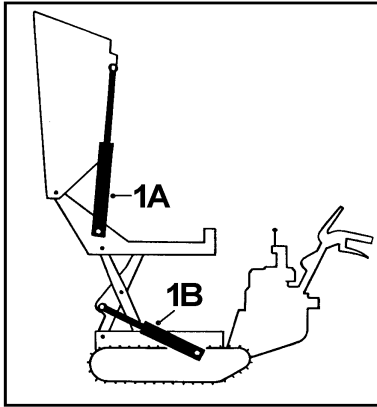

Item	Part no	Serial no	Description	Qty
1A	V2005397		RAM, skip tipping, assembly	1
1B	V2005330		RAM, scissors lift, assembly	1
2	V603576		GLAND, cylinder	1
3A	V2005526		CYLINDER, skip tipping ram	1
3B	V603577		CYLINDER, scissors lift ram	1
4	V2005525		ROD, piston, skip tipping ram	1
4	V603578		ROD, piston, scissors lift ram	1
5	V603579		SCREW, grub	1
6	V603580		PISTON	1
7	V603013		BUSH	4
10	V603574		KIT, seals	1

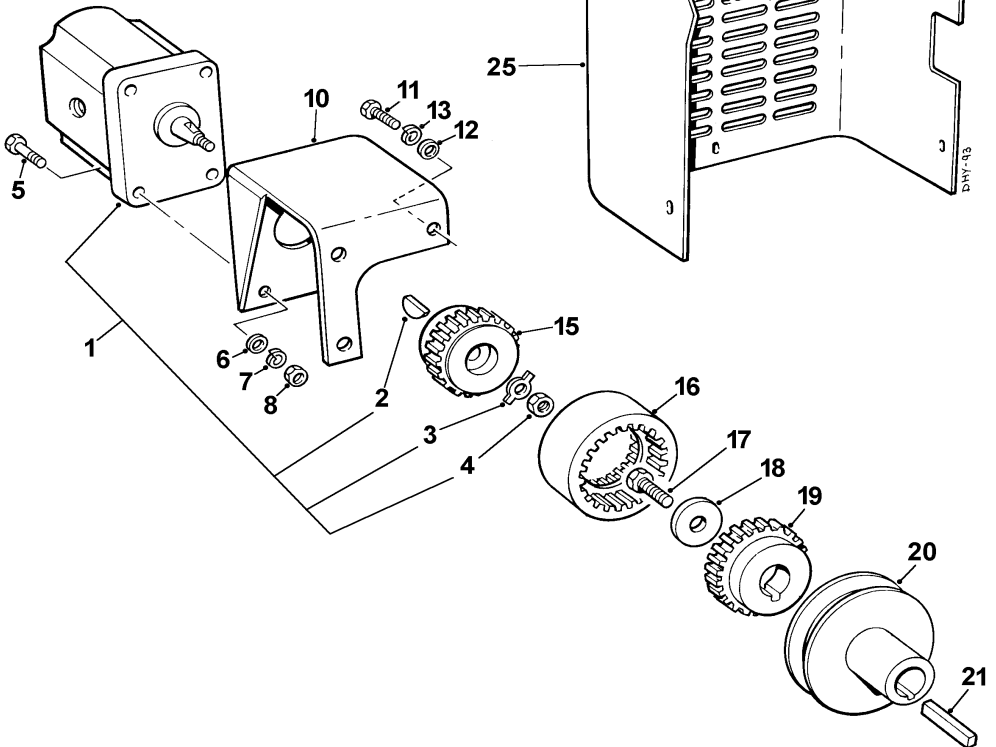
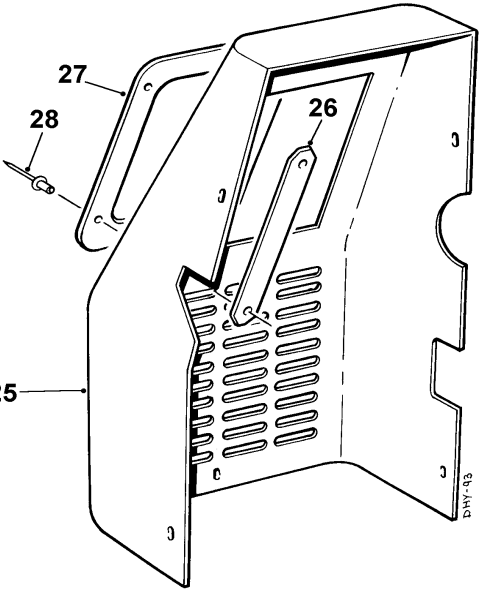
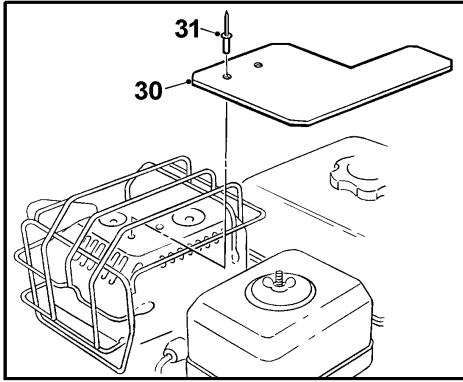

Item	Part no	Serial no	Description	Qty
1	V2005363	1588/	PUMP, hydraulic, assembly "Rocquet"	1
.....	V603575		KIT, repair, c/w seals "Rocquet"	A/R
1	V2005363	/1589	PUMP, hydraulic, assembly "Albroco"	1
.....	V603669		KIT, repair, c/w seals "Albroco"	A/R
2		KEY, (part of repair kit)	1
3		WASHER, tab (part of repair kit)	1
4		NUT (part of repair kit)	1
When ordering Hyd Pump Repair Kits state pump manufacturer				
5	8S02B		BOLT, "Rocquet" pumps	4
5	8S02C		BOLT, "Albroco" pumps	4
6	267S04		WASHER, flat	4
7	17S03		WASHER, spring	4
8	7S02		NUT	4
10	V2005358		BRACKET, pump mounting	1
11	11S03B		SCREW, set	3
12	267S05		WASHER, flat	3
13	17S04		WASHER, spring	3
*15	V2005346	1593/	COUPLING, pump 55mm dia UCC/Parker	1
*15	V603659	/1594	COUPLING, pump 53mm dia KTR	1
*16	147320303	1593/	SLEEVE, coupling, UCC/Parker	1
*16	V603660	/1594	SLEEVE, coupling, KTR	1
17		SCREW (see engine parts catalogue)	1
18		WASHER (see engine parts catalogue)	1
*19	V2005345	1593/	COUPLING, engine 55mm dia UCC/Parker	1
*19	V603661	/1594	COUPLING, engine 53mm dia KTR	1
20	V2005344		PULLEY	1
21	305110550		KEY, parallel	1
* see note below				
25	V2005365		GUARD, belt drive	1
26	V2005367		PLATE	1
27	V2005366		FLANGE, guard	1
28	101S05B		RIVET	4
30	V2005589		GUARD, engine	1
31	101S05D		RIVET	2

Note:- Up to Serial numbers 1593 UCC/Parker Pump-Engine Couplings and Sleeve assemblies where fitted. From Serial numbers 1594 KTR Pump-Engine Couplings and Sleeve assemblies replaced the UCC/Parker components. The individual component items from the two manufacturers are not interchangeable but the complete assemblies are. If a replacement UCC/Parker engine or pump coupling is required, either part number V2005345 or V2005346, order a complete replacement KTR Coupling Assembly under part no V2005762. The UCC/Parker Sleeve, part no 147320303 is still available and can be ordered separately if required for machines with UCC/Parker couplings.

1 **WINGET**



4 **TD 500**

4A **TD 500HL**

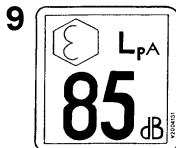
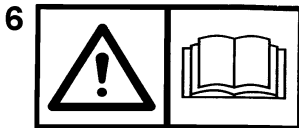
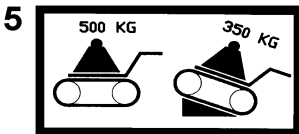

11 **TAKE EXTRA CARE WHEN TIPPING
NON FREE RUNNING LOADS**

12 **SAFETY WARNING**

- 1 Before starting this machine, the operator should be familiar with the operating instructions issued by the manufacturer.
- 2 The manufacturer's rated capacity must never be exceeded.
- 3 Before carrying out any maintenance, servicing, or greasing, always ensure that the engine has been switched off. Never work on a machine while it is running.

W504694600

13 **WARNING
DO NOT WORK UNDER
UNPROPPED SKIP**

14 **WINGET** WINGET LIMITED
P.O. Box 69, Smallhurst Lane, Bolton, Lancs. BL4 0WV
Tel: 01204 658123 Fax: 01204 658296

Model			
Serial No.			
Engine No.			
Capacity	Mass (kg)		
SRO No.	Power (kW)		
Year Of Manuf.	Eng. (rpm)	Drum (rpm)	

A Seddon Group Company

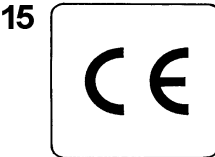

17 **JOHNSON CONSTRUCTION MACHINERY**

MANUFACTURED BY: SEDDONS (PLANT & ENGINEERS) LTD
P.O. BOX 41, BOLTON, LANCOS
Telephone: 01204 63123 Fax: 01204 658472

MODEL	SERIAL No.	
ENGINE	ENGINE No.	
ENGINE POWER	ENGINE R.P.M.	
	MACHINE WEIGHT (KG)	
	YEAR OF MANUFACTURE	

DECALS

4 - A - 1

Item	Part no	Serial no	Description	Qty
1	V2004636		DECAL, "WINGET", 150mm long	2
1A	V2005634		DECAL, "WINGET", 310mm long	2
2	JPP1201		DECAL, "JOHNSON"	2
3	V2004744		DECAL, eye protection	1
4	V2005368		DECAL, "TD500"	2
4A	V2005447		DECAL, "TD500HL"	2
5	V2005369		DECAL, load capacity TD500/TD500HL	1
6	V2004229		DECAL, read operator's handbook	1
7	V2003100		DECAL, hydraulic oil	1
8	V2005311		DECAL, noise LWA 101	1
9	V2004131		DECAL, noise 85 LPA	1
10	10284A01		DECAL, dump/return	1
11	10536A02		DECAL, tipping non free running loads	1
12	504694600		DECAL, safety warning	1
13	DM157		DECAL, do not work under raised skip	1
14	V2003037		PLATE, serial number, Winget	1
.....	101S05B		RIVET, for serial number plate	4
15	V2004223		DECAL, "CE" mark	1
16	V2004281		DECAL, chain drive	1
17	JDD8089		PLATE, serial number, Johnson	1
.....	101S05B		RIVET, for serial number plate	2

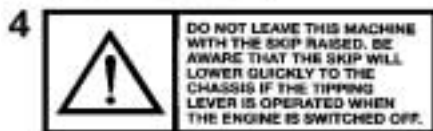
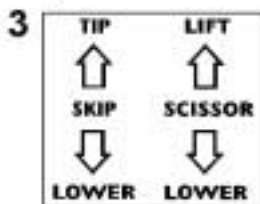

5 TRACKED POWER DUMPER

6 **HONDA** TRACKED POWER DUMPER

DECALS

4 - A - 2

Item	Part no	Serial no	Description	Qty
1	V2003598		DECAL, British made	1
2	V2005448		DECAL, Do not track machine	1
3	V2005421		DECAL, Control valve operation	1
4	V2004798		DECAL, Don't leave skip raised	1
5	V2005635		DECAL, Tracked Power Dumper	2
6	JD8090		DECAL, Honda Tracked Power Dumper (Supplied in sets one LH, one RH)	1