

# **WINGET**

## **OPERATION, MAINTENANCE & SPARE PARTS MANUAL**

### **MODEL R27 TURBOMIXER**

**PUBLICATION No S69  
PRINTED JULY 1969  
REPRINTED JUNE 2003**

**WINGET LIMITED  
PO BOX 41  
EDGEFOLD INDUSTRIAL ESTATE  
PLODDER LANE  
BOLTON  
LANCS  
BL4 OLS**

**TEL: ++ 44 (0) 1204 854650  
FAX: ++ 44 (0) 1204 854663  
service@winget.co.uk  
parts@winget.co.uk  
www.winget.co.uk**

# **WINGET**

# **TURBOMIXER**

## **MODEL R27**

### **WITH FLEXITORS**

### **INTERNAL DRIVE**

### **CAPACITY 39/27 CU FT**

This manual is a reprint of the Winget publication No 69 last printed during July 1969 and is a direct copy of one of the remaining original manuals.

Winget Limited have always operated a policy of continuous product development. Therefore, some illustrations or text within this publication may differ from your machine. The contents of this manual although correct at the time of publication in July 1969, may have be subject to alteration by the manufacturers in the intervening years without notice and Winget Limited can accept no responsibility for any errors or omissions contained within the following pages. Nor can we accept any liability whatsoever arising from the use of this manual howsoever caused.

## **IMPORTANT**

Your WINGET FEIMERT TURBOMIXER is a High Speed Mixer.

The mix should never be allowed to remain in the pan for a period in excess of twice the mixing time required for any particular mix, otherwise, heavy overloading of the gearbox will result.

Average mixing times are given on page 3 within the Description & Operating Instructions section of this manual.

Recourse to a wet hopper should be arranged if the take off from the plant is erratic.

Under no circumstances should the Mixer be stopped and re-started during the mixing cycle.

## LIST OF CONTENTS

### DESCRIPTON and OPERATING INSTUCTIONS

SPECIFICATION	1
INSTALLATION	2
General	2
Air Operated Discharge - if fitted	2
Electrical System	2
WATER SYSTEM - if fitted	2
PRE-RUNNING CHECKS	3
OPERATION	3
Mixing	3
Discharging	4
Cleaning Mixer	4

### OVERHAUL and MAINTENANCE INSTRUCTIONS

LUBRICATION	6
Gearbox - Topping Up	6
Oil Change	6
Gearbox Bearing and Seal Lubrication	7
Mixing and Scraper Blade Tensioning Spring	7
REPLACEMENT OF WEARING PLATES	7
MIXING AND SCRAPER BLADE ADJUSTMENT and REPLACEMENT	8
Pre-Tension "Flexitors"	8
ROTOR, GEARBOX and MOTOR REPLACEMENT	9
DISCHARGE DOOR AIR FILTER and OIL FOG MIST LUBRICATOR	11
DISCHARGE DOOR CYLINDER ADJUSTMENT and SERVICING	11
LUBRICATION and SERVICING SCHEDULE	14

### SPARE PARTS SECTION

HOW TO FIND A SPARE PART	15
SPARE PARTS ASSEMBLY GROUPS	15

## SPECIFICATION

Batch Feeding Based on 34-44 Batches per hour.

MODEL		R 12	R 27	R 54
BATCH	Input	16-18 Cu.Ft.	39 Cu.Ft.	78 Cu.Ft.
	Output	12 Cu.Ft.	27 Cu.Ft.	54 Cu.Ft.
OUTPUT	Cu.Yds. per hour	15-20	34-44	68-88
MOTOR	H.P.	20	45	75
	R.P.M.	1440	720	720
WEIGHT	Lbs.	4150		13,570
	Kilos	1880		6.150
NUMBER OF MIXING BLADES		5	9	12

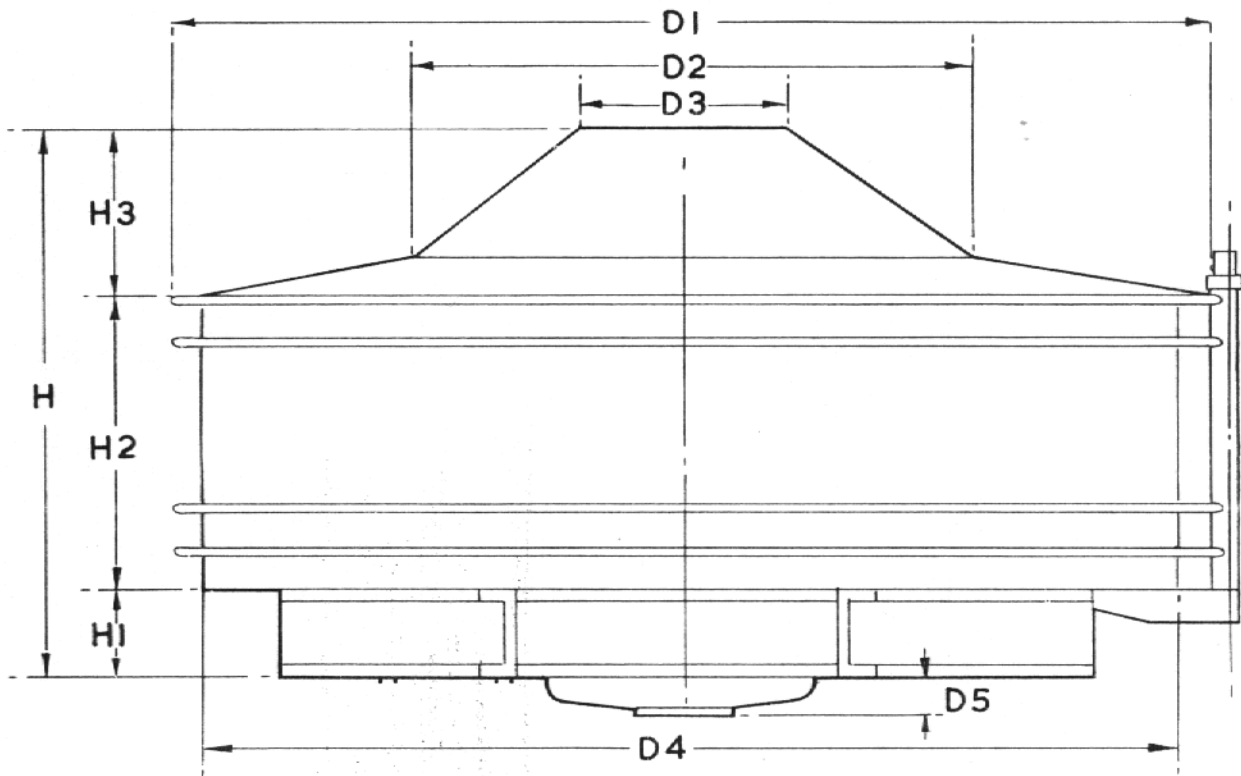

MODEL	R 12		R 27		R 54	
	Ins.	MM.	Ins.	MM.	Ins.	MM.
H	45¾	1,160	57½	1,462	69½	1,767
H1	5	127	8	203	8	200
H2	22¾	580	27¼	694	33½	850
H3	17¾	454	22¼	565	26	660
D1	70¾	1,797	107½	2,734	132¾	3,372
D2	44½	1,128	64	1,626	100	2,542
D3	16	406	20	508	43¾	1,100
D4	67¾	1,721	102½	2,607	131¼	3,334
D5	—	—	—	—	8⅝	221

## **Description & Operation**

## DESCRIPTION AND OPERATING INSTRUCTIONS

### INSTALLATION

General : The mixer must be installed in its working position ensuring that it is mounted horizontally, and that there is not any distortion of the base frame. Provision should be made below the mixer, to allow a free circulation of cooling air in and around the electric drive motor. Access to the discharge door(s) from the underside of the mixer is recommended for inspection and maintenance of the mixing blades.

Air Operated Discharge Door(s) - if fitted : The discharge door(s) on some mixers are operated by an air cylinder. The working pressure required is in the range of 80-100 p.s.i. but should not exceed 150 p.s.i.

The air supply is first passed through a filter to remove any dirt or moisture present, and then through an atomizing type airline lubricator.

Leaflets, supplied by the manufacturer, on the operation and servicing of these two units, are included at the back of this Manual. See Page 11 for list of recommended lubricants.

Electrical System : Detailed instructions on the operation and servicing of the equipment will be issued separately.

### WATER SYSTEM - if fitted

A flowmeter mounted on the side of the mixer, gives accurate indication of the amount of water admitted to the mixing pan.

The use of the flowmeter is simple: Lift the protective lid and turn the top rim until the dial is set at "0" with the black pointer. Open the stop valve mounted next to the flowmeter, to discharge the water into the pan; the amount passing through the flowmeter will be recorded in gallons. Turn off stop cock when required amount is discharged.

If the system has been drained it must be cleared of air to allow the flowmeter to function accurately; this is done by passing a large quantity of water through the unit.

Draining the System: During periods of frosty weather it is essential to drain the system. Remember to drain the bowl of the flowmeter by opening the drain tap screwed into the base of the unit.

### PRE-RUNNING CHECKS

- 1) Check the level of oil in gearbox, top up as necessary - see page 6 for access instructions.
- 2) Check 1/16" clearance between blades and pan, adjust as necessary - see page 8.  
It is recommended after any blade adjustment, that the rotor be given a couple of complete turns by hand, to ensure all round clearance of the blades due to any possible distortion of the pan or rotor housing.
- 3) If the mixer is being used for the first time after the electrical circuit has been connected or re-connected, ensure correct rotation of mixing blades.
- 4) If the water system has been drained, re-connect supply and pass a quantity of water through flowmeter to ensure accurate operation.

### OPERATION

Mixing : It is important that the mixing blades are rotating at their full working speed before any material is fed into the pan.

It is recommended that to reduce the mixing time cycle to a minimum, where possible, the cement, water and aggregate be added to the pan simultaneously.

The actual mixing time will vary depending on the type of mix, but should NEVER be less than thirty seconds, the average time being thirty to forty-five seconds.

THE MIX SHOULD NEVER BE ALLOWED TO REMAIN IN THE PAN FOR MORE THAN TWICE THE MIXING TIME REQUIRED FOR ANY PARTICULAR MIX.

The action of the mixing blades and aggregate generates a small amount of heat which will cause the water content to drop and consequently stiffen the mix.

This stiffening would eventually reach a point when it would cause heat in the windings to exceed its normal running temperature causing the thermistor protection unit to stop the motor and not allowing it to restart until the heat has been dissipated in the motor windings.



In the event of the mixer stalling, the discharge door(s) should be opened, water added to the mix and as much concrete as possible shovelled out before any attempt is made to restart the electric motor.

To prevent the accidental starting of the mixer while manhandling concrete out of the pan, the supply fuses must first be removed or the isolating switch locked in the "OFF" position.

Discharging : A hand or air operated semi-circular shaped discharge door (or doors) in the bottom of the mixing pan, allows the concrete to be quickly discharged by the action of the rotating mixing blades.

It is recommended than on a mixer fitted with two or motor discharge doors, that if only one is consistently used for any period, to prevent the unused door(s) from sticking, that it/they be opened after approximately every 10 batches, to remove any grout that will have accumulated in the crevice between the door and pan.

Cleaning the Mixer : At the end of each day's working, or if the mixer is idle for a period of more than two hours, the mixer should be thoroughly washed to prevent concrete setting in the pan or on the mixing blades.

REMEMBER a clean mixer is more efficient, reducing considerably the wear on the pan and mixing blades.

Washing down should be carried out as follows: With the mixing blades rotating, rinse the inside of the pan using a high pressure hose pipe. A quantity of gravel added to the pan will assist in a more intensive cleaning action.

After some minutes, open the discharge door and completely empty the pan. Switch off the motor, lock the isolating switch in the "OFF" position, or remove the supply fuses. Remove top cover and hose down the paddle arms to remove all traces of concrete.

Check the setting of each of the mixing and scraper blades, adjust if necessary and lubricate as described on page 8.

**Maintenance**

## OVERHAUL AND MAINTENANCE INSTRUCTIONS

WARNING - BEFORE ANY MAINTENANCE WORK IS CARRIED OUT ON THE MIXER, THE ISOLATING SWITCH MUST BE LOCKED IN THE "OFF" POSITION, OR THE SUPPLY FUSES REMOVED BY A QUALIFIED ELECTRICIAN.

### LUBRICATION

Gearbox - Topping Up : The level of oil in the box should be checked weekly, a filling plug and dipstick is provided in the top of the gearcase. To obtain access, remove the small circular plate attached to the top cover, rotate the rotor housing by hand until a corresponding cover is visible. Remove this cover and clean around the dipstick and filler plug before checking level of oil or topping up. Use oil of recommended grade only - see "OIL CHANGE".

Oil Change : The gearbox should be drained, flushed with diesel oil and refilled after the first 500 running hours. This procedure should be repeated after 3,000 running hours and subsequently every 5,000 running hours.

The recommended procedure for changing oil is as follows:

1. Run mixer for a short period, lightly loaded to thin down the oil in the gearbox. Alternatively, carry out the oil change at the end of a working day whilst the oil remains warm.
2. Remove the drain plug from the end of the drain extension pipe, to be found on the underside of the mixer and collect the oil in a suitable container, approximately capacity for the R.27 turbomixer is:  
R.27 INT                      29.2 Gallons
3. Replace the drain plug, refill box with diesel fuel and run for about 10 minutes and drain off oil. If possible the box should be left draining overnight.
4. Refill using an oil of recommended grade as listed:  
SHELL                      -                      MACOMA 72  
ESSO                        -                      ESSTIC 78  
REGENT                    -                      CALTEX MEROPA 3  
REGENT                    -                      M.T. GEAR OIL EP 90  
MOBIL                      -                      COMPOUND B.B.

Gearbox Bearing and Seal Lubrication : Two external points for lubricating the top bearings and bottom oil sealing rings are provided, these require lubrication at monthly intervals.

Access to the top grease nipple is gained by removing the access covers as described in the "Topping Up" instructions given previously.

For ease of access the nipple for charging the bottom oil sealing rings is fitted with an extension tube to carry it clear of the underside of the mixer.

### REPLACEMENT OF WEARING PLATES

To assist in the replacement of wearing plates, they have been divided into easily removable sections. After any plates have been replaced, it is recommended as a final check that the rotor housing be turned by hand, to ensure correct adjustment of blades in relation to bottom of pan.

#### Bottom and Inner Plates

1. Remove top cover to expose mixing blades.
2. Remove one mixing arm assembly complete by removing the single bolt attaching it to the rotor housing.
3. Turn the rotor housing by hand, until the mounting brackets of the removed blade is a little to one side of the wearing plate segment to be replaced.
4. Remove the countersunk screws and the wearing plate from the pan.
5. Fit new wearing plate, assemble mixing arm and top cover.

#### Outer Wearing Plate

1. Remove top cover to expose mixing blades.
2. Turn rotor housing by hand, until the outer scraper blade is clear of the segment to be replaced.
3. Remove the countersunk fixing bolts and remove wearing plate from pan. Fit new wearing plate.

### MIXING AND SCRAPER BLADES

Adjustment: The blades should be inspected daily for wear and adjusted if necessary, to give approximately 1/16" clearance between the blade and the bottom or side of pan.

After any adjustments have been made, it is recommended that as a final check before the motor is started that the rotor housing be rotated by hand a couple of times, to ensure that the blades do not foul the pan.

#### Pre-tensioned "Flexitors"

Line up base of "Flexitor" parallel to top edge of mounting block and scribe a straight line across block and serrated shaft. Turn "Flexitor" anti-clockwise until shaft scribe line is offset 2 or 3 serrations from line on mounted block and secure block to shaft in that position. Fig 1

Offer upper edge of "Flexitor" base to underside of rotor arm and position clamp around "Flexitor" and rotor arm. Screw up clamp until "Flexitor" is positioned flush to rotor arm and secure with setscrews. Lift paddle blade 1/16 in. from top of bottom wearing blade and adjust 5/8 in. setscrew until it bears against underside of rotor arm, secure with nut.

NOTE: Screw must only be used as a stop and not for height adjustment.

#### Fitting New Blades : Badly worn blades should be renewed as follows:

1. Open the discharge door and turn the rotor by hand, until the worn blade is over the door opening.
2. Detach the blade by removing the two fixing bolts securing it to the mixing arm.
3. Fit new blade and tighten up bolts with them hard up to the top of the slotted holes in the mixing arm.
4. Reset blade until the correct clearance of 1/16" is obtained, as described above.

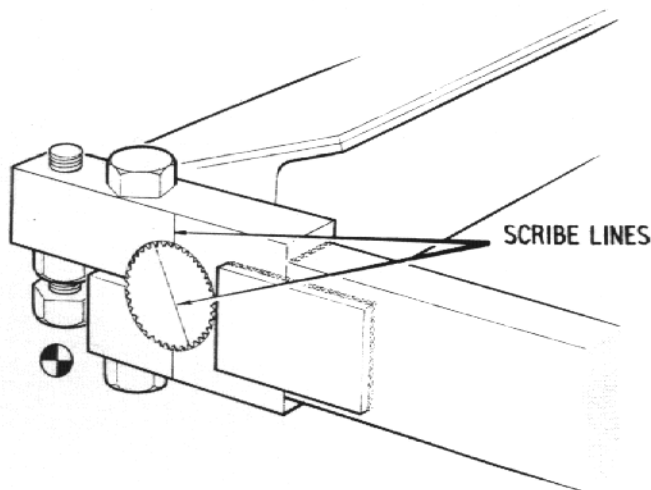

## STAGE 1

LINE UP BASE OF FLEXITOR PARALLEL TO TOP EDGE OF MOUNTING BLOCK AND SCRIBE A STRAIGHT LINE ACROSS BLOCK AND SERRATED SHAFT.

TURN FLEXITOR ANTI-CLOCKWISE UNTIL SHAFT SCRIBE LINE IS OFFSET 2-3 SERRATIONS FROM LINE ON MOUNTED BLOCK.

SECURE BLOCK TO SHAFT IN THAT POSITION.



## STAGE 2

OFFER UPPER EDGE OF FLEXITOR BASE TO UNDERSIDE OF ROTOR ARM.

POSITION CLAMP AROUND FLEXITOR AND ROTOR ARM.

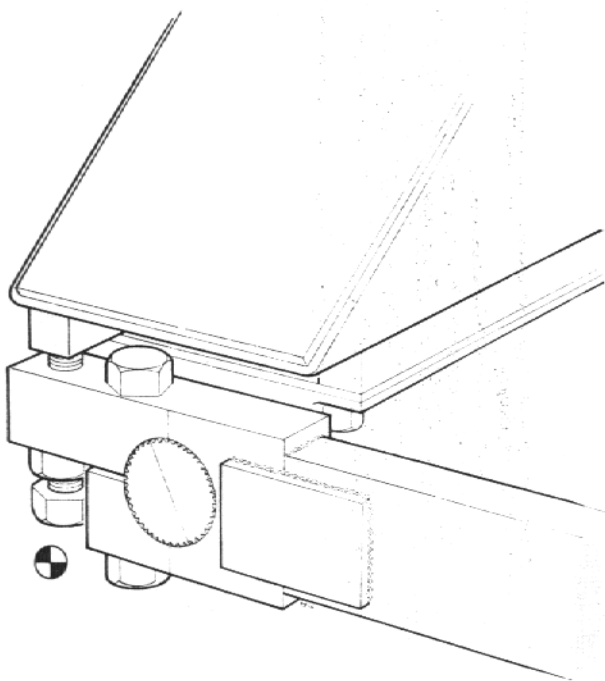
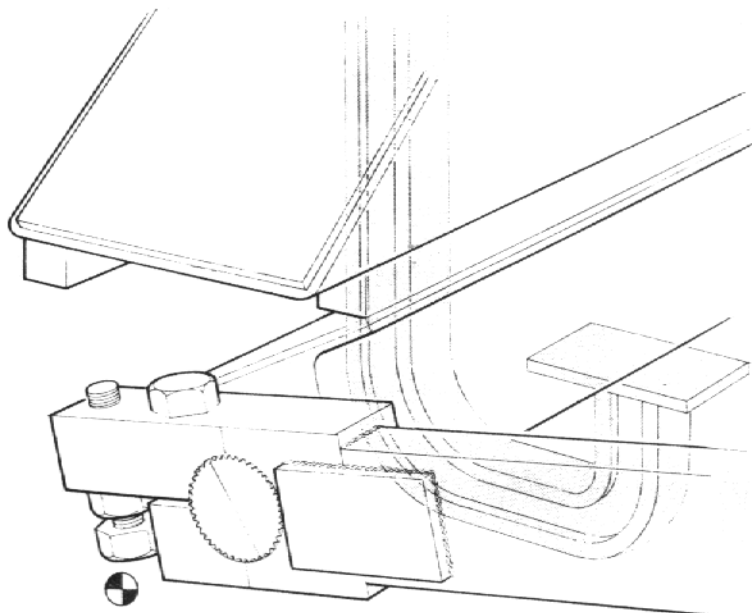

## STAGE 3

SCREW UP CLAMP UNTIL FLEXITOR IS POSITIONED FLUSH TO ROTOR ARM AND SECURE WITH SETSCREWS.

LIFT PADDLE BLADE 1/16 IN. FROM TOP OF BOTTOM WEARING PLATE, ADJUST 5/8 IN. SETSCREW UNTIL IT BEARS AGAINST UNDERSIDE OF ROTOR ARM SECURE WITH NUT.

## NOTE:

⊕ SCREW MUST ONLY BE USED AS A STOP AND NOT FOR HEIGHT ADJUSTMENT.



## ROTOR, GEARBOX AND MOTOR REPLACEMENT

The notes given in this section are intended for general guidance only and may differ in detail over the three different models, R54, R27 & R12:

1. Disconnect the electrical supply from the mixer by removing the fuses and the electrical connections from the motor at the starter switch; these should be clearly labelled to assist in easy reconnection.
2. Drain the oil from the box into a clean container of suitable capacity, by removing the plug from the drain extension pipe located on the underside of the mixer. On some of the larger mixers, flexible extension tubes are fitted which will require unclipping to allow the motor and gearbox to be removed.
3. Lift off the top cover to expose the mixing and scraper blades.  
Remove the three mixing arms complete with the "Flexitor unit" attached to the rotor, by removing the single fixing bolt on each arm.  
Remove the inner scraper blade.
4. Remove the nuts and spring washers securing the rotor housing to the gearbox driving flange.  
Using a pulley block remove the rotor housing from the mixer.
5. Unscrew the bolts securing the gearbox to the pan.  
Hoist the gearbox and motor upwards until the motor is clear of the motor space. A lifting eye is provided on the top of the gearbox for this purpose.
6. Lower the motor to the floor and block it up. With the gearbox still hanging from the pulley block, remove the bolts securing the motor, then carefully raise the gearbox 6 - 8 inches to disengage the motor drive pinion.
7. Remove the bolt and retaining washer from the end of the motor shaft and withdraw the motor pinion and key.

### Fitting New Motor

1. Fit the motor pinion and key onto the motor shaft.  
Clean the top surface of the pinion and the underside of the retaining washer and give them a coating of a suitable sealing compound.  
Place the washer centrally in position and secure with the fixing bolt.  
On some models a locking screw is provided for the purpose of wire locking the pinion fixing bolt.
2. Remove the two old seal rings from the aperture in the base of the gearbox.  
Fit new seal rings ensuring that they are inserted with the flat side of the seal facing downwards and the sealing lips upwards.

### IMPORTANT

THE CAVITY FORMED BETWEEN THE SEALS MUST BE PACKED WITH SHELL "LUCINA" GREASE GRADE "A" BEFORE THE MOTOR IS REMOUNTED.

3. Raise the gearbox and carefully lower it into position on the motor, meshing the motor pinion with its mating gear in the box. Secure motor and gearbox together.  
Ensure that the motor pinion does not score the lip of the sealing rings during assembly.
4. Hoist up the gearbox and motor, lower them into the motor space and secure in position.
5. Fill the gearbox with oil to the correct level as indicated on the dipstick. See page 6 for recommended oil and capacities.
6. Assemble the rotor housing onto the gearbox driving flange and secure in position.
7. Fit the three assemblies and check blade clearance of 1/16". Rotate rotor housing by hand to ensure correct adjustment of blades in relation to bottom of pan.
8. Lubricate the gearbox top bearing and lower sealing rings using SHELL "ALVANIA" or "UNEDO" Grease No. 2.  
On the lower sealing rings the "ALVINIA" or "UNEDO" Grease is used at this and the usual servicing periods to back up the "LUCINA" grease packed into the sealing ring aperture before the motor is refitted.
9. Remake electrical connections to switch gear and replace top cover before using the mixer.

### DISCHARGE DOOR AIR FILTER AND OIL FOG MIST LUBRICATOR

Two leaflets at the end of this publication give full servicing instructions for these units.

Recommended oils for use in the lubricator are as follows:

TELLUS 21	SHELL MIX and BP LTD
NORPOL 35	ESSO PETROLUEM CO LTD
CALTEX SPINDLE OIL A	REGENT OIL CO LTD
MOBILE VELOCITE NO 6	MOBILE OIL CO LTD

### DISCHARGE DOOR CYLINDER CUSHION ADJUSTMENT

A needle valve located to the side of the main inlet port allows adjustment of the cushion.

Turning the valve clockwise will increase the cushioning effect, alternatively an anti-clockwise rotation will reduce it.

The ideal cushion produces a uniform deceleration of the moving parts without shock.



### Cushion setting

Turn the adjusting screw clockwise to its fullest extent and then anti-clockwise for one turn. Operate the cylinder. If bouncing takes place, turn the screw anti-clockwise on half turn. If however, there is a metallic impact from within the cylinder, turn the screw clockwise a fraction. Repeat this until the desired cushioning is achieved.

### SERVICING

The only components subject to any appreciable deterioration are the flexible sealing members fitted to the piston head and those contained within the front end cover.

#### Replacement of Seals

**NOTE:** GENERALLY, REPLACEMENTS MAY BE FITTED WITH THE CYLINDER IN SITU. ALL SEALS MUST BE HANDLED CAREFULLY TO PREVENT DAMAGE TO THEIR SEALING EDGES.

**Piston Head:** Remove the end cover through which the piston rod emerges by unscrewing the four socket head screws. Withdraw front end cover, piston rod and piston head assembly from cylinder barrel. Remove the whole piston head assembly from the shaft by unscrewing the three socket head screws. Replace the seals on each of the two halves of the piston head, taking care to reassemble the seals with their flared sealing lips pointing away from each other.

Replace the piston head assembly on the shaft, taking care to locate the split ring in both the shaft and the tapped half of the piston head. Tighten the three socket head screws securely.

Replace the piston head assembly and front end cover into the cylinder barrel, making sure that the piston head seal lips are not pinched between piston head and barrel. Finally, tighten end cover fixing bolts evenly, corner to corner.

**Shaft seal and wiper ring:** Remove the wiper ring and shaft seal retaining circlip from the end cover through which the piston rod emerges.

Apply air to the front of the cylinder. This will eject both the wiper ring, cage and shaft seal. Be sure and remove the air supply from both ends of the cylinder at this stage.

Wrap a strip of thin material over the piston rod flats and slip shaft seal onto rod, ensuring that the flared sealing lips face away from the screwed end of the piston rod.

Wrap a strip of thin material inside nose of the front end cover to protect the larger diameter sealing lip of the seal whilst sliding over the circlip groove.

Fit new wiper seal in cage and replace sub-assembly in end cover, making sure that leading edge of the seal projects through larger diameter of cage and towards screwed end of piston rod - replace circlip.

Cushion seals - blank end cover: Remove from cylinder by unscrewing the four socket head screws. Remove circlip spring washer and bonded cushion seal. Replace seal taking care that the metal insert faces towards the back of the end cover. Replace spring washer and circlip. Re-assemble end assembly, tightening each screw evenly, corner to corner.

Cushion seals - front end cover: Remove from cylinder dismantle piston head assembly. Remove and replace cushion seal as already described. Reassemble piston head and replace whole assembly as described previously.

NOTE: ON NO ACCOUNT MUST THE SHAFT BE REMOVED FROM THE END COVER. IF THIS HAPPENS, THE NECK PACKING SEALS WILL BE DAMAGED - NECESSITATING REPLACEMENT.

#### LOCATION OF SUSPECTED LEAKS

Piston Head: Remove each port connection in turn and test for leak. Subject to bubble test if necessary by leading connection from end cover into still water.

Replace defective seals as described and before re-assembly ensure that the cylinder bore is perfectly free from all foreign materials. Should the cylinder continue to leak past the piston head after replacement seals are fitted, return it to the Works for inspection.

Front End Assembly: Test for leakage by connecting air to front end cover or cylinder and applying soapy water around the rod where it emerges from the end cover. Presence of bubbles indicates a leak. Replace defective seal as described.

If leaks persist, return cylinder to Works for inspection.

## LUBRICATING AND SERVICING SCHEDULE

### DAILY

GENERAL	Thoroughly clean the inside and outside of the mixer paying particular attention to mixing and scraper blades. Give mixer a coating of equal parts of paraffin and engine oil. Apply a little engine oil to all move parts, pin joints on discharge doors, etc.
DISCHARGE DOOR	*        Use grease gun - 2 nipples (4 if double door)
AIR VALVE TOP and BOTTOM PLATE	*        Use grease gun - 2 nipples (4 if double door)

### WEEKLY

GEARBOX	Check oil level - dipstick fitted to top of gearcase. For access, see page 6. Top up with recommended oil only - see page 6.
---------	--

### MONTHLY

GEARBOX	*        Top bearings and bottom sealing rings, use grease gun - one nipple on each. For access, see page 7.
---------	---

\*        -        SHELL "ALVANIA" Grease No. 2 or "UNEDO" Grease No. 2

**Spare**

## **TO FIND A SPARE PART**

The assemblies on this mixer are illustrated at the end of this section. To identify a component, first find the relevant assembly in the list of illustrations given on this page. On turning to this illustration it will enable you to identify the part you require and give you a reference number. Against this number in the parts list will be found the DESCRIPTION and PART NUMBER, information which, we require in addition to your machine serial number and year of manufacture, if known.

Please note that a number of components are described as being c/w screws, nuts and washers, this is no longer the case and all fixings should be ordered separately if required. Imperial fixings may no longer be available and the nearest metric equivalent will be supplied.

### **SPARE PARTS ILLUSTRATIONS**

Group A	Rotor- Paddle Arms and Blades	Page 18
Group B	Gearbox	Page 19
Group C	Air Operated Discharge Door	Page 22
Group D	Mixing Pan Wearing Plates	Page 24
Group E	Discharge Door Operating	Page 25

ROTOR - PADDLE ARMS & BLADES.GROUP "A"

REF. NO.	NO. PER MACHINE.	DESCRIPTION.	PART NO.
A 1	1	Special Rotor to suit Flexitor Mounting.	514-2935
A 2	3	Paddle Arm 'D' (Outer).	514-2936
A 3	2	Paddle Arm 'E' (Central).	514-2937
A 4	3	Paddle Arm 'F' (Inner).	514-2938
A 5	1	Paddle Arm 'G' (Intermediate).	514-2939
A 6	1	Outer Scraper Blade. Complete with Hex. Hd. Bolt, Binx Nut and Spring Washer.	514-2940
A 7	1	Inner Scraper Blade Support. Complete with Hex.Hd. Bolts, Nuts and Spring Washers.	514-2941
A 8	1	Inner Scraper Blade. Complete with Hex. Hd. Bolt with Binx Nut - Hex Nut and Plain Washer.	514-2942
A 9	5	L.H. Paddle Blade (Flat Faced) Standard.	514-2954
A 9a	5	L.H. Paddle Blade (Bulbous Faced) Optional Extra.	514-1066
A 10	1	Intermediate Paddle Blade (Flat Faced) Std.	514-2955
A 10a	1	Intermediate Paddle Blade (Bulbous Faced). Optional Extra.	514-1258
A 11	3	Paddle Blade Inner. (Flat Faced) Standard.	514-2958
A 11a	3	Paddle Blade Inner. (Bulbous Faced). Optional Extra.	514-1620
A 12	18	Bolts for Paddle Blade. Complete with Binx Nuts.	514-1624
A 13	18	Paddle Blade Washer.	514-1625
A 14	3	Cover for Rotor Complete with Hex. Head Setscrew and Spring Washers.	514-1580.
A 15	9	Flexitor Suspension Unit. Complete with Hex. Head Setscrews and Spring Washers.	220705
A 16	9	H.T. Hex. Head Bolts with Nut and Spring Washers.	40621026
A 17	9	Hex. Head Setscrew with Nut.	41831020

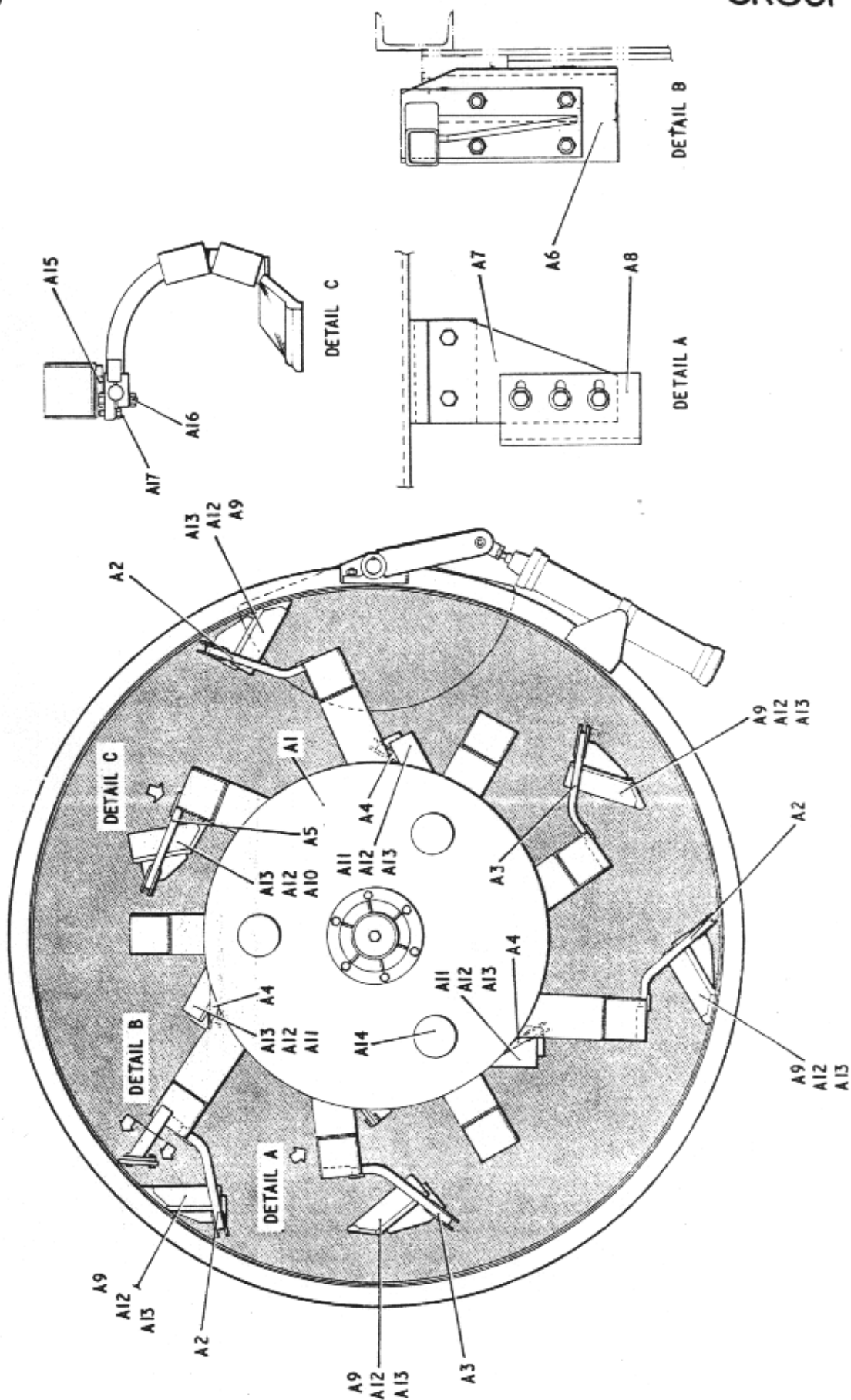

ROTOR-PADDLE ARMS & BLADES

GEARBOX.GROUP "B"

REF. NO:	NO: PER MACHINE.	DESCRIPTION.	PART NO:
B 1	1	Lubrication Hole Cover with Bolt and Spring Washer.	514-1571/4
B 2	1	Top Cover Complete with Screws.	514-1571
B 3	1	Gear Case with Setscrews and Spring Washer.	FB2-197
B 4	1	Gear Cover with Setscrew and Spring Washer.	FB2-186
B 5	1	Dipstick.	514-1223
B 6	5	Setscrew for Gear Wheel No. 6.	41841012
B 7	2	Grease Nipple.	333102.3
B 8	1	Parallel Key.	FB1-31/16
B 9	1	Drive Flange.	FB4-91
B 10	1	Output Shaft Washer.	FB2-185-4
B 11	1	Eyebolt with Spring Washer.	460620
B 12	1	Setscrew for Driving Flange.	40511012
B 13	6	Nut and Spring Washers for Bolts on Driving Flange.	330312
B 14	1	Main Shaft Bearing Upper.	FB1-31/19
B 15	1	Shaft for Gearwheel No. 6.	FB2-185-23
B 16	1	Main Shaft Roller Bearing.	FB1-31/18
B 17	1	Gearwheel No. 5.	FB4-283M10-227
B 18	1	Dowel Pin.	FB1-31/62
B 19	1	Gasket.	FB1-31/27
B 20	1	Washer for Gear No. 1.	FB4-280-5
B 21	1	Washer for Gear No. 2. & No. 3.	FB4-280-1
B 22	1	Csk. Screw for Item. 77.	40021010



GROUP "B"

REF. NO:	NO: PER MACHINE	DESCRIPTION.	PART NO:
B 23	1	Special Thrust Race.	FB4-70
B 24	1	Roller Bearing for Gear No. 3.	FB1-31/15
B 25	1	Shaft for Gearwheels No. 2. & 3.	FB4-183
B 26	1	Gearwheel No. 3.	FB4-27AM-7220
B 27	1	Ball Bearing for Gearwheel No. 2.	FB1-31/8
B 28	1	Gearwheel No. 2.	FB4-273M-5-Z-23
B 29	1	Dowel Pin.	FB1-31/28
B 30	6	Csk. Screw with Special Washers for Item. B 25.	40021016
B 31	1	Distance Piece.	FB4-212-3
B 32	1	Internal Circlip.	1323160
B 33	1	Motor Pinion for Gearwheel No. 1.	FB2-125M-5-Z-23
B 34	1	Key for Motor.	FB1-31/60
B 35	1	Csk. Screw for Item B 20.	40021016
B 36	2	Motor Pinion Oil Seals.	<del>MA</del> 13016014
B 37	1	Shaft for Gearwheels, No's 4 & 5.	FB4-184
B 38	7	Setscrew with Washer for Item B37.	41841016
B 39	2	Hose Clip.	132120
B 40	2	Hose Clip.	132101
B 41	1	Plastic Oil Drainpipe.	FB1-31/29
B 42	1	Plastic Grease Pipe.	FB1-31/30
B 43	1	Oil Drain Tube Outlet.	FB3-191-48
B 44	1	Grease Tube Outlet.	FB3-191-5
B 45	1	Plug.	241708

GROUP "B"

REF. NO:	NO: PER MACHINE.	DESCRIPTION.	PART NO:
B 46	1	Gearwheel No. 4.	FB4-282-M7-Z90
B 47	1	Ball Bearing for Gearwheel No. 4.	FBI-31/16
B 48	1	Gearwheel No. 6.	FB2-185-IM10-2.56
B 49	1	Roller Bearing for Gearwheel No. 5.	103712
B 50	1	Washer for Gearwheel No. 4 & 5	FB4-280-Z
B 51	1	Csk. Screw for Item B.50	40021010
B 52	1	Water Deflector.	514 2881
B 53	1	Washer for Gearwheel No 4 & 5.	FB4-280-Z
B 54	1	Csk. Screw for Item 60.	40021010
B 55	1	Dowty Bonded Seal.	417865
B 56	1	"Asea" Electric Motor	-
		or	
	1	45 MP. Ecc Flange Mounted Electric Motor.	-
		or	
	1	Newman Motor. All complete with Bolts and Spring Washers. (Not illustrated).	-

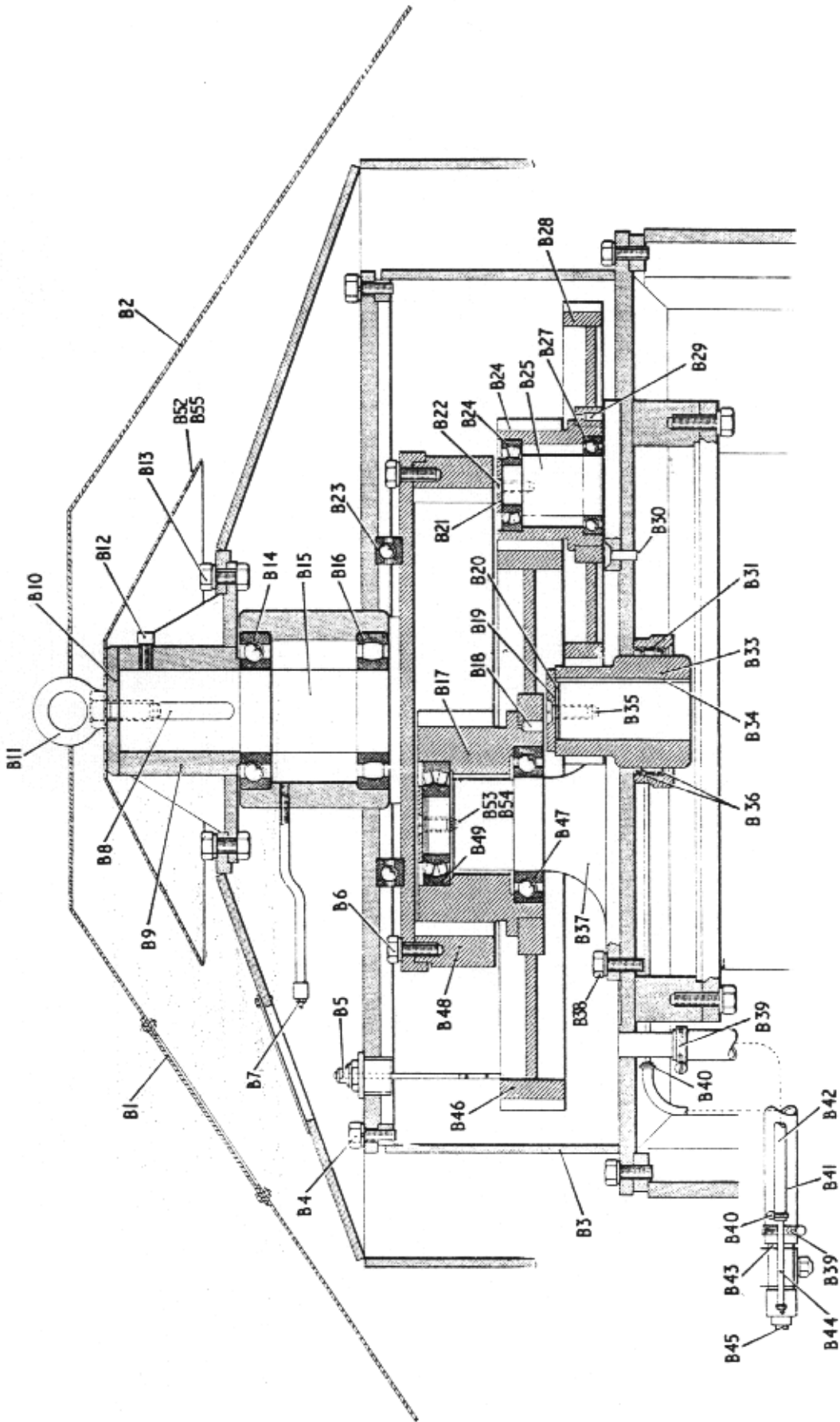

AIR OPERATED DISCHARGE DOOR.GROUP "C"

REF. NO:	NO: PER MACHINE.	DESCRIPTION.	PART NO:
C 1	1	Discharge Door Outlet.	514-1532
C 2	1	Discharge Door.	514-1533
C 3	1	Adjusting Sleeve complete with Hex. Head Setscrew with Spring Washers.	514-1534
C 4	1	Door Shaft.	514-1535
C 5	1	Door Shaft Bearing.	514-1536
C 6	2	Air Operated Door Lever.	514-1537
C 7	1	Swivel Block.	514-1538
C 8	1	Swivel Block Pin complete with Plain Brk. Washer and Split Pin.	514-1539
C 9	2	Pivot Plate complete with Hex. Head Bolts, Nuts and Spring Washers.	514-1524
C 10	1	Discharge Door Sealing Strip.	514-1540
C 11	8	Sealing Strip Clamp complete with Hex. Nuts and Spring Washers.	514-1541
C 12	1	Thrust Bearing.	111210
C 13	1	Gib Hd. Key.	30110844
C 14	1	Feather Key.	30510828
C 15	2	Collars.	-
C 16	2	Socket Setscrews.	40350812
C 17	1	Socket Setscrews.	40350612
C 18	2	Straight Grease Nipple.	33310402
C 19	2	35° Grease Nipple.	33375202
C 20	11	Csk. Head Screw with Hex. Nut and Spring Washer.	40020814

GROUP "C"

---

REF. NO:	NO: PER MACHINE.	DESCRIPTION.	PART NO:
C 21	5	Csk. Head Screw with Hex. Nut and Spring Washer.	40020818
C 22	2	Csk. Screw with Hex. Nuts and Spring Washers.	40021026
C 23	1	Locknut.	331216
C 24	1	Air Cylinder. <i>137198000</i>	137125041
C 25	1	Oil Fog Vitalizer Unit.	451502
C 26	1	Three Positioned Index Five Port-Air Valve.	450495
C 27	2	Exhaust Hoods.	4504033
C 28	2	Reducing Bush.	240504202
C 29	7	Brass Hose Connectors.	1303044
C 30	1 length	Rubber Hose 20' 0" long	260303
C 31	7	Clips.	132110
C 32	2	Pivot Plate Packers.	514-1587

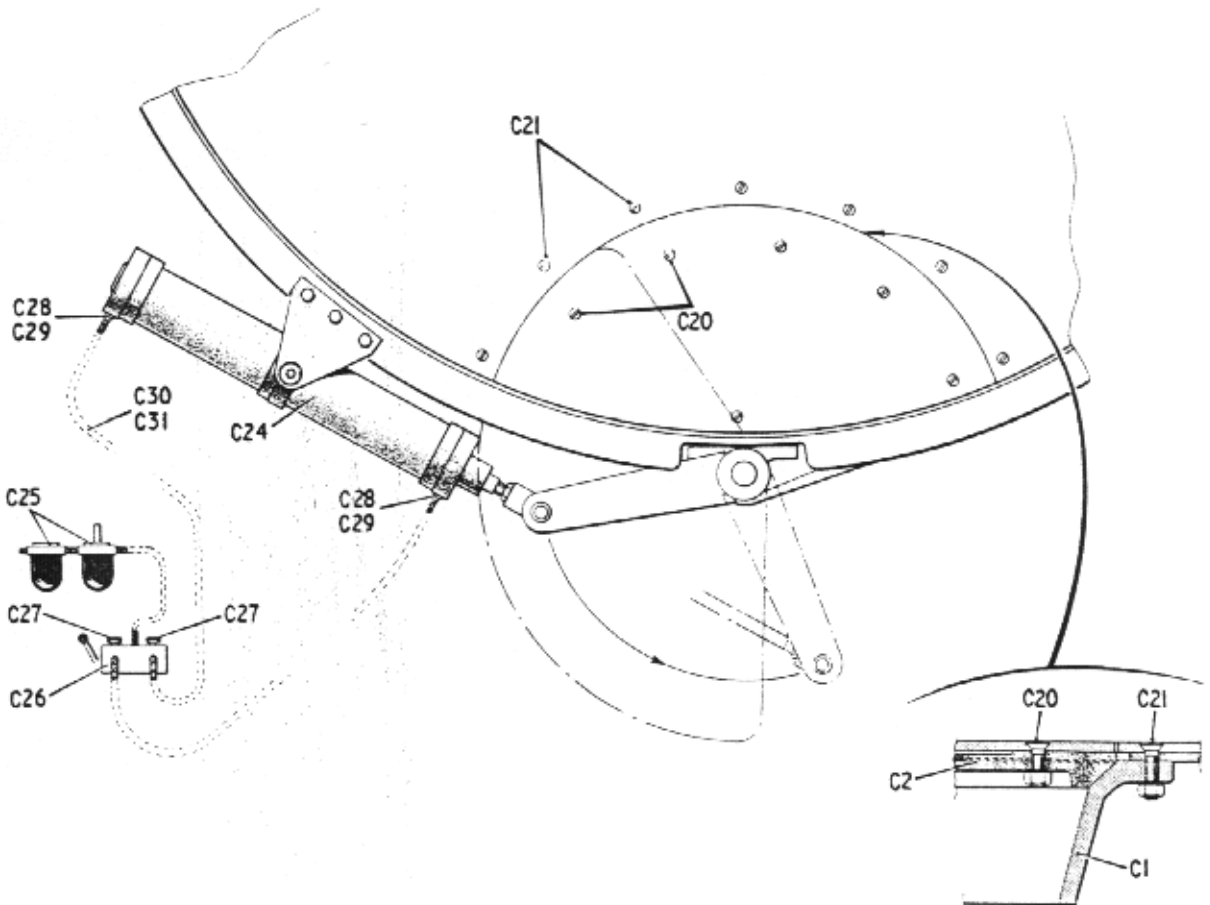
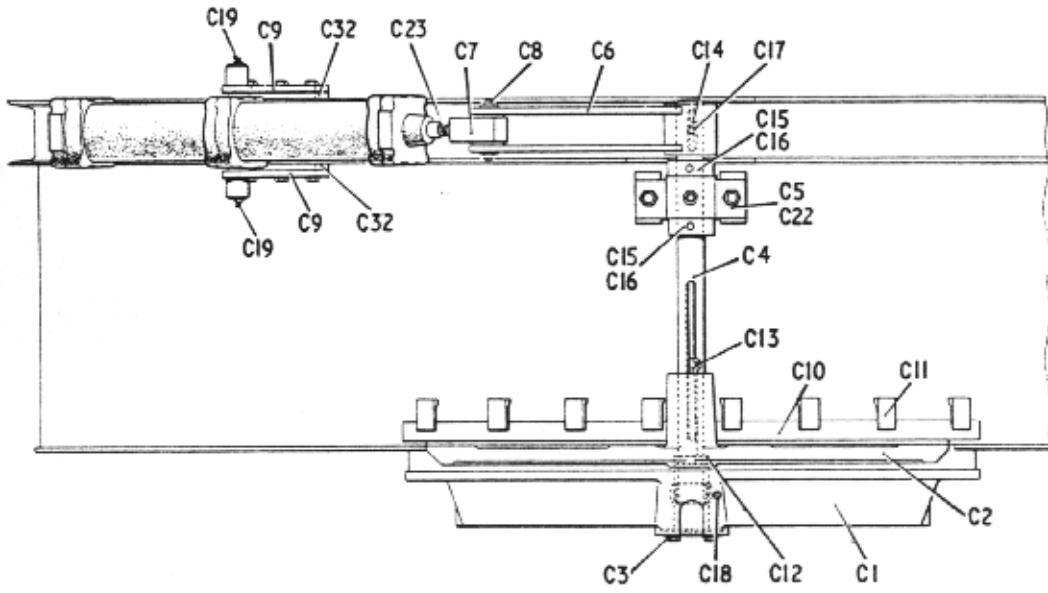

AIR OPERATED DISCHARGE DOOR

MIXING PAN WEARING PLATES.GROUP "D"

---

REF. NO:	NO: PER MACHINE.	DESCRIPTION.	PART NO:
D 1	6	Outer Wearing Plates. Complete with Screws Nuts and Spring Washers.	514-1552
D 2	3	Inner Wearing Plates. Complete with Screws Nuts and Spring Washers.	514-1553
D 3	10	Pan Bottom Wearing Plate.	514-1554
D 4	1	Door Outlet Wearing Plate. Right Hand.	514-1555
D 5	1	Door Outlet Wearing Plate. Left Hand.	514-1556
D 6	1	Door Wearing Plate.	514-1557
D 7	8	Pan Bottom Wearing Plates.	514-1554
D 8	2	Door Outlet Wearing Plate. Right Hand.	514-1555
D 9	2	Door Outlet Wearing Plate. Left Hand.	514-1556
D 10	2	Door Wearing Plates.	514-1557
D 11	6	Pan Bottom Wearing Plates.	514-1554
D 12	3	Door Outlet Wearing Plate. Righ Hand.	514-1555
D 13	3	Door Outlet Wearing Plate. Left Hand.	514-1556
D 14	3	Door Wearing Plates.	514-1557

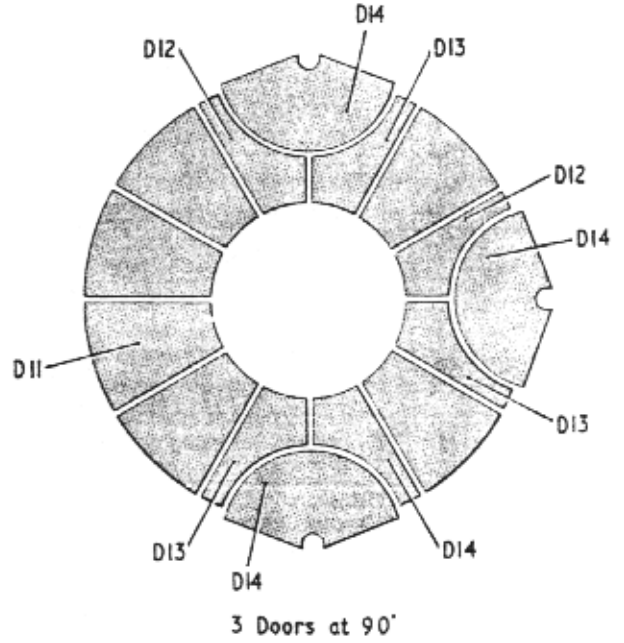
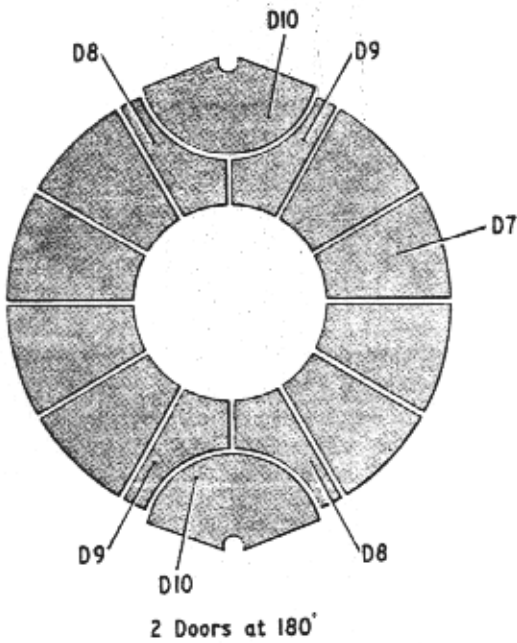
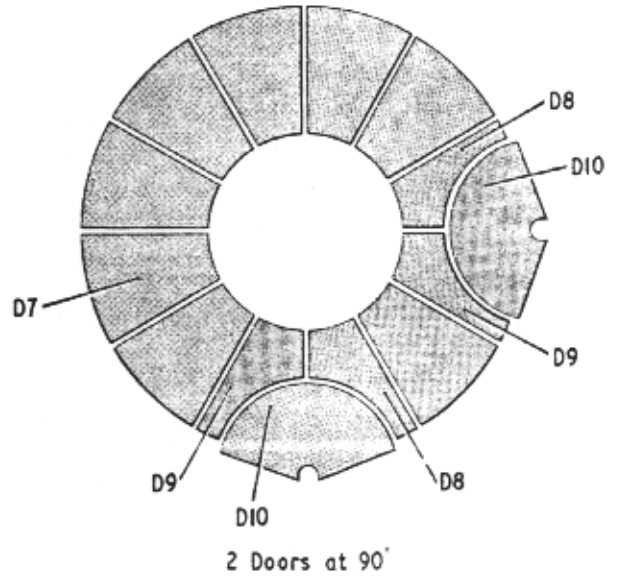
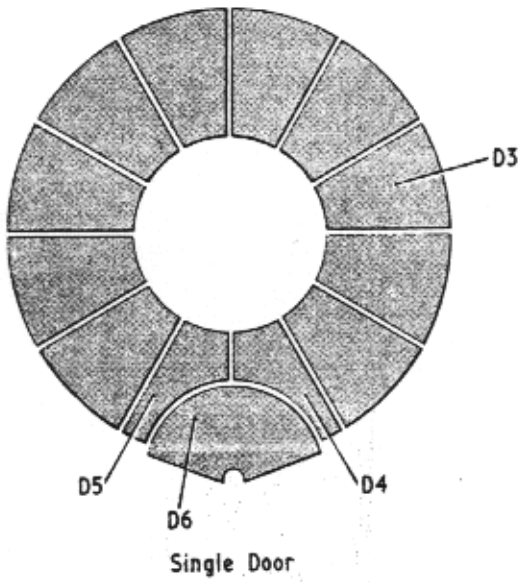
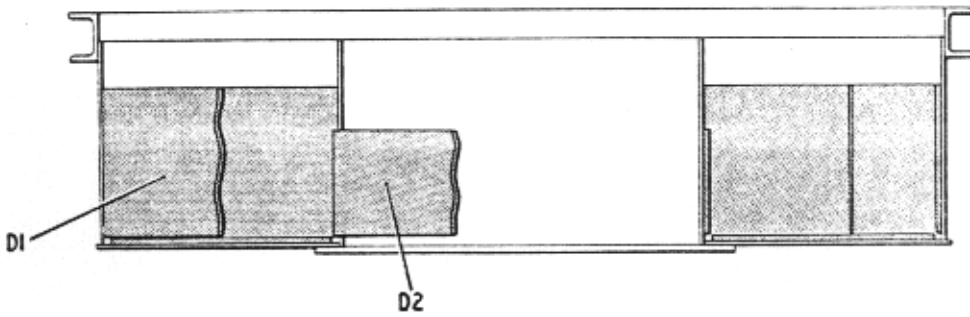



DISHCHARGE DOOR OPERATING RAM.GROUP "E"

REF. NO:	NO: PER MACHINE.	DESCRIPTION.	PART NO:
E 1	1	Cage.	009805
E 2	1	Neck Packing.	014982
E 3	1	Bearing Bush.	009806
E 4	2	Circlip	009803
E 5	1	Tube.	009792
E 6	2	Distributor Seal.	SP 66
E 7	1	Follower.	009796
E 8	4	Screws	SP 71
E 9	1	Retaining Ring.	SP 668
E 10	1	Wiper Ring.	SP 67
E 11	2	'O' Ring.	SP. 62
E 12	2	Ring.	MO09802
E 13	1	Head (Tapped)	MO15874/3
E 14	4	'O' Ring.	SP. 63
E 15	1	Ring Split.	009795
E 16	1	Head (C' Bored)	MO15875/3
E 17	1	Rod (Cyl. Type).	L.013705
E 18	1	End.	L.009808
E 19	2	Cushion Seal.	009798
E 20	2	Retaining Ring.	SP. 669
E 21	2	Washer.	009800
E 22	2	Circlip	SP.422
E 23	2	Sleeve.	MO.15876/3

GROUP "E"

---

REF. NO:	NO: PER MACHINE.	DESCRIPTION.	PART NO:
E 24	2	Escutcheon.	009810
E 25	4	Rivet.	SP.35
E 26	2	'O' Ring.	SP 94.
E 27	2	Screw	009809
E 28	1	End.	L.009804

---

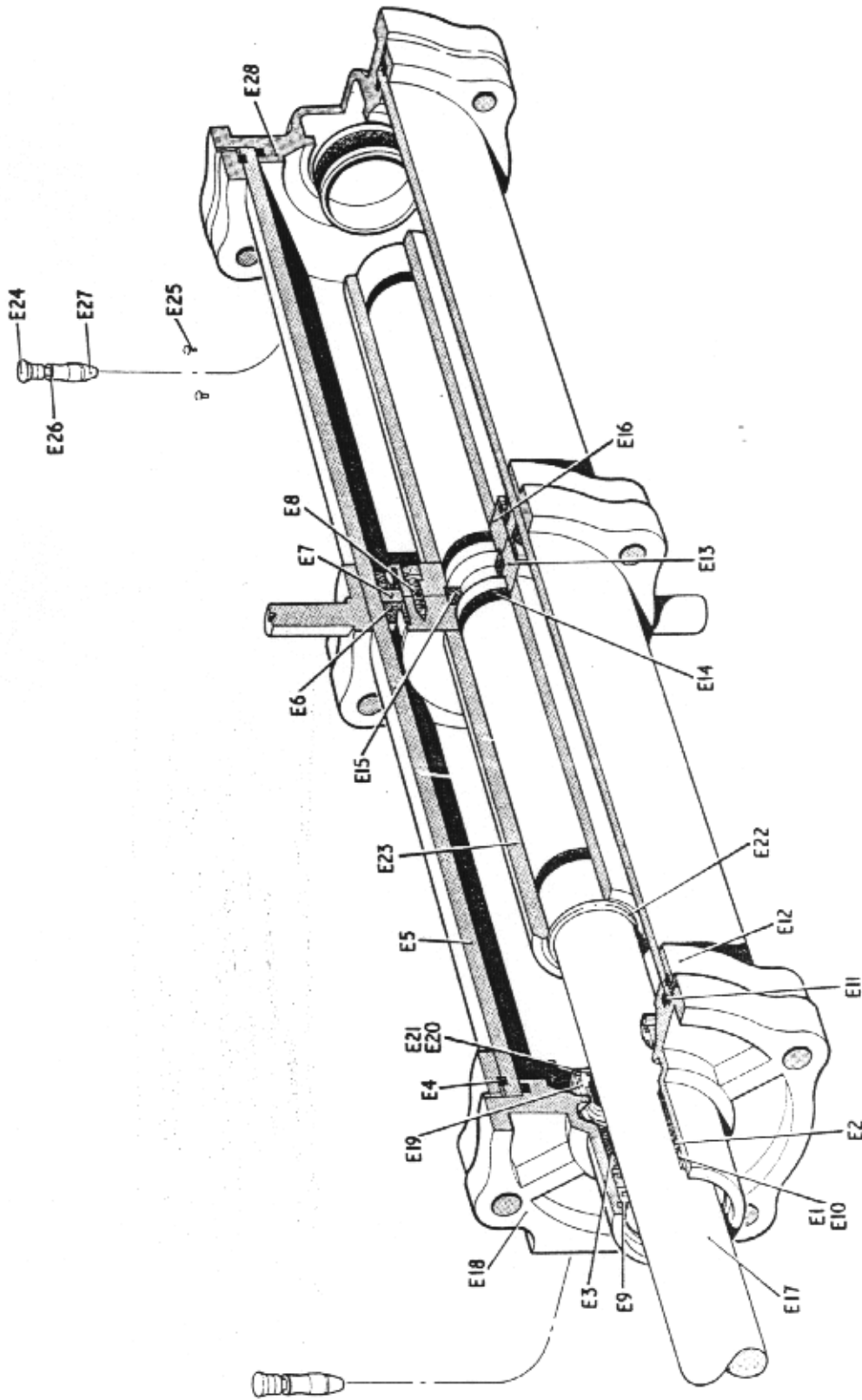

DISCHARGE DOOR OPERATING RAM

## OIL-FOG LUBRICATORS

Series 041E, 042E, S406E, X400E, Y400E,  
 $\frac{1}{4}$ " ,  $\frac{3}{8}$ " ,  $\frac{1}{2}$ " ,  $\frac{3}{4}$ " , 1" ,  $1\frac{1}{4}$ " and  $1\frac{1}{2}$ " pipe sizes.  
 Series 039E, 040E,  $\frac{1}{4}$ " , and  $\frac{3}{8}$ " sizes.  
 Series 10-026, 2" size.

TRANSPARENT BOWL

Max. Pressure: 150 p.s.i. Max. Temp.: 120°F.

METAL BOWL

Max. Pressure: 250 p.s.i. (X400E, Y400E and 10-026, 150 p.s.i.) Max. Temp.: 175°F.

### INSTALLATION

Install close to component being served and downstream from filter and regulators. Arrows on collar visible through sight glass (1) indicate direction of air flow. To reverse direction of flow remove top plug (2) and drip gland (3) and turn venturi tube (4) 180° with screwdriver. (Series 10-026 unit is not reversible. Direction of flow left to right only). One lubricator recommended for two devices (max.). Keep valves, elbows, joints, to minimum between unit and devices being lubricated. Fill with oil through filler plug (5).

Note: If soluble or additive type oil (graphite or molybdenum disulphide) is used, remove felt disc (6), ensuring male cone of pressure disc (9) faces downwards on reassembly.

Lubricant Specification. Recommended list of oils is available. Preferably consult maker of device to be lubricated for correct oil. Compound oils containing soap, fillers, etc., are not recommended.

### OPERATION

To adjust, slacken knurled lock nut (7), close needle (8) fully, turn on air and open needle until required oil flow is seen through sight glass (approx: 1 drop of oil required per 10 c.f.m.). Tighten knurled lock nut after adjustment.

Note: Series 10-026 units are provided with a tamper-proof cap. This must be removed prior to adjustment. If venturi bushing is required, insert from inlet or outlet port and line up holes to receive stem of venturi tube. To clean plastic bowls wash in SOAPY WATER ONLY.

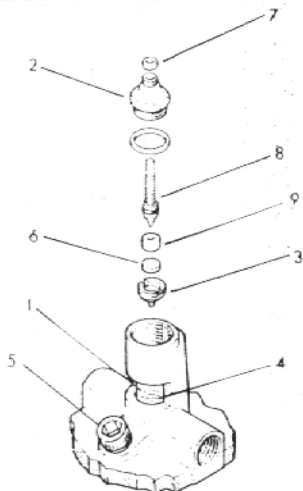

LUBRICATOR ADJUSTMENTS

### OLIELEVEL-SMEERAPPARATEN

behorende tot de series: 041E, 042E, S406E, X400E, Y400E, voor pijpmaten van  $\frac{1}{4}$ " ,  $\frac{3}{8}$ " ,  $\frac{1}{2}$ " ,  $\frac{3}{4}$ " , 1" ,  $1\frac{1}{4}$ " en  $1\frac{1}{2}$ ".

Series 039E, 040E voor de maten  $\frac{1}{4}$ " en  $\frac{3}{8}$ ".

Series 10-026 voor de maten 2".

DOORZICHTIG RESERVOIR

Max. druk: 10,5 kg/cm<sup>2</sup>. Max. temp.: 50°C.

METALEN RESERVOIR

Max. druk: 18 at (X400E, Y400E en 10-026, 10,5 at.)

Max. temp.: 80°C.

INSTALLATIE

Opstellen in nabijheid van te smeren apparatuur achter filters en reguleurs. De pijl op de kraag, zichtbaar door het kijkglas (1), geeft de richting van de luchtstroom aan. Om de luchtstroom om te keren moeten de bovenste plug (2) en de druppel gland (3) worden verwijderd; daarna de venturibus (4) 180° verdraaien met een schroevendraaier. (Serie 10-026: deze apparaten zijn niet omkeerbaar. Stromingsrichting alleen van links naar rechts.) Aanbevolen wordt per apparaat niet meer dan twee smerplaatsen te bedienen. Beperk het aantal kleppen, bochten en verbindingen tussen het smerapparaat en de smerpunten tot een minimum. Olie vullen door opening van vulplug (5)—dit kan worden gedaan terwijl de luchtdruk 'aanstaat'. Opmerking: Indien een speciale mengolie of toevoeging wordt gebruikt, (grafiet of molybdeenbisulfide), moet het viltplaatje (6) worden verwijderd, er zorg voor dragend dat de conus van het drukplaatje (9) bij het monteren weer naar beneden wijst.

Specificatie smeermiddel. Er bestaat een lijst van aanbevolen oliesoorten. Het is raadzaam de fabrikant van het te smeren apparaat te raadplegen omtrent de juiste oliesoort. Compound olie die zeep of vulmiddelen e.d. bevat, dient te worden vermeden.

WERKING

Voor de juiste afstelling eerst kartelcontraeroer (7) losdraaien, naald (8) helemaal indraaien, luchttoevoer aanzetten, naald uitdraaien, tot de gewenste olieloop door het kijkglas wordt waargenomen. (Per 0,28 Nm<sup>3</sup>/min. is ongeveer 1 druppel olie nodig). Draai na deze instelling pakkingmoer aan (vroegere modellen) of draai kartelcontraeroer.

N.B. Serie 10-026. Deze apparaten zijn voorzien van een speciaal deksel om het openen door onbevoegden te voorkomen. Dit deksel moet worden verwijderd voor het afstellen. Indien venturibusjes vereist zijn, breng deze dan aan van in- of uitlaatpoort en zet de gaatjes in lijn voor steel van venturibusjes. De plastic kolf mag ALLEEN GEREINIGD WORDEN MET ZEEPWATER.

### HUILEURS TYPE BROUILLARD D'HUILE

Séries 041E, 042E, S406E, X400E, Y400E, de  $\frac{1}{4}$ " ,  $\frac{3}{8}$ " ,  $\frac{1}{2}$ " ,  $\frac{3}{4}$ " , 1" ,  $1\frac{1}{4}$ " et  $1\frac{1}{2}$ ".

Séries 039E, 040E, de  $\frac{1}{4}$ " ,  $\frac{3}{8}$ ".

Séries 10-026, de 2".

CUVE TRANSPARENTE

Pression max.: 10,5 kg/cm<sup>2</sup>.

Température max.: 50°C.

CUVE METALLIQUE

Pression max.: 18 kg/cm<sup>2</sup> (X400E, Y400E, et

10-026, 10,5 kg/cm<sup>2</sup>.)

Température max.: 80°C.

MONTAGE

Monter à proximité du dispositif à desservir et en aval du filtre et des régulateurs. Les flèches du venturi visibles à travers le verre compte-gouttes (1) indiquent le sens de circulation de l'air. Pour inverser le sens de circulation, enlever le bouchon supérieur (2) et le presse-étoupe compte-gouttes (3) et tourner le tube venturi (4) de 180° avec un tournevis. (Les modèles de la série 10-026 ne sont pas réversibles, l'écoulement se faisant uniquement de gauche à droite.) Un graisseur est recommandé pour un maximum de deux dispositifs à lubrifier. Réduire au minimum le nombre de robinets, coudes, joints, entre l'appareil et les dispositifs à lubrifier. Remplir d'huile par le bouchon de remplissage (5). Ce remplissage peut s'effectuer lorsque la conduite est sous pression. Nota: Si l'on emploie de l'huile soluble ou du type à additif (graphite ou bisulfure de molybdène), enlever le disque en feutre (6) en s'assurant que le cône mâle du grain de pression (9) est dirigé vers le bas au remontage.

Spécification des huiles. Nous pouvons fournir une liste des huiles recommandées. Consulter de préférence le fabricant du dispositif à lubrifier pour le grade correct d'huile à employer. Les huiles compound contenant des savons, charges, etc., ne sont pas recommandées.

FONCTIONNEMENT

Pour ajuster desserrer l'écrou de fixation moleté (7), fermer complètement le pointeau (8), admettre l'air et ouvrir le pointeau jusqu'à ce que le débit désiré paraisse au travers du verre compte-gouttes (environ 1 goutte d'huile pour chaque 0,28 m<sup>3</sup>/min). Resserrer l'écrou de fixation moleté après réglage.

Nota: Les modèles de la série 10-026 sont livrés avec un dispositif de sureté inviolable qu'il faut retirer avant de procéder au réglage. Si la pose d'un venturi est nécessaire, l'insérer à partir de l'orifice d'entrée ou de sortie, en veillant à faire correspondre les orifices destinés à recevoir la tige du tube. Pour laver les cuves en plastique, employer UNIQUEMENT DE L'EAU SAVONNEUSE.

## NORMALNEBEL-ÖLER

Serie 041E, 042E, S406E, X400E, Y400E.

Rohranschluss  $R\frac{1}{2}$ ,  $R\frac{3}{4}$ ,  $R\frac{1}{2}$ ,  $R\frac{1}{4}$ ,  $R1$ ,  $R\frac{1}{2}$  und  $R1\frac{1}{2}$ .

Serie 039E, 040E. Rohranschluss  $R\frac{1}{2}$  und  $R\frac{3}{4}$ .

Serie 10-026. Rohranschluss  $R2$ .

## KUNSTSTOFFBEHÄLTER

Betriebsdruck: bis 10,5 kg/cm<sup>2</sup>.

Temperaturbereich: bis +50°C.

## METALLBEHÄLTER

Betriebsdruck: bis 18 kg/cm<sup>2</sup> (X400E, Y400E und

10-026, bis 10,5 kg/cm<sup>2</sup>.)

Temperaturbereich: bis +80°C.

## EINBAU

Nahe an der Verbrauchsstelle und nach Druckluftfiltern und Druckreglern einbauen. Die durch das Schauglas (1) sichtbaren Pfeile am Bund zeigen die Richtung des Luftdurchflusses an. Zum Umkehren der Durchflussrichtung wird die Spindelführung (2) samt Düse (3) herausgenommen und die Düse (4) mittels eines Schraubenziehers um 180° verdreht. (Modelle der Serie 10-026 sind nicht umkehrbar. Luftstrom nur von links nach rechts). Für je zwei Schmierstellen (max.) soll ein Öl verwendet werden.

Nur die unbedingte Mindestzahl an Ventilen, Krümmern, Anschlüssen usw. zwischen Öl und den zu versorgenden Einrichtungen verwenden. Öl ist an der Rändelschraube (5) einzugießen; dabei braucht der Luftdruck nicht abgestellt zu werden.

Zur Beachtung: Wenn legiertes Öl oder Öl mit Zusätzen (Grafit oder Molybdändisulfid) verwendet wird, ist die Filzscheibe (6) herauszunehmen und darauf zu achten, dass der vorspringende Dichtungskonus (9) beim Zusammenbau nach unten gerichtet ist.

**Spezifikation des Schmiermittels:** Ein Verzeichnis empfohlener Ölmarken steht zur Verfügung. Zweckmässigerweise wird die Erzeugerfirma der zu schmierenden Einrichtung bezüglich der geeigneten Ölart befragt. Legierte Öle mit Zusätzen von Seife, Füllstoffen usw. sind nicht ratsam.

## BETRIEB

Zum Einstellen wird die gerändelte Mutter (7) gelockert und die Spindel (8) völlig geschlossen. Danach wird die Luft angestellt und die Spindel geöffnet bis der erforderliche Öldurchfluss am Schauglas ersichtlich ist (ungefähr ein Tropfen Öl für je 280 l/min.). Nach dem Einstellen ist die gerändelte Mutter anzuziehen.

Zur Beachtung: Modelle der Serie 10-026 sind mit einer gegen unbefugte Eingriffe geschützten Kappe versehen. Sie muss vor Einstellung abgenommen werden.

Wenn die Venturi-Buchse nötig ist, von Einlass- oder Auslassöffnung einführen und Öffnungen für Aufnahme der Spindel am Venturirohr ausrichten.

Kunststoffbehälter NUR IN SEIFENLAUGE waschen.

## LUBRIFICATORI A NEBBIA D'OLIO

Serie 041E, 042E, S406E, X400E, Y400E, da

$\frac{1}{2}$ ,  $\frac{3}{4}$ ,  $\frac{1}{2}$ ,  $\frac{3}{4}$ ,  $1$ ,  $1\frac{1}{2}$  und  $1\frac{1}{2}$ .

Serie 039E, 040E, da  $\frac{1}{2}$  und  $\frac{3}{4}$ .

Serie 10-026, da 2".

## CALOTTA TRASPARENTE

Pressione max.: 10,5 kg/cm<sup>2</sup>.

Temperatura max.: 50°C.

## CALOTTA METALLICA

Pressione max.: 18 kg/cm<sup>2</sup> (X400E, Y400E e 10-026,

10,5 kg/cm<sup>2</sup>.)

Temperatura max.: 80°C.

## MONTAGGIO

Montare il lubrificatore in prossimità del componente da servire, a valle del filtro e dei regolatori. Le frecce sul collare, visibili attraverso il vetro d'ispezione (1) indicano la direzione del flusso dell'aria. Per invertire quest'ultimo, togliere il tappo di testa (2) ed il premistoppa (3) indi girare il tubo di Venturi (4) di 180° usando un cacciavite. (Il

gruppo della serie 10-026 non è reversibile. Direzione del flusso: da sinistra a destra, esclusivamente). Un lubrificatore può servire due congegni (max.) Montare il minor numero possibile di valvole, gomiti e connessioni tra il gruppo ed il componente suaccennato. Rabboccare con olio attraverso il tappo (5), senza escludere la pressione dell'aria.

Nota: Se viene impiegato un tipo d'olio contenente sostanze solubili o additivi (grafite o bisolfuro di molibdeno), togliere il dischetto di feltro (6) ed accertarsi che, al momento in cui si rimonta, il cono (maschio) del disco di pressione (9) sia rivolto verso il baso.

**Norme per il lubrificante.** Richiedere la distinta dei tipi di olio raccomandata. Si consiglia di consultare il costruttore del dispositivo da lubrificare per definire il tipo d'olio più adatto. Si sconsiglia l'impiego d'olio contenenti preparati quali saponi, riempitivi, ecc.

## FUNZIONAMENTO

Per effettuare la regolazione, allentare il dado zigrinato (7) chiudere a fondo lo spillo (8) inserire l'aria indi aprire lo spillo fino a rilevare il giusto flusso d'olio attraverso il vetro d'ispezione (circa 1 goccia d'olio ogni 0,28 m<sup>3</sup>/min). A regolazione avvenuta, serrare il dado zigrinato.

Nota: I gruppi della serie 10-026 posseggono un coperchio di sicurezza; questo deve venir tolto prima di apportare eventuali regolazioni. Se occorre un tubo di venturi, inserirlo dalle aperture di entrata o di uscita, indi allineare i fori per inserirvi lo stelo sul tubo di venturi. Pulire le calotte di plastica **ESCLUSIVAMENTE CON ACQUA INSAPONATA.**

## LUBRICADORES "OIL-FOG"

### (ACEITE NEBULIZADO)

Serie 041E, 042E, S406E, X400E, Y400E para

tuberías de  $\frac{1}{2}$ ,  $\frac{3}{4}$ ,  $\frac{1}{2}$ ,  $\frac{3}{4}$ ,  $1$ ,  $1\frac{1}{2}$  y  $1\frac{1}{2}$  gas.

Serie 039E, 040E, de  $\frac{1}{2}$  y  $\frac{3}{4}$  gas.

Serie 10-026, de 2" gas.

### DEPOSITO TRANSPARENTE

Presión máxima: 10,5 kg/cm<sup>2</sup>.

Temperatura máxima: 50°C.

### DEPOSITO METALICO

Presión máxima: 18 kg/cm<sup>2</sup> (X400E, Y400E y

10-026, 10,5 kg/cm<sup>2</sup>.)

Temperatura máxima: 80°C.

## INSTALACION

Instalar cerca del mecanismo que se vaya a servir, después del filtro y reguladores. Las flechas que se ven en el collar por el tubo visual (1) indican la dirección de la corriente de aire. Para invertir la dirección de la corriente, quitar el tapón superior (2) y la válvula goteadora (3) y girar el tubo venturi (4) 180° con un destornillador. (El aparato Serie 10-026 no es reversible, siendo la dirección del caudal de izquierda a derecha únicamente). Se recomienda un lubricador por cada dos aparatos (como máximo). Mantener al mínimo el número de válvulas, codos y juntas entre la unidad y los aparatos que se vayan a lubricar. Llenar con aceite por el tapón de llenado (5) (se puede hacer con la presión de aire conectada ("ON").

Nota: Si se usa aceite sulfonado o con aditivo químico (grafito o disulfuro de molibdeno) quitar el disco de fieltro (6) asegurándose de que el cono macho del disco de presión (9) queda con la cara hacia abajo al volver a montarlo.

**Especificación de Lubricantes.** Tenemos disponible una lista de aceites recomendados. Lo preferible es consultar al fabricante del aparato que se vaya a lubricar acerca del aceite más adecuado. Aceites compuestos que contengan jabón, etc., no son recomendables.

## OPERACION

Para ajustar, aljorar la tuerca moleteada (7), cerrar la aguja (8) completamente, abrir el aire y abrir la aguja hasta que se vea el flujo de aceite necesario por el tubo visual. (Se necesita aproximadamente 1 gota de aceite por cada 283 lts. por minuto.) Apretar la tuerca moleteada después del ajuste.

## NOTA

Nota: Los aparatos Serie 10-026 van provistos cada uno de una tapa de seguridad contra la intervención ajena, la cual se debe retirar para fines de ajuste.

Si se necesita un casquillo venturi, insertarlo por la lumbrera de entrada o salida y alinear los orificios para recibir el vástago sobre el tubo venturi.

Para lavar los depósitos plásticos, emplear **UNICAMENTE AGUA JABONOSA.**

## DIMSMÖRJAPPARATER

Typ 041E, 042E, S406E, X400E, Y400E med

$\frac{1}{2}$ ,  $\frac{3}{4}$ ,  $\frac{1}{2}$ ,  $\frac{3}{4}$ ,  $1$ ,  $1\frac{1}{2}$  eller  $1\frac{1}{2}$  anslutning.

Typ 039E, 040E med  $\frac{1}{2}$  eller  $\frac{3}{4}$  anslutning.

Typ 10-026 med 2" anslutning.

### GENOMSYNLIG BEHÅLLARE:

Max. tryck: 10,5 kg/cm<sup>2</sup>. Max. temperatur: 50°C.

### METALLBEHÅLLARE:

Max. tryck: 18 kg/cm<sup>2</sup> (X400E, Y400E och 10-026, 10,5 kg/cm<sup>2</sup>.)

Max. temperatur: 80°C.

## INSTALLATION

Apparaten monteras nära intill den betjänade anläggningen och efter filter och regulatorer i ledningen. Pilarna på kragen, som kan ses genom kontrollglaset (1), visar strömningsriktningen. Vid omskastning av strömningsriktningen skall toppmuttern (2) och droppmunstycket (3) tas av, varefter venturin (4) vrids 180° med en skruvmejsel. (Aggregaten i serie 10-026 är inte vändbara. Strömningsriktningen är enbart från vänster till höger). En smörjapparat bör användas för högst två anläggningar. Håll ventiler, knäror och rörförbindningar vid ett minimum mellan apparaten och de smorda anläggningarna. Fyll på olja genom pluggen (5), vilket kan ske med tryckluften på.

Obs! Vid användning av olja är löslig eller additiv typ (med tillsats av grafit eller molybdendisulfid) skall filtpackningen (6) tas bort, varvid tillses att konan på tryckplattan (9) pekar nedåt vid hopsättningen.

**Öfverrekommendationer.** En förteckning över rekommenderade smörjolja kan erhållas. Helst bör tillverkaren av den smorda anläggningen rådfrågas. Sammansatta oljor innehållande tvål, fyllmedel o.s.v. rekommenderas ej.

## DRIFT

Vid inställning skall den räfflade låsmuttern (7) lossas och nålen (8) stängas helt, varefter tryckluften åter släpps på och nålen öppnas, tills önskat oljeflöde kan ses genom kontrollglaset (ca 1 droppe olja på 280 dm<sup>3</sup>). Drag till den räfflade låsmuttern efter inställningen.

Obs! Aggregat i serie 10-026 är försedda med kläffingerskyddat lock. Detta måste tas av innan justering kan utföras.

Om en venturibusning erfordras, skall den införas från inlopps- eller utloppsmynningen. Rikta upp halen för att mota venturins skaff. Behållare av plast skall tvättas **ENBART I TVÄLVATTEN.**

## MANUAL AND AUTOMATIC- DRAIN FILTERS

Series F01,  $\frac{1}{4}$ " and  $\frac{3}{8}$ " sizes.  
Series F02,  $\frac{1}{4}$ ",  $\frac{3}{8}$ ",  $\frac{1}{2}$ " and  $\frac{3}{4}$ " sizes.  
Series 30BE and 30CG,  $\frac{3}{4}$ ", 1", 1 $\frac{1}{4}$ " and 1 $\frac{1}{2}$ " sizes.  
Series 12-063, 1 $\frac{1}{4}$ ", 1 $\frac{1}{2}$ " and 2" sizes.

TRANSPARENT BOWL  
Max. Pressure: 150 p.s.i. Max. Temp. 120°F.  
METAL BOWL  
Max. Pressure: 250 p.s.i. Max. Temp. 175°F.

### INSTALLATION

Install near to components being served but upstream from regulators, air line lubricators, etc. The arrow on the body or port markings indicate direction of air flow. Connect a short straight drain pipe to the  $\frac{1}{8}$ " female pipe thread at the bottom of the Automatic-Drain Filters.

### OPERATION

On Automatic-Drain Filters no adjustments are necessary. On manual filters, drain bowl regularly—before moisture level reaches baffle. Clean filter elements and, on automatic-drain models, monel screen regularly. If required, automatic-drain models can be manually tripped by pushing a thin rod up through the bottom of the automatic-drain mechanism to completely purge the bowl.

To remove filter element, shut off air supply, bleed off pressure from unit and proceed as follows:

#### 12-063

Unscrew intermediate body, remove wing nut and detach louvre by twisting if necessary. Change filter element when necessary. Do not clean.

#### 30BE, 30CG

Remove clamp ring screw and nut and ease the latched clamp ring segments apart (rotate intermediate body slightly and force upwards to release lock). Do not use a lever to force the two halves apart. Unscrew the deflector assembly and extract the filter element.

#### F01, F02

Unscrew the bowl anti-clockwise. Unscrew the baffle and withdraw the element and filter shield from filter guide.

To clean filter element, wash in paraffin and blow out thoroughly with compressed air.

To clean plastic bowls wash in SOAPY WATER ONLY.

### HANDBEDIENDE EN AUTOMATISCHE AFTAPINRICHTINGEN

Serie F01, voor de maten  $\frac{1}{4}$ " en  $\frac{3}{8}$ "

Serie F02, voor de maten  $\frac{1}{4}$ ",  $\frac{3}{8}$ ",  $\frac{1}{2}$ " en  $\frac{3}{4}$ "

Series 30BE en 30CG, voor de maten  $\frac{3}{4}$ ", 1", 1 $\frac{1}{4}$ ", 1 $\frac{1}{2}$ "

Serie 12-063, voor de maten 1 $\frac{1}{4}$ ", 1 $\frac{1}{2}$ ", 2"

#### DOORZICHTIG RESERVOIR

Max. druk: 10,5 at. Max. temperatuur: 50°C

#### METALEN RESERVOIR

Max. druk: 18 at. Max. temperatuur: 80°C

#### INSTALLATIE

Te monteren in nabijheid van te bedienen apparaat maar vóór regulatoren, nevelsmeer-apparaten enz. De pijl op het huis of de poortmerktekens geven de juiste richting van de luchtstroom aan. Verbind een korte rechte afvoerpijp met de  $\frac{1}{8}$ " inwendige schoefdraad aan de onderkant van de filters met automatische afvoer.

#### BEDIENING

Automatisch—geen afstelling is nodig. Modellen met handafvoer, tap het reservoir regelmatig af voordat het vloeistof-niveau de keerplaat bereikt. Reinig het filterelement en—bij modellen met automatische afvoer—de monelmetalen zeef regelmatig. Desgewenst kunnen modellen met automatische afvoer met de hand worden uitgeschakeld door een dunne staaf door de onderkant van het automatische afvoermecanisme omhoog te duwen om het reservoir geheel te zuiveren.

Alvorens het filter te verwijderen, sluit de luchttoevoer af, laat de druk ontsnappen en voer de volgende werkzaamheden uit:

#### 12-063

Schroef het tussenstuk uit, verwijder de vleugelmoer en verwijder de schoepenring, desnoods wringen. Vernieuw zonodig de filterpatroon. Dit geldt niet voor een gesinterd bronzen filterpatroon, die moet worden schoongemaakt in petroleum en daarna doorgeblazen.

#### 30BE, 30CG

Alvorens te demonteren, luchttoevoer afsluiten; verwijder de klemringschoef en moer en haal de gekoppelde klemringonderdelen uit elkaar. Draai het tussenstuk een weinig (daarbij een opwaartse druk uitoefenend om vrij te maken). Gebruik geen hefboom om beide helften uiteen te wrikken. Schroef de schoepenring los en neem de filterpatroon uit.

#### F01, F02

Om het filterelement te verwijderen moet men de luchttoevoer afsluiten en het reservoir linksom losschroeven. Schroef de keerplaat los en neem het element en het filterscherm uit de filtergeleider. Reinig het filterelement in petroleum en blaas daarna goed met perslucht door. Een plastic kolf mag ALLEEN MET ZEEPWATER worden gereinigd.

### VIDANGE MANUELLE ET AUTOMATIQUE

Série F01, de  $\frac{1}{4}$ " et  $\frac{3}{8}$ "

Série F02, de  $\frac{1}{4}$ ",  $\frac{3}{8}$ ",  $\frac{1}{2}$ " et  $\frac{3}{4}$ "

Séries 30BE et 30CG, de  $\frac{3}{4}$ ", 1", 1 $\frac{1}{4}$ " et 1 $\frac{1}{2}$ "

Série 12-063, de 1 $\frac{1}{4}$ ", 1 $\frac{1}{2}$ " et 2"

#### CUVE TRANSPARENTE

Pression max.: 10,5 kg/cm<sup>2</sup>

Température max.: 50°C

#### CUVE METALLIQUE

Pression max.: 18 kg/cm<sup>2</sup>

Température max.: 80°C

#### MONTAGE

Monter à proximité des appareils à desservir mais en amont des régulateurs, huileurs de conduite d'air, etc. La flèche sur le corps de l'appareil ou les repères aux orifices indiquent le sens de la circulation d'air. Raccorder un tuyau de vidange court et droit au filetage intérieur de  $\frac{1}{8}$ " au bas des filtres à vidange automatique.

#### FONCTIONNEMENT

Automatique—aucun réglage à faire. Types à vidange manuelle, purger la cuve régulièrement—avant que le niveau des condensats atteigne la chicane. Nettoyer régulièrement l'élément filtrant et, sur les modèles à vidange automatique, l'écran en monel. Si besoin est, on peut actionner à la main les modèles à vidange automatique en introduisant une tige mince par le bas du mécanisme de vidange automatique et en la faisant remonter afin de purger complètement la cuve.

Pour démonter l'élément filtrant, fermer l'arrivée d'air, vider l'appareil de toute pression et procéder comme suit:

#### 12-063

Dévisser le corps intermédiaire, enlever l'écrou-papillon et détacher le déflecteur, en le tournant au besoin. Changer l'élément filtrant quand besoin est. Ne pas le nettoyer ni le laver (filtre en carton special).

#### 30BE, 30CG

Fermer l'air sous pression; enlever la vis et l'écrou du collier de serrage et séparer les segments de ce dernier (faire tourner légèrement le corps intermédiaire et forcer vers le haut pour dégager l'encliquetage des segments). Ne pas forcer avec un levier pour séparer les deux moitiés. Dévisser l'ensemble déflecteur et extraire l'élément filtrant.

#### F01, F02

Fermer l'air sous pression et dévisser la cuve dans le sens contraire aux aiguilles d'une montre. Dévisser la chicane et retirer l'élément et le protège-filtre du guide-filtre.

Pour nettoyer l'élément filtrant, le laver dans du pétrole et bien le souffler à l'air comprimé.

Pour laver les cuves en plastique, employer UNIQUEMENT DE L'EAU SAVONNEUSE.

## MANUELLER UND AUTOMATISCHER ABLAUSSMECHANISMUS

Serie F01, Rohranschluss  $R_{1\frac{1}{2}}$  und  $R_1$   
Serie F02, Rohranschluss  $R_{1\frac{1}{2}}$ ,  $R_1$ ,  $R_{\frac{3}{4}}$  und  $R_{\frac{1}{2}}$   
Serie 30BE und 30CG, Rohranschluss  $R_{1\frac{1}{2}}$ ,  $R_1$ ,  $R_{1\frac{1}{4}}$   
und  $R_{1\frac{1}{2}}$   
Serie 12-063, Rohranschluss  $R_{1\frac{1}{2}}$ ,  $R_1$  und  $R_2$   
Betriebsdruck:  
Bis 10,5 kp/cm<sup>2</sup> mit Kunststoffbehälter  
Bis 18 kp/cm<sup>2</sup> mit Metallbehälter  
Temperaturbereich:  
bis 50°C mit Kunststoffbehälter  
Bis 80°C mit Metallbehälter

## Einbau

Nahe der Verbrauchsstelle, jedoch vor allen Druckreglern, Nebelöfern usw. einbauen. Richtungspfeile auf dem Gehäuse oder an den Öffnungen zeigen die korrekte Richtung des Luftstromes an. Eine kurze gerade Ablaufleitung an das 3,2-mm-Rohrinnengewinde unten an Filtern mit automatischer Entwässerung anbringen.

## Betrieb

Automatische Modelle—keine Einstellungen notwendig. Modelle mit Handentwässerung, der Behälter ist regelmässig und bevor die Flüssigkeit bis zur Trennkappe reicht, zu entleeren. Filtereinsatz und—bei automatischen Modellen—Monelsieb sind regelmässig zu reinigen. Auf Wunsch können Modelle mit automatischer Entwässerung auch handbetätigt werden, indem man eine dünne Stange durch den Boden des Mechanismus zur automatischen Entwässerung schiebt, um den Behälter vollkommen zu reinigen.

Zum Ausbau des Filtereinsatzes, wird die Luft abgestellt und der Filter entlüftet, und wie folgt vorgehen:

### 12-063

Werden das Zwischenstück und die Flügelmutter ausgeschraubt und der Drällkörper abgenommen, wenn erforderlich, durch Verdrehen, Filtereinsatz, wenn nötig, erneuern. Nicht reinigen.

### 30BE, 30CG

Zum Zerlegen wird der Luftdruck abgestellt, die Klemmingschraube samt Mutter entfernt und die verspannten Segmente des Klemmrings durch leichtes Drehen des Zwischengehäuses und Aufwärtsdrücken zum Lösen der Sperre gelockert. Die beiden Hälften dürfen nicht durch Hebelwirkung voneinander getrennt werden. Der Drällkörper einschliesslich O-Ring und Dralling wird herausgeschraubt und der Filtereinsatz herausgenommen.

### F01, F02

Zum Ausbau des Filtereinsatzes wird die Druckluft abgestellt und der Behälter links herum abgeschraubt. Ablenkplatte ausschrauben und den Filtereinsatz und Filtersieb aus Filterführung herausnehmen.

Reinigen des Filtereinsatzes erfolgt durch Spülen in Paraffin, danach gründlich mit Druckluft ausblasen. Kunststoffbehälter NUR IN SEIFENLAUGE waschen.

## SPURGO MANUALE E AUTOMATICO

Serie F01, da  $\frac{1}{2}$ " e  $\frac{3}{8}$ "  
Serie F02, da  $\frac{1}{2}$ ",  $\frac{3}{8}$ ",  $\frac{1}{2}$ " e  $\frac{3}{4}$ "  
Serie 30BE e 30CG, da  $\frac{1}{2}$ ", 1",  $1\frac{1}{4}$ " e  $1\frac{1}{2}$ "  
Serie 12-063, da  $1\frac{1}{2}$ ",  $1\frac{1}{4}$ " e 2"

### CALOTTA TRASPARENTE

Pressione max.: 10,5 kg/cm<sup>2</sup>.  
Temperatura max.: 50°C.

### CALOTTA METALICA

Pressione max.: 18 kg/cm<sup>2</sup>.  
Temperatura max.: 80°C.

### MONTAGGIO

Montare il filtro in prossimità del componente da servire, a monte dei regolatori, dei lubrificatori della linea dell'aria, ecc. La freccia presente sul corpo o i contrassegni sulle aperture indicano la direzione del flusso d'aria. Collegare una sezione corta e dritta di tubo di scarico al filetto da  $\frac{1}{8}$ " situato al fondo dei filtri autoscaricanti.

## FUNZIONAMENTO

Modelli automatici—non occorrono regolazioni. Modelli a scarico manuale—scolare la calotta regolarmente—prima che la condensa di vaporizzazione raggiunga il livello del deflettore. Pulire l'elemento del filtro, per i modelli autoscaricanti, la reticella di monel regolarmente. Se necessario, i modelli autoscaricanti, possono venir fatti scattare a mano, spingendo un'astina sottile attraverso il fondo del meccanismo per lo scarico automatico, onde spurgare la calotta completamente.

Per smontare l'elemento del filtro, escludere l'alimentazione dell'aria e lasciar scaricare la pressione dal gruppo, e proseguire nel modo seguente:

### 12-063

Svitare il corpo intermedio, togliere il dado ad alette ed estrarre la protezione a persiana torcendola, se necessario. Non si pulisca, ma si sostituisca l'elemento quando necessario.

### 30BE, 30CG

Escludere la pressione dell'aria, togliere la vite ed il dado della ghiera, allentarne ed allontanarne i segmenti (far girare il corpo intermedio, leggermente e spingerlo in alto per liberarlo). Non si usi una leva per separare i due semicorpi. Smontare, svitandolo, il gruppo del deflettore suddetto ed estrarre l'elemento del filtro.

### F01, F02

Escludere la pressione dell'aria e svitare la calotta, girandola in senso antiorario. Svitare il deflettore indi togliere elemento e schermo del filtro dalla guida.

Lavare l'elemento del filtro in modo analogo ed asciugarlo accuratamente con un getto d'aria.

Lavare le calotte di plastica ESCLUSIVAMENTE CON ACQUA INSAPONATA.

## PURGA MANUALE E AUTOMATICA

Serie F01, de  $\frac{1}{2}$ " y  $\frac{3}{8}$ "  
Serie F02, de  $\frac{1}{2}$ ",  $\frac{3}{8}$ ",  $\frac{1}{2}$ " y  $\frac{3}{4}$ "  
Serie 30BE y 30CG, de 1", 1 $\frac{1}{4}$ " y 1 $\frac{1}{2}$ "  
Serie 12-063, de 1 $\frac{1}{2}$ ", 1 $\frac{1}{4}$ " e 2"

### DEPOSITO TRASPARENTE

Presión máxima: 10,5 kg/cm<sup>2</sup>.  
Temperatura máxima: 50°C.

### DEPOSITO METALICO

Presión máxima: 18 kg/cm<sup>2</sup>.  
Temperatura máxima: 80°C.

### INSTALACION

Instalar cerca de los aparatos que se vayan a servir, pero antes de reguladores, lubricadores de tubería de aire comprimido, etc. La flecha grabada en el cuerpo o las marcas en las lumbreras indican el sentido de flujo del aire. Enrosacar un tubo de purga corto y recto en la rosca hembra de  $\frac{1}{8}$ " que se encuentra en el fondo de los filtros de purga automática.

### OPERACION

Automática—no se necesitan ajustes. Versiones de purga manual, purgar el depósito regularmente—antes de que el nivel de humedad llegue al desviador. Limpiar regularmente el elemento filtrante y, en modelos automáticos, la pantalla de metal monel. En caso necesario, los modelos de purga automática se pueden inmovilizar introduciendo una varilla delgada desde el fondo del mecanismo de purga automática, a fin de purgar completamente el depósito.

Para desmontar el elemento filtrante, cerrar el suministro de aire, purgar la presión y proceder del modo siguiente:

### 12-063

Desenroscar el cuerpo intermedio, quitar la tuerca de palomilla y separar la repilla retorciéndola si es

preciso. Cambiar el elemento filtrante cuando sea necesario. No limpiarlo.

### 30BE, 30CG

Cerrar la presión de aire; quitar la tuerca y tornillo del anillo abrazadera y separar los segmentos unidos (girar el cuerpo intermedio ligeramente y forzar hacia arriba para soltar el cierre). No apalancar para separar ambas mitades. Desenroscar el conjunto del deflector y extraer el elemento filtrante.

### F01, F02

Cerrar la presión de aire y desenroscar el depósito dando vueltas hacia la izquierda. Desenroscar el deflector y separar de la guía el elemento y el protector del filtro.

Para limpiar el elemento filtrante, lavarlo con parafina y secarlo bien con aire comprimido.

Para lavar los depósitos, emplear ÚNICAMENTE AGUA JABONOSA.

## MANUELL OCH AUTOMATISK TOMNING

Typ F01, med  $\frac{1}{2}$ " eller  $\frac{3}{8}$ " anslutning.  
Typ F02, med  $\frac{1}{2}$ ",  $\frac{3}{8}$ ",  $\frac{1}{2}$ " eller  $\frac{3}{4}$ " anslutning.  
Typ 30BE, och 30CG med  $\frac{1}{2}$ ", 1",  $1\frac{1}{4}$ " eller  $1\frac{1}{2}$ " anslutning.  
Typ 12-063, med  $1\frac{1}{2}$ ",  $1\frac{1}{4}$ " eller 2" anslutning.  
GENOMSYNLIG BEHÅLLARE  
Max. tryck: 10,5 kg/cm<sup>2</sup>. Max. temperatur: 50°C.  
METALLBEHÅLLARE  
Max. tryck: 18 kg/cm<sup>2</sup>. Max. temperatur: 80°C.  
INSTALLATION

Filtret monteras nära intill den betjänade anläggningen men före eventuella regulatorer, luftsmörjapparater o.s.v. i ledningen. Pilen på huven eller markeringar på öppningarna visar luftströmnings riktning. Anslut ett kort, rakt avtappningsrör till den  $\frac{1}{8}$ " innergången nedtill på filter med automatisk avtappning.

### GRIFT

Automatisk—inga justeringar behövliga. Manuella avtappningstyper. Tom behållaren regelbundet och innan fuktighetsnivån nar skiljeplaten. Rengör filterelementet och ifråga om automatiska modeller monelskärmen regelbundet. Vid behov kan automatiska modeller utlösas, genom att man skjuter upp en small stång genom botten på avtappningsmekanismen, så att behållaren tömms helt och hållet.

Vid borttagning av filterelementet: Då filterelementet skall avlägsnas, stäng av tryckluftstillförseln, avlufta aggregatet och förfar sedan på följande sätt

### 12-063

Skriva av mellanhuset, tag av vingmuttern och lösgör deflektorn genom att vid behov vrida den. Byt ut filterelementet vid behov. Rengör det inte.

### 30BE, 30CG

Skall tryckluften först stängas av. Tag bort fastringens skruv och mutter och skilj försiktigt fastringens bägge delar åt (vrid lätt på mellanhuset och tryck det uppåt för att lossa på fastringen). Använd inte någon hävstång för att skilja de båda halvorna åt. Skruva av deflektoraggregatet och drag ut filterelementet.

### F01, F02

Skall tryckluften stängas av, varefter behållaren skruvas loss moturs. Skruva bort skiljeplåten samt drag ut elementet och filterskärmen ur filterstyrningen.

Filterelementet rengörs genom att sköljas i fotogen och blåsas ut noga med tryckluft.

Behållaren av plast skall tvättas ENBART I TVÄLVATTEN.

The Norgren *Citation* Line  
offers a NEW STANDARD in Compressed Air Filtration

# Standard Filter

1/4" - 3/4" • WITH INTERCHANGEABLE  
MANUAL OR AUTOMATIC DRAIN

## SPECIFICATIONS

PIPE SIZES: 1/4", 3/8", 1/2", 3/4" B.S.P. Taper

BOWLS: 1/3 PT (0.20 litres) SAFETY CLEAR  
TRANSPARENT (STANDARD)  
METAL (OPTIONAL)

FILTER ELEMENTS:

50 MICRON SINTERED BRONZE  
(STANDARD)

5 AND 25 MICRON SINTERED BRONZE  
(OPTIONAL)

MAXIMUM PRESSURE:

Transparent Bowl: 150 psi (10.5 Kg/cm<sup>2</sup>)

Metal Bowl: 250 psi (18 Kg/cm<sup>2</sup>)

MAXIMUM TEMPERATURE:

Transparent Bowl: 120°F (50°C)

Metal Bowl: 175°F (80°C)

AUTOMATIC OR MANUAL DRAIN

MOUNTING HOLES: 3/16" (7 mm)

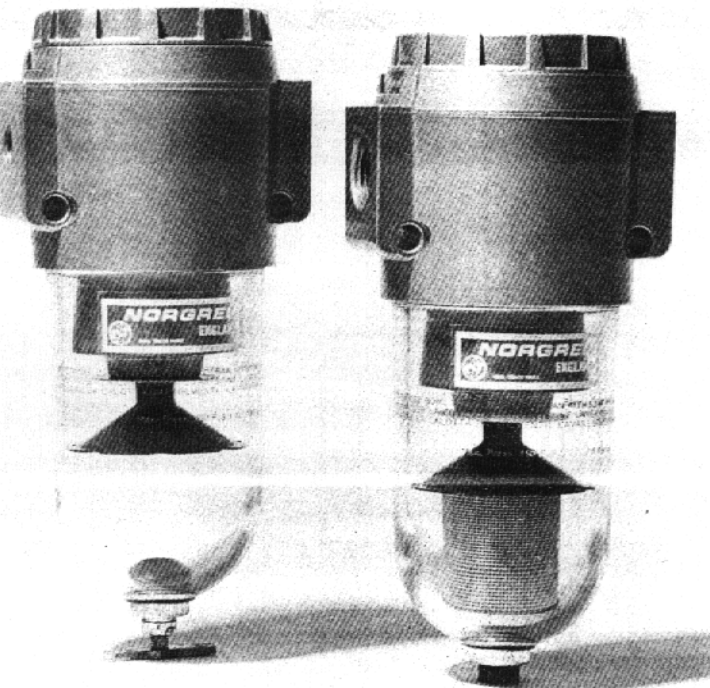

## FEATURES

**A.** Interchangeable automatic drain or manual drain.

**B.** Threaded bowl is easily removed - no clamp ring.

**C.** Safety-Clear, non shattering, transparent bowl.

**D.** Plastic insert with draincock reduces internal stress.

**E.** Built in mounting provision.

**F.** This filter removes more water than any competitive filter on the market today.

**G.** Large filter element minimises pressure drop.

**H.** Automatic - Drain operates under FLOW and NO FLOW conditions.

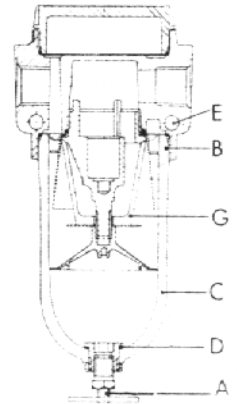

Manual-Drain Models

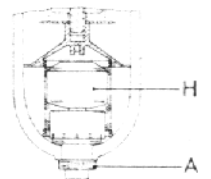

Automatic-Drain Models

## WHERE TO USE

The FO2 filter is designed for general application on air and non-corrosive gas systems where effective filtration is required.

**NORGREN**

SHIPSTON-ON-STOUR, WARWICKSHIRE, ENGLAND





## OPERATION

Air flows through the directional louvres (A) forcing it into whirling flow pattern. Liquid particles are thrown against the inside wall of the bowl by centrifugal force. The liquid particles run down into the bottom of the bowl. The baffle (B) maintains a "quiet zone" in the lower part of the bowl to prevent air turbulence from picking up the liquid and returning it to the air stream. The air then passes through the filter element (C) to remove solid contaminants.

Liquid contaminants are drained by opening the manual drain-cock (D).

Alternatively, an automatic drain assembly, easily interchangeable with the manual drain, automatically dumps liquid as it collects. When the liquid level in the bowl reaches a predetermined height the float (E) opens a pilot valve (F). This admits air above the piston (G), thus causing the drain valve (H) to open. The liquid is expelled by air pressure to a drain where-upon the float closes the pilot valve and so the drain valve.

The mechanism is designed to open when no air pressure is in the line permitting overnight draining. It is a sealed unit.

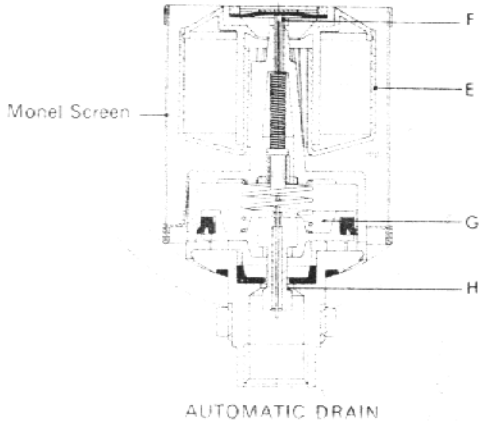
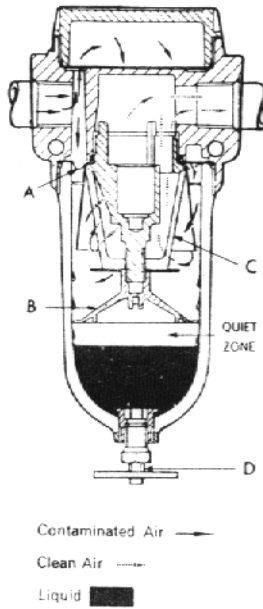

## AUTO-DRAIN KITS

FO2 Filters can be quickly converted from manual to automatic-draining types. Order appropriate Auto-Drain Kit listed in accessories table and follow these easy assembly steps:—

- 1 Remove bowl, unscrew draincock and retaining ring and remove bowl insert.



- 2 Place automatic-drain mechanism in bowl.



- 3 Screw up retaining ring on external thread of automatic-drain mechanism.

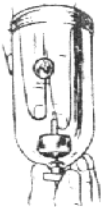

- 4 Position protective monel screen (open end upwards) and float.



- 5 Screw back bowl into body.

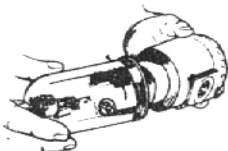

## DIMENSIONS

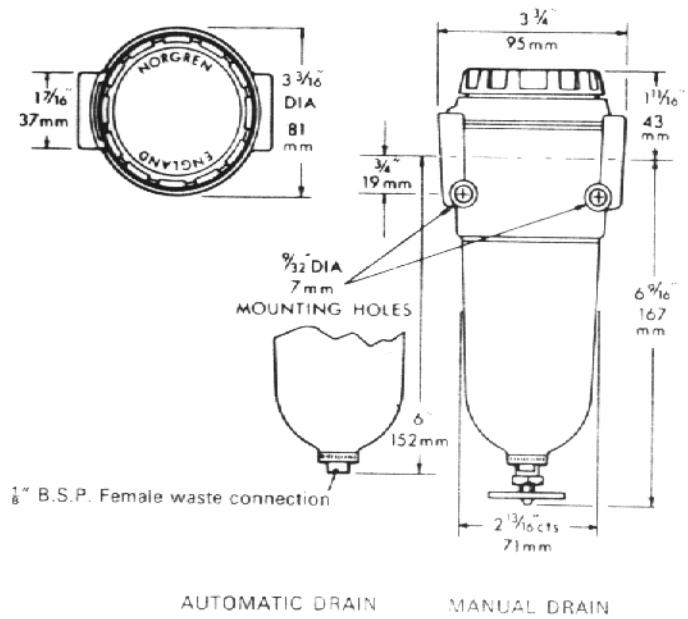

## MOUNTING DIMENSIONS

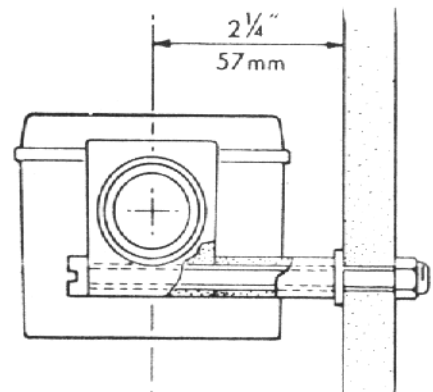

## PERFORMANCE CHARACTERISTICS

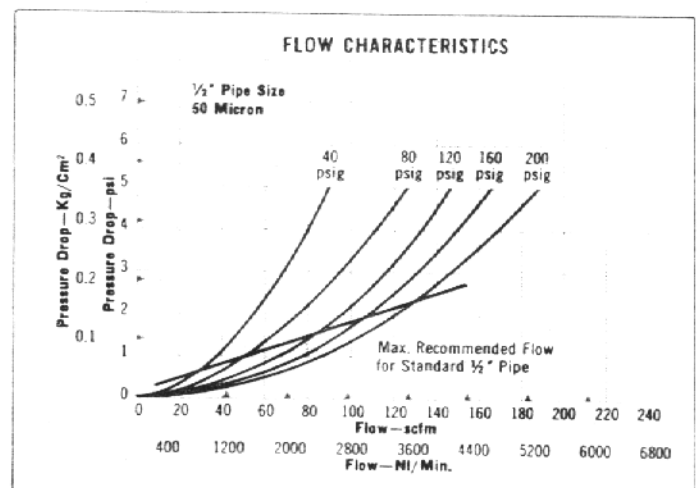

## ORDER TABLE



BOWL TYPE	DRAIN TYPE	† PIPE SIZE	STANDARD	OPTIONAL MODELS	
			FILTER ELEMENT		
			50-MICRON	25-MICRON	5-MICRON
SAFETY-CLEAR	AUTOMATIC	1/4"	<b>FO2-200-A3TB</b>	FO2-200-A2TB	FO2-200-A1TB
		3/8"	<b>FO2-300-A3TB</b>	FO2-300-A2TB	FO2-300-A1TB
		1/2"	<b>FO2-400-A3TB</b>	FO2-400-A2TB	FO2-400-A1TB
		* 3/4"	<b>FO2-600-A3TB</b>	FO2-600-A2TB	FO2-400-A1TB
	MANUAL	1/4"	<b>FO2-200-M3TB</b>	FO2-200-M2TB	FO2-200-M1TB
		3/8"	<b>FO2-300-M3TB</b>	FO2-300-M2TB	FO2-300-M1TB
		1/2"	<b>FO2-400-M3TB</b>	FO2-400-M2TB	FO2-400-M1TB
		* 3/4"	<b>FO2-600-M3TB</b>	FO2-600-M2TB	FO2-600-M1TB

OPTIONAL MODELS					
BOWL TYPE	DRAIN TYPE	† PIPE SIZE	50-MICRON	25-MICRON	5-MICRON
METAL	AUTOMATIC	1/4"	FO2-200-A3MB	FO2-200-A2MB	FO2-200-A1MB
		3/8"	FO2-300-A3MB	FO2-300-A2MB	FO2-300-A1MB
		1/2"	FO2-400-A3MB	FO2-400-A2MB	FO2-400-A1MB
		* 3/4"	FO2-600-A3MB	FO2-600-A2MB	FO2-600-A1MB
	MANUAL	1/4"	FO2-200-M3MB	FO2-200-M2MB	FO2-200-M1MB
		3/8"	FO2-300-M3MB	FO2-300-M2MB	FO2-300-M1MB
		1/2"	FO2-400-M3MB	FO2-400-M2MB	FO2-400-M1MB
		* 3/4"	FO2-600-M3MB	FO2-600-M2MB	FO2-600-M1MB

\* 3/4" Models are 1/2" units tapped 3/4" for use with 3/4" o.d. copper pipe fittings.

† Standard pipe threads are B.S.P. Taper.  
Alternative pipe threads B.S.P. Parallel and ANPT must be specified.

## ACCESSORIES

	<p><b>BOWL GUARD KIT</b> (includes special transparent bowl) Perforated metal gives positive protection yet allows visibility of bowl contents.</p>	<p>For Manual Drain Models 18-012-986 For Automatic-Drain Models 18-012-987</p>
	<p><b>MOUNTING KIT</b> Consists of metal and wood screws, spacer tubes, washers and self locking nuts. Fits built-in mounting holes.</p>	<p>18-026-999 (W 7)</p>
	<p><b>AUTO-DRAIN KITS</b> For simple conversion from manual to automatic-drain. For Transparent Bowl Models For Metal Bowl Models</p>	<p>3000-01 3000-99</p>

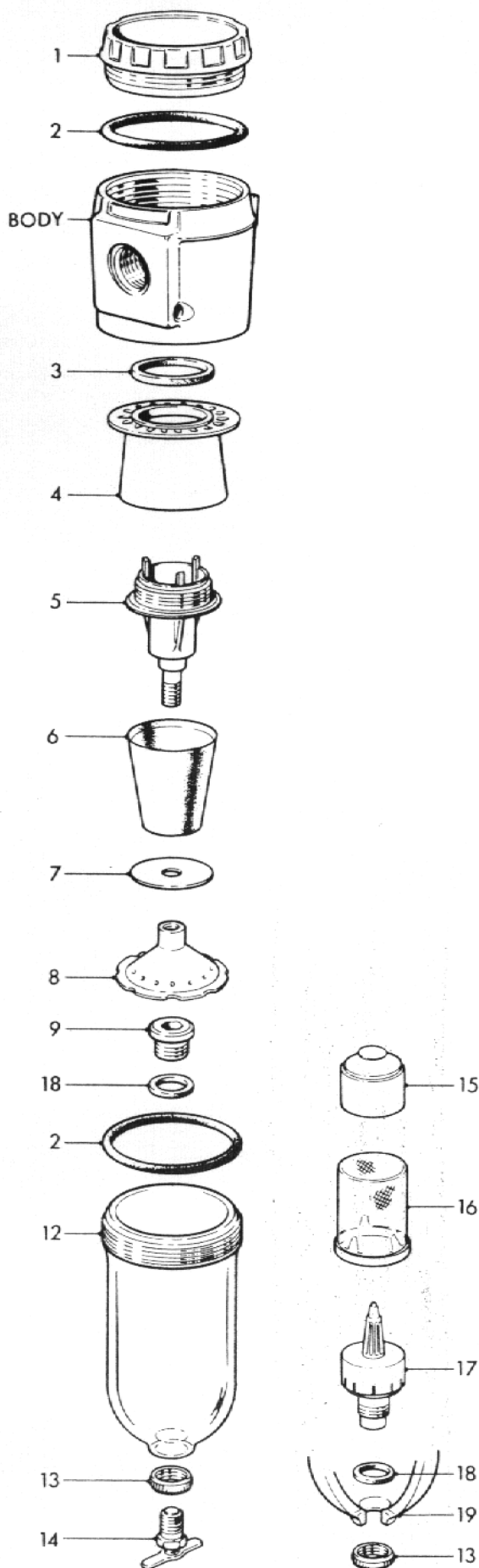

MANUAL DRAIN      AUTOMATIC DRAIN

**NORGREN**

SHIPSTON-ON-STOUR, WARWICKSHIRE, ENGLAND

EINC-101 7/68 ©

## MAINTENANCE

To remove the filter element, shut off air pressure and unscrew the bowl anti-clockwise (12, 19). Unscrew the baffle (8) and withdraw the element and filter shield (6, 7) from filter guide (5). To clean filter element, wash in paraffin and blow out thoroughly with compressed air. Keep filter clean for best performance and minimum pressure drop. Remove the monel screen (16) from the bowl of automatic-drain models and blow out with compressed air.

Clean TRANSPARENT BOWLS in soapy water. DO NOT USE SOLVENTS AS THEY WILL DESTROY THE BOWL.

To completely dis-assemble remove the filter guide, which retains the deflector assembly (4) by means of a  $\frac{1}{2}$ " open wrench.

After cleaning, inspect "O" rings and gaskets for nicks and cuts. On re-assembly ensure they are not twisted and slightly smear with silicone grease. Do not crush filter element by over-tightening baffle.

On automatic-drain models, the float assembly (15) is not attached and will drop out when the bowl is turned upside down. The automatic-drain assembly (17) can be removed by loosening the knurled retaining ring (13) and withdrawing the component from the bowl. The float and automatic-drain assemblies are not repairable items. Care should be taken on re-assembly to ensure that the monel screen is installed with the internal guides at the bottom of the bowl and also that the gasket (18) is in position on the bottom of the automatic-drain assembly.

## PARTS

**Gasket Kit** ..... F02-4-GK

Comprises:

2	'O' Ring ( $2\frac{3}{4}$ " o.d.) set of 2	2315-38
3	Gasket, Filter Guide ( $1\frac{5}{8}$ " o.d.)	2382-05
18	Gasket ( $\frac{3}{4}$ " o.d.)	2811-01

**For Manual-Drain Models**

**Repair Kit** ..... F02-4-100M

Comprises:

	Gasket Kit	F02-4-GK
	Filter Element (50 micron)	2992-02
	Draincock	684-01

**For Automatic-Drain Models - Transparent Bowl**

**Repair Kit** ..... F02-4-100A

Comprises:

	Gasket Kit	F02-4-GK
6	Filter Element (50 micron)	2992-02
16	Monel Screen	2991-98

**Auto-Drain Kit** ..... 3000-01

Comprises:

15	Float	3003-50
17	Automatic-Drain Mechanism	3000-02
16	Monel Screen	2991-98
13	Retaining Ring	2797-01
18	Gasket ( $\frac{3}{4}$ " o.d.)	2811-01

**For Automatic-Drain Models - Metal Bowl**

**Repair Kit** ..... F02-4-100AM

Comprises:

	Gasket Kit	F02-4-GK
6	Filter Element (50 micron)	2992-02
16	Monel Screen	2991-99

**Auto-Drain Kit** ..... 3000-99

Comprises:

	Auto-Drain Kit	3000-01
16	with Monel Screen	2991-99
	substituted for Monel Screen	2991-98

**Further Replacement Parts**

1	Cap	2486-01
8	Baffle	2740-01
4	Deflector Assembly	2488-50
5	Filter Guide	2483-89
7	Filter Shield	3404-01
13	Retaining Ring	2797-01
6	Filter Element (50 micron)	2992-02
6	Filter Element (25 micron)	2992-03
6	Filter Element (5 micron)	2992-04

**For Manual-Drain Models**

12	Transparent Bowl Assembly including draincock	2487-51
	Metal Bowl Assembly including draincock	3047-50
9	Bowl Insert	2796-99
14	Draincock	684-01

**For Automatic-Drain Models**

19	Transparent Bowl	2487-58
	Metal Bowl	3047-01
15	Float	3003-50
17	Automatic-Drain Mechanism	3000-02
16	Monel Screen (transparent bowl)	2991-98
16	Monel Screen (metal bowl)	2991-99

WHEN ORDERING SPARES QUOTE MODEL NUMBER AND KIT OR PART DESCRIPTION

# 'E' Type Oil Fog Lubricators

$\frac{1}{4}$ " — 1" • 3 OZ.,  $\frac{1}{4}$  PT.,  $\frac{1}{3}$  PT. NOMINAL  
OIL CAPACITIES

## SPECIFICATIONS

PIPE SIZES:  $\frac{1}{4}$ ",  $\frac{3}{8}$ ",  $\frac{1}{2}$ ",  $\frac{3}{4}$ ", 1" B.S.P.T.

OIL RESERVOIRS: NOMINAL CAPACITIES

3 oz. (0.10 litres),

$\frac{1}{4}$  pt. (0.15 litres),

$\frac{1}{3}$  pt. (0.20 litres)

SAFETY CLEAR TRANSPARENT BOWLS

$\frac{1}{4}$  pt. (0.15 litres),

$\frac{1}{3}$  pt. (0.20 litres),

METAL BOWLS (Optional)

MAXIMUM PRESSURE: TRANSPARENT BOWL,

150 p.s.i. (10.5 kg/cm<sup>2</sup>)

METAL BOWL,

250 p.s.i. (18 kg/cm<sup>2</sup>)

MAXIMUM TEMPERATURE:

TRANSPARENT BOWL,

120°F (50°C)

METAL BOWL,

175°F (80°C)

MINIMUM OPERATING AIR FLOW

AT 80 p.s.i. (5.6 kg/cm<sup>2</sup>)

$\frac{1}{4}$ " : 4.5 CFM (127 litres/min)

$\frac{1}{2}$ " : 6 CFM (170 litres/min)

$\frac{3}{4}$ " : 12 CFM (340 litres/min)

1" : 18 CFM (510 litres/min)

1" : 33 CFM (850 litres/min)

MAXIMUM OPERATING AIR FLOW: ABOVE MAXIMUM  
RECOMMENDED FLOW FOR PIPE SIZE.

AIR FLOW: NORMALLY SUPPLIED FOR LEFT TO  
RIGHT AIR FLOWS \*

\* Reversible — simple adjustment permits lubricators to be  
used for air flow in either direction.

## FEATURES

- A Easily set — thumbscrew allows precise adjustment of oil feed rate.
- B Sight tube for visible oil feed. Every drop of oil seen enters the air stream.
- C Check valve — can be refilled without shutting off air supply.
- D Non-return valve in syphon tube ensures immediate lubrication when used intermittently.
- E Easy maintenance.

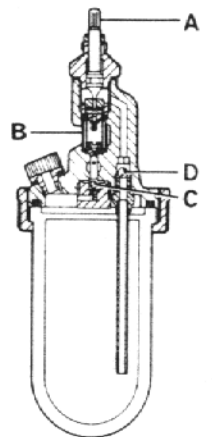

# NORGREN

SHIPSTON-ON-STOUR, WARWICKSHIRE, ENGLAND

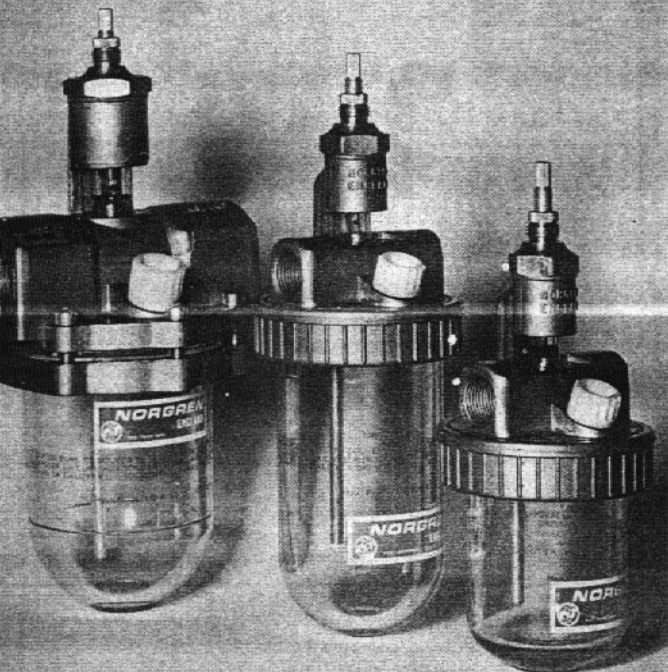

## WHERE TO USE

### Tests prove air tools operate over 20 times longer when lubricated properly

Designed to provide lubrication for air tools, air cylinders, and other air operated equipment. One lubricator should not normally serve more than two tools.

If the tool operates over a widely varying range of air flows, use a Constant Density Lubricator. Micro-Fog Lubricators are recommended where there are lengthy complex piping systems or multiple points of lubrication.

## WHY LUBRICATE AIR TOOLS?

The proper lubrication of pneumatic tools and cylinders prevents friction damage and rust corrosion, thereby increasing their working life substantially. Lubrication reduces down-time, lowers maintenance and replacement costs.

Actual comparative tests using a control group of like air-powered tools with and without lubrication have shown that the tools with lubrication will last 20 times as long as the air tools without any lubrication.

For flexibility of installation, most 'E' Type Oil Fog Lubricators can be easily adjusted for either left-to-right or right-to-left air flow.

An oil feed adjustment conveniently located on top of the lubricator controls the rate of oil feed through the sight feed glass. You know the lubricator is functioning and how much oil is going into the air stream.

Adjustment can be made from one drop per minute to a full stream of oil.

Whether on intermittent or continuous operation, the lubricator will provide properly lubricated air whenever the air is flowing.

## TYPICAL PERFORMANCE CHARACTERISTICS

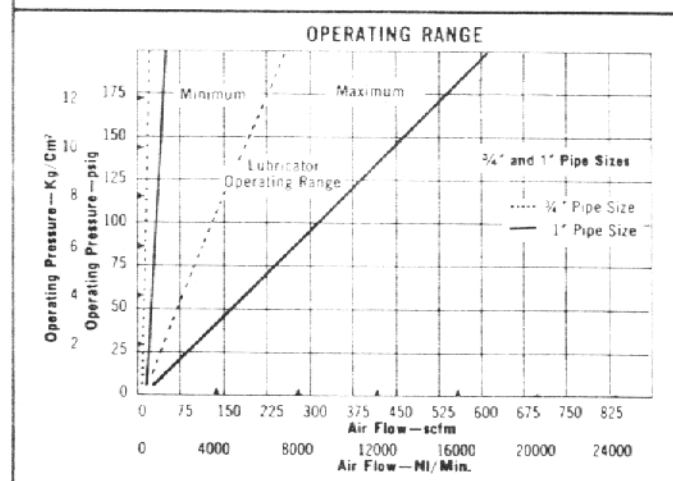
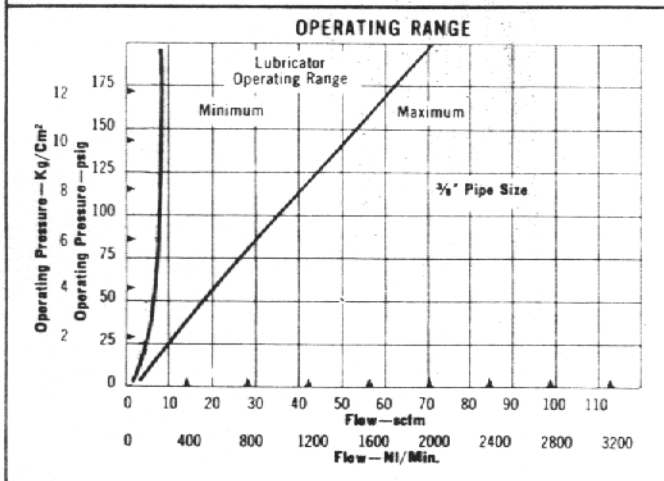
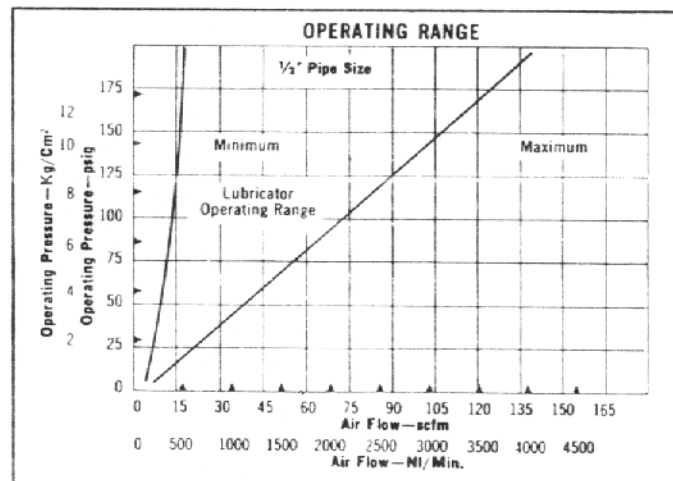
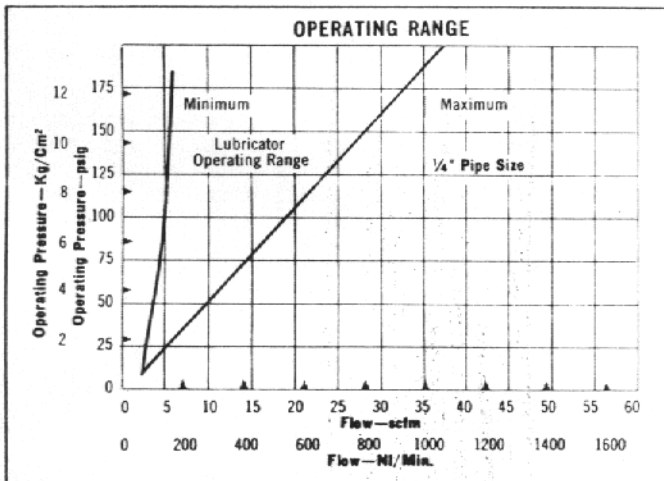

## OPERATION

To adjust, slacken knurled lock nut (A), close needle (B) fully, turn on air and open needle until required oil flow is seen through sight glass (approx: 1 drop of oil required per 10 c.f.m.). Tighten knurled lock nut after adjustment.

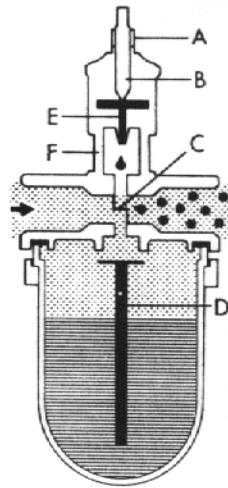

Air enters the lubricator as indicated. Air flowing through the lubricator causes a suction as it passes through the venturi section (C). Thus, oil is caused to flow up the syphon tube (D) to the chamber above the drip gland. Here the flow of oil is controlled by a needle valve and permitted to drip at the desired rate of feed from the drip gland (E), through the sight feed chamber (F) and into the air line. As oil enters the air stream, it is atomized into an air-borne oil fog which is carried to the pneumatic device.

*The check valve ball and spring permits the reservoir to be refilled without shutting off the air supply.*

## INTERNATIONAL PNEUMATIC SYMBOL



## DIMENSIONS

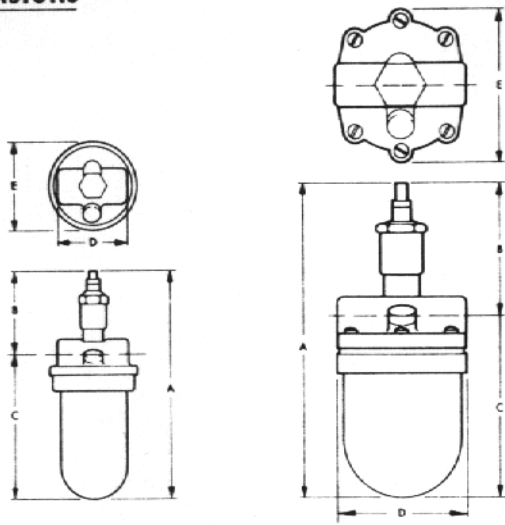

3 OZ. & 1/4 PT. SIZES

1/2 PT. SIZE

Nominal Oil Capacity	Pipe Size	DIMENSIONS — Inches and Millimetres				
		A*	B	C*	D	E
3 oz.	1/4", 3/8"	6 1/2	2 1/2	3 1/2	2 1/2	2 1/2
		161	71	90	59	73
1/4 pt.	1/4", 3/8"	7 1/2	2 1/2	4 1/2	2 1/2	2 1/2
		197	71	125	59	73
1/2 pt.	1/4", 3/8", 1/2"	8 1/2	3 1/2	4 1/2	3 1/2	3 1/2
		213	94	119	86	97
	3/4", 1"	8 1/2	3 1/2	4 1/2	4	3 1/2
		223	98	125	102	97

\* For Series S0-41E and S0-42E, add 1/4" (3 mm) to dimensions A and C.  
For Series S0-40E add 1/8" (5 mm) to dimensions A and C.

## MOUNTING DIMENSIONS

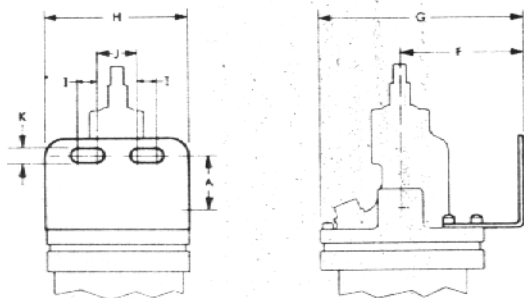









Nominal Oil Capacity	Pipe Size	DIMENSIONS — Inches and Millimetres						
		A	F	G	H	I	J	K
3 oz., 1/4 pt.	1/4", 3/8"	1 1/2	1 1/2	3 1/2	2 1/2	1 1/2	1 1/2	1 1/2
		16	46	84	63	13	22	7
1/2 pt.	1/4", 3/8", 1/2"	1 1/2	2 1/2	4 1/2	3 1/2	1 1/2	1 1/2	1 1/2
		37	57	106	83	16	32	7
	3/4", 1"	1 1/2	2 1/2	4 1/2	3 1/2	1 1/2	1 1/2	1 1/2
		30	57	106	83	16	32	7

## ORDER TABLE

Nominal Bowl Capacity	*Pipe Size B.S.P.T.	Standard Models	Optional Models
		Transparent Bowl	Metal Bowl
3 oz.	1/4"	0-39-2E	—
	3/8"	0-39-3E	—
1/4 pt.	1/4"	0-40-2E	S0-40-2E
	3/8"	0-40-3E	S0-40-3E
1/2 pt.	1/4"	0-41-2E	S0-41-2E
	3/8"	0-41-3E	S0-41-3E
	1/2"	0-41-4E	S0-41-4E
	3/4"	0-42-6E	S0-42-6E
	1"	0-42-8E	S0-42-8E

\* Alternative pipe threads B.S.P.P. and A.N.P.T. must be specified.

## ACCESSORIES

 <b>Mounting Brackets</b> For use on any vertical surface. Heavy gauge steel. Screws included	For Series 0-39E, 0-40E, S0-40E 1/4" size 3/8" size  For Series 0-41E, 0-42E, S0-41E, S0-42E All sizes	18-001-999 (W-62) 18-001-998 (W-63)  18-001-017 (W-2)
 <b>Syphon Tube Filter</b> 200 Mesh Monel screen ensures delivery of clean oil.	For all models	1788-01
 <b>Draincock</b> Models available with draincock fitted to bowl.	For all models	Specify
 <b>Tamper-proof Cap</b> Prevents unauthorised adjustment of lubricator setting. Hexagon cap screws down over Top Plug Assembly.	For all models	2131-99
 <b>Bowl Guard</b> (with modified clamp ring and special bowl). Expanded metal cage gives positive protection yet allows visibility of bowl contents.	For Series 0-40E  For Series 0-41E, 0-42E	18-012-993  18-012-997
 <b>Streamline Wyes</b> Improve efficiency of fog delivery.	Inlet 1/4" B.S.P., 2 outlets 1/4" B.S.P.  Inlet 1/4" A.N.P., 2 outlets 1/4" A.N.P.	18-006-987  18-006-016
 <b>Aerosol Distributor</b> Simplifies piping arrangement.	Inlet 1/4" B.S.P., 8 outlets, 1/4" B.S.P. Outlets not required are plugged—specify.	18-005-002 (A1-8)
 <b>Venturi Bushings</b> Reduce venturi section for low air flow applications.	For 1/4" Pipe Size. Minimum Flow at 80 p.s.i. (5.6 kg/cm <sup>2</sup> ) 2.2 cfm (62 litres/min)	3 oz., 1/4 pt. 1643-01  1/2 pt. 1506-01

## RAPID CYCLE MODELS

These models are designed to provide oil for rapid-cycle applications such as welding machines. Consult Factory for full details.

## NORGREN COMPATIBLE PRODUCTS

Norgren also offers similar lubricators with 1 qt., 1 1/2 gal., and 5 gal., nominal oil capacities as well as compatible filters and regulators.

## MAINTENANCE

To dismantle, shut off air, remove clamp ring (23, 24) and detach bowl (22); unscrew check valve seat (17) and syphon tube (19) to remove balls (15, 18) and spring (16). Unscrew top plug (2) and drip gland (7) and push venturi tube (11) and sight tube (9) out of top of body. TO CLEAN THE TRANSPARENT BOWL, WASH IN SOAPY WATER, DO NOT USE SOLVENTS AS THEY WILL DESTROY THE BOWL. Clean parts with paraffin and blow out with air. On re-assembly smear rubber parts with silicon grease.

Hold sight glass while firmly tightening drip gland. Male cone of pressure disc(5) must face downwards. Tighten clamp ring firmly. If venturi bushing is fitted, insert from inlet or outlet port and line up holes to receive stem of venturi tube.

(1) If oil fails to flow, ensure lubricator is correct size for task (see Performance characteristics). Check air flow direction corresponds with arrows on venturi tube. Thoroughly clean all oil passages with paraffin and compressed air. Examine check valve ball and seat for foreign matter. Check sight tube for hairline cracks. If oil still fails to flow, examine check valve seat to ensure seat still slightly spoilt.

(2) If oil or air leaks around sight glass tube, tighten drip gland. If this fails to stop leak inspect sight tube washers (8, 10).

## PARTS

### FOR 3 OZ. AND 1/2 PT. MODELS

GASKET KIT	040E-GK
Comprises:	
19a Gasket, Syphon Tube	1802-01
12a Gasket, Filler Plug	1955-01
3 Gasket, Top Plug	1188-01
6 Felt Disc	1006-01
10 Lower Sealing Washer	1189-01
8 Upper Sealing Washer	1190-01
20 'O' Ring (2 1/2" o.d.)	131-01
4a 'O' Ring (1 1/2" o.d.)	705-01
- Packing (Pre 1966)	1214-99

REPAIR KIT	040E-100
Comprises:	
Gasket Kit	040E-GK
16 Check Valve Spring	998-01
12 Filler Plug Assembly	1186-02
4 Needle Assembly (includes 'O' Ring)	1202-92
5 Pressure Disc	1005-01
15,18 Stainless Steel Ball (2 off)	1004-01
9 Sight Glass Tube	1179-01

FURTHER REPLACEMENT PARTS	
22 Bowl, Transparent (0-39)	0-73
22 Bowl, Transparent (0-40)	278-94
- Bowl, Transparent with draincock (0-39E) alternative	0-30
- Bowl, Transparent with draincock (0-40E) alternative	278-96
22 Bowl, Metal (50-40E)	588-99
- Bowl, Metal with draincock (50-40E) alternative	588-97
23 Clamp Ring	1994-02
17 Check Valve Seat	999-01
7 Drip Gland	1181-01
12 Filler Plug Assembly	1186-02
- Needle (early models)	1184-99
- Needle Assembly (includes 'O' Ring)	1202-92
1,2,4 Top Plug Assembly, complete	18-004-990
1 Knurled Locknut	619-96
11 Reversible Venturi Tube	1140-01
9 Sight Glass Tube (metal bowl units)	1179-01
9 Sight Plastic Tube (transparent bowl units)	1179-99
19 Syphon Tube Assembly (0-39E) inc. gasket	231-99
19 Syphon Tube Assembly (0-40E) inc. gasket	1819-01

### FOR 1/2 PT. MODELS

GASKET KIT	042E-GK
Comprises:	
19a Gasket, Syphon Tube	1802-01
3 Gasket, Top Plug	1280-01
13a Gasket, Filler Plug	1956-01
21 Gasket, Bowl	1029-01
10 Lower Sealing Washer	1210-01
8 Upper Sealing Washer	1212-01
- Packing (Pre 1966)	1214-99
6 Felt Disc	1006-01
4a 'O' Ring (1 1/2" o.d.)	705-01

REPAIR KIT	042E-100
Comprises:	
Gasket Kit	042E-GK
16 Check Valve Spring	998-01
13 Filler Plug Assembly	1206-02
4 Needle Assembly (includes 'O' Ring)	1202-92
5 Pressure Disc	1005-01
15,18 Stainless Steel Balls (2 off)	1004-01
14 Screws (set of six)	1031-91
9 Sight Glass Tube	1196-01

FURTHER REPLACEMENT PARTS	
17 Check Valve Seat	999-01
7 Drip Gland	1197-01
13 Filler Plug Assembly	1206-02
11 Reversible Venturi Tube (1/2", 3/4", 1")	1433-01
11 Reversible Venturi Tube (1/2", 1")	1434-01
9 Sight Glass Tube (metal bowl units)	1196-01
9 Sight Plastic Tube (transparent bowl units)	1196-99
- Needle (early models)	1202-99
4 Needle Assembly (includes 'O' Ring)	1202-92
1,2,4 Top Plug Assembly Complete	18-004-991
1 Knurled Locknut	619-96
22 Bowl, Transparent	216-77
- Bowl, Transparent with Draincock (alternative)	216-16
22 Bowl, Metal	2101-98
- Bowl, Metal with Draincock (alternative)	2101-91
24 Clamp Ring	1018-02
19 Syphon Tube Assembly, inc. Gasket	1819-01

WHEN ORDERING SPARES, QUOTE MODEL NUMBER AND KIT OR PART DESCRIPTION

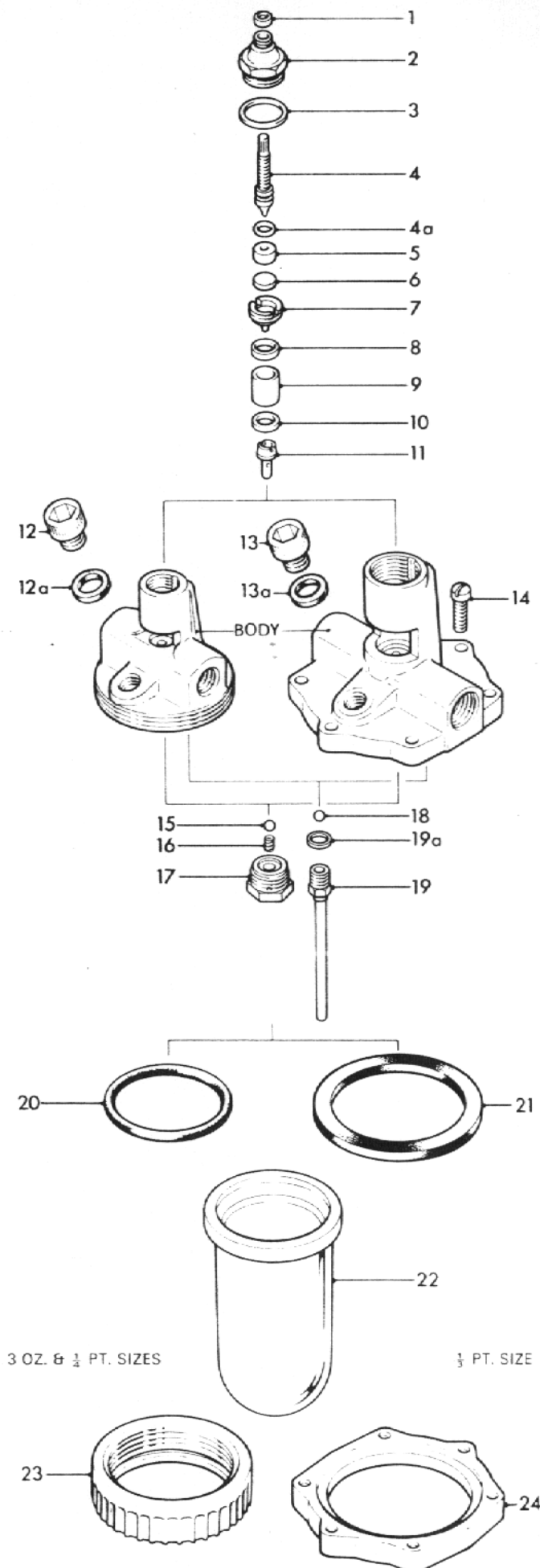

3 OZ. & 1/2 PT. SIZES

1/2 PT. SIZE

**C.A. NORGREN LTD**

SHIPSTON-ON-STOUR, WARWICKSHIRE, ENGLAND

EINC-301a 2/69