

WINGET

OPERATION, MAINTENANCE & SPARE PARTS MANUAL

7/200 THH MIXER

EXPORT SPECIFICATION

**PUBLICATION No S98
PRINTED MARCH 1981
REPRINTED JUNE 2003**

**WINGET LIMITED
PO BOX 41
EDGEFOLD INDUSTRIAL ESTATE
PLODDER LANE
BOLTON
LANCS
BL4 OLS**

**TEL: ++ 44 (0) 1204 854650
FAX: ++ 44 (0) 1204 854663
service@winget.co.uk
parts@winget.co.uk
www.winget.co.uk**

WINGET

TILTING DRUM MIXER

7/200 THH

EXPORT SPECIFICATION

This manual is a reprint of the Winget publication No S98 last printed during March 1981 and is a direct copy of one of the remaining original manuals.

Winget Limited have always operated a policy of continuous product development. Therefore, some illustrations or text within this publication may differ from your machine. The contents of this manual although correct at the time of publication during March 1981, may have been subject to alteration by the manufacturers in the intervening years without notice and Winget Limited can accept no responsibility for any errors or omissions contained within the following pages. Nor can we accept any liability whatsoever arising from the use of this manual howsoever caused.

Winget

INTRODUCTION

The operating instructions and maintenance recommendations contained in this book will enable you to become familiar with your mixer to obtain the best results in the shortest possible time.

The life and trouble free running of your machine will depend largely on the care it receives. It is your responsibility to ensure that the maintenance instructions outlined in this book are carried out.

When replacements are required, it is essential that only genuine parts are used and that any repair or servicing work is carried out by competent mechanics.

WINGET LTD.

GUARANTEE

As every reasonable care is taken that goods of this Company's manufacture shall be free from defect in material and workmanship, the Company will supply free to any destination in the British Isles named in the tender or F.C.S. British Ports in the case of goods situated abroad, any part or parts which, under normal service, appears to the Company's satisfaction to have been at the time of delivery defect in such parts, provided it is notified thereof within 12 months or 2,000 working hours from the date of delivery (whichever shall be the earlier) or, where the Company is responsible for erection, within twelve months from the date on which the customer is notified that any plant or machinery is ready for starting up provided that:-

- a) Written notice is given to the Company within seven days of the discovery of the defect.
- b) Unless otherwise agreed, the alleged defective part or parts are returned to the Company's Works, carriage-paid and its inspection establishes the claim. Replaced parts shall become the property of the Company.
- c) No part which is not of the Company's manufacture has been fitted, otherwise than by it or on its behalf, or with its written approval.
- d) No unauthorised alteration or modification has been made to the machine or component the subject of the claim.

In no cases shall the Company be responsible for the cost of fitting replacement parts.

Machines parts or components sold by the Company but not of its manufacture are subject only to such warranty (whether expressed or implied by law) as is given by the makers thereof and are not covered by this Guarantee. The Company will as far as is practicable make available to the purchaser the benefit of any warranty given to the Company by the makers of such machines or components.

This Guarantee and/or warranty is personal to the Company's customer and may not be assigned.

Any other warranty or condition expressed or implied by law and whether statutory or otherwise is hereby excluded as is also any claim based on any verbal or other representation or conditions made in relation to any goods the subject of any offer or tender submitted by the Company unless confirmed in writing by a Divisional Director or the Secretary of the Company.

Save as aforesaid the Company shall not be responsible for any loss or injury or damage however caused or arising.

This guarantee is extracted from the Company's standard conditions of sale.

LIST OF CONTENTS

<u>PAGE</u>	<u>DESCRIPTION</u>
1	Installing your Mixer on Site
1	Transporting the Mixer
1	Removing the Hopper
1	Lifting the Mixer
1	Drum Controls
1 & 2	Tilting Wheel Lock
2	Hopper Operation
2	Control
2	To Raise Hopper
2	To Lower Hopper
2	Water Tank
2	Filling the Tank
3	Discharging the Tank
3	Draining the Tank
3	Batch Weigher
3	Normal Operation
3	To Zero the Weighing Gauge
4	Hoist Winch
4	Controls
4	Controls Settings
4	Before Starting up
4	To Mix Concrete
4	When Working is finished
5	Lubrication
5	General
5	Transmission
5	Chain Tensioning
5 & 6	Water Tank Setting
6	Hydraulic System
6	Header Tank
6	Recommended Oils
6	Filter Removal
7	Dismantling the System
7	Batch Weigher
7	Tyre Pressures
7	General Maintenance
8	Servicing Schedule
24	How to find a Spare Part
24	How to order Spares
25	Spares Group
 <u>ILLUSTRATIONS</u>	
9 (Fig. 1)	General Arrangement
10 (Fig. 2)	Water Tank (with or without Sight Glass)
11 (Fig. 3)	Lubrication

Description & Operation

INSTALLING YOUR MIXER ON THE SITE (Fig. 1)

Ensure that the mixer is sited on firm ground and standing level in both directions. If the ground is loose or made up, it is recommended that the mixer be stood on stout timbers.

If pneumatic roadwheels are fitted, place a stout timber under each pair of stabilizing jacks, attached to the front and rear axles, lower the stabilizing jacks until they come firmly into contact with the timber, lock in position. Screw the two stabilizer bolts down on to the front axle and chock the wheels firmly in position. Extend the outrigger arm, if fitted, and secure in position. Remove and stow the towing bar, replacing the drop end pin in the steering bracket. Release the hopper safety prop. This is done by turning the engine by hand with the hopper control lever held in the 'raise' position until the weight of the hopper is taken off the prop. Turn retaining latch upwards and swing the prop downwards into its lowest position. Hold the hopper control in the 'lower' position and allow the hopper to come down under its own weight. If a batch weigher is fitted, ensure at least 2" (50 mm) clearance between the base of the hopper and the ground to ensure accurate readings to be obtained.

TRANSPORTING THE MIXER

To reduce the overall height of the mixer, it is possible to remove the loading hopper from its cradle.

REMOVING THE HOPPER

Under certain circumstances it may be desirable to remove the hopper. This is readily affected by removing the eight bolts attaching the hopper to the cradle. Alternatively, it might be desired that the hopper be removed with the cradle still attached. In this case the hopper pivot shaft and the two upper ram yoke pins should be removed allowing the hopper and cradle to be detached. It is advisable to replace the hopper pivot shaft in the cradle and the ram yoke pins in the yoke to avoid loss in transit.

LIFTING THE MIXER

Lifting eyes are provided for using crane hooks when loading for transporting. They are located, one on the left-hand side of the hopper cradle, when looking at the machine from the hopper side, the second one at the top of the trunnion pedestal next to the engine housing. Lifting the mixer should be carried out with the hopper up, or if the hopper has been removed for transporting, with the cradle in the UP position.

DRUM CONTROLS

Any of three pre-set positions CHARGE - MIX - DISCHARGE can be obtained. It is possible to alter the MIX position for a wet or dry mix, by removing the two set bolts holding the adjustable locking flange (Fig. 1) and moving it through half a turn, then replacing the set bolts.

TILTING WHEEL LOCK

A push-pull type locking mechanism located in the hub of the tilting handwheel gives positive locking in any of the three pre-set positions. To release the handwheel, simply pull the locking plunger outwards. To lock the handwheel, move the drum into the position you require, line up the pointer at the edge of the tilting wheel with the fixed pointer bolted to the tilting wheel guard, and

2 Winget

push the locking plunger in.

WARNING: Do not hold the locking plunger in and turn the handwheel to engage the lock, this will cause damage to the locking mechanism.

HOPPER OPERATION

CONTROL

The hydraulic control valve for operating the hopper is mounted on the trunnion pedestal near to the tilting handwheel.

TO RAISE HOPPER

Lift the control lever and hold it until the hopper is fully up. Do not hold the control in the RAISE position with the hopper up for more than a few moments or overheating and loss of efficiency will result.

TO LOWER HOPPER

Push the control lever downwards; releasing the lever will check the descent of the hopper as necessary.

WATER TANK (Fig. 2)

Amounts of water, from 1.1/2 to 8 gallons (7 to 36 litres) can be automatically measured. The amount of water to be discharged is selected by setting the pointer on a graduated scale mounted on the side of the tank. Remember to release and re-tighten the clamp nut holding the pointer each time the pointer is moved. Filling and discharging of the tank is automatic. When the drum is moved into the CHARGE position, it opens through a spring tensioned linkage the discharge valve in the tank, which allows the water to flow into the drum. Then, when the drum is moved into the MIX position the tank refills automatically.

FILLING THE TANK

With the drum in the MIX or DISCHARGE position the sequence of filling the tank is as follows:-

The float arm 'A' rests on the bottom of the float chamber and holds the trip lever 'B' against the pilot valve 'P' to hold it open against the action of the spring 'S'. Water enters the tank at 'C' and lifts the diaphragm 'D' off its seat allowing water to flow into the tank. It also passes through a supply bleed hole and past the pilot valve to enter the tank.

Incoming water passes down the transfer pipes 'E' and fills the airtight chamber 'F' until the water covers the end of the air pipe 'G' when this happens no further water is admitted to the air tight chamber, instead the transfer pipes and float chamber flood until the float rises and allows the trip lever 'B' to disengage from the float cam 'R' allowing the pilot valve 'P' to close, assisted by the action of the spring 'S'. Pressure increases on the upper side of diaphragm 'D' causing it to reseat, shutting off the incoming water supply.

DISCHARGING TANK

When the mixing drum is moved into the CHARGE position the rod 'H' is pulled downwards, this, through the linkage, causes the discharge valve 'J' to lift off its seat discharging the contents of the tank.

The float cam 'R' is also moved by the linkage away from the trip lever 'B' allowing the float to drop into the bottom of the chamber when the water is discharged. When the drum is moved into the MIX position, the rod 'H' is lifted by the return spring 'K'. The discharge valve 'J' is closed, the float cam 'R' moves into contact with the trip lever 'B' which opens the pilot valve 'P' to start filling tank again.

DRAINING THE TANK

During periods of frosty weather, to avoid damage, it is advisable to drain the tank at the end of each day's working. To do this set the drum in the CHARGE position and drain the water into the drum, then disconnect the water supply to the mixer. Finally empty the water from the drum.

BATCH WEIGHER (if fitted)

The weigher gauge mounted in a box on the tilt end pedestal is connected by hydraulic piping to the loadcell mounted near the hopper lower pivot arm. The hydraulic circuit is primed and sealed on leaving the works and on no account should it be tampered with.

The gauge calibrated from 0-1,100 lb. (500 Kgs.) gives accurate indication of batch weights. The adjustable coloured pointers mounted on the rim of the gauge can be set by the operator to the aggregate proportions required. A protective lid is provided for the gauge box to prevent damage when not in use.

It is important that the mixer is standing firm and level and that there is at least 2" (50 mm) clearance between the ground and the base of the hopper at all times. If aggregate is allowed to build up inaccurate gauge readings will be obtained.

NORMAL OPERATION

Set the pointers on the gauge to the aggregate proportions you require. With the engine running lower the hopper slowly on to the loadcell. Hold the hopper control lever fully down for a few seconds until the gauge needle begins to move up to zero then release. The hopper is then ready to load. If you cannot get a zero reading adjust the gauge as described in the following paragraph:-

TO ZERO THE WEIGHING GAUGE

With the mixer engine running carry out the following:-

- (a) Lower the hopper on to the loadcell as described.
- (b) Check that the hopper is clear of the ground.
- (c) Taking care not to stand on any part of the hopper, adjust the knurled knob on the side of the gauge to set the point to zero.
- (d) Repeat, lowering the hopper three to four times to check that you obtain a consistent zero reading.

4 Winget

HOIST WINCH (if fitted)

The hoist winch is situated at the engine end of the machine and is designed to hoist loads of 10 cwt. (500 Kilos) this is sufficient to raise one complete mix of 7 cu. ft. (0.2m³) of concrete.

CONTROLS

To hoist, the outboard hand lever (that nearest the road wheel) is pulled upwards, this releases the brake and engages the clutch.

To lower, the inboard hand lever is eased upwards to release the brake.

The load can be arrested in any position during the raising and lowering operations simply by releasing the appropriate hand lever.

CONTROLS SETTING

To ensure complete safety the brake and clutch settings should be checked at regular intervals and adjusted when necessary.

REFER TO SECTION K1

First check that with the brake applied, the height of the spring stack, Ref. 35, is 2.1/8" (55 mm). If necessary adjust by means of nut and locknut on Ref. 36.

Now, if necessary, adjust the clutch for wear. This is carried out by removing the fixing screw and releasing the locknut for Ref. 43 at the hand lever end. Screw Ref 43 into Ref. 46 so that the brake band is just eased off when the clutch is fully engaged.

When the brake and clutch are correctly adjusted a raised load should not fall during movement of clutch lever.

BEFORE STARTING UP

Read carefully the Engine Manufacturer's Handbook supplied with this mixer. Check the amount of fuel in tank and the level of lubricating oil in engine sump.

With the hopper down check the level of oil in header tank. A combined filler cap and dipstick is provided.

Set the pointer on the water tank to the amount required for the first mix. With the drum in the MIX or DISCHARGE position, connect the mains supply to the tank, and it will automatically fill.

TO MIX CONCRETE

Set the coloured points on the weigher gauge (if fitted) to the aggregate proportions you require and load hopper.

Move the drum into the CHARGE position. The water will automatically start discharging at the same time, raise the hopper to tip the aggregate into the drum. When all the materials are in the drum, lower the hopper and load for next batch, and set drum in the MIX position.

After allowing a short interval for mixing, the concrete in the drum should discharge.

WHEN WORKING IS FINISHED

- (a) Thoroughly clean out the drum with water and gravel.
- (b) Clean out the hopper and wash down the outside of the mixer.
- (c) Drain water tank if frost is likely.
- (d) Raise hopper, place safety prop in position and lock.
- (e) Stop engine.
- (f) Grease up machine for next day's working.
- (g) Replace cover on weigher gauge box.
- (h) Lock engine housing to prevent tampering and loss of tools.

LUBRICATION

GENERAL

All shafts and bearings needing daily attention are lubricated through drilled shafts and special greaseways by fitting grease nipples. The lubrication diagram (Fig. 3) will give the location of these grease nipples, which should be greased daily, using a grease gun charged with a good quality medium grease (Shell Alvania RA).

It is essential that Operator's do not allow grease or oil used for servicing to become contaminated with sand or cement dust. Apply a little engine oil from time to time on pin joints on water tank controls, track rods on steering assembly and hinges on housings etc. Bearings must not be allowed to run dry; when greasing it is better to give a little often rather than a lot at long intervals.

TRANSMISSION

Lubricate the main bevel pinion drive chain and the pump drive chain once a week with a little engine oil. Check chain tension and adjust if necessary as described below.

CHAIN TENSIONING

On no account must chains be over-tightened, undue tightness puts excessive strains on pump and engine bearings causing vibration and considerable wear. A very rough guide to chain tension is to allow the equivalent amount of one chain pitch free movement on the slack side of the chain, i.e. 3/4" (19 mm) chain pitch - 3/4" (19 mm) slack etc.

WATER TANK SETTING

- 1) Lower edge of outer end of operating lever to be 1" (25 mm) above top edge of tank body when locknut 'L' on operating link 'M' seats on underside of angle bracket.
- 2) With outlet valve 'J' on seat, stiffnut on valve rod to be 1/8" (3.2 mm) clear of operating pin as shown.

6 Winget

- 3) With pilot valve on seat and trip lever in contact with it, clearance between trip lever and stop pin to be 1/32" (0.79 mm).

HYDRAULIC SYSTEM

HEADER TANK

This is mounted inside the drive end trunnion pedestal, easily accessible through the door in the pedestal.

The oil in the system is continually passed through a filter mounted in the tank, it also serves as a filling filter. It should be removed for cleaning and inspection every three months (600 hours running), this can be carried out without draining the tank and is described fully on this page.

Check the level of the oil weekly (50 hours running) with the hopper down and engine stopped. A combined filler cap and dipstick is provided for this purpose, but remember to clean the area around the cap before removing it, to prevent dirt falling into the tank.

RECOMMENDED OILS

Top up the system as necessary using an oil of the correct grade, do not mix different brands of oil. The approximate capacity of the system is three gallons and it is filled with Shell Rotells 10 at the works, the particular grade of oil being shown on a label attached to the top of the tank. Generally, if a diesel engine is fitted, any lubricating oil suitable for this, is suitable for the hydraulic system, in case of doubt use:-

SAE 10 oil for temperatures up to 60°F (16°C)

SAE 20 oil for temperatures between 60°F and 90°F. (16°C, 33°C).

SAE 30 oil for temperatures above 90°F. (33°C)

FILTER REMOVAL (See Spares Group E2)

This is done with the hopper down and the engine stopped as follows:-

- (a) Thoroughly clean the top of the tank and remove the combined filler cap and dipstick and bonded seal.
- (b) Unscrew the three set bolts securing the filter carrier cap taking care not to lose the sealing washers.
- (c) Remove the cap and gasket and lift out the compression spring and finally the filter. Cover the opening with a clean rag while the filter is out.
- (d) Thoroughly clean the filter in petrol only, and air dry thoroughly before re-assembly.
- (e) Replace filter, spring, gasket and cap in that order. Tighten cap fixing bolts, not forgetting to replace the sealing washers.
- (f) Top tank up with oil if necessary and replace dipstick and bonded seal.

DISMANTLING THE SYSTEM

Do not remove or expose any part of the internal hydraulic gear in the event of breakdown, unless so instructed, as this may lead to further complications when correcting the fault. Remember you have a WINGET SERVICE DEPOT near you which is always ready to assist.

BATCH WEIGHER (if fitted)

Include the four grease nipples on the upper hopper pivot links in your daily servicing.

To allow accurate functioning, keep the mechanism as clean as possible, special attention being paid to the lower link pivot. Clean the ground under the hopper frequently to avoid any build up of aggregate.

NOTE: On no account must the loadcell be disconnected from the weighing dial. No responsibility will be accepted by us, if the lead seals attached to the pipe unions are broken.

TYRE PRESSURES (if pneumatics fitted)

These should be checked at regular intervals and before transportation from site to site. Recommend tyre pressures 45 p.s.i. all round.

GENERAL MAINTENANCE

Check for tightness from time to time, all bolts, nuts, keys, etc. especially during the first few weeks of operation. Pay particular attention to engine fixing bolts. Clean top of header tank before removing filler cap. Add oil of recommended grade. Drain water tank during frosty weather.

When not in use, keep weigher gauge box lid on, and engine housing locked to prevent tampering and loss of tools.

8 Winget

SERVICING SCHEDULE

DAILY	
Mixer	Lubricate daily through grease nipples using a good quality medium grease. Shell Alvania RA is used at Works. (See lubrication diagram). Thoroughly clean out drum, when mixing is finished, with water and gravel. Wash out hopper, and hose down mixer. Keep access doors and panels closed. If frost is likely, drain water tank.
Hoist Winch	Check brake and clutch for adjustment
Engine Sump Lubrication Fuel Tank	See Engine Handbook
WEEKLY	
All Drive Chains	Lubricate chains with engine oil. Check tension and adjust if required
Hydraulic Header Tank	Clean top of tank. Check level and top up as necessary. Do not mix different brands of oil. Check with hopper down and engine stopped
General	Apply a little engine oil to all joints on water tank controls, track rods and hinges on housings etc.
THREE MONTHLY	
Hydraulic Header Tank Fitter	Remove, clean and inspect

NOTE: CHECK ENGINE MANUFACTURER'S HANDBOOK FOR ROUTINE MAINTENANCE INFORMATION

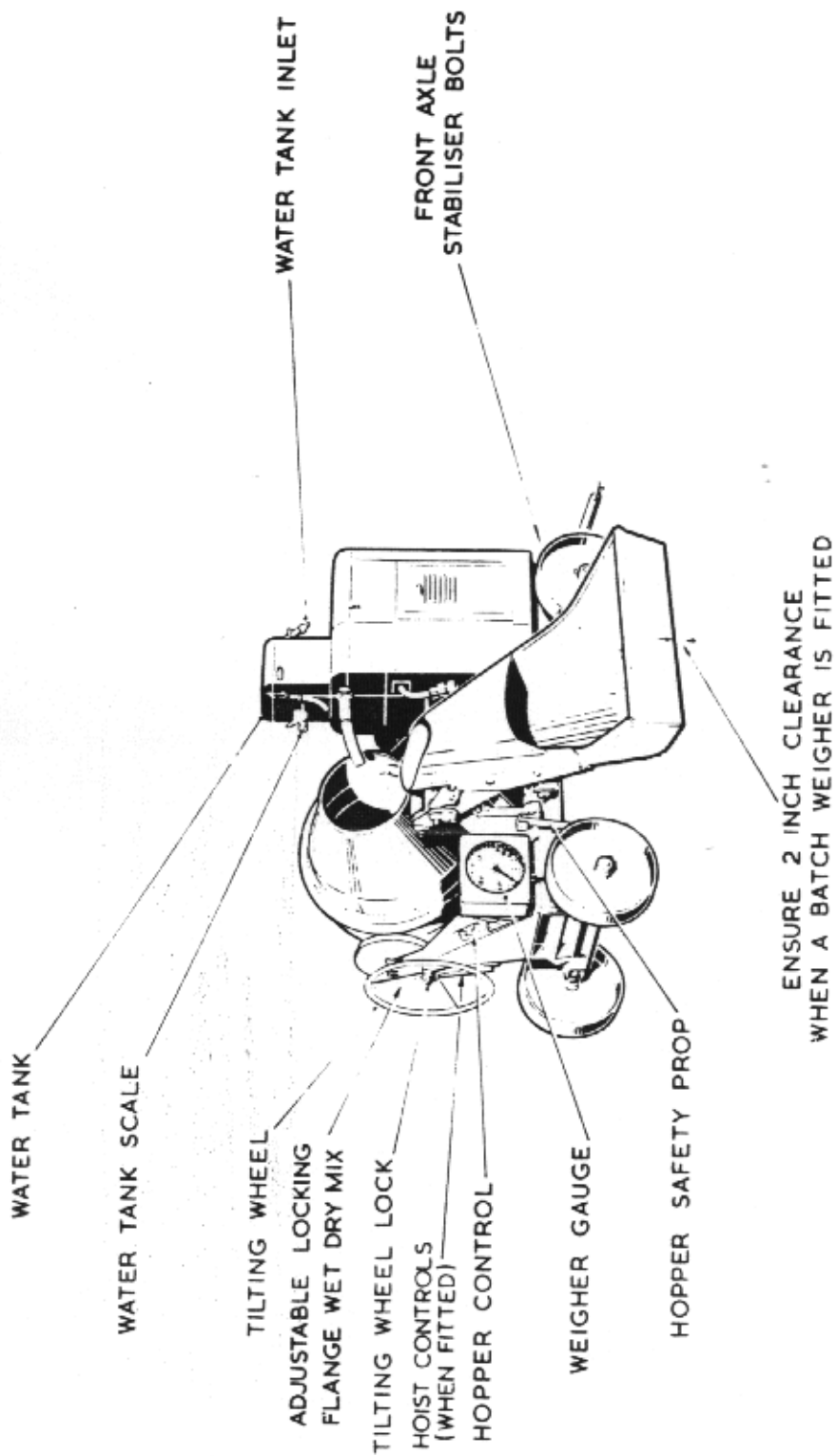

General Arrangement (Fig. 1)

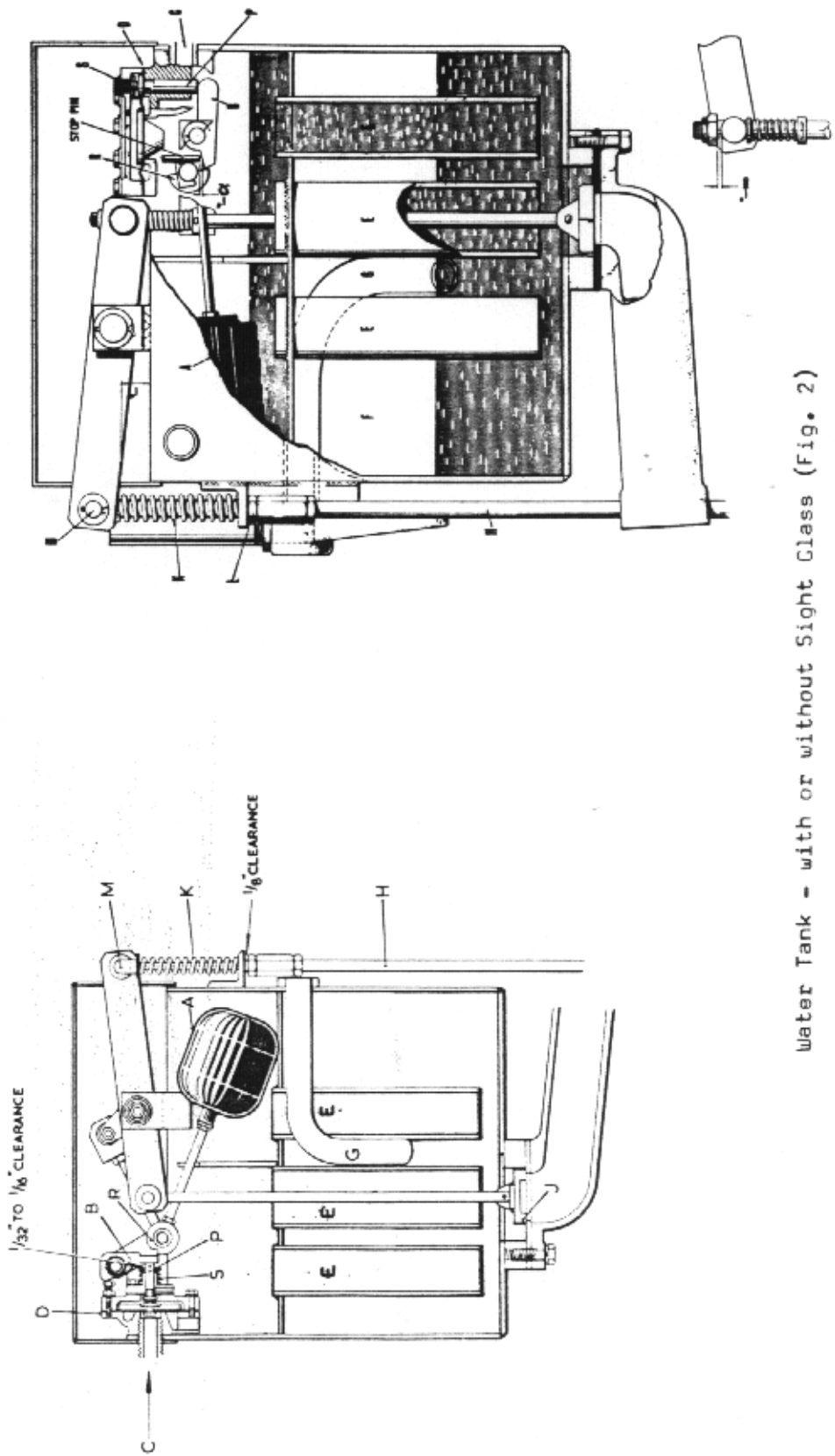

Water Tank - with or without Sight Glass (Fig. 2)

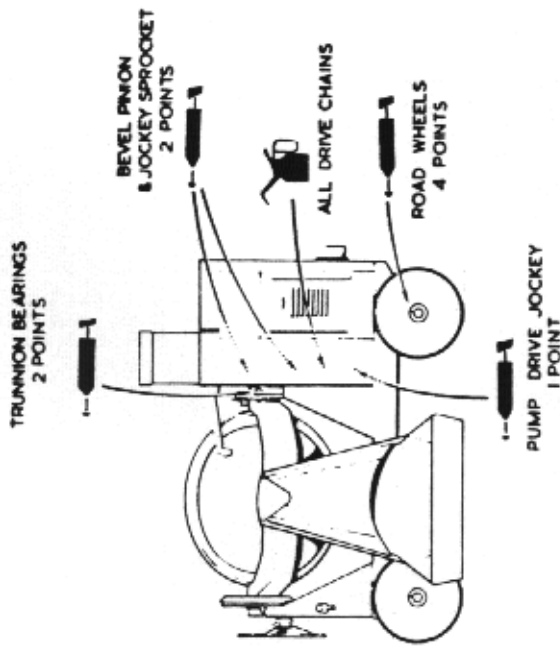

GIVE STAUFFERS ONE TURN DAILY & REFILL WHEN NECESSARY.

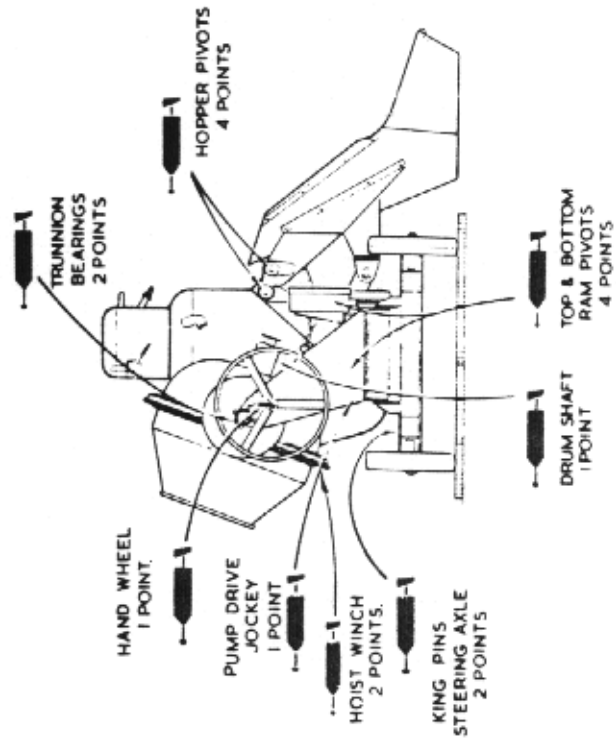

Lubrication Diagram (Fig. 3)

Spares

Please note that a number of components are described as being c/w screws, nuts and washers, this is no longer the case and all fixings should be ordered separately if required. Imperial fixings may no longer be available and the nearest metric equivalent will be supplied.

24 Winget

TO FIND A SPARE PART

The assemblies have been divided into groups and given identification letters A, B, C, etc. To identify a component, first find the relevant assembly in the list given on next page, this will give you a group letter to turn to. On turning to this group the illustrations will enable you to identify the part you require and give you a reference number. Against this number in the Parts List will be found the DESCRIPTION and PART NUMBER information which we require.

To avoid delays and errors, remember always to quote THE MACHINE NUMBER, which will be found stamped on a plate at the side of the machine.

Don't risk delays and errors remember
**ALWAYS QUOTE THE SERIAL NUMBER
OF THE MACHINE AND THE ENGINE
NUMBER**

SIZE OF MIXER	<input type="text"/>	YEAR MADE	<input type="text"/>
MIXING R P M	<input type="text"/>	WT. <input type="text"/>	CWTS. <input type="text"/>
RELEVANT B S S	<input type="text"/>	PATENT NO.	<input type="text"/>
WHEN ORDERING SPARES QUOTE MACHINE NO :-	<input type="text"/>		

SPARES GROUPS

- A.1. Mainframe Assembly
- B.1. Portability Assembly
- C.1. Drum and Trunnion Assembly
- D.1. Tilting Gear Assembly
- E.1. Pump Fixing and Jockey Assembly
- E.2. & E.6. Hydraulics Assembly
- E.3. Weston Ram Assembly
- E.4. & E.5. Ganus Ram Assembly
- F.1. Hopper and Cradle Assembly
- G.1. Weigher Assembly
- H.1. Water Tank Assembly (for tanks without sight glass)
- H.2. Water Tank Float Valve Details (for tanks without sight glass)
- H.3. Water Tank Controls Assembly (for tanks with or without sight glass)
- H.4. Water Tank Float Valve Details (for tanks with sight glass)
- H.5. Water Tank Assembly (for tanks with sight glass)
- J.1. Lister S.T.1. Drive Assembly
- J.2. Petter P.H.1. Drive Assembly
- J.3. Lister S.T.2. Drive Assembly
- K.1. Mechanical Hoist Assembly
- L.1. Guards Assembly Lister S.T.1.
- L.2. Guards Assembly Petter P.H.1.
- L.3. Guards Assembly Lister S.R.2. (for hoist machines only)
- Fastenings (Nuts, bolts, washers, etc.)
- L.4. Wiring Diagram

NOTE: Fastenings in List of Parts are given identification Nos. prefixed with letter 'Y'. To obtain Part Nos. for these fastenings, section 'Y' at the back of this manual should be referred to.

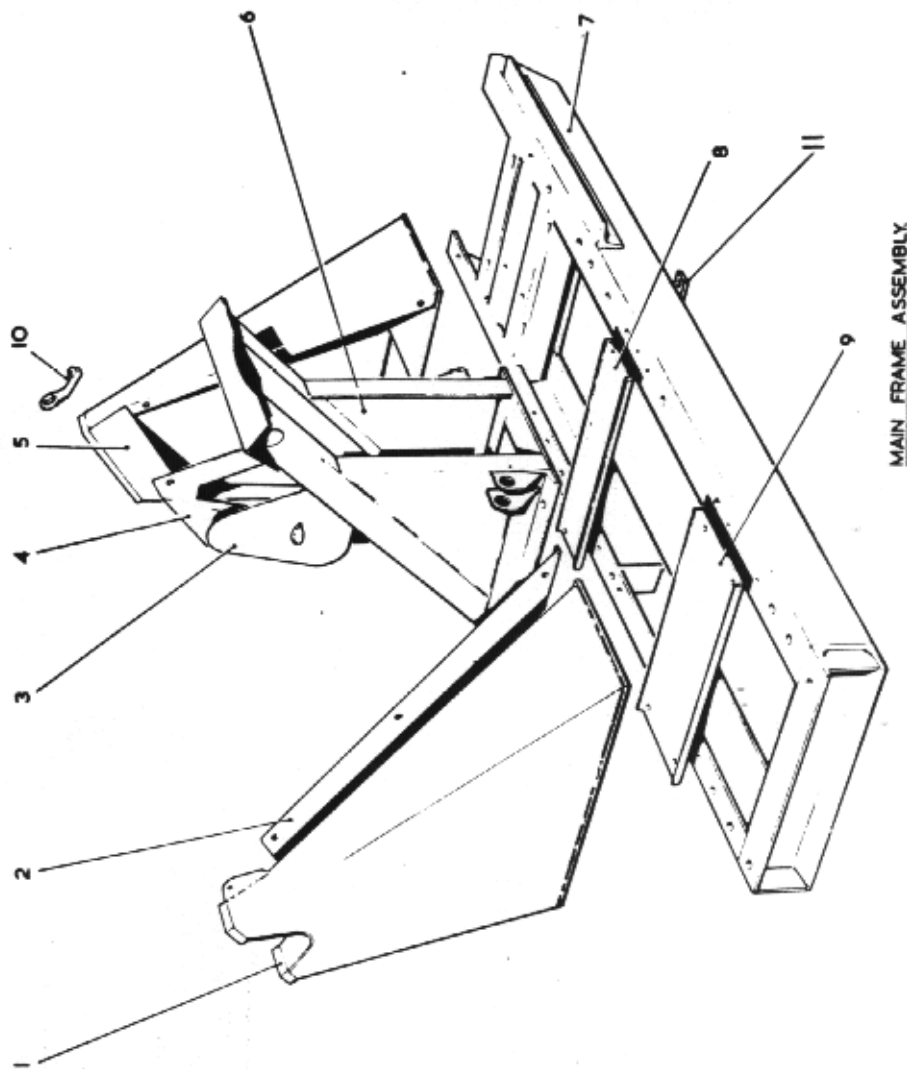

MAIN FRAME ASSEMBLY

Ref	Description	Part No	Qty
1	Trunnion Pedestal (Tilt End) Complete with Y26, Y114, Y227 & Y252	503 0532 00	1
2	Trunnion Pedestal Guard (Tilt End) Complete with Y79 & Y224	502 8673 00	6
3	Trunnion Pedestal Door (Drive End)	503 0546 00	1
4	Trunnion Pedestal Guard (Drive End) Complete with Y79 & Y224	503 0549 00	1
5	Trunnion Pedestal (Drive End) Complete with Y26, Y114, Y227 & Y252	503 0525 00	5
6	Hopper Pivot Frame Complete with Y26, Y114, Y227 & Y252	503 0526 00	1
7	Mainframe	513 2899 00	6
8	Trunnion Pedestal Lower Guard (Drive End) Complete with Y11, Y112, Y224 & Y250	502 8671 00	1
9	Trunnion Pedestal Lower Guard (Tilt End) Complete with Y11, Y112, Y224 & Y250	502 8672 00	4
10	Lifting Eye	502 8052 00	1
11	Load Cell Support Lug complete with Y22, Y113, Y226 & Y251	513 2900 00	1
			1

When Ordering :- Machine N°, Part N°, Description and Quantity
Always Quote

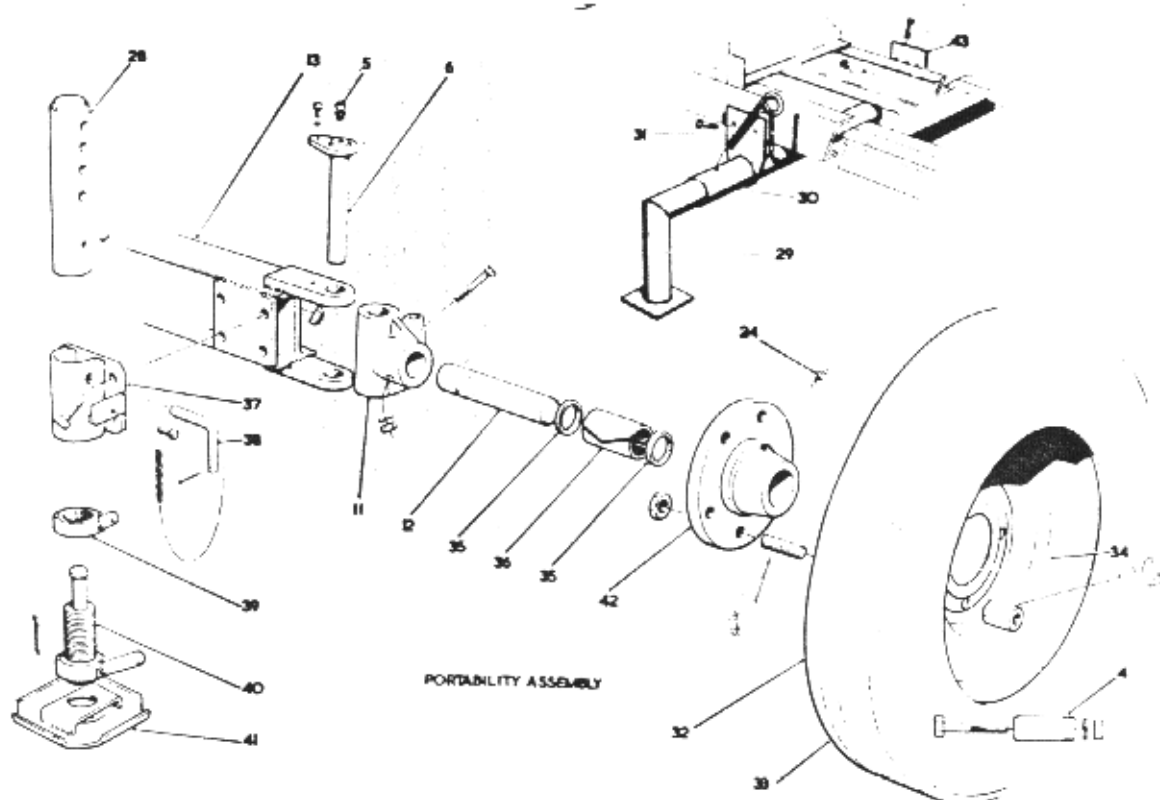
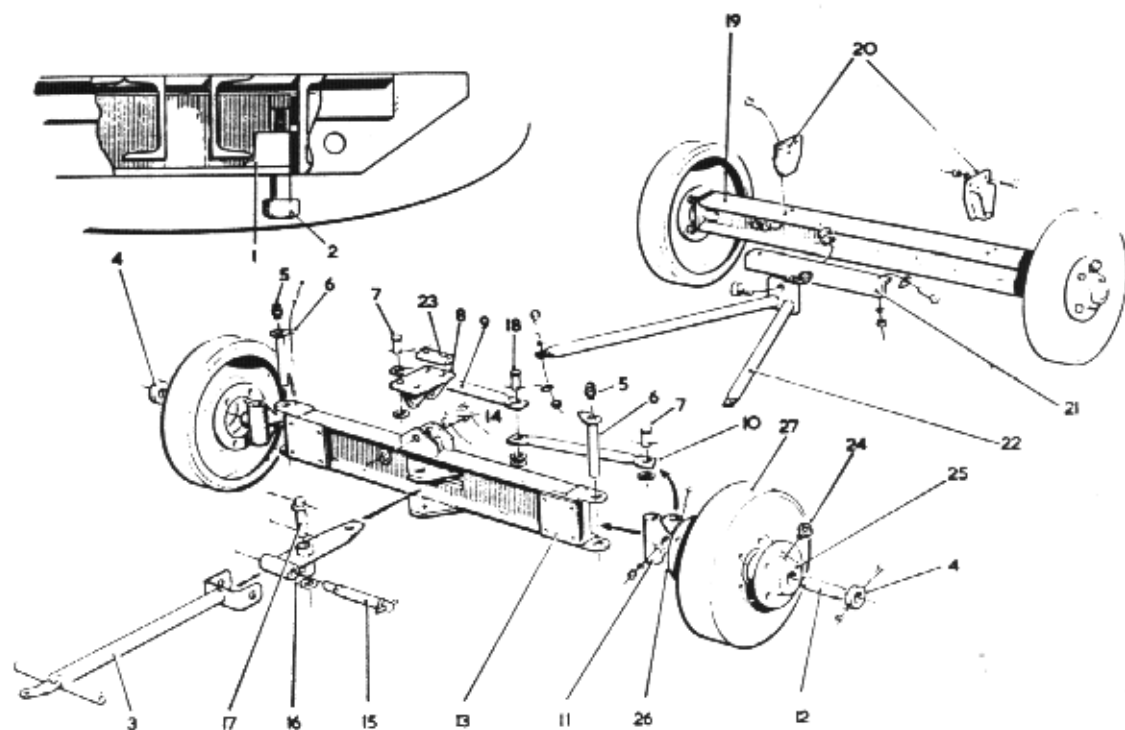

Ref	Description	Part N°	Qty
1	Stabilizer Nut	504 5501 00	2
2	Stabilizer Bolt	502 8181 00	2
3	Towbar	502 7755 00	1
4	Collar	145 5040 00	1
5	Complete with Y17, Y112 & Y224		4
6	Nipple	333 1022 00	2
7	King Pin	502 7761 00	2
8	Complete with Y9 & Y224		2
9	Pin for Trackrod	502 7816 00	2
10	Complete with Y258 & Y240		2
11	Front Axle Swivel Bracket	502 7801 00	1
12	Complete with Y21, Y113, Y226 & Y251		4
13	Offside Trackrod	502 7763 00	1
14	Nearside Trackrod	502 7762 00	1
15	Front Stub Axle	502 7756 00	2
16	Complete with Y115, Y112 & Y224		2
17	Stub Axle Pin	502 7757 00	2
18	Front Axle	502 7759 00	1
19	Swivel Bracket Pin	502 7813 00	1
20	Complete with Y242 & Y264		2
21	Towbar Pin	502 7818 00	1
22	Steering Bracket	502 7799 00	1
23	Steering Bracket Pin	502 7815 00	1
24	Complete with Y241 & Y260		2
25	Centre Track Pin	502 7817 00	1
26	Complete with Y240 & Y258		1
27	Rear Axle	502 7764 00	1
28	Complete with Y38, Y119, Y137 & Y251		4
29	Rear Axle Bracket	502 7821 00	2
30	Complete with Y21, Y113 & Y226		6
31	Tie Rod Cross Angle	502 7955 00	1
32	Complete with Y21, Y113, Y226 & Y251		2
33	Front Axle Tie Bar	504 5495 00	1
34	Complete with Y27, Y114 & Y133		1
35	Swivel Bracket Packing		2
36	Nipple	504 5505 00	1
37	Wheel Hub	333 7440 00	4
38	Backing Plate	513 1423 00	4
39		511 1654 00	4

Ref	Description	Part N°	Qty
27	Pressed Steel Roadwheel Complete with Y27, Y114 & Y227	511 1467 00	4
28	Tube for Stabilizer Complete with Y198	500 8696 00	16
29	Outrigger Leg	513 1282 00	4
30	Outrigger Support Tube Complete with Y23, Y113 & Y226	513 1283 00	8
31	Locking Pin with Dog Chain	513 1285 00	1
32	Tyre	475 3001 61	1
33	Tube	475 3001 62	4
34	Wheel with Nut and Locknut	475 3001 60	4
35	Distance Washer	501 8564 00	8
36	Bearing	113 1010 00	4
37	Stabilizer Bracket Complete with Y20, Y113 & Y132	502 8703 00	4
38	Locking Pin	501 1783 00	16
39	Locking Nut	508 6950 30	4
40	Lifting Screw Complete with Y243 & Y265	501 1505 00	4
41	Base for Stabilizer	508 6950 10	4
42	Roller Bearing Hub Adaptor	501 8219 00	4
43	Outrigger Bracket Complete with Y23, Y113 & Y226	513 1284 00	1
44	Wheel Stud	513 2515 00	3
45	WHEEL NUT	513 2556 00	16

NOTE: ITEMS 25, 26 and 27 USED WITH PRESSED STEEL ROAD WHEELS

ITEMS 28 to 44 INCLUSIVE USED WITH PNEUMATIC ROAD WHEELS

 When Ordering
 Always Quote

Machine N° , Part N°, Description and Quantity

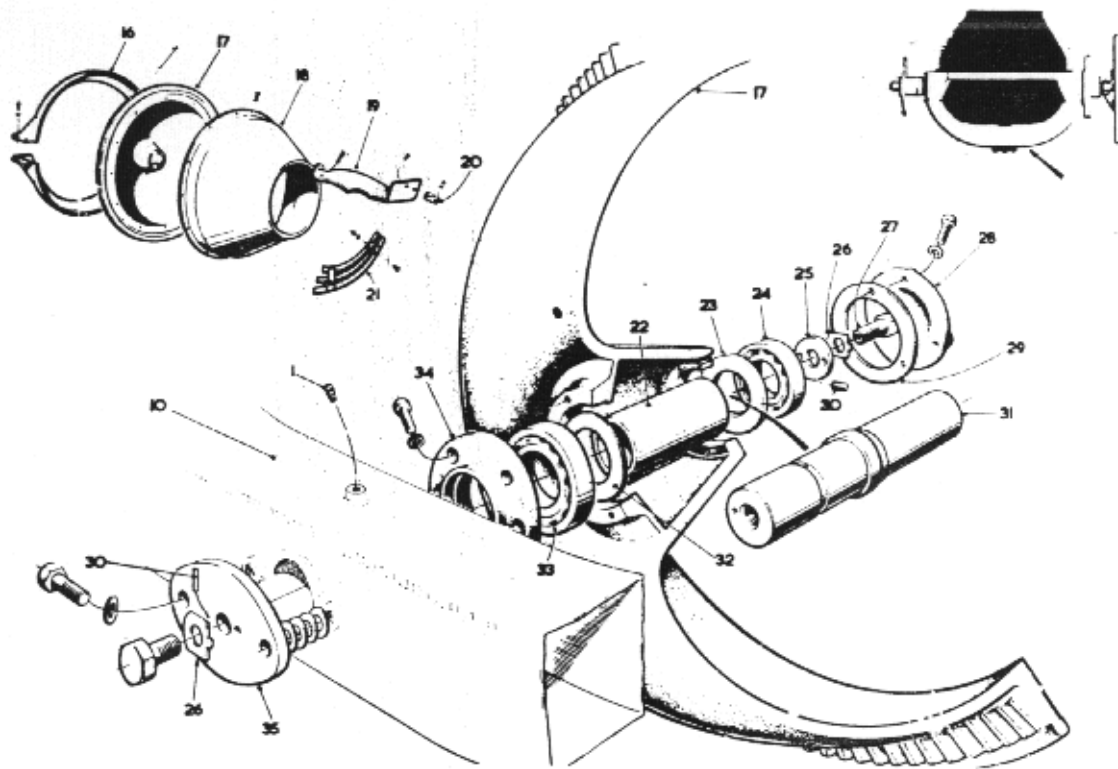
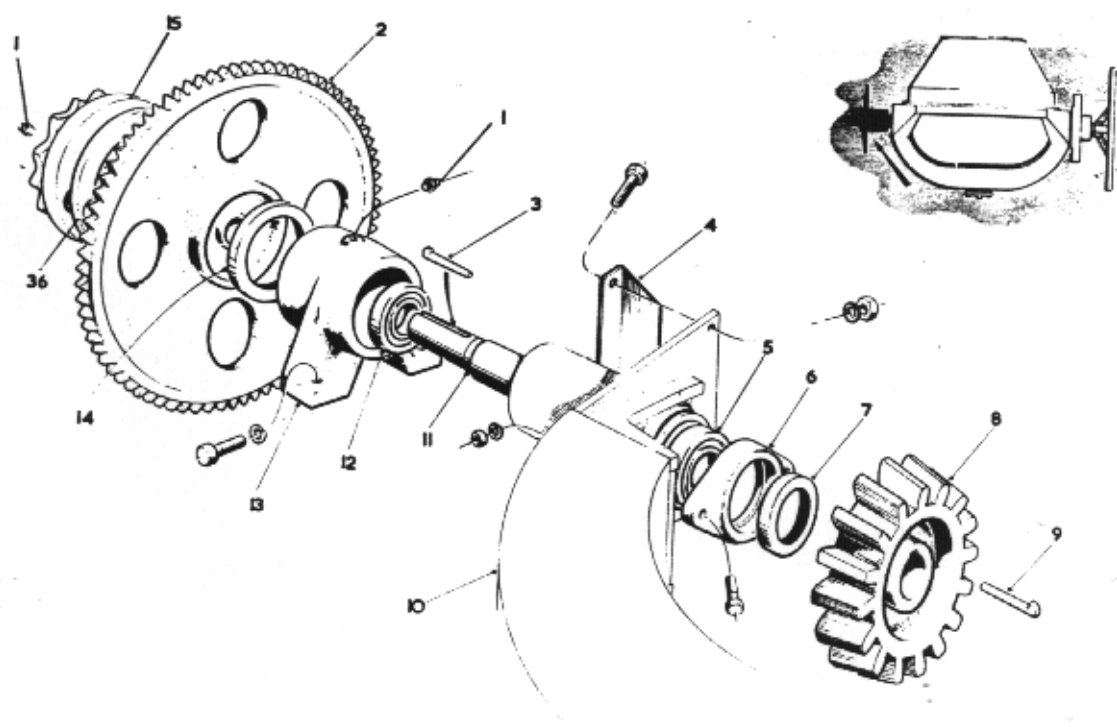

DRUM & TRUNNION ASSEMBLY

Ref	Description	Part N°	Qty
1	Nipple	333 1040 00	3
2	Chainwheel (Non-Hoist Machines)	503 0585 00	1
	Chainwheel (Hoist Machines only)	502 7848 00	1
3	Key (Non-Hoist Machines)	381 1062 90	1
	Key (Hoist Machines)	501 2503 00	1
4	Bevel Pinion Guard	102 2120 00	1
5	Bearing	501 1021 00	1
6	Locking Cap	417 1324 40	2
7	Complete with Y13, Y112 & Y224	501 1018 00	1
8	Oil Seal	381 1061 60	1
9	Bevel Pinion (18 TEETH)	501 1183 00	1
10	Key	501 1020 00	1
11	Trunnion	100 1120 00	1
12	Bevel Pinion Shaft	502 7899 00	1
13	Bearing	417 1608 00	2
14	Trunnion Bearing Bevel Pinion End	513 2397 00	1
15	Complete with Y95, Y114 & Y227	501 1718 00	4
16	Oil Seal	502 7568 00	2
	Hoist Drive Sprocket (Hoist Machines only)	502 7721 00	4
	Complete with Y33, Y118 & Y224	502 7728 00	2
	Drum Guard	502 7758 C0	2
	Complete with Y18, Y35, Y48 & Y83	502 4764 00	8
	Y112	502 7613 00	2
	Y224	502 7612 00	8
	Y118	102 2180 00	1
17	Drum Base	500 9280 00	1
18	Drum Top	504 5843 00	2
19	Complete with Y84, Y113 & Y226		
	Drum Blade Lower		
20	Complete with Y84, Y113 & Y226		
	Drum Blade Cleat		
21	Complete with Y190, Y113 & Y226		
	Skeleton Blade		
22	Complete with Y190, Y113 & Y226		
	Distance Tube		
23	Thrust Washer		
24	Bearing		
25	Retaining Washer		
26	Tag Washer		

When Ordering
Always Quote

Machine N°, Part N°, Description and Quantity

Ref	Description	Part N°	Qty
27	Special Bolt	502 7611 00	1
28	Drum Base Cap	502 7608 00	1
	Complete with Y23 & Y238	502 8287 00	3
29	Drum Base Cap Gasket	353 2058 00	1
30	Dowel	502 7607 00	2
31	Drum Shaft	502 7614 00	1
	Complete with Y30	102 2220 00	1
32	Crease Shield	502 7610 00	1
33	Bearing	502 7609 00	6
34	Bearing Cap		1
	Complete with Y156 & Y224		2
35	Flange for Drum Shaft		6
	Complete with Y28		1
	Y240		2
36	Spims for Hoist Sprocket (Hoist Machines only)	513 2513 00	1
	CHAIN 3/4" PITCH 80 TEETH	134106080	1
	FOR CHAINWHEELS		
	503058500		
	502784800		

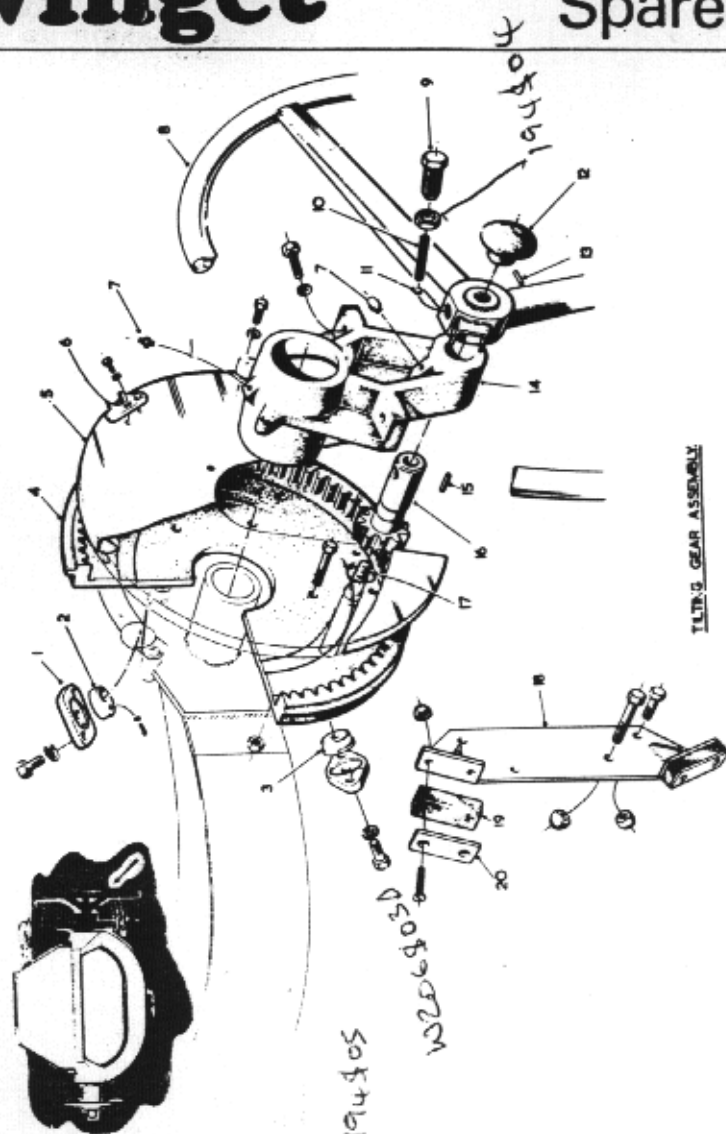

Ref	Description	Part No	Qty
1	Locking Flange Complet with Y86 & Y226	513 1226 00	3
2	Adjustable Locking Flange Boss	513 1228 00	6
3	Complete with Y157 & Y222	513 1227 00	1
4	Locking Flange Boss Tilting Wheel Complete with Y42 & Y44 Y147	502 7896 00	2
5	Tilt Wheel Guard Complete with Y72 & Y222 Y82 & Y224	513 1049 00	1
6	Pointer	513 1042 00	4
7	Nipple	333 1022 00	1
8	Hand Wheel	513 1048 00	2
9	Special Screw Complete with Backnut	513 1040 00	1
10	Compression	240 1040 00	1
11	Steel Ball	513 1039 00	1
12	Plunger Knob	101 1120 00	1
13	Pin	513 1043 00	1
14	Tilt Bracket and Trunnion Bearing Complete with Y88, Y114 & Y227	352 4061 00	1
15	Key	502 7888 00	1
16	Tilting Pinion and Shaft	304 1061 20	2
17	Locking Plunger	513 1045 00	1
18	Tilt Wheel Stop Bracket Complete with Y11, Y112 & Y224	513 1044 00	1
19	Rubber Stop	502 9146 00	2
20	Tilt Wheel Stop Complete with Y171 & Y146	502 9144 00 502 9145 00	2 2 2 4

When Ordering
Always Quote

Machine N°, Part N°, Description and Quantity

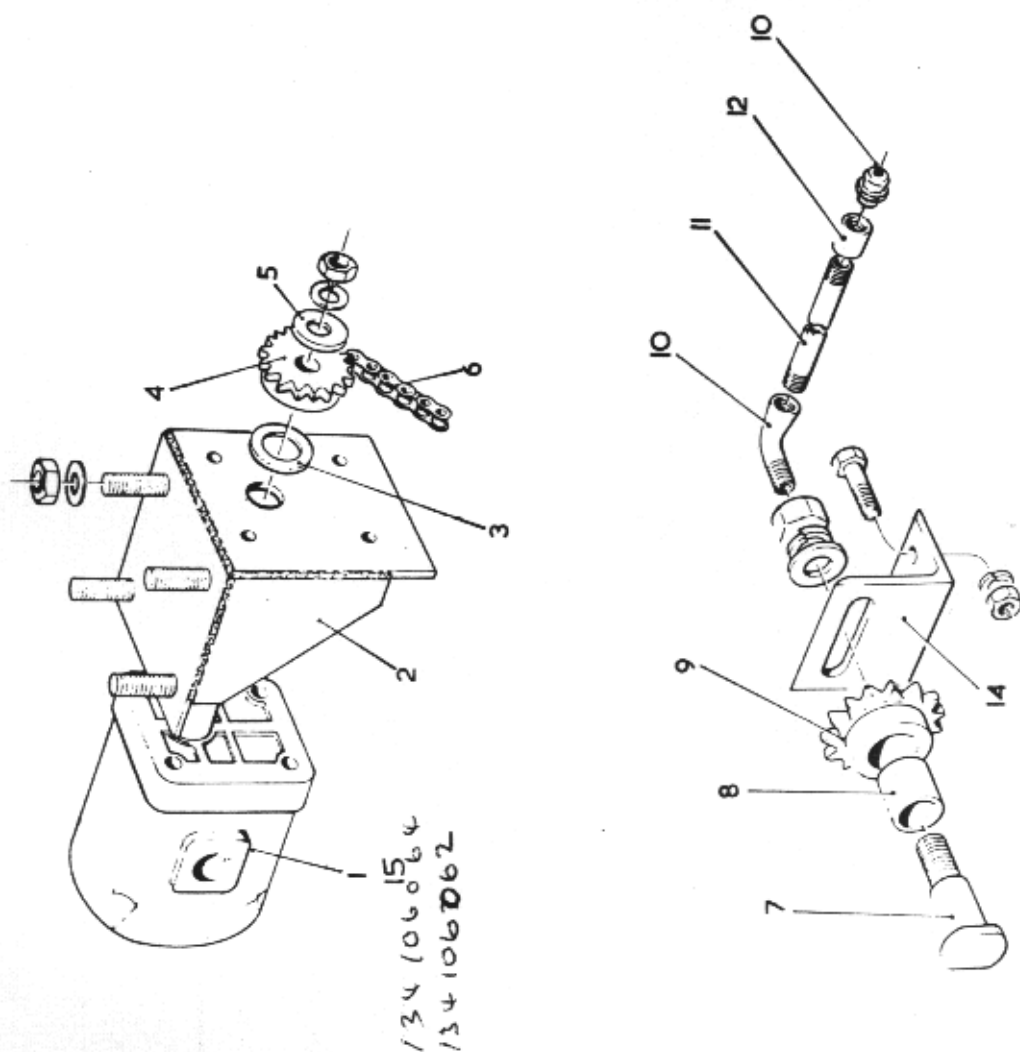

PUMP FIXING & JOCKEY ASSEMBLY

Ref	Description	Part No	Qty
1	Hydraulic Pump Complete with Y32, Y148 & Y237	361 1350 00	1
2	Pump Bracket Complete with Y146, Y216 & Y246	513 2083 00	1
3	Spacer	513 2084 00	4
4	Pump Sprocket	513 2085 00	1
5	Retaining Washer	513 2086 00	1
6	Complete with Y136 & Y225 Chain (for Lister ST1 and LR2 Drives)	134 1066 40	1
7	Chain (for Petter PH1 Drive) Jockey Pin Complete with Y115, Y229 & Y241	134 1066 20 513 1390 00	1
8	Jockey Sprocket Bush	503 0861 00	1
9	Jockey Sprocket	503 0503 00	1
10	Elbow	240 7010 00	1
11	Jockey Lubricator Extension (for Standard Machines)	503 0531 00	1
12	Socket (for Hoist Machines)	503 1970 00	1
13	Nipple	241 9010 00	1
14	Jockey Bracket Complete with Y19, Y113 & Y225	333 1022 00 503 0505 00	1
15	Hydraulic Pump Shaft Seal	365 8230 04	2
16	Hydraulic Pump Seal Kit (not illustrated)	365 8230 02	1
			SET

When Ordering Always Quote :- Machine No, Part No, Description and Quantity

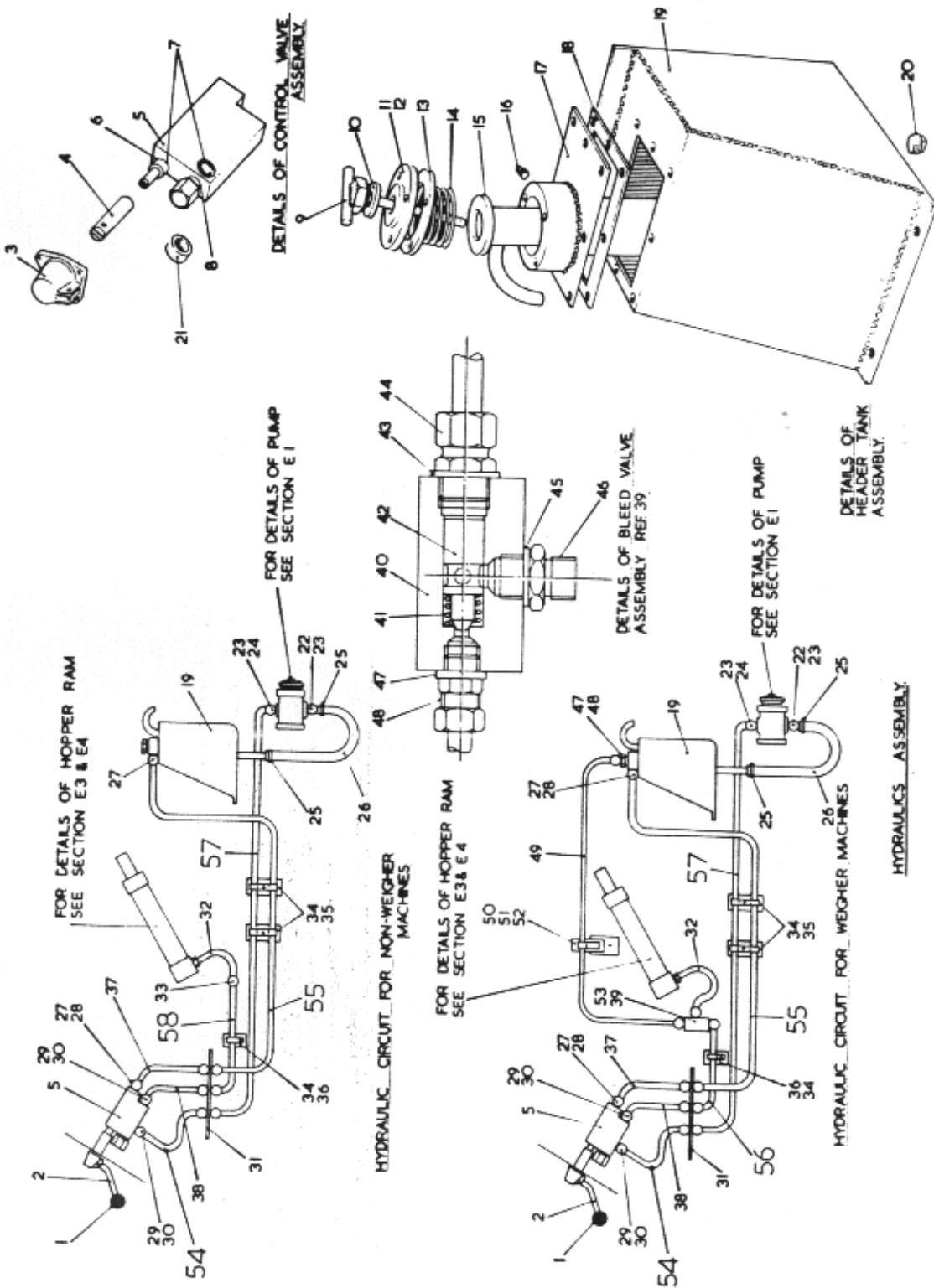

Ref	Description	Part N°	Qty	Ref	Description	Part N°	Qty
1	Knob	307 1010 00	1	32	Hopper Ram Hose	260 4062 40	1
2	Control Lever	503 0494 00	1	33	Coupling	513 1195 00	1
3	Complete with Y3, Y145 & Y237		1	34	Pipe Clip Block	503 0935 00	3
4	Control Lever Bearing	503 0510 00	1	35	Clip for Return and Pressure Pipe	503 0934 00	2
5	Complete with Y1, Y110 & Y237		3	36	Complete with Y12, Y112 & Y224		2
6	Control Valve Link	503 0493 00	1	37	Clip for Ram Steel Pipe	503 0933 00	1
7	Complete with Y2 & Y145		1	38	Complete with Y12, Y112 & Y224		1
8	Control Valve	020 1610 00	1	39	Hydraulic Pipe	513 2580 00	1
9	Complete with Y6, Y111 & Y223		2	40	Hydraulic Pipe	513 2581 00	1
10	Wiper Ring	417 7023 00	1	41	Bleed Valve Assembly Complete	503 0393 00	1
11	Wiper Ring	417 7024 00	2	42	Bleed Valve Body	503 1394 00	1
12	Seal	417 9570 00	2	43	Compression Spring	402 4280 00	1
13	Header Tank Dipstick	503 0561 00	1	44	Bleed Valve Plunger	503 1395 00	1
14	Seal	417 8080 00	1	45	Bonded Seal	417 8040 00	1
15	Filter Carrier Cap	503 0509 00	1	46	Coupling	446 3490 00	1
16	Complete with Y76		3	47	Bonded Seal	417 8030 00	1
17	Selon Washers	417 7170 00	3	48	Male Adaptor	013 1066 00	1
18	Gasket	503 0646 00	1	49	Bonded Seal	417 8020 00	2
19	Spring	423 3341 20	1	50	Coupling	141 1064 00	2
20	Tank Filter	503 0513 00	1	51	Nylon Pipe	110 9530 00	1
21	Taper Plug (Non-Weigher Machines only)		1	52	Support for Clip	504 4376 00	1
22	Header Tank Cover	241 7020 00	1	53	Pipe Clip	504 4375 00	1
23	Complete with Y74 & Y223	503 0904 00	1	54	Complete with Y12, Y112 & Y224		1
24	Header Tank Gasket		8	55	Pecking Block for Bleed Pipe	513 1324 00	1
25	Header Tank	503 0905 00	1	56	Securing Piece for Bleed Valve	503 1770 00	1
26	Complete with Y1, Y110 & Y222	503 0903 00	1	57	Hydraulic Pipe	513 2582 00	1
27	Plug		4	58	Hydraulic Pipe	513 2575 00	1
28	Valve Mounting Boss	241 7030 00	1		Hydraulic Pipe	513 2574 00	1
29	Stud Standpipe	503 0898 00	2		Hydraulic Pipe	513 2576 00	1
30	Seal	446 6600 00	1		Hydraulic Pipe	513 2573 00	1
31	Coupling	417 8060 00	2				
	Coupling	446 6120 00	1				
	Clip	132 1010 00	2				
	Moulded Hose	513 2041 00	1				
	Coupling	446 6310 00	2				
	Bonded Seal	417 8030 00	2				
	Coupling	446 3400 00	2				
	Bonded Seal	417 8020 00	2				
	Pipe Header	513 1173 00	1				
	Complete with Y10, Y112 & Y224		2				

* These items are used on machines with weigher only

When Ordering
Always Quote

Machine N° , Part N°, Description and Quantity

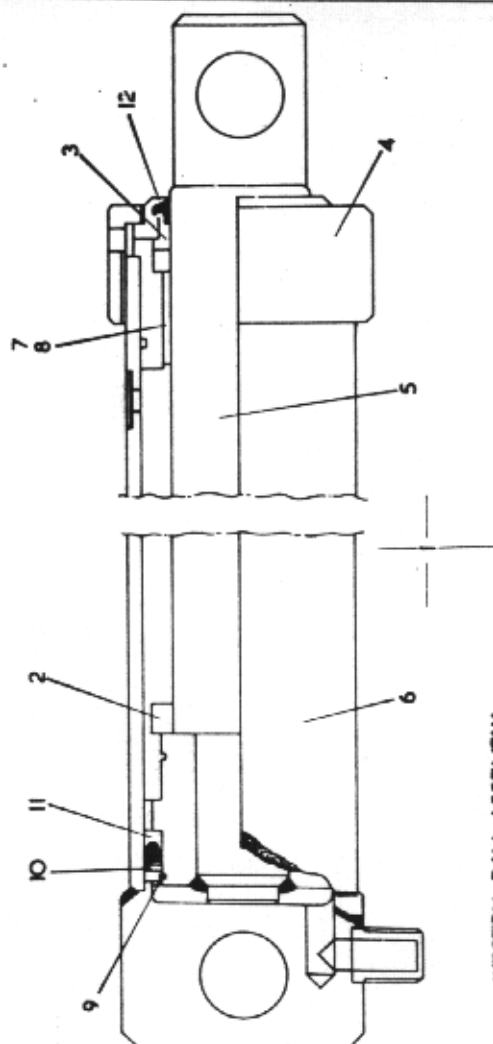

Ref	Description	Part No	Qty
1	Weston Ram Complete	272 1020 00	1
2	Collar	272 1020 01	1
3	Housing Assembly	272 1020 02	1
4	End Cap	272 1020 03	1
5	Piston Rod Assembly	272 1020 04	1
6	Ram Cylinder Assembly	272 1020 05	1
7	End Bearing	272 1020 06	1
8	End Bearing Assembly	272 1020 07	1
9	Spring Ring	272 1020 08	1
10	Washer	272 1020 09	1
11	Pressure Seal	272 1020 10	1
12	Wiper Seal	272 1020 11	1

When Ordering
Always Quote :-

Machine N°, Part N°, Description and Quantity

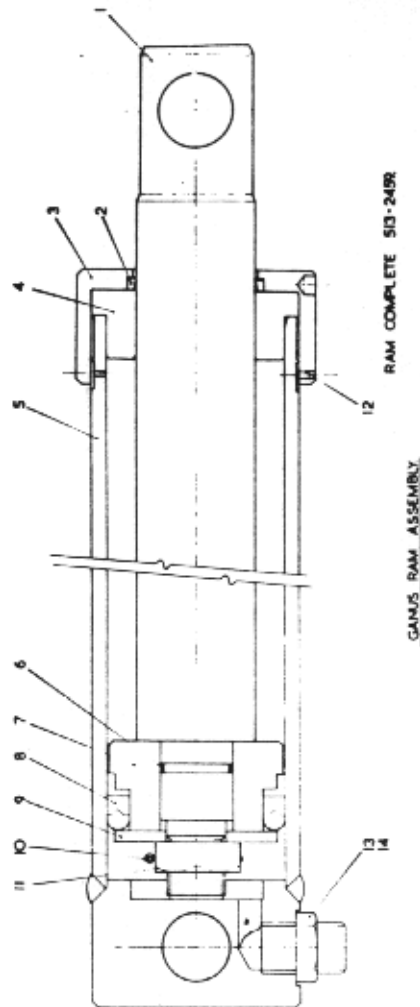

Ref	Description	Part No	Qty
1	Piston Rod	272 1270 18	1
*2	Wiper Seal	272 1270 09	1
3	Front Cap	272 1270 12	1
4	Front Insert	272 1270 13	1
5	Tube Assembly	272 1270 14	1
*6	'O' Ring	272 1270 10	1
7	Piston	272 1270 03	1
*8	Piston Seal Assembly	272 1270 08	1
9	Back up Plate	272 1270 06	1
10	Cotter Pin	272 1270 15	1
11	Nut	272 1270 16	1
12	Setscrew	272 1270 11	1
13	Coupling	446 6140 00	1
14	Bonded Seal	417 8040 00	1
<p>These Rams are number stamped 8200 and onwards</p>			
<p>* These Items can be bought in Kit Form - Ram Seal Kit, Part Number 272 1270 17</p>			

When Ordering :- Always Quote Machine N°, Part N°, Description and Quantity

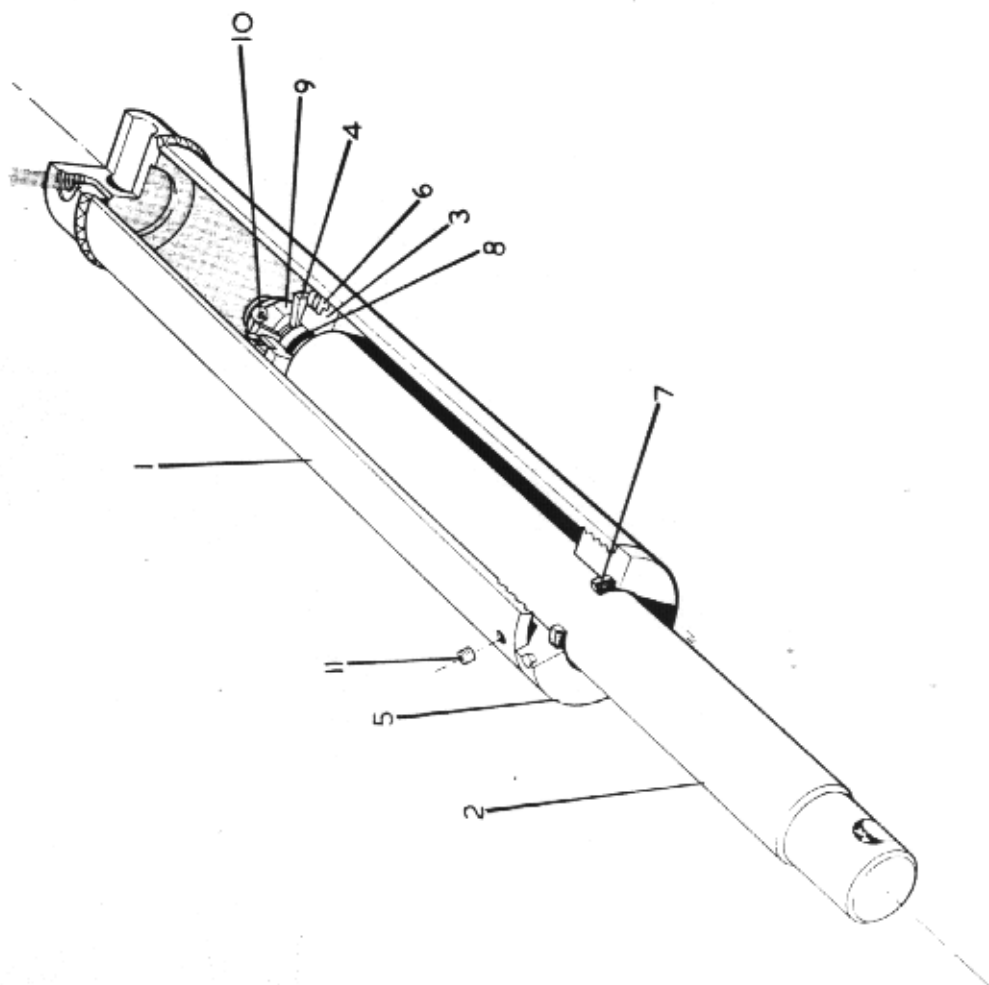

Ref	Description	Part No	Qty
1	Tube Assembly	272 1350 01	1
2	Piston Rod	272 1350 02	1
3	Piston Head	272 1273 00	1
4	Back up Plate	272 1276 00	1
5	Front End	272 1400 03	1
6	Piston Seal	272 1278 00	1
7	Wiper Seal	272 1279 00	1
8	'O' Ring	272 1270 10	1
9	Nut	272 1270 16	1
10	Split pin	272 1270 15	1
11	Screw	272 1400 04	1

TO IDENTIFY THIS TYPE OF CYLINDER THE LETTER 'B' IS STAMPED ON THE FREE END OF THE PISTON ROD.

For complete hopper ram assembly comprising all items listed above order Part No. 272 1350 00

NOTE: Items 6, 7 & 8 can be bought in kit form - Ram Seal Kit - Part No. 272 1270 17.

When Ordering :- Machine N°, Part N°, Description and Quantity
 Always Quote :-

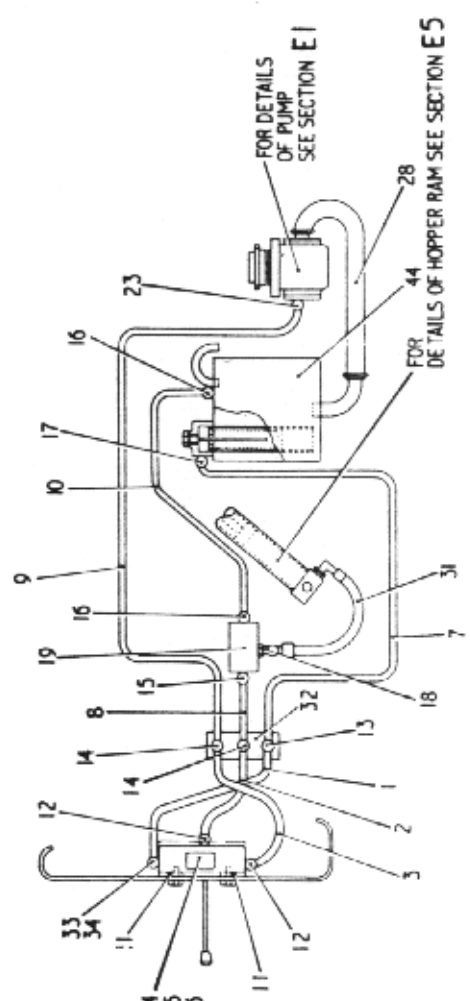
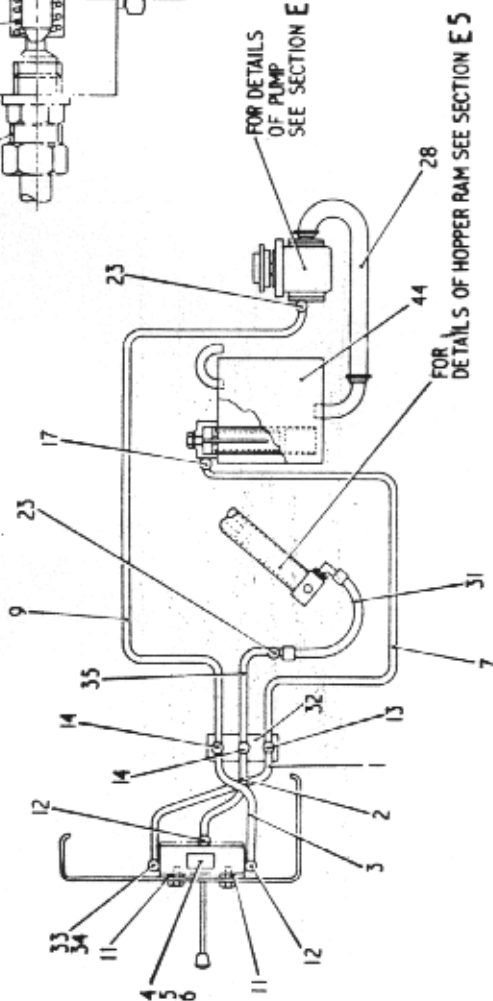
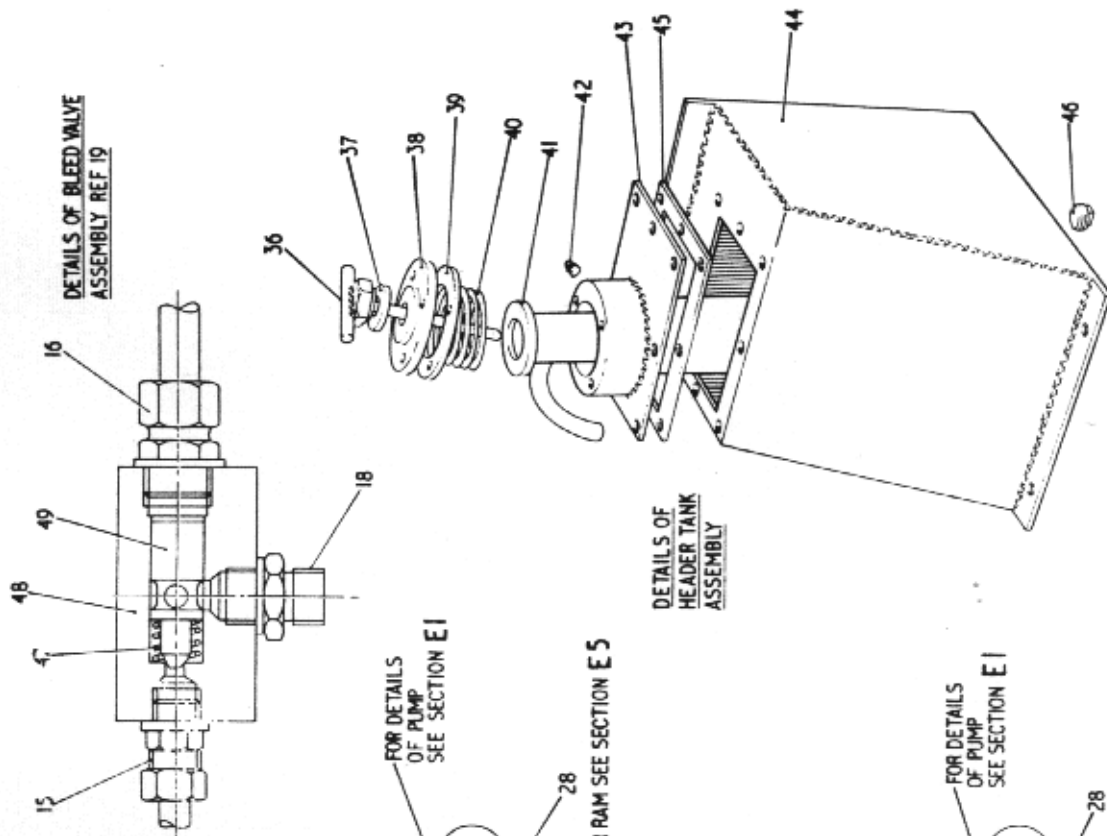

Ref	Description	Part N°	Qty	Ref	Description	Part N°	Qty
1	Hydraulic Hose	513 2916 00	1	32	Pipe Header Plate	513 2921 00	1
2	Hydraulic Hose	513 2915 00	1	33	Male Adaptor (Ref 4 only) complete with: Bonded Seal	446 6620 00	1
3	Hydraulic Hose	513 2917 00	1	34	Male Adaptor (Refs 5 & 6 only) complete with: Bonded Seal	417 8040 00	1
4	Control Valve Ref 451 4417 00	451 4417 00	1	35	Hydraulic Pipe	446 6140 00	1
5	Control Valve Ref 451 4426 00	451 4426 00	1	36	Header Tank Dipstick	417 8030 00	1
6	Control Valve Ref 451 4425 00	451 4425 00	1	37	Seal	513 2573 00	1
	4, 5 & 6 each complete with Y97 and Y234		2	38	Filter Carrier Cap complete with: Y76	503 0561 00	1
7	Hydraulic Pipe	513 2575 00	1	39	Gasket	417 7170 00	3
*8	Hydraulic Pipe	513 2574 00	1	40	Spring	503 0646 00	3
9	Hydraulic Pipe	513 2576 00	1	41	Tank Filter	423 3341 00	1
*10	Nylon Pipe	110 9530 10	1	42	Taper Plug (non weigher M/C only)	503 0513 00	1
11	Spacer (for Refs 5 & 6 only)	513 2918 00	2	43	Header Tank Cover complete with: Y74 & Y223	241 7020 00	1
12	Male Adaptor complete with: Bonded Seal	446 6110 00	2	44	Header Tank	503 0904 00	1
13	Bulkhead Connector	446 4870 00	2	45	complete with: Y1, Y110 & Y222	503 0903 00	8
14	Bulkhead Connector	446 4880 00	2	46	Header Tank Gasket	503 0905 00	1
*15	Coupling complete with: Bonded Seal	141 1064 00	1	47	Plug	241 7030 00	1
*16	Coupling complete with: Bonded Seal	446 3490 00	2	*48	Compression Spring	402 4280 00	1
17	Coupling complete with: Bonded Seal	446 3210 00	1	*49	Bleed Valve Body	503 1394 00	1
*18	Coned Adaptor complete with: Bonded Seal	417 8030 00	1	*	Bleed Valve Plunger	503 1395 00	1
*19	Bleed Valve Assembly complete	013 1066 00	1		These items are used on machines with weigher only		
20		417 8030 00	1				
21		503 1393 00	1				
22							
23	Coupling complete with: Bonded Seal	466 6120 00	1				
24		417 8030 00	1				
25							
26							
27							
28	Moulded Hose complete with: Clip	513 2041 00	1				
29		132 1010 00	2				
30							
31	Hooper Ram Hose	260 4062 00	1				

3/34

 When Ordering
Always Quote

Machine N°, Part N°, Description and Quantity

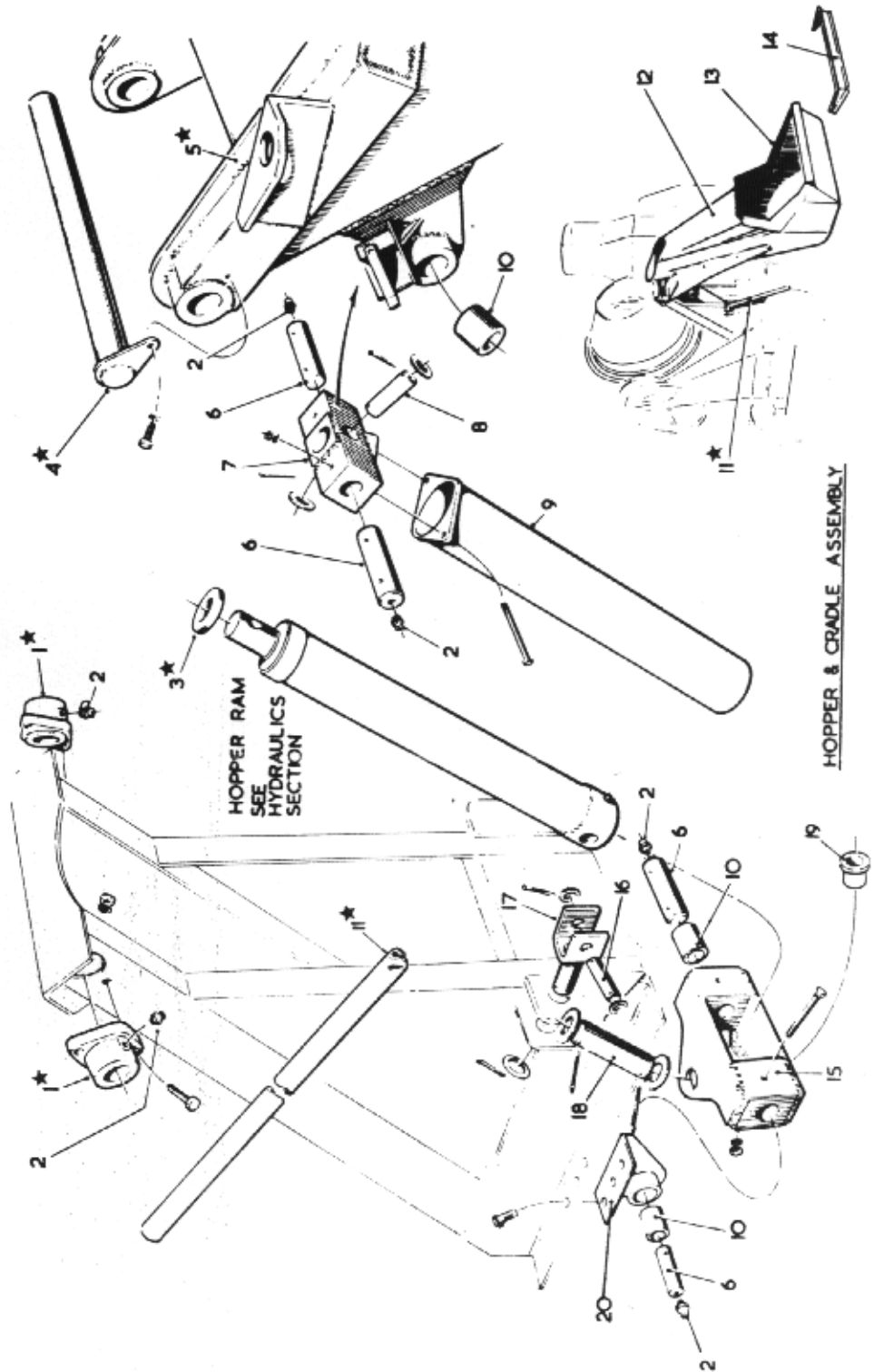

Ref	Description	Part N°	Qty
*1	Hopper Pivot Bearing Complete with Y23, Y113 & Y226	503 0519 00	2
2	Nipple	333 1022 00	4
*3	Rubber Buffer	503 0035 00	6
*4	Hopper Pivot Shaft Complete with Y81 & Y224	503 0518 00	1
*5	Hopper Cradle Complete with Y171, Y114, Y133 & Y239	503 0529 00	1
6	Ram Yoke Pin	503 0537 00	5
7	Upper Ram Yoke Complete with Y16, Y112 & Y224	503 0515 00	4
8	Upper Yoke Pin Complete with Y242 & Y261	503 0497 00	1
9	Ram Shroud	503 0496 00	2
10	Yoke Pin Bush	105 2100 00	1
11	Hopper Prop	503 0487 00	4
12	Hopper Cover Complete with Y10, Y112 & Y224	503 0791 00	1
13	Loading Hopper	503 0790 00	8
14	Hopper Extension (Optional)	503 0792 00	1
15	Lower Ram Yoke Complete with Y14, Y112 & Y224	503 0516 00	8
16	Hopper Prop Swivel Pin Complete with Y240 & Y258	502 8015 00	1
17	Hopper Prop Swivel	502 8013 00	2
18	Lower Yoke Pin (Weston Ram only) Complete with Y242 & Y261	503 0498 00	1
	Lower Yoke Pin (Ganus Ram only) Complete with Y261	513 2456 00	2
19	Lower Yoke Bush (Ganus Ram only)	513 2455 00	1
20	Hopper Ram Pivot Brackets Complete with Y45, Y121 & Y139	503 0041 00	2
			1RH
			1LH
			6

* These Items are only applicable to Non-Weigher Machines
See Group G1 for details of equivalent parts to suit Weigher Machines

When Ordering
Always Quote

Machine N° , Part N°, Description and Quantity

SO4451800

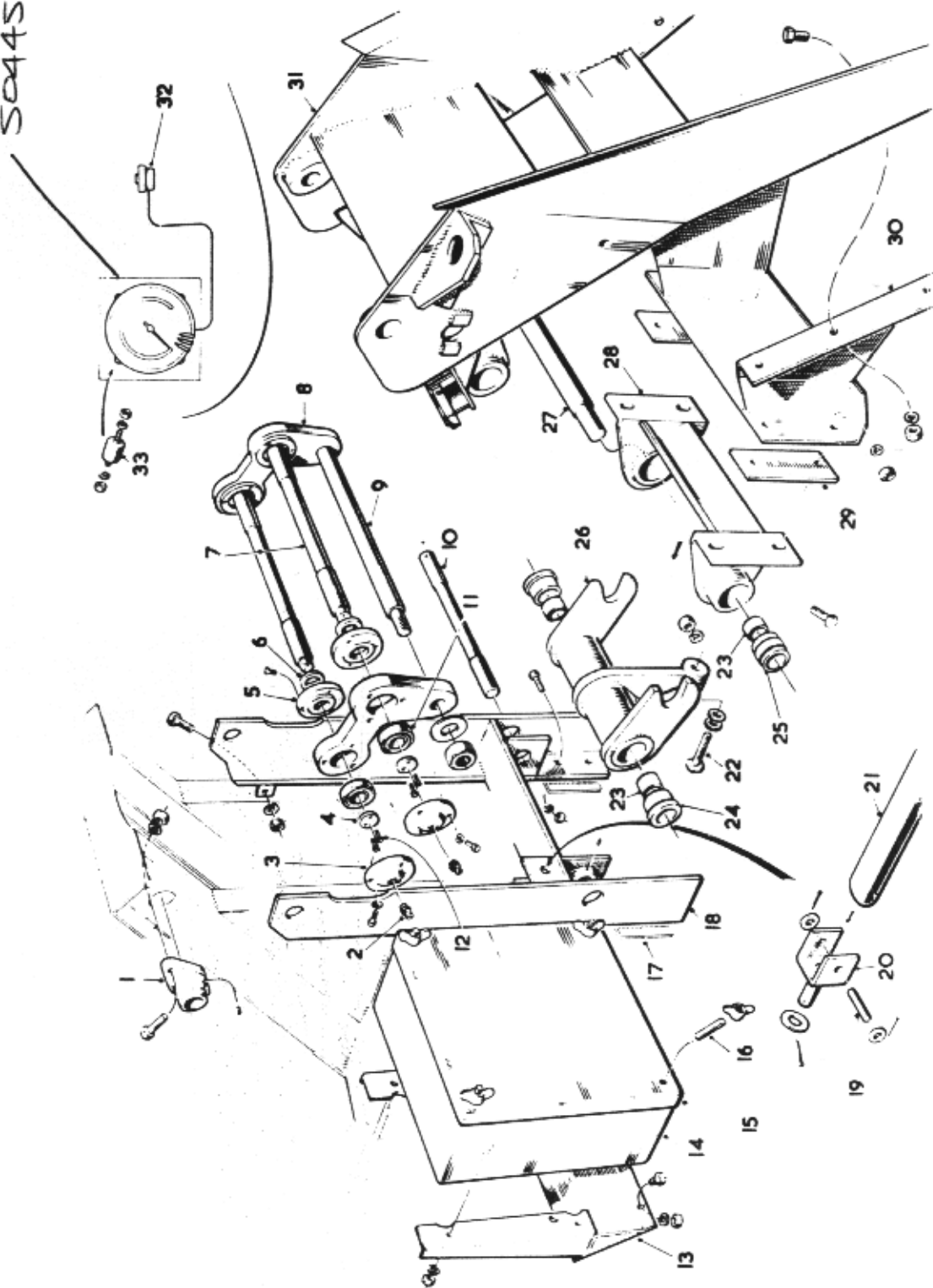

WEGING GEAR ASSEMBLY.

Ref	Description	Part No	Qty
1	Hopper Pivot Bearing Complete with Y23, Y113 & Y226 Y187	503 1163 00	2
2	Nipple	333 1020 20	4
3	Bearing Cap	503 1162 00	2
4	Complete with Y75 & Y223		4
5	Bearing Retainer	503 1160 00	4
6	Seal Housing	503 1161 00	4
7	Complete with Y170		12
8	Seal	417 7030 00	4
9	Hopper Pivot Shaft	503 1165 00	4
10	Upper Link	503 1166 00	2
11	Top Link Spacer	503 1164 00	2
12	Complete with Y122 & Y242		1
13	Lower Arm Pivot Shaft	503 1206 00	2
14	Bearing	113 1250 00	1
15	Special Screw	501 8770 00	4
16	Mounting Bracket for Gauge Box Complete with Y85 & Y226	503 1574 00	8
17	Gauge Mounting Box	504 5539 00	1
18	Complete with Y10, Y112 & Y224		4
19	Gauge Box Cover	504 5541 00	1
20	Stud for Gauge Box	504 5596 00	4
21	Complete with Y271 & Y246		4
22	Weighing Frame Packing Plates	504 4212 00	1
23	Weighing Frame	504 4211 00	SET
24	Complete with Y10, Y112, Y224 & Y186 Y21, Y113 & Y226		1
25	Hopper Prop Swivel Pin	502 8015 00	2
26	Complete with Y240 & Y258		4
27	Hopper Prop Swivel	502 8013 00	1
28	Hopper Prop	504 4880 00	2
29	Striking Button	503 1507 00	1
30	Complete with Y114 & Y227 Y239		1
31	Nylon Bush	114 6180 00	2
32	Pivot Arm Insert	513 2359 00	8
33	Cradle Bracket Insert	513 2360 00	2
34	Lower Arm Pivot	503 1207 00	2

 When Ordering
Always Quote

Machine No, Part No, Description and Quantity

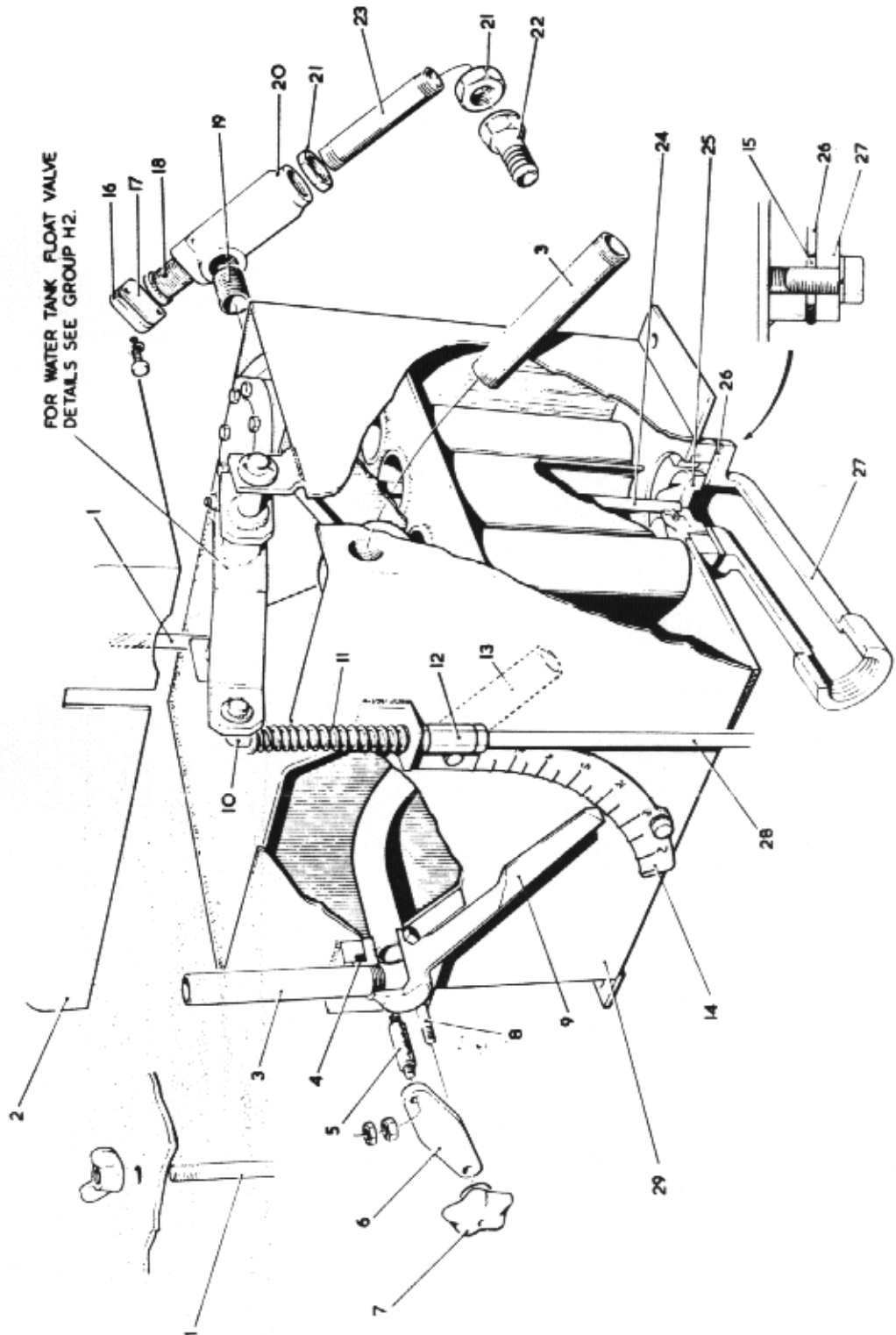

WATER TANK ASSEMBLY

Ref	Description	Part N°	Qty
1	Cover Stud	502 8164 00	1
2	Complete with Y271		1
3	Tank Cover	502 8111 00	1
4	Air Pipe Extension	502 8133 00	2
5	Rubber Sealing Ring	502 8107 00	1
6	Distance Piece	502 8165 00	1
7	Clamp Stirrup	502 8102 00	1
8	Locking Handle	502 8105 00	2
9	Complete with Y113 & Y132 Indicator (used with individual gallon and litre scales) Indicator (used with dual gallon and litre scale)	502 8109 00	1
10	Operating Link	555 1646 00	1
11	Complete with Y238 & Y257	502 8127 00	1
12	Compression Spring	424 2104 70	1
13	Connector	502 8134 00	1
14	Complete with Y132	502 8134 00	2
15	Air Pipe	502 8117 00	1
16	Tank Scale (Gallons)	502 8155 00	1
17	Tank Scale (Litres)	513 1775 00	1
18	Tank Scale (Gallons/Litres)	555 1645 00	1
19	All Complete with Y81 & Y246		2
20	Distance Washer	502 8849 00	3
21	Strainer Body Cap	502 9175 00	1
22	Complete with Y77 & Y223		2
23	Strainer Cap Gasket	502 9177 00	1
24	Strainer Element	502 9174 00	1
25	Nipple	241 4061 20	1
26	Strainer Body	502 9172 00	1
27	Back Nut	240 1060 00	2
28	Hose Connector	130 3060 00	1
29	Water Supply Pipe	502 8583 00	1
30	Valve Rod	513 1153 00	1
31	Complete with Y146		1
32	Outlet Valve	502 8103 00	1
33	Complete with Y259		1
34	Valve Seat	502 8071 00	1

When Ordering
Always Quote

Machine N° , Part N°, Description and Quantity

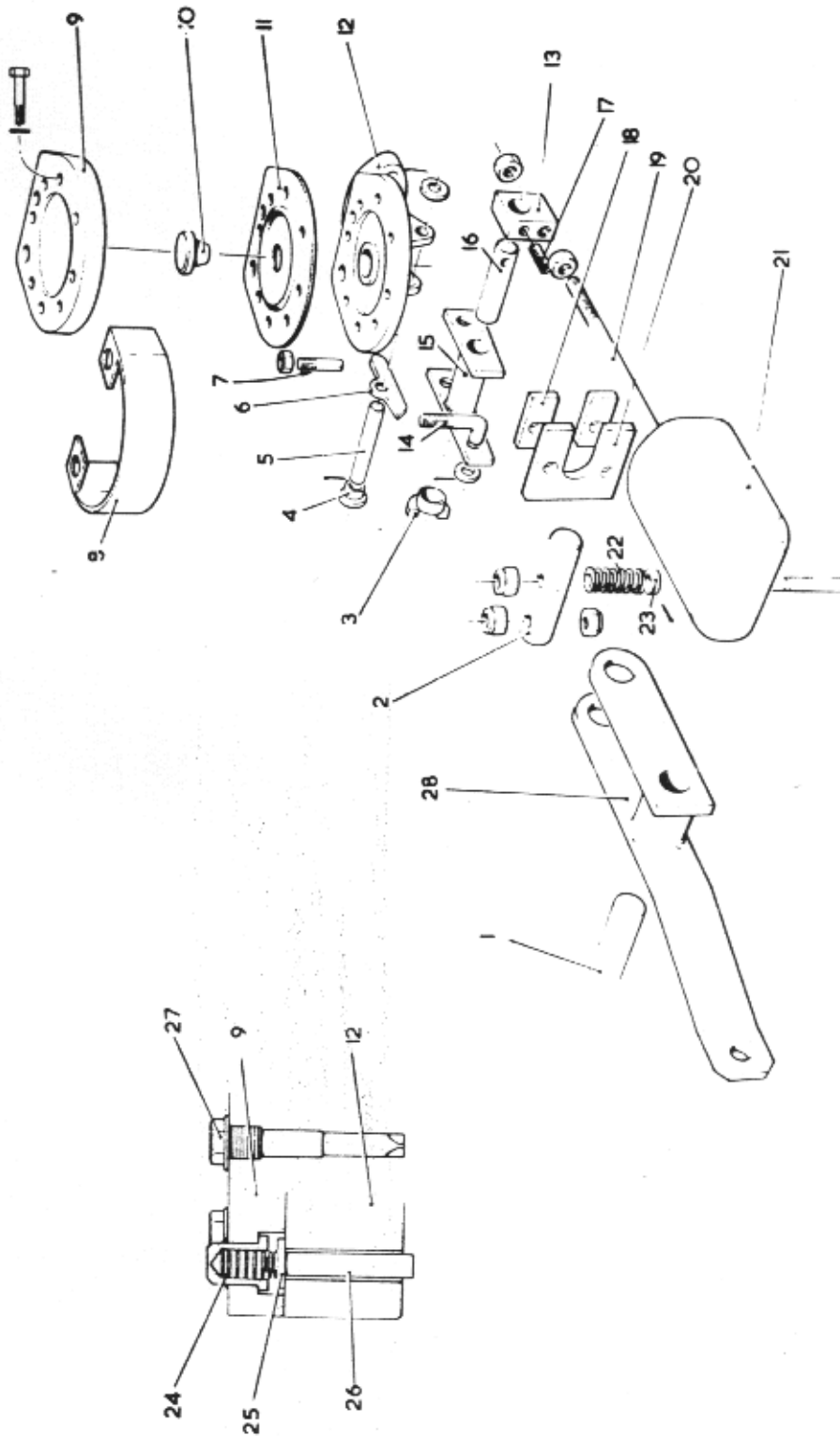

WATER TANK FLOAT VALVE DETAILS.

Ref	Description	Part N°	Qty	Ref	Description	Part N°	Qty
1	Operating Lever Pin	502 8130 00	1				
2	Complete with Y240 & Y258		4				
3	Operating Pin	502 8131 00	1				
4	Cam	502 8096 00	1				
5	Trip Lever Bush	502 9272 00	1				
6	Reset Lever Pin	502 8095 00	1				
7	Complete with Y246 & Y257		2				
8	Trip Lever	502 9271 00	1				
9	Stop Pin	502 8122 00	1				
10	Complete with Y130		1				
11	Splash Guard	502 8682 00	1				
12	Float Valve Top Cover	503 0685 00	1				
13	Complete with Y73 & Y276		8				
14	Diaphragm Centre	503 1533 00	1				
15	Diaphragm	503 1534 00	1				
16	Float Valve Body	503 0684 00	1				
17	Complete with Y81 & Y224		2				
18	Float Arm Fixing	502 8076 00	1				
19	Reset Link	502 0812 80	1				
20	Complete with Y246 & Y256		1				
21	Y146		2				
22	Reset Lever	502 9273 00	1				
23	Float Arm Pin	502 8097 00	1				
24	Y188		1				
25	Backing Strip	502 9902 20	2				
26	Float Arm	502 8099 00	1				
27	Complete with Y111		2				
28	Restrictive Plate	502 9902 10	1				
29	Complete with Y90, Y140 & Y222		2				
30	Polythene Float	220 3010 00	1				
31	Spring	420 1082 40	1				
32	Spring Collar	502 8125 00	1				
33	Complete with Y266		1				
34	Pilot Valve Spring	502 9276 00	1				
35	Pilot Valve Head	502 9163 00	1				
36	Pilot Valve Stem	502 9162 00	1				
37	Bleed Screw Complete	503 0689 00	1				
38	Operating Lever	502 8129 00	1				

When Ordering
Always Quote

Machine N°, Part N°, Description and Quantity

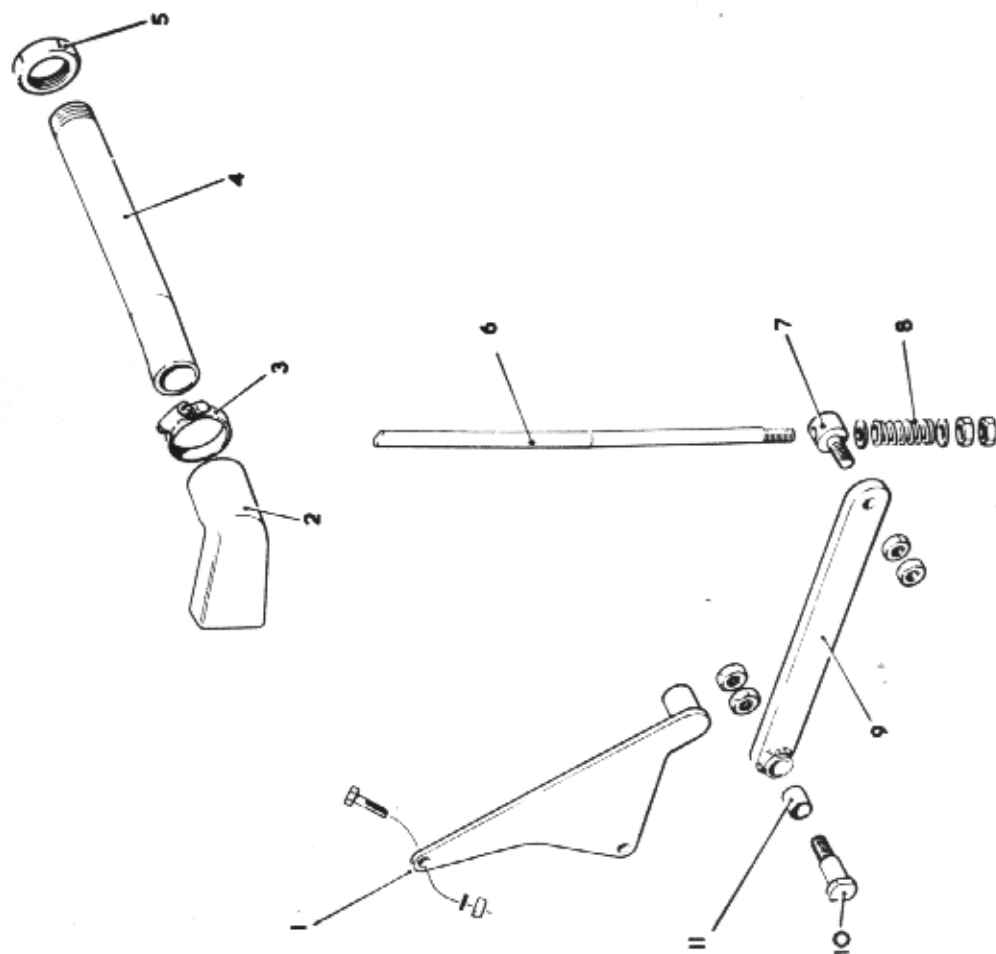

WATER TANK CONTROLS ASSEMBLY

Ref	Description	Part No	Qty
1	Trip Plate	502 7889 00	1
2	Delivery Pipe Nozzle	504 5315 00	1
3	Clip	132 1040 00	1
4	Delivery Pipe	504 5314 00	1
5	Backnut	240 1160 00	1
6	Connecting Rod	513 1081 00	1
7	Water Lever Pin	502 8051 00	1
8	Complete with Y132	423 6126 70	2
9	Spring	502 8053 00	1
10	Water Tank Lever	502 8106 00	1
11	Pivot Pin	105 4121 40	2
	Complete with Y132		1
	Bush		1

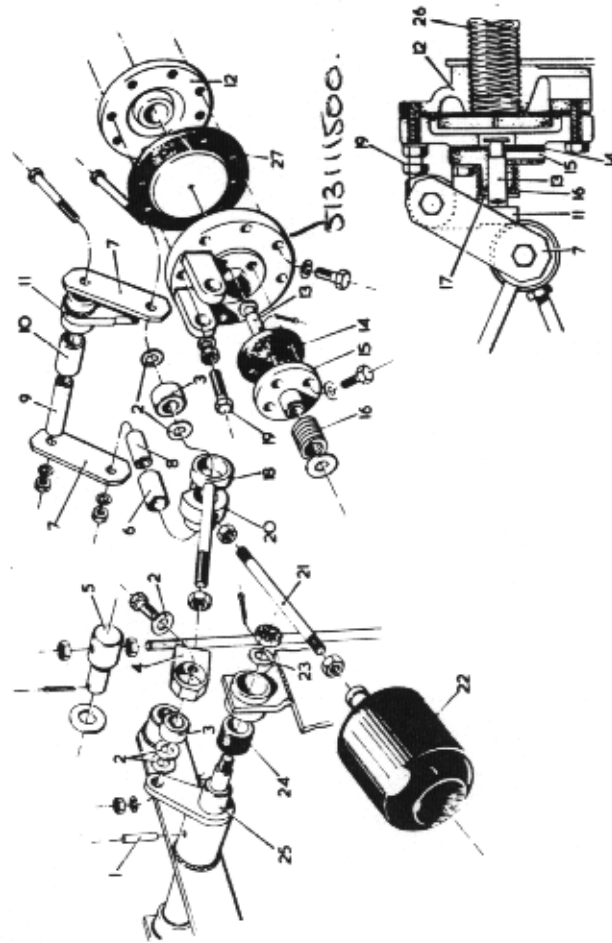

Water Tank Float Valve Details

Ref	Description	Part No	Qty
1	Taper Pin	352 1081 00	1
2	Washer (Reset Lever)	513 1125 00	5
3	Bearing	107 3060 00	2
4	Reset Link End	513 1134 00	1
5	Complete with Y50, Y111 & Y223	513 1132 00	1
6	Operating Pin	513 1127 00	1
7	Complete with Y238 & Y257	513 1136 00	2
8	Tufnol Bush (Cam)	513 1130 00	2
9	Distance Piece (Cam)	513 1138 00	1
10	Distance Piece (Trip Lever)	513 1126 00	1
11	Tufnol Bush (Trip Lever)	513 1128 00	1
12	Trip Lever	513 1116 00	1
13	Float Valve Body	513 1139 00	7
14	Complete with Y49 & Y276	513 1144 00	1
15	Pilot Valve	513 1143 00	1
16	Complete with Y257	513 1152 00	4
17	Pilot Valve Seat	513 1146 00	1
18	Pilot Valve Guide	513 1133 00	1
19	Complete with Y1 & Y276		1
20	Pilot Valve Spring	513 1149 00	1
21	Pilot Valve Washer	513 1135 00	1
22	Reset Link	220 3000 00	2
23	Complete with Y131		1
24	Complete with Y110 & Y276		1
25	Cam	513 1149 00	1
26	Float Arm	513 1135 00	1
27	Complete with Y141		2
28	Float		1
29	Washer (Operating Lever Shaft)	513 1131 00	2
30	Rubber Bush	513 1123 00	2
31	Operated Lever Shaft	513 1129 00	1
32	Complete with Y286 & Y257		2
33	Nipple	241 4031 20	1
34	Diaphragm Complete	513 1220 00	1

When Ordering :— Machine No, Part No, Description and Quantity
Always Quote

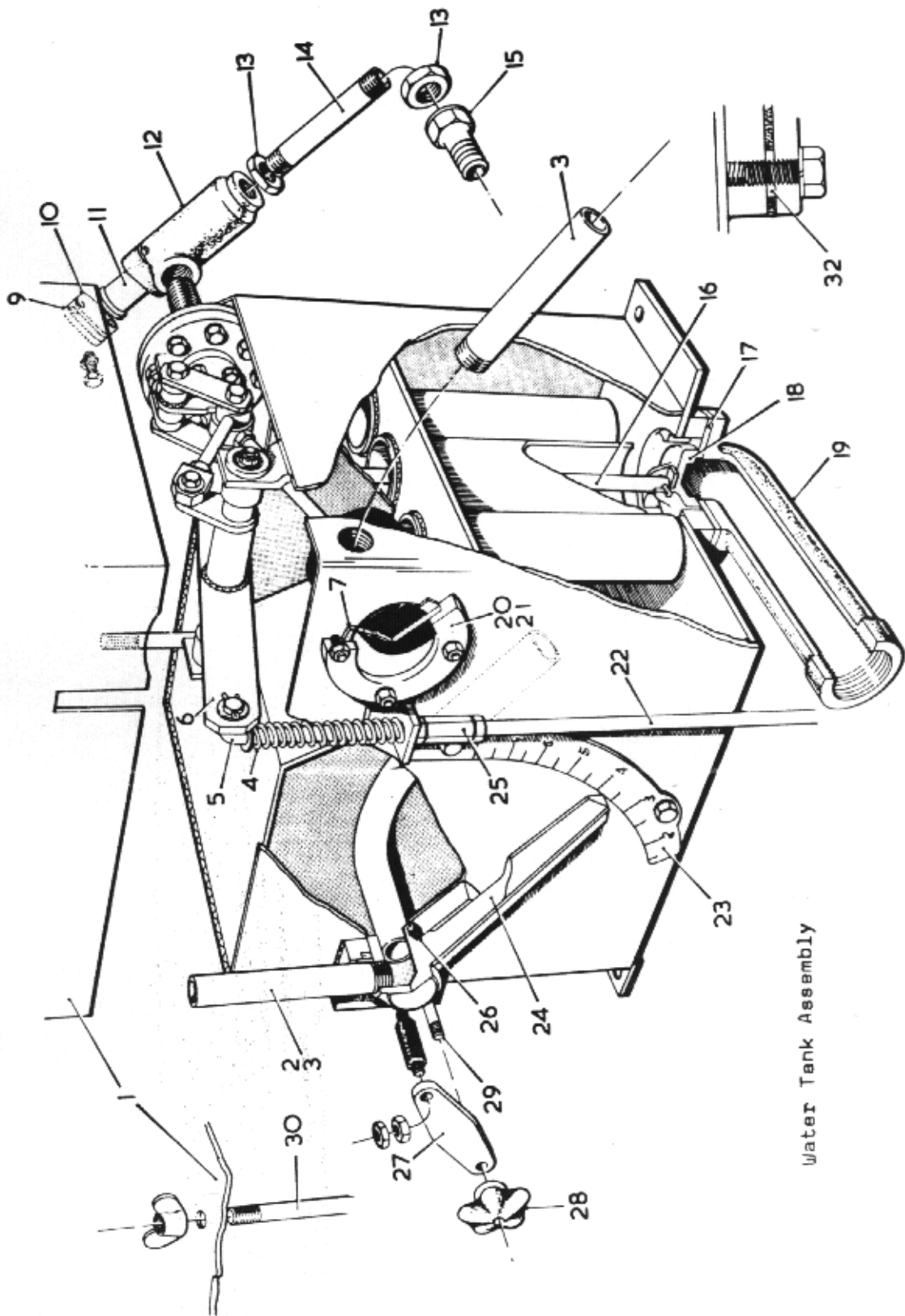

Water Tank Assembly

Ref	Description	Part N°	Qty
1	Water Tank Cover	513 1148 00	1
2	Air Pipe	502 8117 00	1
3	Air Pipe Extension	502 8133 00	2
4	Compression Spring	424 2104 70	1
5	Operating Link	502 8127 00	1
6	Complete with Y238 & Y257		1
7	Operating Lever	513 1147 00	1
8	Sight Glass	513 1120 00	1
9	Tank Body	513 1117 00	1
10	Strainer Body Cap	502 9175 00	1
11	Complete with Y77 & Y223		2
12	Strainer Cap Gasket	502 9177 00	1
13	Strainer Element	502 9174 00	1
14	Strainer Body	502 9172 00	1
15	Backnut	240 1060 00	2
16	Water Supply Pipe	502 8583 00	1
17	Hose Connection	130 3060 00	1
18	Valve Rod	513 1153 00	1
19	Complete with Y146 Y259		2
20	Valve Seat	502 8071 00	1
21	Outlet Valve	502 8103 00	1
22	Tank Outlet Connector	502 8681 00	1
23	Complete with Y86 & Y226		3
24	Sight Glass Seal	513 1121 00	1
25	Sight Glass Frame	513 1122 00	1
26	Complete with Y49, Y110, Y222 & Y276		4
27	Connection Rod	513 1081 00	1
28	Complete with Y132 & Y238		2
29	Tank Scale (Gallons)	502 8155 00	1
30	Tank Scale (Litres)	513 1775 00	1
31	Tank Scale (Gallons/Litres)	555 1645 00	1
32	All Complete with Y81 & Y246		2
33	Indicator (used with individual gallon and litre scales)	502 8109 00	1
34	Indicator (used with dual gallon and litre scale)	555 1646 00	1
35	Connector	502 8134 00	1
36	Complete with Y132		2
37	Rubber Sealing Ring	502 8107 00	1

When Ordering
Always Quote

Machine N°, Part N°, Description and Quantity

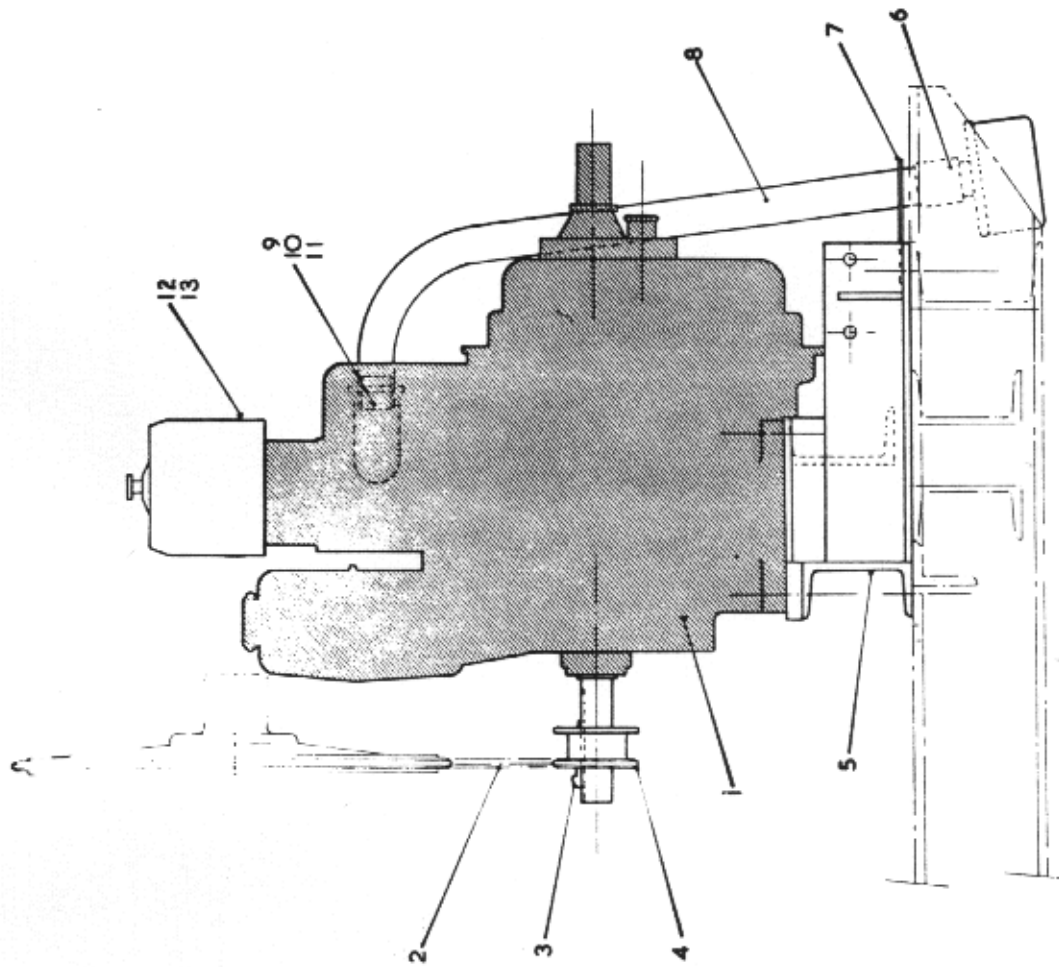

LISTER ST1 DRIVE ASSEMBLY.

Ref	Description	Part No	Qty
1	Lister ST1 Engine Complete with Y43 & Y40 Y147 & Y251	354 0530 00	1
2	Chain	134 1061 24	2
3	Key	300 1072 40	4
4	Engine Sprocket	503 1746 00	1
5	Engine Mounting Frame Complete with Y37 & Y38 Y93, Y147 & Y226 Y251	513 2129 00	1
6	Socket	241 9100 00	2
7	Exhaust Pipe Clip	513 2131 00	3
8	Exhaust Pipe	513 2130 00	1
9	Backnut	240 1100 00	1
10	Hexagon Exhaust Nipple	513 2584 00	1
11	Female Bend	240 3100 00	1
12	Manifold Adaptor Bush	513 2569 00	1
13	Purolator Air Cleaner	220 2850 00	1

When Ordering Always Quote :- Machine No, Part No, Description and Quantity

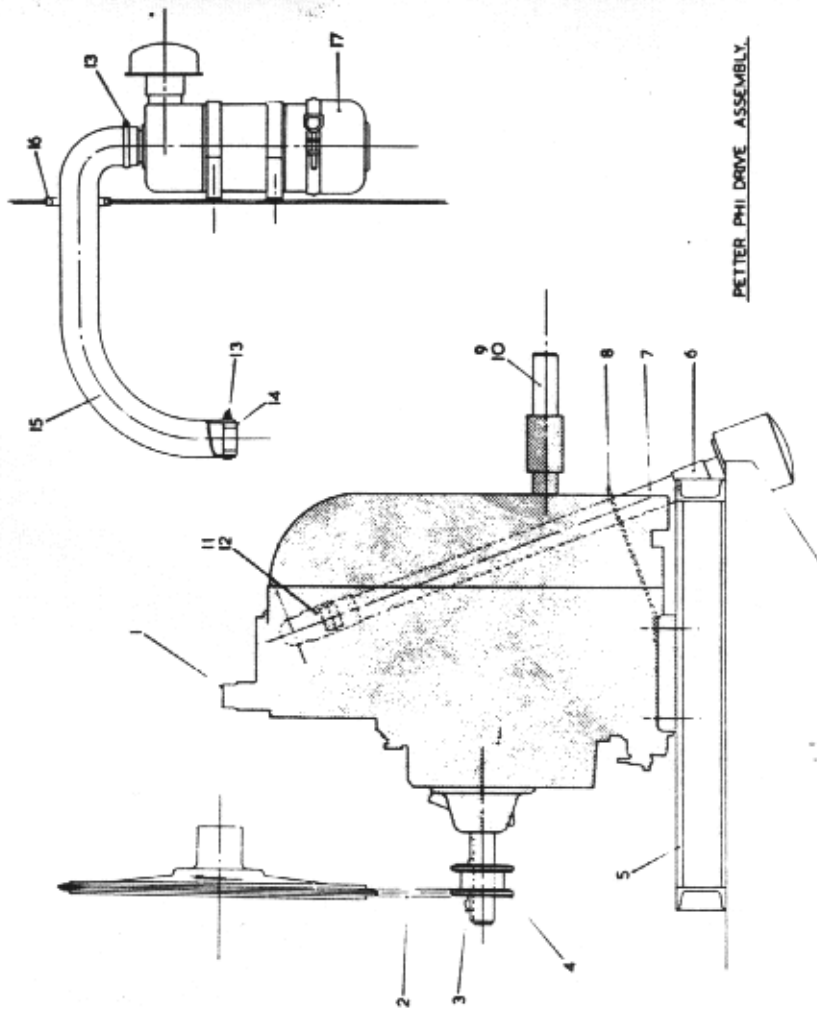

Ref	Description	Part No	Qty
1	Petter PH1 Engine Complete with Y41, Y147 & Y251	354 0540 00	1
2	Chain	134 1061 13	4
3	Key	300 1061 60	1
4	Engine Sprocket	503 0499 00	1
5	Engine Mounting Complete with Y39, Y147 & Y251	513 1162 00	1
6	Socket	241 9080 00	8
7	Exhaust Pipe	502 8606 00	1
8	Exhaust Pipe Clip	504 4879 00	1
9	Starting Shaft Extension Complete with Y70	502 8334 00	1
10	Key	304 1061 60	1
11	Elbow	240 7080 00	1
12	Nipple	243 9080 00	1
13	Clip	132 1200 20	2
14	Rubber Hose	260 5120 07	1
15	Flexflyte Hose	260 8322 40	1
16	Rubber Strip	394 4110 00	1
17	Cyclopac Air Cleaner Complete with Y5, Y11 & Y223	220 2290 00	1
			4

Refs. 13 to 17 inclusive used only when Cyclopac Air Cleaner is fitted

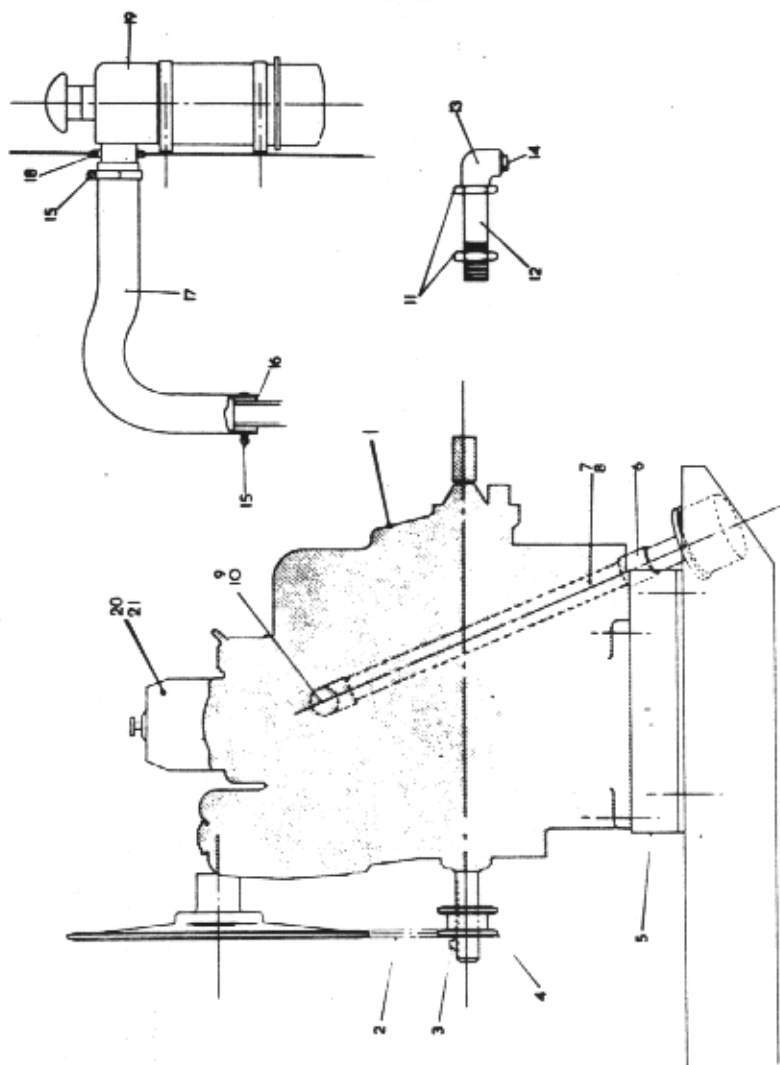

Lister ST2 Drive Assembly

Ref	Description	Part No	Qty
1	Lister ST2 Engine Complete with Y41 & Y147	354 0717 00	1
2	Chain	134 1061 24	4
3	Key	300 1072 40	1
4	Engine Sprocket	503 1746 00	1
5	Engine Mounting Complete with Y39 & Y147 Y251	503 1748 00	1
6	Socket	241 9100 00	4
7	Exhaust Pipe	241 9100 00	2
8	Exhaust Pipe Clip	503 1747 00	1
9	Elbow	504 4879 00	1
10	Nipple	241 1100 00	1
11	Backnut	243 9100 00	1
12	Oil Drain Extension Pipe	240 1030 00	2
13	Elbow	504 5023 00	1
14	Plug	241 1030 00	1
15	Clip	241 7030 00	1
16	Rubber Hose	132 1200 30	2
17	Convuluted Hose	260 5120 12	1
18	Rubber Strip	260 8323 00	1
19	Cyclopac Air Cleaner Complete with Y5, Y11 & Y223	394 4110 00	1
		220 2360 00	4

Refs. 15 to 19 inclusive used only when Cyclopac Air Cleaner is fitted

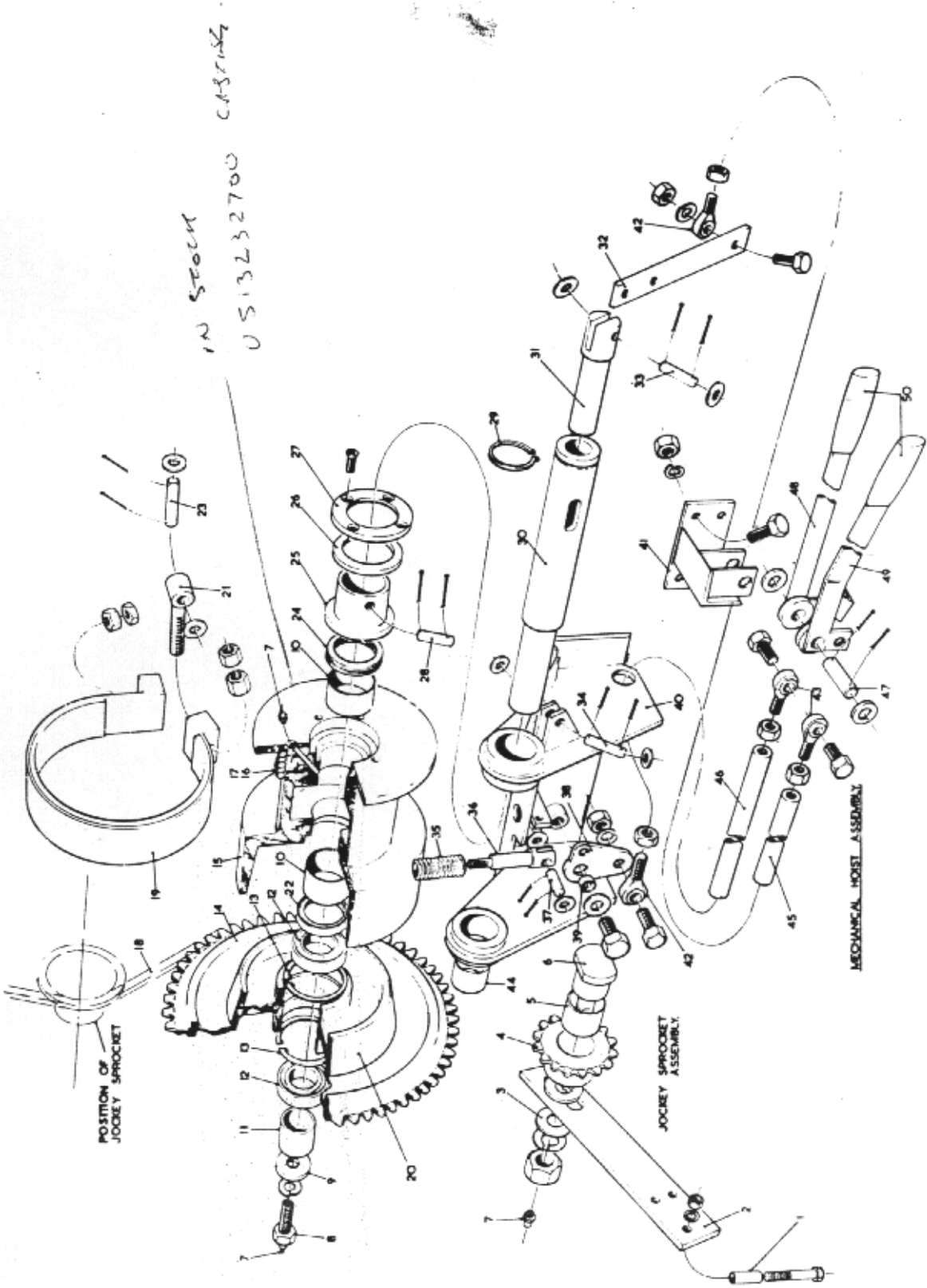

Ref	Description	Part N°	Qty
1	Distance Piece for Arm	513 2399 00	1
2	Jockey Support Arm	513 2398 00	1
3	Complete with Y25, Y113 & Y226		3
4	Jockey Washer	513 2386 00	2
5	Jockey Sprocket	513 2383 00	1
6	Bush	112 8031 00	1
7	Jockey Pin	513 2385 00	1
8	Complete with Y123 & Y231		1
9	Nipple	333 1020 20	3
10	Special Screw	513 2336 00	1
11	Complete with Y232		1
12	Retaining Washer	513 2337 00	1
13	Bush	112 8029 00	2
14	Locating Bush	513 2338 00	1
15	Bearing <i>88x118</i>	102 8280 20	2
16	Circlip	142 3190 00	2
17	Chainwheel and Clutch Cone	513 2328 00	1
18	Winding Drum	513 2327 00	1
19	Complete with Y206		2
20	Wire Rope	447 5590 00	1
21	Ball Bearing and Swivel Hook	477 3200 00	1
22	Chain	134 9111 22	1
23	Brake Band	513 2346 00	1
24	Clutch Lining Complete with Rivets	515 1010 00	1
25	Brake Adjuster	513 2419 00	1
26	Complete with Y120 & Y138		1
27	Oil Seal	417 1840 00	1
28	Brake Fixing Pin	513 2349 00	1
29	Complete with Y244 & Y626		2
30	Bearing	113 1640 00	1
31	Thrust Collar	513 2340 00	1
32	Thrust Pad	513 2354 00	1
33	Thrust Plate	513 2341 00	1
34	Complete with Y181		4
35	Operating Pin	513 2353 00	1
36	Complete with Y262		2
37	Circlip	142 3290 00	1
38	Main Shaft	513 2329 00	1
39	Operating Shaft	513 2333 00	1
40	Clutch Lever	513 2332 00	1

Ref	Description	Part N°	Qty
33	Operating Shaft Pin	513 2347 00	1
34	Complete with Y245 & Y263		2
35	Clutch Lever Pin	513 2348 00	1
36	Complete with Y245 & Y263		2
37	Disc Springs	420 4270 00	24
38	Brake Operating Rod	513 2344 00	1
39	Complete with Y120 & Y138		1
40	Fork End Pin	513 2351 00	1
41	Complete with Y244 & Y262		2
42	Brake Release Lever	513 2436 00	1
43	Complete with Y92 & Y241		1
44	Distance Piece	513 2345 00	1
45	Winch Bracket	513 2435 00	1
46	Complete with Y46, Y120 & Y230		7
47	Hand Lever Bracket	513 2443 00	1
48	Complete with Y92, Y120 & Y230		4
49	Rod End	383 2510 00	2
50	Complete with Y137, Y47, Y120 & Y230		2
51	Rod End	383 2510 00	2
52	Complete with Y91 & Y137		2
53	Bearing Spacer	513 2339 00	1
54	Brake Pull Rod	513 2437 00	1
55	Clutch Pull Rod	513 2438 00	1
56	Hand Lever Pin	513 2331 00	1
57	Complete with Y245 & Y263		2
58	Brake Control Lever	513 2439 00	1
59	Hoist Control Lever	513 2440 00	1
60	Hand Grips	264 7080 00	2

 When Ordering
Always Quote

Machine N° , Part N°, Description and Quantity

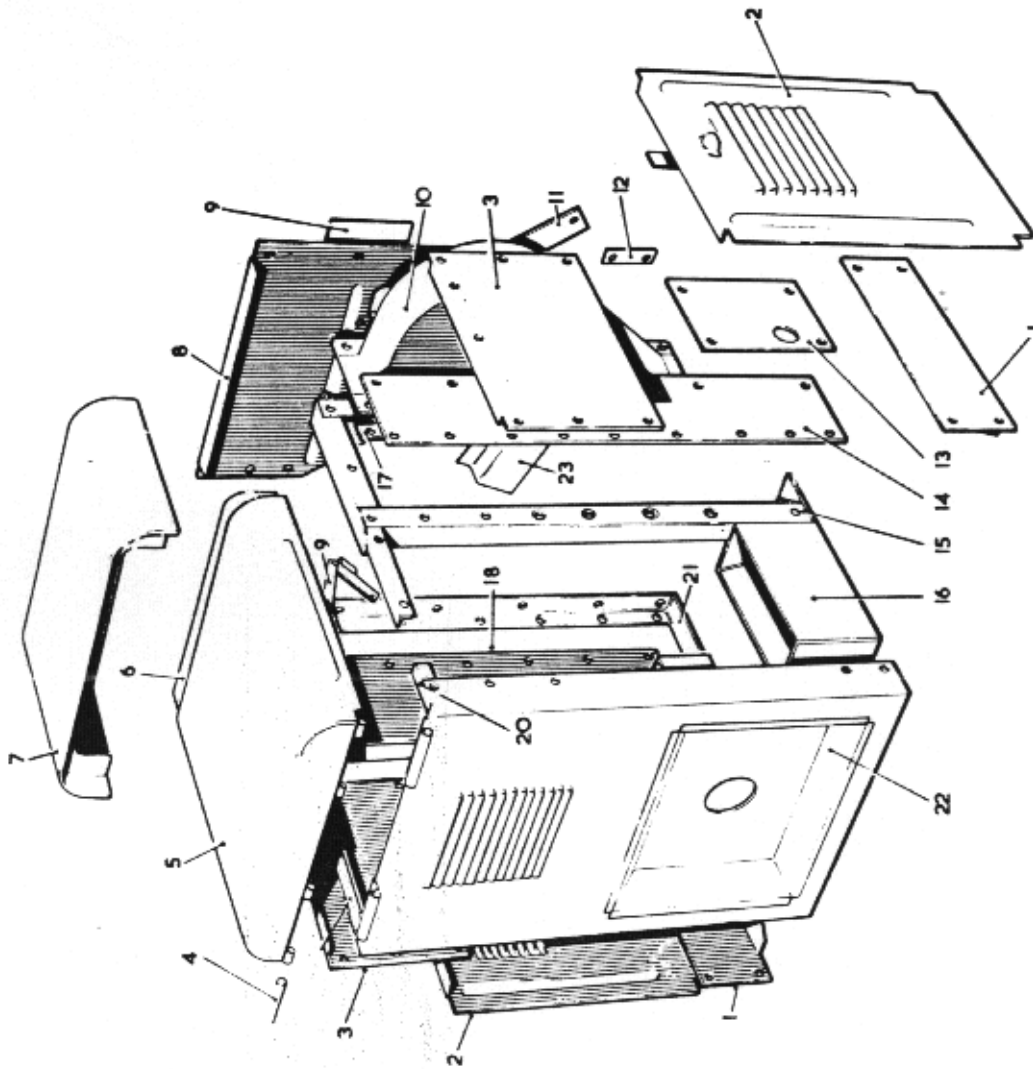

GUARDS ASSEMBLY FOR LISTER STI DRIVE.

Ref	Description	Part No	Qty
1	Housing Lower Side Plate Complete with Y8, Y112 & Y224	503 1075 00	2
2	Side Panel	503 1076 00	8
3	Housing Upper Side Plate Complete with Y8, Y112 & Y224	503 1082 00	2
4	Hinge Rod	502 8137 00	16
5	Complete with Y257	502 8104 00	1
6	Engine Top Cover	502 8089 00	1
7	Bridge Piece Complete with Y8, Y112 & Y224	503 1081 00	2
8	Water Tank Mounting Complete with Y10, Y112 & Y224	503 1083 00	6
9	Housing Rear Panel Complete with Y8, Y112 & Y224	503 1083 00	1
10	Blanking Plate	502 8589 00	7
11	Complete with Y8, Y112 & Y224	503 1073 00	2
12	Chain Wheel Guard	502 9765 00	1
13	Complete with Y8, Y112 & Y224	502 9765 00	3
14	Rear Panel Attachment Plate Complete with Y10, Y112 & Y224	502 9765 00	4
15	Rear Panel Retainer	502 9761 00	1
16	Complete with Y10, Y112 & Y224	502 8091 00	2
17	Jockey Guard	503 1079 10	1
18	Complete with Y78 & Y224	513 2074 00	4
19	Cover Plate	502 8360 00	1
20	Y180, Y112 & Y224	503 1080 00	4
21	Discharge Side Support Angle	503 1079 20	1
22	Complete with Y10, Y112 & Y224	502 8174 00	3
23	Tool Box		1
24	Complete with Y10, Y112 & Y224		2
25	Support Member		1
26	Charge Side Cover Plate		1
27	Complete with Y8, Y112 & Y224		8
28	Complete with Y180, Y112 & Y224		4
29	Engine Cover Stay		1
30	Complete with Y130 & Y237		4
31			1

When Ordering Always Quote : Machine No, Part No, Description and Quantity

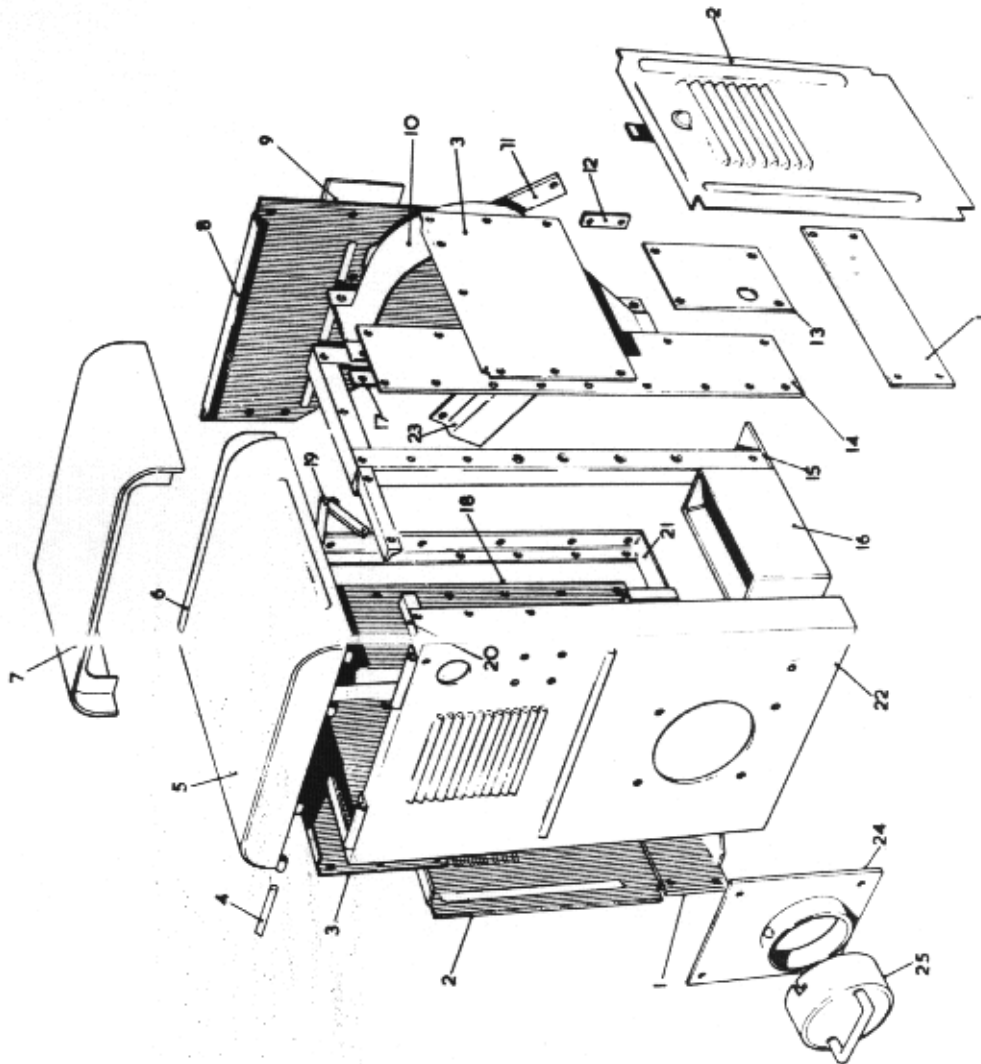

GUARDS ASSEMBLY FOR PETERET 11 DRIVE

Ref	Description	Part No	Qty	Ref	Description	Part No	Qty
1	Housing Lower Side Plate Complete with Y8, Y112 & Y224	503 1075 00	2	20	Housing Stiffening Angles	504 5503 00	1
2	Side Panel	503 1076 00	8	21	Charge Side Support Angle Completa with Y10, Y112 & Y224	503 1078 00	1
3	Housing Upper Side Plate Complete with Y8, Y112 & Y224	503 1082 00	2	22	Engine Front Guard	503 1074 00	3
4	Hinge Rod Complete with Y257	502 8137 00	2	23	Inner Chain Guard Complete with Y8, Y112 & Y224	513 1995 00	1
5	Engine Top Cover	502 8104 00	16	24	Crankshaft Guard Complete with Y7, Y112 & Y224	502 8108 00	4
6	Bridge Piece Complete with Y8, Y112 & Y224	502 8089 00	1	25	Cap for Crankshaft Extension	501 3983 00	1
7	Water Tank Mounting Complete with Y10, Y112 & Y224	503 1081 00	2				
8	Housing Rear Panel Complete with Y8, Y112 & Y224	503 1083 00	1				
9	Blanking Plate Complete with Y8, Y112 & Y224	502 8589 00	7				
10	Chain Wheel Guard Complete with Y8, Y112 & Y224	503 1073 00	2				
11	Rear Panel Attachment Plate Complete with Y10, Y112 & Y224	502 9765 00	1				
12	Rear Panel Retainer Complete with Y10, Y112 & Y224	502 9761 00	3				
13	Jockey Guard Complete with Y78 & Y224	502 8091 00	4				
14	Cover Plate Complete with Y180, Y112 & Y224	503 1079 10	1				
15	Discharge Side Support Angle Complete with Y10, Y112 & Y224	503 1077 00	4				
16	Tool Box Complete with Y10, Y112 & Y224	502 8360 00	1				
17	Support Member Charge Side Cover Plate	503 1080 00	2				
18	Complete with Y8, Y112 & Y224 Engine Cover Stay Complete with Y130 & Y237	503 1079 20	1				
19	Y3	502 8174 00	8				

When Ordering
Always Quote

Machine No, Part No, Description and Quantity

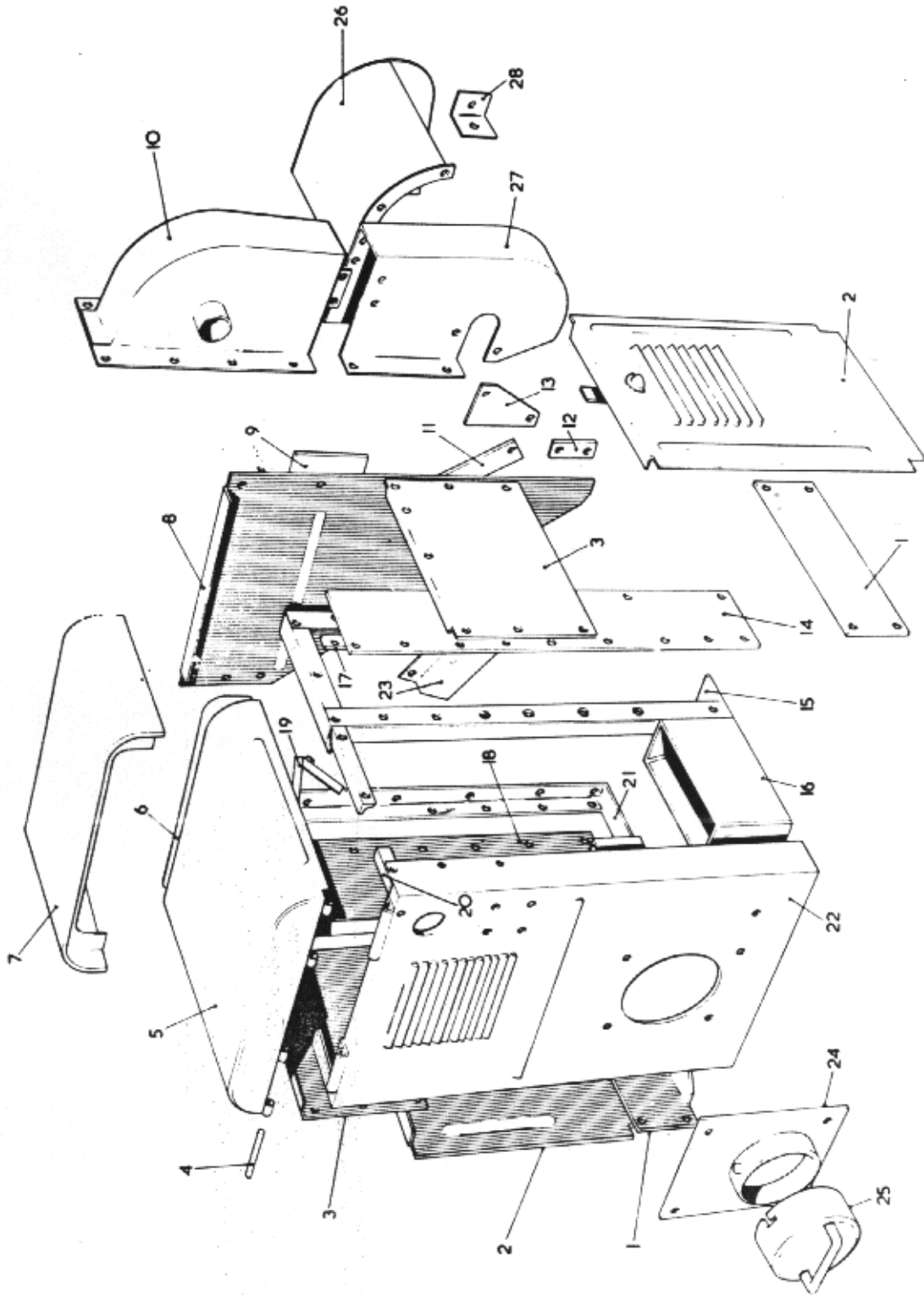

GUARDS ASSEMBLY FOR LISTER SR2 DRIVE
HOIST MACHINES ONLY.

When Ordering :-
Always Quote

Machine No, Part No, Description and Quantity

Ref	Description	Part N°	Qty	Ref	Description	Part N°	Qty
1	Housing Lower Side Plate	503 1075 00	2	20	Housing Stiffening Angles	504 5503 00	1
2	Complete with Y18, Y112 & Y224		8	21	Charge Side Support Angle	503 1078 00	1
3	Side Panel	503 1076 00	2	22	Complete with Y10, Y112 & Y224	503 1074 00	3
4	Housing Upper Side Plate	503 1082 00	2	23	Engine Front Guard	513 1995 00	1
5	Complete with Y8, Y112 & Y224		16	24	Inner Chain Guard	503 1769 00	1
6	Hinge Rod	502 8137 00	1	25	Complete with Y8, Y112 & Y224		4
7	Complete with Y257		2	26	Crankshaft Guard		1
8	Engine Top Cover	502 8104 00	1	27	Complete with Y7, Y112 & Y224		4
9	Bridge Piece	502 8089 00	1		Cap for Crankshaft Extension	501 3983 00	1
10	Complete with Y8, Y112 & Y224		2		Hoist Guard	513 2402 00	1
11	Water Tank Mounting	503 1081 00	1		Complete with Y74 & Y223	513 2401 00	3
12	Complete with Y10, Y112 & Y224		6		Chain Guard over Hoist		1
13	Housing Rear Panel	503 1083 00	1		Complete with Y74 & Y223		1
14	Complete with Y8, Y112 & Y224		7		Y79 & Y224		4
15	Blanking Plate		2		Y80, Y112 & Y224		2
16	Complete with Y8, Y112 & Y224		1		Y77, Y111 & Y223		1
17	Chain Wheel Guard	502 8589 00	2	28	Fixing Bracket	512 2384 00	1
18	Complete with Y80, Y112 & Y224		2		Complete with Y80, Y112 & Y224		2
19	Rear Panel Attachment Plates	513 2400 00	1				1
20	Complete with Y10, Y112 & Y224		4				4
21	Y79 & Y224		4				4
22	Rear Panel Retainer	502 9765 00	1				1
23	Complete with Y10, Y112 & Y224		3				3
24	Y79 & Y224		4				4
25	Complete with Y10, Y112 & Y224		1				1
26	Cover Plate	503 9761 00	2				2
27	Complete with Y74 & Y223		1				1
28	Complete with Y74 & Y223		2				2
29	Cover Plate	513 2460 00	1				1
30	Complete with Y180, Y112 & Y224		2				2
31	Discharge Side Support Angle	503 1079 10	1				1
32	Complete with Y10, Y112 & Y224		4				4
33	Tool Box	503 1077 00	1				1
34	Complete with Y10, Y112 & Y224		3				3
35	Support Member	502 8360 00	1				1
36	Charge Side Cover Plate	503 1080 00	2				2
37	Complete with Y8, Y112 & Y224		1				1
38	Engine Cover Stay	503 1079 20	1				1
39	Complete with Y130 & Y237		8				8
40	Y3	502 8174 00	4				4
41			1				1
42			4				4
43			1				1

When Ordering
Always Quote

Machine N°, Part N°, Description and Quantity

D.S.C. STARTER

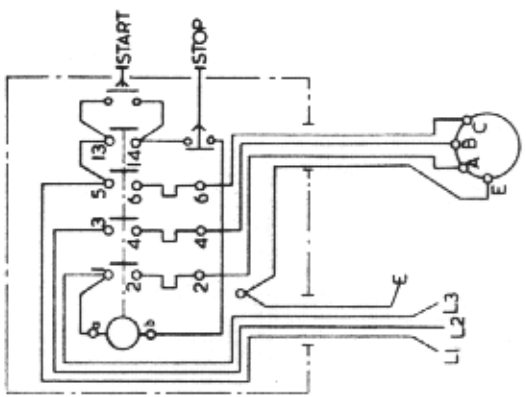
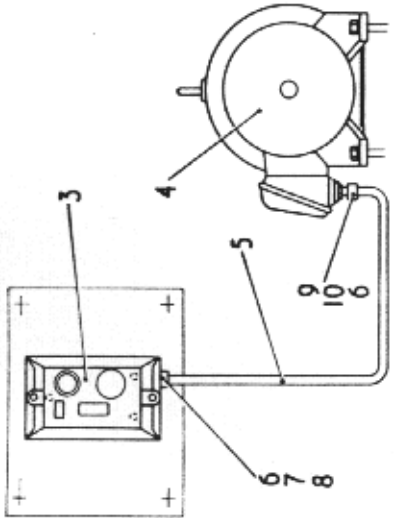

M.T.E. STARTER

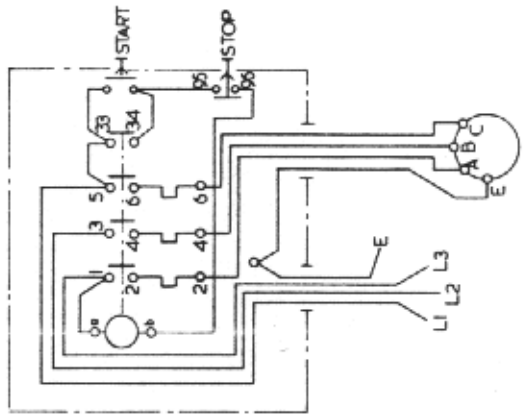
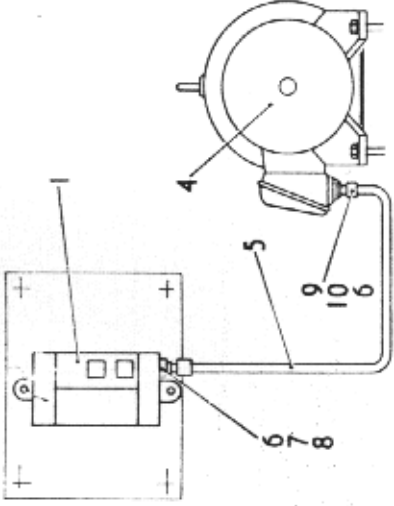

DANFOSS STARTER

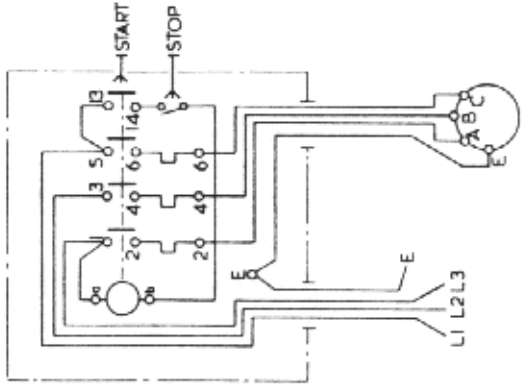
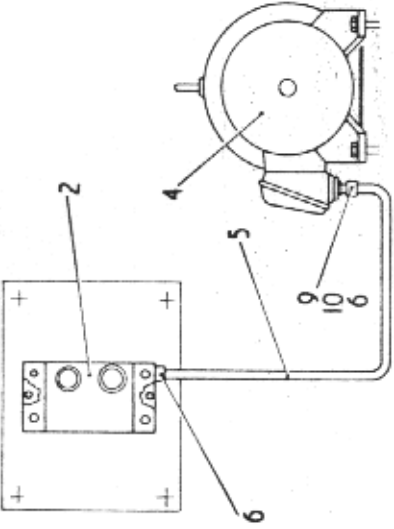

Ref	Description	Part N°	Qty
1	MTE Starter complete with: Case Contactor O/L Unit Y96, Y124 & Y233	208 3996 00 208 3985 20 192 9280 21 207 8180 22	1 1 1 1
2	Danfoss Starter complete with: Case Contactor O/L Unit Y290, Y124 & Y233	208 3987 00 208 3985 01 192 9280 03 207 8180 02	2 1 1 1
3	Dorman Smith Starter complete with: Case Contactor O/L Unit Y291, Y124 & Y233	208 3997 00 208 3985 40 192 9280 44 207 8180 43	1 1 1 1
4	Electric Motor 4 KW (5.5 HP) complete with: Y43, Y119 & Y226	202 4660 00	3
5	Pliable Conduit	131 7700 10	4
6	Coupling	131 2710 00	1
7	Locknut	133 2700 50	2
8	Brass Bush	131 3700 00	1
9	Reducing Socket (Newman Motor only)	131 5700 00	1
10	Reducing Socket (Brook Motor only)	131 5120 01	1

When Ordering
Always Quote

Machine N°, Part N°, Description and Quantity

Ref	Part N°	Ref	Part N°	Ref	Part N°
	Hex Hd Bolts	Y51	460 5050 22		Locknuts
Y1	460 5040 06			Y130	302 5040 00
Y2	460 5040 10			Y131	302 5060 00
Y3	460 5040 12			Y132	302 5080 00
Y4	460 5040 14			Y133	302 5100 00
Y5	460 5050 06			Y134	302 5240 00
Y6	460 5050 26			Y135	330 5506 00
Y7	460 5060 04	Y70	418 3504 03	Y136	330 5507 00
Y8	460 5060 06	Y71	418 3504 05	Y137	330 5508 00
Y9	460 5060 05	Y72	418 3504 06	Y138	330 6120 00
Y10	460 5060 08	Y73	418 3504 10	Y139	330 5510 00
Y11	460 5060 10	Y74	418 3505 04	Y140	330 5504 00
Y12	460 5060 12	Y75	418 3505 06	Y141	302 5050 00
Y13	460 5060 14	Y76	418 3505 07		
Y14	460 5060 16	Y77	418 3505 08		
Y15	460 5060 24	Y78	418 3506 03		
Y16	460 5060 26	Y79	418 3506 04		
Y17	460 5060 30	Y80	418 3506 05		
Y18	460 5060 52	Y81	418 3506 06		
Y19	460 5080 08	Y82	418 3506 08		Binx Nuts
Y20	460 5080 10	Y83	418 3506 12	Y145	335 7604 00
Y21	460 5080 12	Y84	418 3508 06	Y146	335 7606 00
Y22	460 5080 13	Y85	418 3508 08	Y147	330 3608 00
Y23	460 5080 14	Y86	418 3508 12	Y148	330 3604 00
Y24	460 5080 20	Y87	418 3508 14		
Y25	460 5080 44	Y88	418 3510 12		
Y26	460 5100 14	Y89	418 9600 60		
Y27	460 5100 16	Y90	418 2504 06		
Y28	460 5120 18	Y91	405 6120 30		
Y29	460 5160 16	Y92	405 6120 35		Skt Hd Capscrew
Y30	460 5160 18	Y93	418 2508 10	Y155	404 7504 32
Y31	460 5160 44	Y94	418 3504 12	Y156	404 7506 16
Y32	460 3504 11	Y95	418 3510 16	Y157	404 7041 00
Y33	460 3506 18	Y96	405 0050 25	Y158	404 7051 60
Y34	460 3506 20	Y97	405 0080 25	Y159	404 7061 60
Y35	460 3506 54				
Y36	460 3508 10				
Y37	460 3508 12				
Y38	460 3508 14	Y110	331 8504 00		
Y39	460 3508 16	Y111	331 8505 00		
Y40	460 3508 18	Y112	331 8506 00		
Y41	460 3508 20	Y113	331 8508 00	Y170	400 2505 07
Y42	460 3508 22	Y114	331 8510 00	Y171	400 2510 14
Y43	460 3508 24	Y115	331 8516 00		
Y44	460 3508 26	Y116	342 9100 00		
Y45	460 3510 16	Y117	330 3504 00		
Y46	460 5612 35	Y118	330 3506 00		
Y47	460 5612 45	Y119	330 3508 00		
Y48	460 3506 14	Y120	330 1212 00		
Y49	460 5060 08	Y121	330 3510 00		
Y50	460 5050 12	Y122	330 3520 00	Y180	404 6506 10
		Y123	330 1220 00	Y181	403 1560 16
		Y124	330 1205 00		
					Skt Hd Csk Screws

Ref	Part N ^o	Ref	Part N ^o	Ref	Part N ^o
	Cone Pt Skt Setscrews		Spring Washers		
Y186	403 5608 08	Y221	464 3020 00	Y260	353 3062 00
Y187	403 5608 10	Y222	464 3040 00	Y261	353 3071 60
Y188	403 5605 04	Y223	464 3050 00	Y262	353 3203 20
		Y224	464 3060 00	Y263	353 3204 25
		Y225	464 3070 00	Y264	353 3072 20
		Y226	464 3080 00	Y265	353 3062 00
		Y227	464 3100 00	Y266	353 3048 00
		Y228	464 3120 00		
		Y229	464 3160 00		
Y190	Cup Hd Bolts 461 5580 16	Y230	464 3620 00		
		Y231	464 3700 00		
		Y232	464 3660 00		
		Y233	464 3505 00		Wing Nuts
		Y234	464 3508 00	Y271	335 1506 00
	Flat Pt Skt Setscrews				
Y196	403 5740 40		Plain Washers		
Y197	403 5750 40	Y236	463 3020 00		
Y198	403 5760 10	Y237	463 3040 00		Fibre Washers
		Y238	463 3080 00	Y276	463 6040 00
		Y239	463 3100 00		
		Y240	463 3120 00		
Y206	Cup Pt Skt Setscrews 403 7508 12	Y241	463 3160 00		
Y207	403 7510 12	Y242	463 3200 00		
		Y243	463 3240 00		
		Y244	463 3312 00		Slotted Nuts
		Y246	463 3060 00	Y286	330 7506 00
Y211	C'sk Hd Bolts 400 2510 14		Taper Washers	Y290	407 2705 45
		Y250	465 2060 00	Y291	407 2705 25
		Y251	465 2080 00		
		Y252	465 2100 00		
Y216	Studs 411 9060 05				
Y217	411 9060 28		Split Pins		
		Y256	353 3028 00		
		Y257	353 3038 00		
		Y258	353 3051 60		
		Y259	353 3061 60		

Winget

LIMITED
CONSTRUCTION EQUIPMENT DIVISION

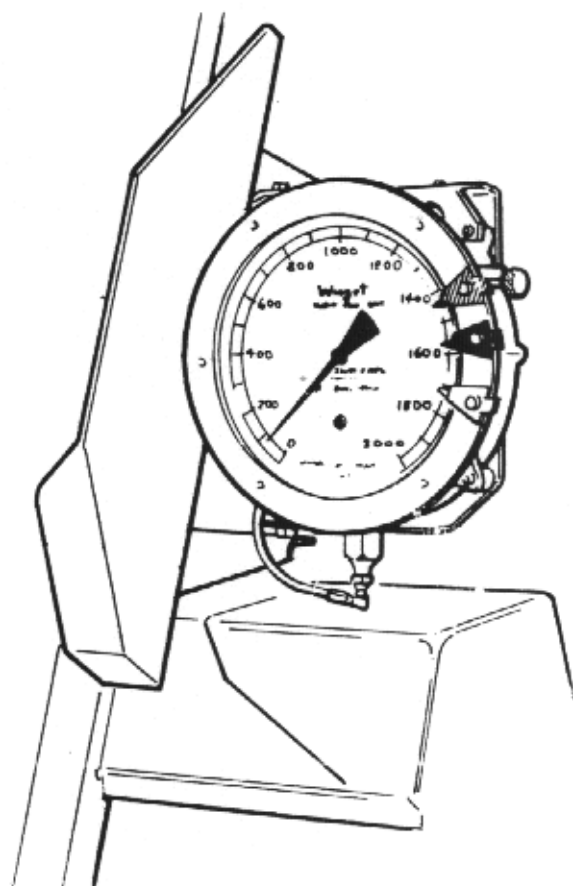

Loadcell
& Gauge

OPERATION MAINTENANCE
& SPARE PARTS MANUAL

LIST OF CONTENTS

<u>PAGE</u>	<u>DESCRIPTION AND OPERATING INSTRUCTIONS</u>
1	General
1	Weigh Gauge
1	Oscillation
2	Calibration
2	Loadcell Repair
2	Parting Loadcell by Press
3	Parting Loadcell by Lathe
3	Resealing Loadcell
3	Refilling Loadcell
3	Removing Air from Loadcell
3	Removing Air from Pipe
5	Gauge - Filling
5	Tube
5	Refitting

ILLUSTRATIONS

Gauge Adjustment	Fig. 1
Parting Loadcell by Press	Fig. 2
Parting Loadcell by Lathe	Fig. 3
Resealing Loadcell	Fig. 4
Refilling Loadcell	Fig. 5
Releasing Air from Loadcell	Fig. 6
Removing Air from Pipe	Fig. 7
Refilling Gauge	Fig. 8

GENERAL

The loadcell and gauge is a hydraulic method of recording pressure exerted on the loadcell button, by the batch in the weigh hopper.

The weigher gauge is mounted in a box on the side of the mixer and connected by a hydraulic pipe to the loadcell situated under the weigh hopper.

The gauge calibration differs to the mixer on which it is fitted, the adjustable coloured pointers mounted on the rim of the gauge can be set by the operator, to the aggregate proportions required. A protective lid is provided for the gauge box to prevent damage when not in use. The loadcells are of the 10 sq. in. (64.5 sq. cm.) type and a load/pressure ratio of 10:1. The loadcell and gauge is a closed circuit and any leakage from anywhere in the system will cause incorrect reading.

A screw is provided for zeroing the weigh gauge needle to take into account temperatures and variations in the weight of the hopper due to build-up of materials. Ensure that at all times there is a minimum of 2 in. or 50 mm. clearance between the hopper bottom and the ground.

WEIGH GAUGE

If by any chance a loaded hopper is dropped on to the loadcell by accident, causing undue shock to the gauge, this could loosen the pointer needle which is soldered on to its spindle. If this happens, remove the gauge from the loadcell pipe and release the front glass. Rotate the needle pointer gently to check if the solder connection has become loose. As shown in Fig. 1. If so, re-solder carefully. To ensure correct position for re-soldering pointer. Set the zeroing knob at a mid-position, and solder the pointer back from zero, the combined weight of cradle and hopper. Make sure that surplus solder does not run into the small bearing behind the needle pointer.

OSCILLATION

If the gauge needle pointer should oscillate unduly, first remove the back plate, by removing six Allen screws. For identification purposes, the only parts requiring adjustment for oscillation are painted blue. Loosen the blue locknut (1), as shown in Fig. 1, and turn the hexagon headed screw (2) below in a clockwise direction, until the pointer oscillation is

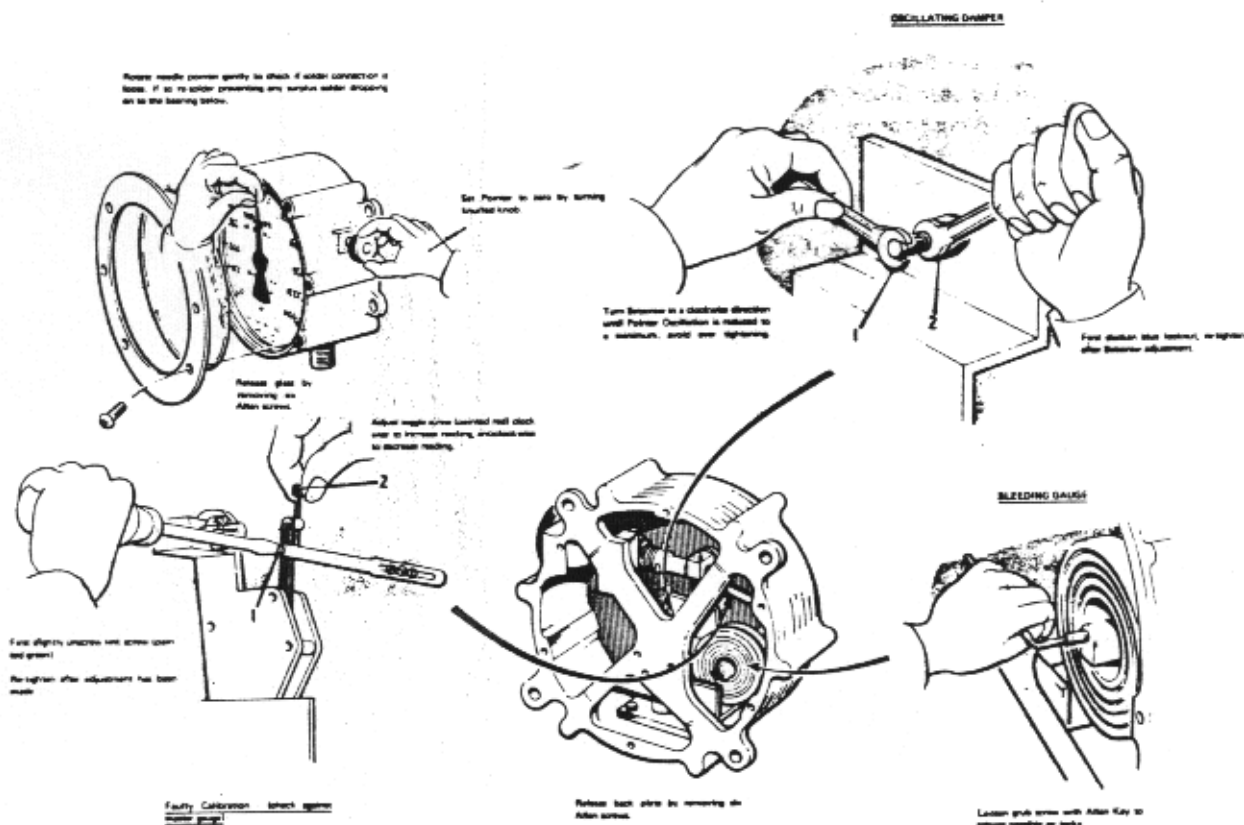

FIG. 1

GAUGE ADJUSTMENT

reduced to a minimum. At the same time avoid excessive tightening of the hexagon headed screw. A known weight should now be added to ensure that application of the damper has not affected weight reading. If the reading has been affected, this will indicate that the hexagon headed screw has been tightened down too far, so it should be released slightly until the reading becomes accurate. Remove the weights and check the pointer returns to zero. Re-tighten the blue locknut and refit back plate.

NOTE

The damper must not be applied too tightly, for this may cause movement wear and affect the calibration of the pointer.

CALIBRATION

If the calibration is found to be inaccurate, the pointer should be adjusted against a master gauge, as shown in Fig. 1. For identification purposes, the only parts requiring adjustment for calibration are painted red and green. First, slightly loosen link screw (1) painted green, then adjust knurled toggle screw (2) painted red, by hand. Turn clock-wise to accelerate the reading and anti-clockwise to decrease reading. This should be done on a gauge test rig or equivalent. After correct adjustment has been made, retighten link screw (1). Other screws must not be interfered with.

LOADCELL REPAIR

The loadcell itself can be made inoperative if a loaded hopper is dropped by accident on to it, or if aggregate were tipped from a dumper directly into the hopper. Both could cause the top half to turn over at an angle. This means that at least one "O" ring has been damaged. When this happens, the loadcell must be disconnected from the gauge and removed from the machine and the damaged rings replaced. There are two methods used for opening the loadcell. Firstly, by a press. Block up the loadcell on the base of the press using packing under the floating sleeve, this is to ensure that the body will move downwards, thus breaking the seals when pressure is applied to the loadcell button. Secondly, the diameter of the floating sleeve can be turned down on a lathe so as to reduce the thickness to approx. .010 in. (.25 mm.) at which stage the rims of the floating sleeve may be broken away releasing the sealing rings and inner parts. Clean and check the condition of all parts. Renew sealing rings and re-assemble, clamp the body of the loadcell in the lathe and rotate at a slow speed. By using a steel bar gradually roll the rims of the floating sleeve, thus re-sealing the loadcell.

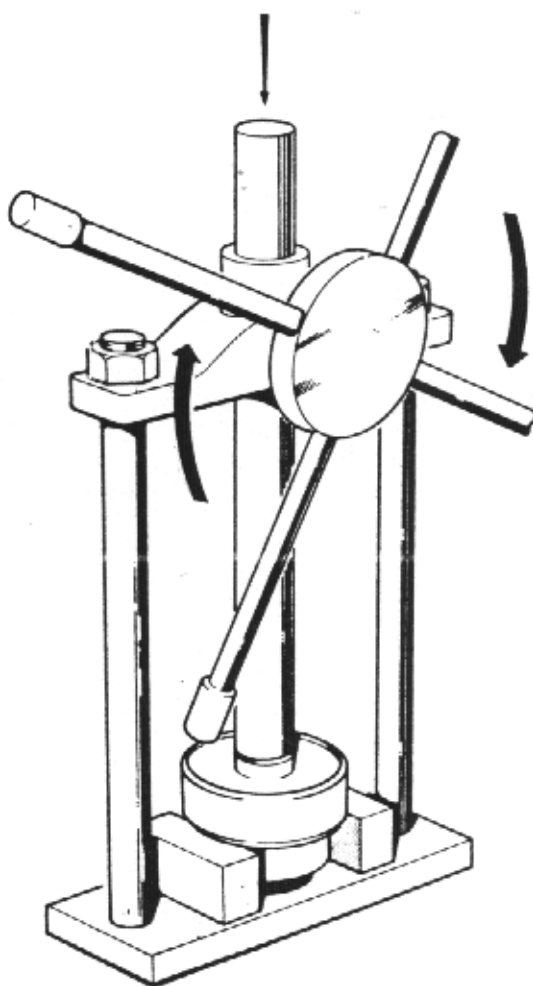

FIG. 2 PARTING LOADCELL BY PRESS

It is necessary when parting the Loadcell in the press, to ensure that the Floating Sleeve has been packed sufficiently to move downwards when pressure is applied to the Loadcell Button thus breaking the seals.

Alternatively the Floating Sleeve may be turned off in the lathe. First clamp the body of the Loadcell in the chuck and by taking light cuts, reduce the diameter by 0.100 ins. or 2.50 mm. At this stage it should be possible to split the outer skin releasing the inner parts.

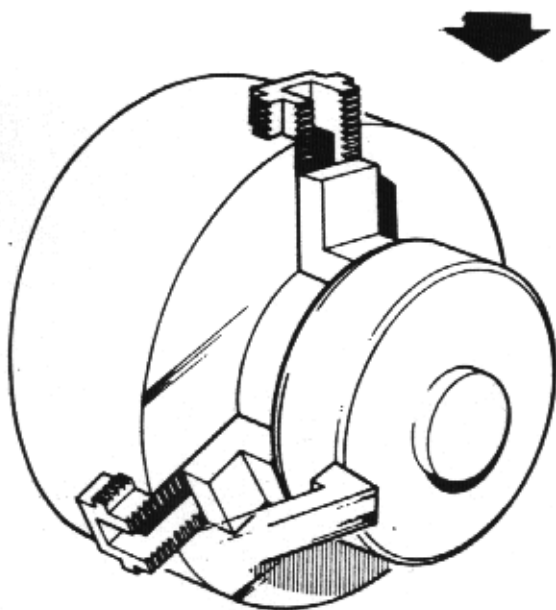

FIG. 3 PARTING LOADCELL BY LATHE

Resealing the loadcell—with all parts assembled in position apply a coating of Goodyear "Pliobond" around the outside edge of sealing rings. Now clamp the loadcell body in the chuck and gradually roll both edges of the floating sleeve thus locking the inner parts in position.

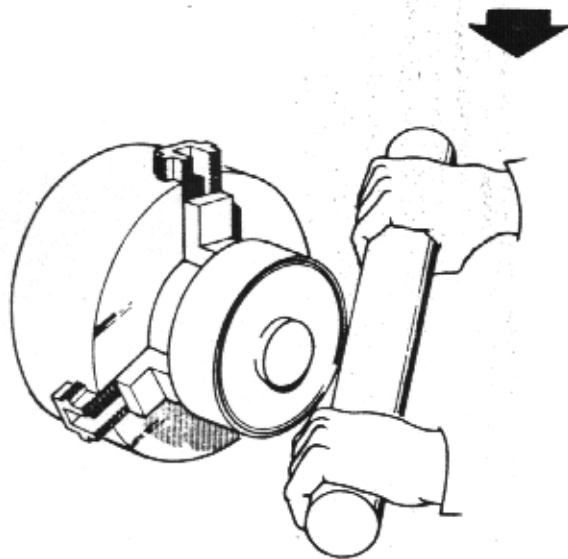

FIG. 4 RESEALING LOADCELL

REFILLING LOADCELL

The most efficient way of filling a loadcell and gauge, is by using a vacuum pump unit. This is normal practice. However, where this special equipment is not available, the operation can in some instances be carried out by hand. If care is taken, and the following procedure adopted: Place the loadcell in the vice with the button on one jaw, and the inlet for oil upwards, fill the loadcell with Wakefield Girling Brake and Clutch Fluid (crimson) and at the same time slightly compress the vice not more than $\frac{1}{16}$ in. or 1.60 mm., and let it return. Repeat this procedure several times. This will remove air bubbles. N.B. It must be remembered that when the loadcell is in use on the machine, the total amount of compression is less than $\frac{1}{16}$ in. or 1.6 mm. Therefore, when compressing this in the vice, it must be remembered to under no circumstances exceed $\frac{1}{16}$ in. or 1.6 mm., otherwise damage to the "O" ring seals may occur. It is advised before completely filling the loadcell to remove it from the vice, hold it in your hand with the button downwards, give a series of taps on the base of the loadcell with the other hand, as shown in Fig. 6 This will remove all remaining air locks. Replace the loadcell in the vice and compress a few more times. Continue filling to the point of overflow. Remove from the vice and place to one side with the oil filling end upwards.

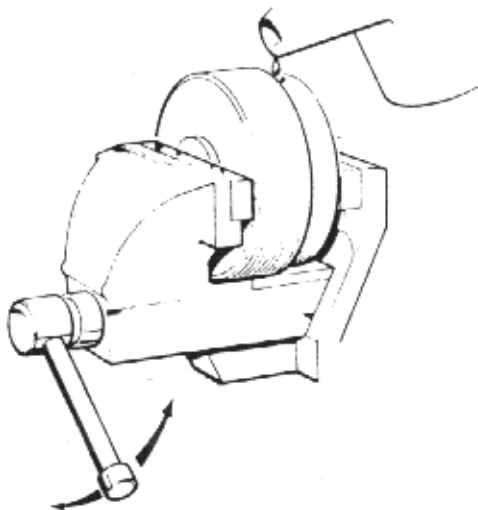

FIG. 5 REFILLING LOADCELL

Air bubbles may still be present in fluid. To remove secure Loadcell in vice with union hold upwards. Fill with oil. Move vice handle compressing Loadcell not more than $\frac{1}{16}$ " , then release. Repeat this process several times.

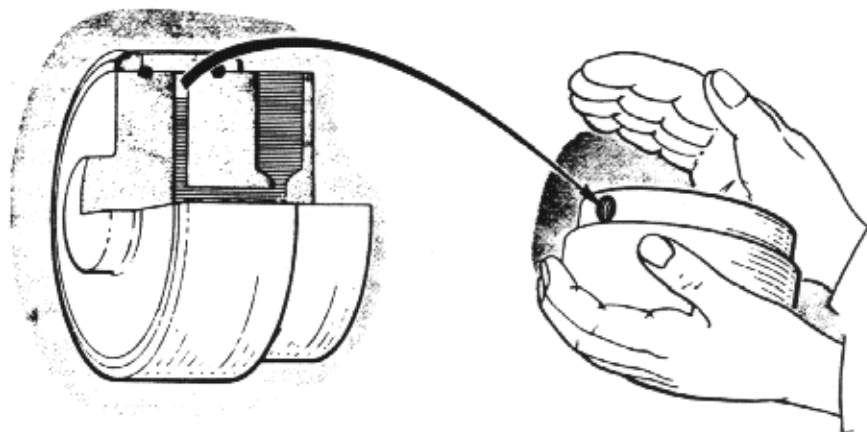

FIG. 6 RELEASING AIR FROM LOADCELL

During the Loadcell Filling Operation an air lock usually occurs in the fluid chamber. This will cause inaccurate weigh dial readings if allowed to remain.

To release Air Lock place Loadcell in hand and give a series of light taps with the other hand.

Replace Union and Pipe

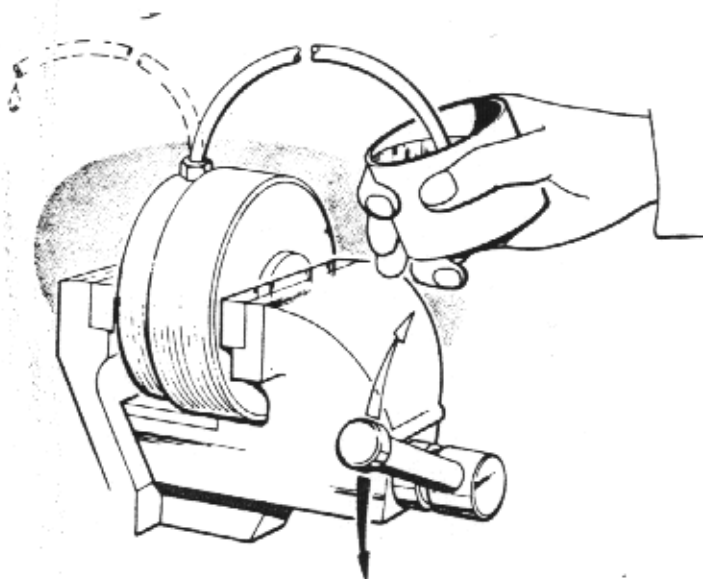

FIG. 7 REMOVING AIR FROM PIPE

Once again it is important to remove all air from pipe. Screw the vice up until fluid protrudes from end of pipe. Placing the pipe end in an improvised cup filled with fluid, release pressure on Loadcell

and the fluid will be drawn up the tube. Ensure that the tube is kept upright until fitted to gauge, so that fluid will not run out.

GAUGE

Due to a vacuum the gauge will invariably hold its quota of oil, but in any case, lay the gauge on its face and fix a right-angle adaptor to the oil inlet and fill with Wakefield Girling Brake and Clutch Fluid (crimson), shown in Fig. 8 open the bleed screw situated on the middle coil of the Bowden tube shown in Fig. 1. The weight of the fluid will expel any trace of air. Care should be taken to avoid oil dripping onto the back of the dial face. Ensure that the bleed screw is correctly tightened.

TUBE

The tube requires more careful attention to make sure that all air is extruded from the tube when being filled with oil. One method of dealing with this is to first screw the end of the tube to the loadcell, again holding the loadcell in the vice as shown in Fig. 7 Screw the vice up until oil reaches

the top of the tube. Place the pipe end in an improvised cup filled with fluid. Release pressure on the loadcell and the fluid will be drawn up the tube. Ensure that the tube is kept upright until fitted to gauge. Then join the top end of the tube to the gauge making sure that both unions on the gauge and tube are full of oil.

REFITTING

When the filling operation is complete, the gauge and loadcell may be refitted to the machine and tested with known weights, provided the adjusting screws in the gauge which control calibration have not been moved, the gauge should register correctly. A zeroing knob is provided on the side of the gauge, as shown in Fig. 1, this should be adjusted with the hopper empty and down on the loadcell. Check there is a clearance between the hopper and ground before zeroing.

Open Bleed Screw on middle coil of Bourbon Tube.
Re-tighten after air is expelled.

Care should be taken to avoid oil dripping onto back of dial face.

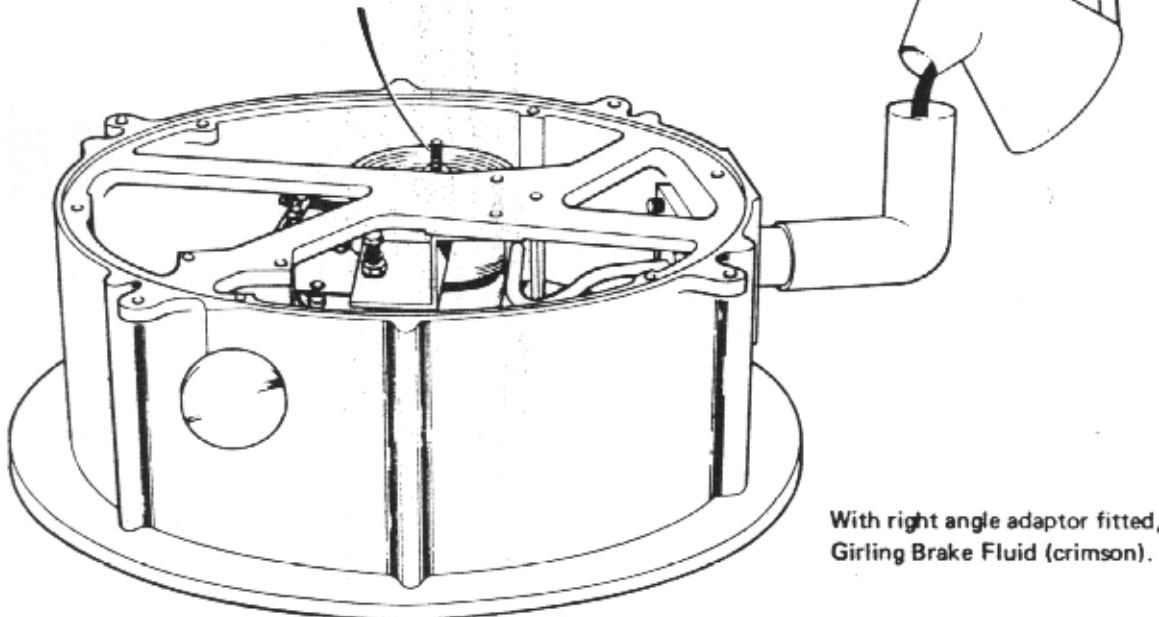

With right angle adaptor fitted, proceed to fill with Girling Brake Fluid (crimson).

FIG. 8 REFILLING GAUGE

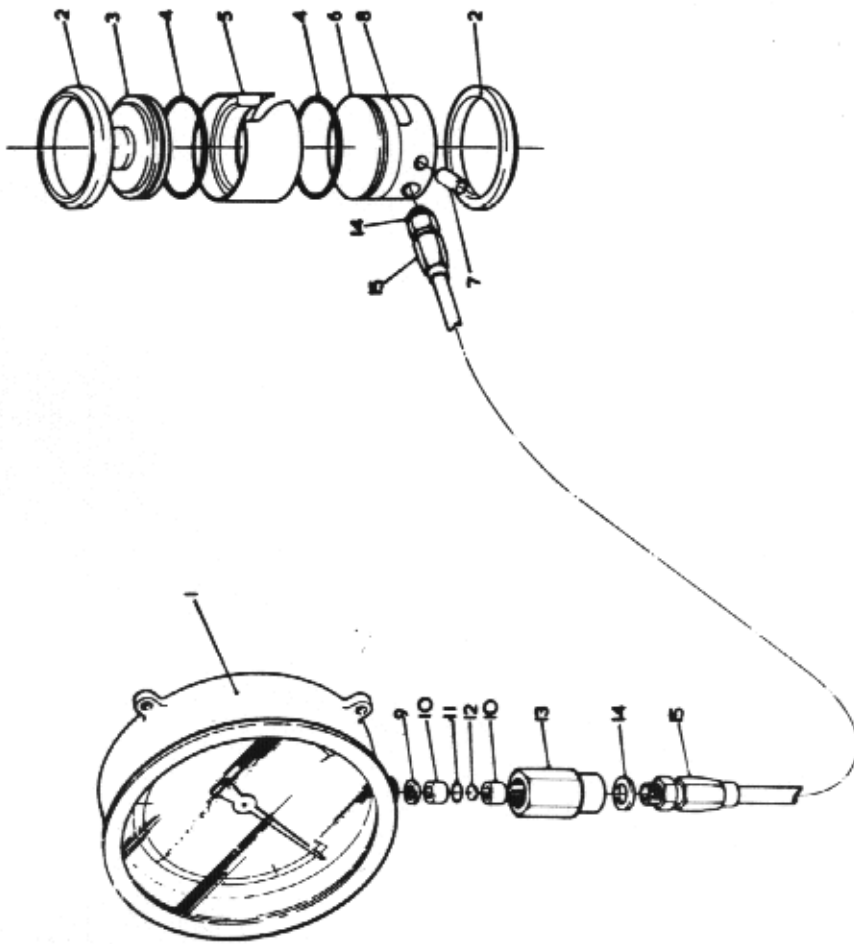

Ref	Description	Part No	Qty
1	Weighter Gauge 0-1,100 lbs.		1
2	Sealing Ring	513 2655 00	2
3	Platen	513 2654 00	1
4	10" Ring	417 8290 00	2
5	Floating Sleeve	513 2656 00	1
6	Loadcell Body	513 2653 00	1
	Complete with Screw	405 0120 25	1
	Spring washer	464 3512 00	1
7	Locking Pin	513 2657 00	1
8	Attachment of Loadcell	511 1372 00	1
9	Patent Plate	417 8580 00	1
10	Bonded Seal	503 1859 00	2
11	Collar	391 1070 00	1
12	10" Ring	503 1860 00	1
13	Restrictor	504 6811 00	1
14	Union Nut	417 8020 00	2
15	Bonded Seal	504 6813 00	1
	Loadcell Hose Assembly		

When Ordering
Always Quote :-

Machine N°, Part N°, Description and Quantity

Cyclopac

AIR CLEANER SERVICE PARTS

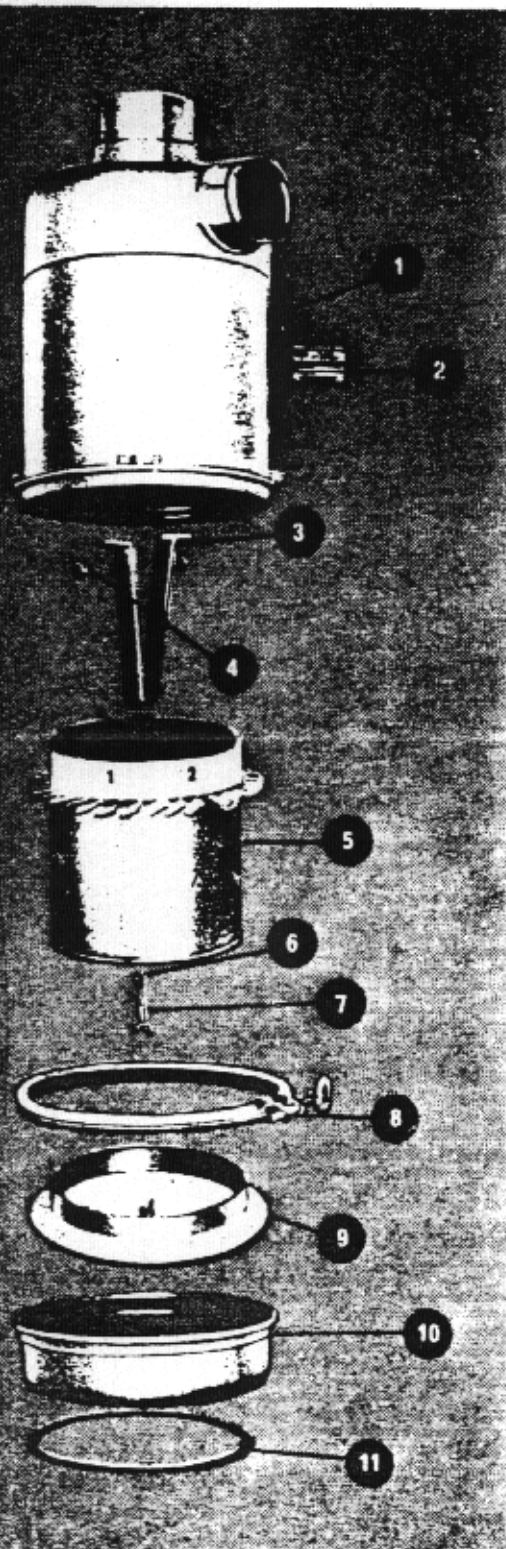

FWA

	DA 128	DA 127	DA 129	DA 131	DA 141			
1 Body Assy.	DU 807	DU 798	DU 817	DU 898	DU 1236			
2 Instruction Transfer	DU 669A	DU 669A	DU 669A	DU 669A	DU 669A			
3 Yoke	*	*	*	*	*			
4 Lockwasher Screw	*	*	*	*	*			
5 Element Assy.	DU 664	DU 750	DU 770	DU 879	DU 1233			
6 Gasket Washer	DU 658	DU 658	DU 658	DU 760	DU 260			
7 Wing Nut	DU 657	DU 657	DU 657	DU 257	DU 257			
8 Clamp Assy.	DU 665	DU 749	DU 420	DU 882	DU 481			
9 Baffle	DU 641	DU 747	DU 766	DU 880	DU 1207			
10 Cup Assy.	DU 666	DU 748	DU 769	DU 881	DU 1208			
11 Cup Gasket	None	None	None	DU 876	DU 314			

* Not a Service Part.

FWG

	DA 121	DA 122	DA 123	DA 130	DA 140	DA 150	
1 Body Assy.	DU 667	DU 753	DU 773	DU 877	DU 1205	DU 1517	
2 Instruction Transfer	DU 669A	DU 669A	DU 669A	DU 669A	DU 669A	DU 669A	
3 Yoke	*	*	*	*	*	*	
4 Lockwasher Screw	*	*	*	*	*	*	
5 Element Assy.	DU 664	DU 750	DU 770	DU 879	DU 1206	DU 1518	
6 Gasket Washer	DU 658	DU 658	DU 658	DU 260	DU 658	DU 658	
7 Wing Nut	DU 657	DU 657	DU 657	DU 257	DU 657	DU 657	
8 Clamp Assy.	DU 665	DU 749	DU 420	DU 882	DU 481	DU 977	
9 Baffle	DU 641	DU 747	DU 766	DU 880	DU 1207	DU 1519	
10 Cup Assy.	DU 666	DU 748	DU 769	DU 881	DU 1208	DU 1520	
11 Cup Gasket	None	None	None	DU 876	DU 314	DU 223	

* Not Service Part.

SPECIFICATIONS

Cyclopac FW Series

AIR CLEANERS

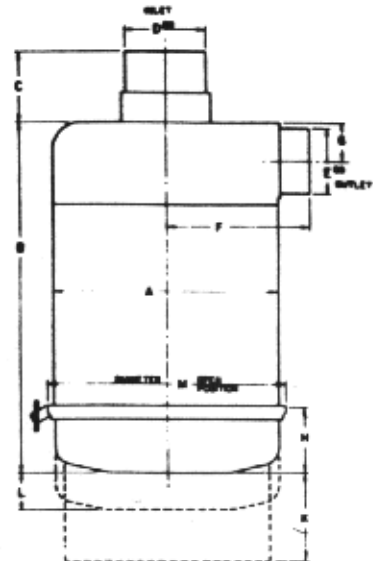

FWA and FWG cleaners can be mounted either horizontally or vertically.

FWA

Air Cleaner Model	* Air Flow Rating		A	B	C	D	E	F	G	H	K	L	M	Approx. Wt. Lbs.
	At 8" H ₂ O													
DA 128	80		5½	14¾	1½	2	2	4	1½	3½	8½	1½	6½	6
DA 127	110		6½	17¾	2½	2½	2½	4½	1¾	3½	8½	1½	7½	8
DA 129	190		8	18¾	2½	3	3	6½	2½	3½	9½	1½	8½	10½
DA 131	290		10½	18½	3½	3½	4	7½	2½	4	7½	1½	11½	20
DA 141	385		11½	19½	3½	4½	4	7½	2½	4	7½	1½	13½	28

*Ratings are ± 1" H₂O

FWG

Air Cleaner Model	* Air Flow Rating		A	B	C	D	E	F	G	H	K	L	M	Approx. Wt. Lbs.
	At 8" H ₂ O													
DA 121	95		5½	12¾	1½	2	2	4	1½	3½	8½	1½	6½	4½
DA 122	140		6½	13¾	1½	2½	2½	4½	1½	3½	8½	1½	7½	6½
DA 123	250		8	14¾	1½	3	3	6½	1½	3½	9½	1½	8½	9½
DA 130	330		10½	16¾	1½	4	4	7½	2½	4	7½	1½	11½	17
DA 140	450		11½	17¾	3½	5	5	8½	4½	4	10½	1½	13½	29
DA 150	730		14	21½	2½	6	6	10½	5½	4	13½	1	15½	40½

*Ratings are ± 1" H₂O

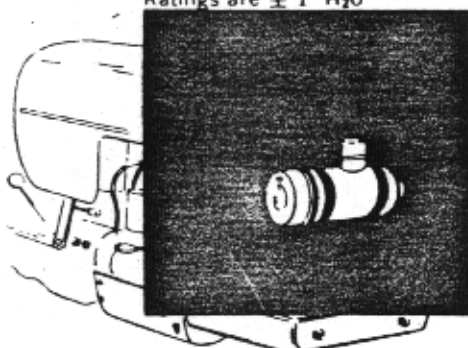

FWG CYCLOPAC installed horizontally on farm tractor.



COOPER-KLEEN FILTER CLEANER

Detergent with carbon dissolving additive. Mix with water. Cleans any washable paper filter.

RESTRICTION INDICATOR

Signal locks in view when filter element requires servicing. Mount on dash or cleaner ducting. (See separate leaflet.)

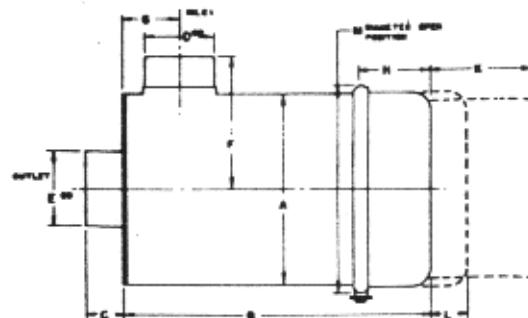

CALIFORNIA

Proposition 65 Warning

Diesel engine exhaust and some of its constituents are known to the State of California to cause cancer, birth defects, and other reproductive harm